

Network converter

MECHATROLINK-II compatible

NETC01-M2

USER MANUAL

Thank you for purchasing an Oriental Motor product.
This Manual describes product handling procedures and safety precautions.



- Please read it thoroughly to ensure safe operation.
- Always keep the manual where it is readily available.

Table of contents

1	Safety precautions	3	9	Details of command	20
2	Introduction	4	9-1	No operation command (NOP: 00h)	20
3	Preparation	6	9-2	Read ID command (ID_RD: 03h)	22
3-1	Checking the product	6	9-3	Read alarm or warning command (ALM_RD: 05h)	24
3-2	Names and functions of parts	6	9-4	Clear alarm or warning command (ALM_CLR: 06h)	24
4	Installation	8	9-5	Establish connection command (CONNECT: 0Eh)	25
4-1	Location for installation	8	9-6	Release connection command (DISCONNECT: 0Fh)	26
4-2	Installation method	8	9-7	Data READ/WRITE_A command (DATA_RWA: 50h)	27
4-3	Installing and wiring in compliance with EMC Directive	9	9-8	Timing chart of the data READ/ WRITE_A command	32
5	Connection	11	10	Troubleshooting and remedial actions	39
5-1	Connection example	11	10-1	Alarms and MECHATROLINK-II communication error	39
5-2	Connecting the power supply and grounding the NETC01-M2	11	10-2	Warning	42
5-3	Connecting the RS-485 communication cable	12	11	Inspection	43
5-4	Connecting the MECHATROLINK-II communication	13	12	General specifications	44
5-5	Connecting the data setter	13	13	Operation using the OPX-2A	45
6	Guidance	14	13-1	Overview of the OPX-2A	45
7	Setting	17	13-2	Names and functions of parts	46
7-1	Transmission rate of RS-485 communication	17	13-3	Notation	46
7-2	Operation mode	17	13-4	How to read the display	46
7-3	Station address	18	13-5	OPX-2A error display	47
8	MECHATROLINK-II communication format	19	13-6	Screen transitions	48
8-1	Data format	19	13-7	Monitor mode	50
8-2	Phase	19	13-8	Parameter mode	51
			13-9	Copy mode	52
			14	Accessories	54

1 Safety precautions

The precautions described below are intended to prevent danger or injury to the user and other personnel through safe, correct use of the product. Use the product only after carefully reading and fully understanding these instructions.

 WARNING	 CAUTION
<p>Handling the product without observing the instructions that accompany a "WARNING" symbol may result in serious injury or death.</p> <p>General</p> <ul style="list-style-type: none"> Do not use the product in explosive or corrosive environments, in the presence of flammable gases, locations subjected to splashing water, or near combustibles. Doing so may result in fire or injury. Assign qualified personnel to the task of installing, wiring, operating/controlling, inspecting and troubleshooting the product. Failure to do so may result in fire, injury or damage to equipment. <p>Connection</p> <ul style="list-style-type: none"> Always keep the power supply voltage of the NETC01-M2 within the specified range. Failure to do so may result in fire. For the power supply of the NETC01-M2, use a DC power supply with reinforced insulation on its primary and secondary sides. Failure to do so may result in electric shock. Connect the cables securely according to the wiring diagram. Failure to do so may result in fire. Do not forcibly bend, pull, or pinch the cable. Doing so may result in fire. Do not apply stress to the connection area of the power cable. Doing so may result in damage to the product. <p>Operation</p> <ul style="list-style-type: none"> Turn off the NETC01-M2 power supply in the event of a power failure. Otherwise, the motor may suddenly start when the power is restored, causing injury or damage to equipment. <p>Repair, disassembly and modification</p> <ul style="list-style-type: none"> Do not disassemble or modify the NETC01-M2. Doing so may result in injury or damage to equipment. Refer all such internal inspections and repairs to the Oriental Motor sales office from which you purchased the product. 	<p>Handling the product without observing the instructions that accompany a "CAUTION" symbol may result in injury or property damage.</p> <p>General</p> <ul style="list-style-type: none"> Do not use the NETC01-M2 beyond its specifications. Doing so may result in injury or damage to equipment. Keep your fingers and objects out of the openings in the NETC01-M2. Failure to do so may result in fire or injury. <p>Installation</p> <ul style="list-style-type: none"> Install the NETC01-M2 inside an enclosure. Failure to do so may result in injury. Keep the area around the NETC01-M2 free of combustible materials. Failure to do so may result in fire or a skin burn(s). Do not leave anything around the NETC01-M2 that would obstruct ventilation. Doing so may result in damage to equipment. <p>Connection</p> <ul style="list-style-type: none"> The power supply connector (CN1), MECHATROLINK-II communication connectors (CN2-1, CN2-2), data edit connector (CN3) and RS-485 communication connector (CN6) of the NETC01-M2 are not electrically insulated. When grounding the positive terminal of the power supply, do not connect any equipment (PC, etc.) whose negative terminal is grounded. Doing so may result in the NETC01-M2 and these equipment to short, damaging both. <p>Operation</p> <ul style="list-style-type: none"> Use the NETC01-M2 in combination with the designated applicable product. Failure to do so may result in fire. When operating the product, do so after making preparations that an emergency stop can be performed at any time. Failure to do so may result in injury. Immediately when trouble has occurred, stop running and turn off the NETC01-M2 power. Failure to do so may result in fire or injury. Take measures against static electricity when operating the switches of the NETC01-M2. Failure to do so may result in malfunction of the NETC01-M2 or damage to equipment. <p>Disposal</p> <ul style="list-style-type: none"> Dispose the NETC01-M2 correctly in accordance with laws and regulations, or instructions of local governments.

2 Introduction

■ Before use

Only qualified personnel of electrical and mechanical engineering should work with the product. Use the product correctly after thoroughly reading the "1 Safety precautions" on p.3. In addition, be sure to observe the contents described in warning, caution, and note in this manual. The product described in this manual has been designed and manufactured for use in general industrial equipment. Do not use for any other purpose. For the power supply of the **NETC01-M2**, use a DC power supply with reinforced insulation on its primary and secondary sides. Oriental Motor Co., Ltd. is not responsible for any damage caused through failure to observe this warning.

■ Related operating manuals

For operating manuals not included with the product, contact your nearest Oriental Motor sales office or download from Oriental Motor Website Download Page.

Name	Included or not included with product
Network converter MECHATROLINK-II compatible NETC01-M2 USER MANUAL (this document)	Not included

■ Notation on operating manual

	The items under this heading contain important handling instructions that the user should observe to ensure the safe use of the product.
--	--

■ Overview of the product

The **NETC01-M2** is a communication converter between MECHATROLINK-II and RS-485 communication. By converting the MECHATROLINK-II communication protocol of the upper level to the RS-485 communication protocol of the lower level, Oriental Motor RS-485 communication compatible products can be operated via MECHATROLINK-II communication.

The RS-485 communication protocol of the lower level is Oriental Motor's own RS-485 communication protocol.

**Parameters of the NETC01-M2 cannot be set with the master station.
When setting the parameters of the NETC01-M2, use a support software
MEXE02 or accessory data setter OPX-2A.**

When the **MEXE02** is used, a communication cable for support software **CC05IF-USB** (accessory) is needed to connect a PC and **NETC01-M2**. Be sure to purchase it.

■ System configuration

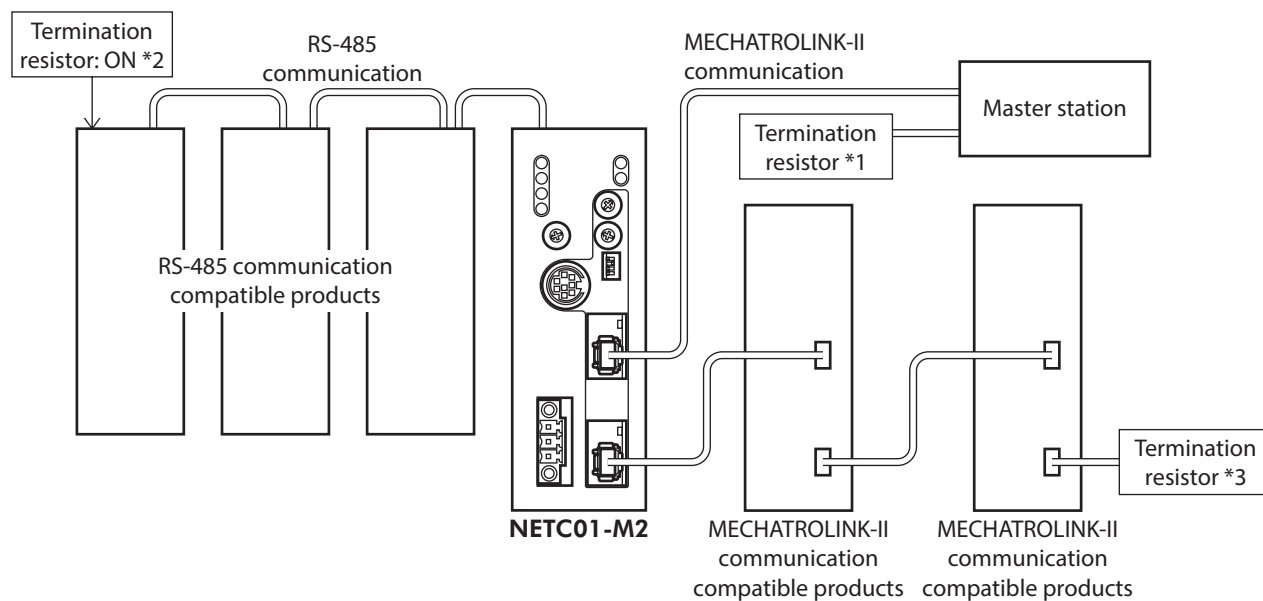

- *1 The master device may have a built-in internal termination resistor which functions as the termination resistor on the master side. For details, refer to the operating manual for the master device.
- *2 The termination resistor for RS-485 communication is built into the product.
- *3 For the termination resistor on device side, use a dedicated termination resistor for MECHATROLINK communication, manufactured by YASKAWA Electric Corporation.

■ CE Marking

This product is affixed with the marks under the following directive.

- **EMC Directive**

Refer to "4-3 Installing and wiring in compliance with EMC Directive" on p.9 for details about conformity.

- **RoHS Directive**

This product does not contain the substances exceeding the restriction values.

3 Preparation

This chapter explains the items you should check, as well as the name and function of each part.

3-1 Checking the product

Verify that the items listed below are included. Report any missing or damaged items to the Oriental Motor sales office from which you purchased the product.

- **NETC01-M2**.....1 unit
- CN1 connector (3 pins).....1 pc.
- RS-485 communication cable2 pcs. [0.1 m (3.94 in.), 0.25 m (9.84 in.) each 1 pc.]
- Instructions and Precautions for Safe Use.....1 copy

3-2 Names and functions of parts

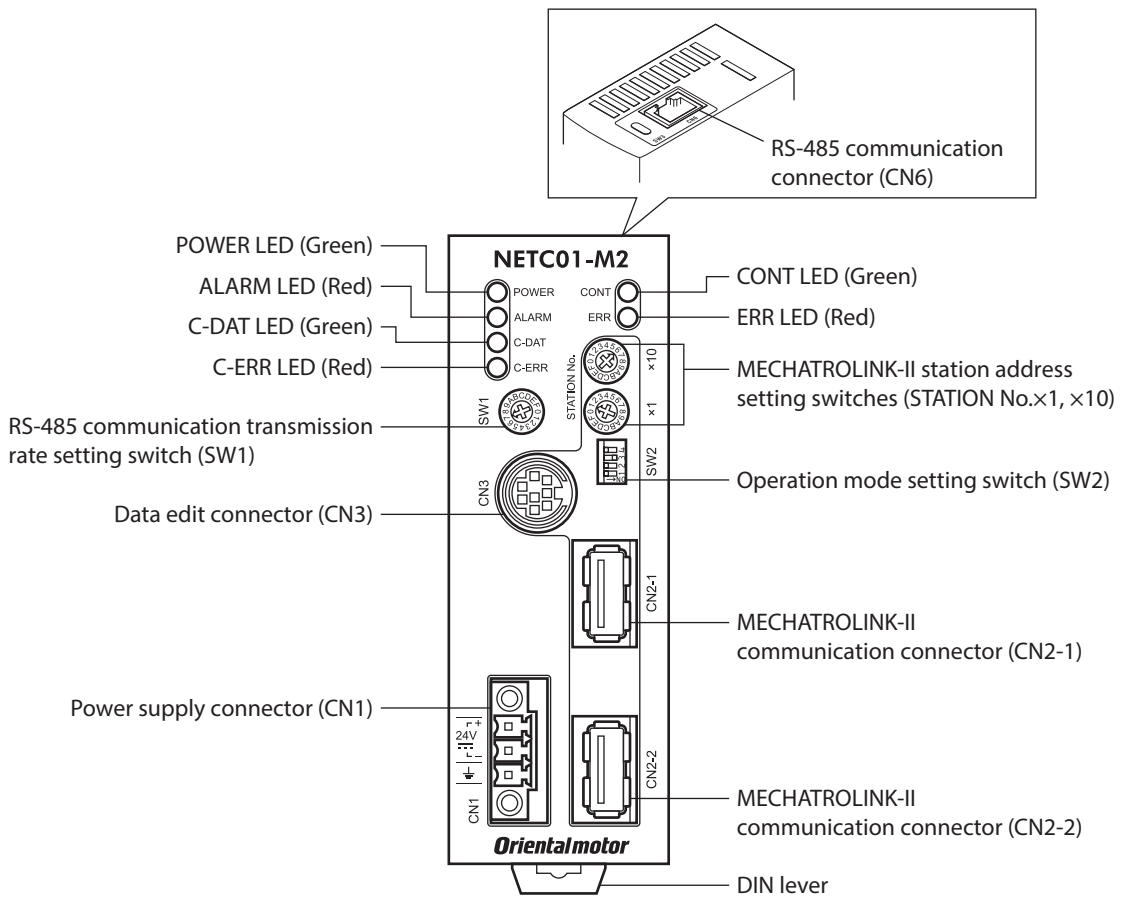

Name	Description	Ref.
POWER LED (Green)	This LED is lit while the power is input.	–
ALARM LED (Red)	This LED will blink when an alarm generates.	p.39
C-DAT LED (Green)	This LED is lit while transmitting and receiving data via RS-485 communication.	–
C-ERR LED (Red)	This LED is lit when an error has occurred via RS-485 communication.	–
CONT LED (Green)	This LED is lit while a connection is established.	–
ERR LED (Red)	This LED is lit when the MECHATROLINK-II communication error has occurred.	p.39
RS-485 communication transmission rate setting switch (SW1)	Sets the transmission rate of RS-485 communication. Factory setting: 7 (625 kbps)	p.17
Data edit connector (CN3)	Connects a PC in which the MEXE02 has been installed, or an accessory OPX-2A .	p.13
Power supply connector (CN1)	Connects a 24 VDC power supply.	p.11
MECHATROLINK-II station address setting switches (STATION No.×1, ×10)	Set the station address in the 60h to 7Fh range. Factory setting: 61h (×10=6, ×1=1) ×10: Sets the upper of the station address. ×1: Sets the lower of the station address.	p.18
Operation mode setting switch (SW2-Nos.1 to 3)	Sets the operation mode. <ul style="list-style-type: none"> • SW2-No.1: Sets the remote I/O occupied size. Factory setting: OFF (16 bit mode) • SW2-No.2, No.3: Set the number of transmission bytes. Factory setting: No.2=OFF, No.3=ON (32 bytes) 	p.17
MECHATROLINK-II communication connectors (CN2-1, CN2-2)	Connect the MECHATROLINK-II communication cable.	p.13
RS-485 communication connector (CN6)	Connects the RS-485 communication cable.	p.12

4 Installation

This chapter explains the installation location and installation methods of the **NETC01-M2**. The installation and wiring methods in compliance with the EMC Directive are also explained.

4-1 Location for installation

The **NETC01-M2** has been designed and manufactured for use as a component to be installed inside equipment. Install it in a well-ventilated location that provides easy access for inspection. The location must also satisfy the following conditions:

- Inside an enclosure that is installed indoors (provide vent holes)
- Operating ambient temperature 0 to +40 °C (+32 to +104 °F) (non-freezing)
- Operating ambient humidity 85 % or less (non-condensing)
- Area that is free of explosive atmosphere or toxic gas (such as sulfuric gas) or liquid
- Area not exposed to direct sun
- Area free of excessive amount of dust, iron particles or the like
- Area not subject to splashing water (rain, water droplets), oil (oil droplets) or other liquids
- Area free of excessive salt
- Area not subject to continuous vibration or excessive shocks
- Area free of excessive electromagnetic noise (from welders, power machinery, etc.)
- Area free of radioactive materials, magnetic fields or vacuum

4-2 Installation method

Install the **NETC01-M2** to a 35 mm (1.38 in.) width DIN rail. There must be a clearance of at least 50 mm (1.97 in.) in the horizontal and vertical directions, between the **NETC01-M2** and enclosure or other equipment within the enclosure. When installing two or more **NETC01-M2** in parallel, it is possible to install them closely in the horizontal direction. Provide a minimum clearance of 50 mm (1.97 in.) in the vertical direction.

Note Be sure to install the **NETC01-M2** vertically (vertical position). If the **NETC01-M2** is installed in the direction other than vertical position, its heat radiation effect will deteriorate.

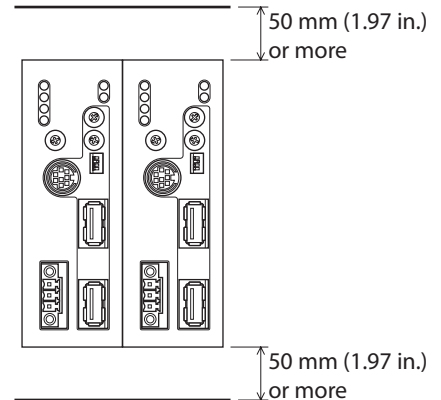

■ Mounting to DIN rail

Pull down the DIN lever of the **NETC01-M2** and lock it. Hang the hook at the rear to the DIN rail, and push in the **NETC01-M2**. After installation, secure the both sides of the **NETC01-M2** with the end plate.

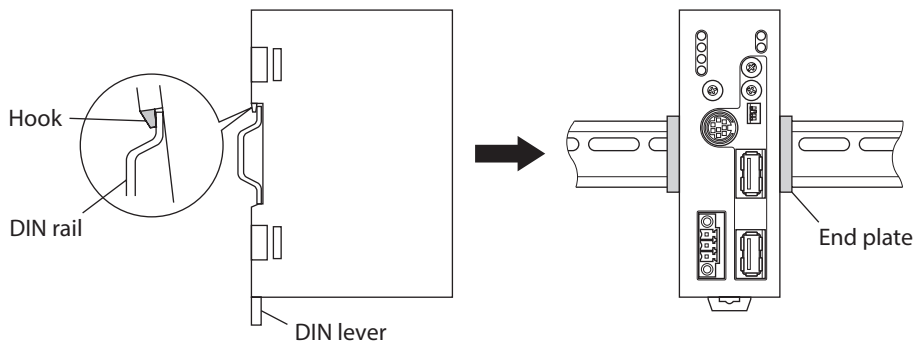

Removing from DIN rail

Pull the DIN lever down until it locks using a slotted screwdriver, and lift the bottom of the **NETC01-M2** to remove it from the rail.

Use force of about 10 to 20 N (2.2 to 4.5 lb.) to pull the DIN lever to lock it. Excessive force may damage the DIN lever.

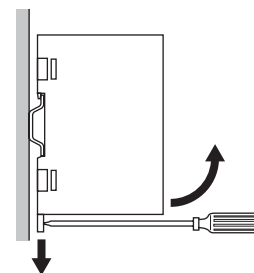

4-3 Installing and wiring in compliance with EMC Directive

Effective measures must be taken against the EMI that the **NETC01-M2** may give to adjacent control-system equipment, as well as the EMS of the **NETC01-M2** itself, in order to prevent a serious functional impediment in the machinery. The use of the following installation and wiring methods will enable the **NETC01-M2** to be compliant with the EMC Directive.

Oriental Motor conducts EMC measurements on its **NETC01-M2** in accordance with "Example of **NETC01-M2** installation and wiring" on p.10. The user is responsible for ensuring the machine's compliance with the EMC Directive, based on the installation and wiring explained below.

⚠ CAUTION

This equipment is not intended for use in residential environments nor for use on a low-voltage public network supplied in residential premises, and it may not provide adequate protection to radio reception interference in such environments.

■ Power supply

This network converter is a product of DC power supply input.

Use a DC power supply (switching power supply etc.) that conforms to the EMC Directive.

■ Noise filter

- Connect a noise filter in the DC power supply input to prevent the noise generated in the **NETC01-M2** from propagating externally through the power supply line.
- When using a power supply transformer, be sure to connect a noise filter to the AC input side of the power supply transformer.
- For a noise filter, use HF2010A-UPF (SOSHIN ELECTRIC CO., LTD.), FN2070-10-06 (Schaffner EMC) or equivalent product.
- Install the noise filter as close to the AC input terminal of DC power supply as possible. Use cable clamps and other means to secure the AC input cables (AWG18: 0.75 mm² or more) and output cables (AWG18: 0.75 mm² or more) firmly to the surface of the enclosure.
- Connect the ground terminal of the noise filter to the grounding point, using as thick and short a wire as possible.
- Do not place the AC input cable parallel with the noise filter output cable. Parallel placement will reduce noise filter effectiveness if the enclosure's internal noise is directly coupled to the power supply cable by means of stray capacitance.

■ How to ground

The cable used to ground the **NETC01-M2** and mains filter must be as thick and short as possible so that no potential difference is generated. Choose a large, thick and uniformly conductive surface for the grounding point.

■ Wiring the power supply cable and I/O signal cable

- Use a shielded cable of AWG22 (0.3 mm²) or more for the power supply cable of the **NETC01-M2**, and keep it as short as possible.
- For the MECHATROLINK-II communication cable, use a dedicated cable with connector.
- To ground the power supply cable, use a metal cable clamp or similar device that will maintain contact with the entire circumference of the cable. Attach a cable clamp as close to the end of the cable as possible, and connect it as shown in the figure.

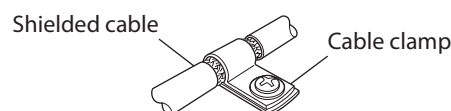

■ **Notes about installation and wiring**

- Connect the **NETC01-M2** and other peripheral control equipment directly to the grounding point so as to prevent a potential difference from developing between grounds.
- When relays or electromagnetic switches are used together with the system, use noise filters and CR circuits to suppress surges generated by them.
- Keep cables as short as possible without coiling and bundling extra lengths.
- Place the power cables such as the motor and power supply cables as far as 100 mm (3.94 in.) from the signal cables. If the power cables and signal cables have to cross, cross them at a right angle. Place the AC input cable and output cable of a noise filter separately from each other.

■ **Example of NETC01-M2 installation and wiring**

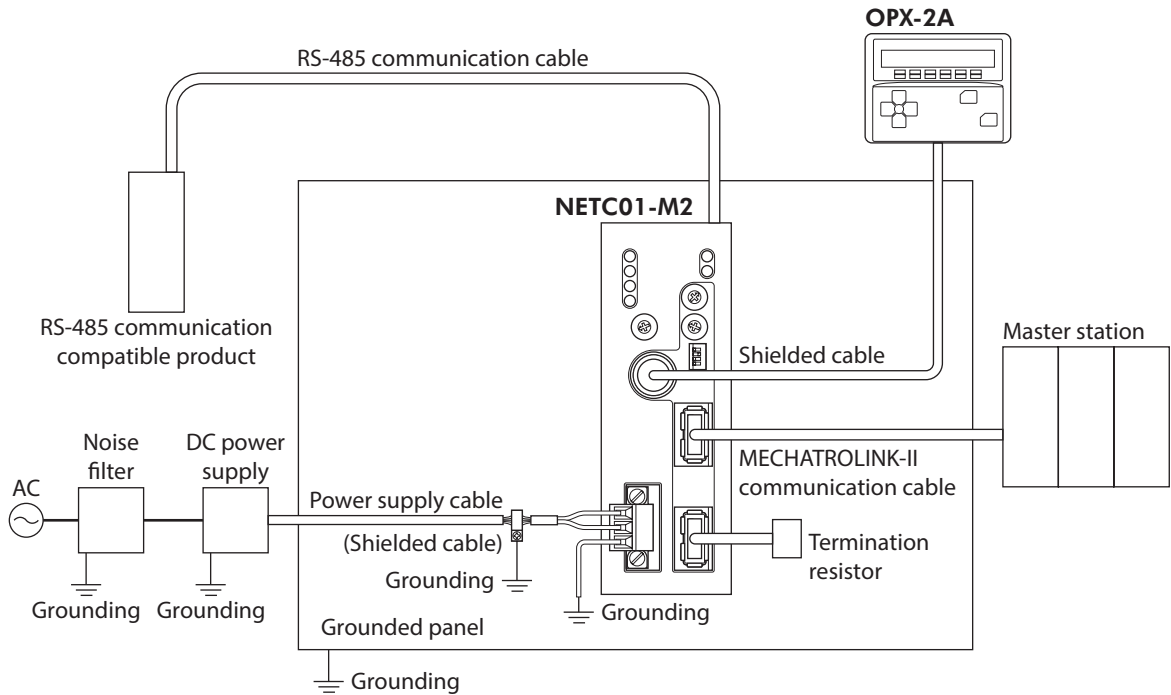

■ **Precautions about static electricity**

Static electricity may cause the **NETC01-M2** to malfunction or suffer damage. While the **NETC01-M2** is receiving power, handle the **NETC01-M2** with care and do not come near or touch the **NETC01-M2**. Always use an insulated screwdriver to change the switches of the **NETC01-M2**.

Note The **NETC01-M2** uses parts that are sensitive to electrostatic charge. Before touching the **NETC01-M2**, turn off the power to prevent electrostatic charge from generating. If an electrostatic charge is impressed on the **NETC01-M2**, the **NETC01-M2** may be damaged.

5 Connection

This chapter explains the connection method of the **NETC01-M2** and power supply/communication cable, as well as the grounding method.

⚠ WARNING For protection against electric shock, do not turn on the power supply until the wiring is completed.

5-1 Connection example

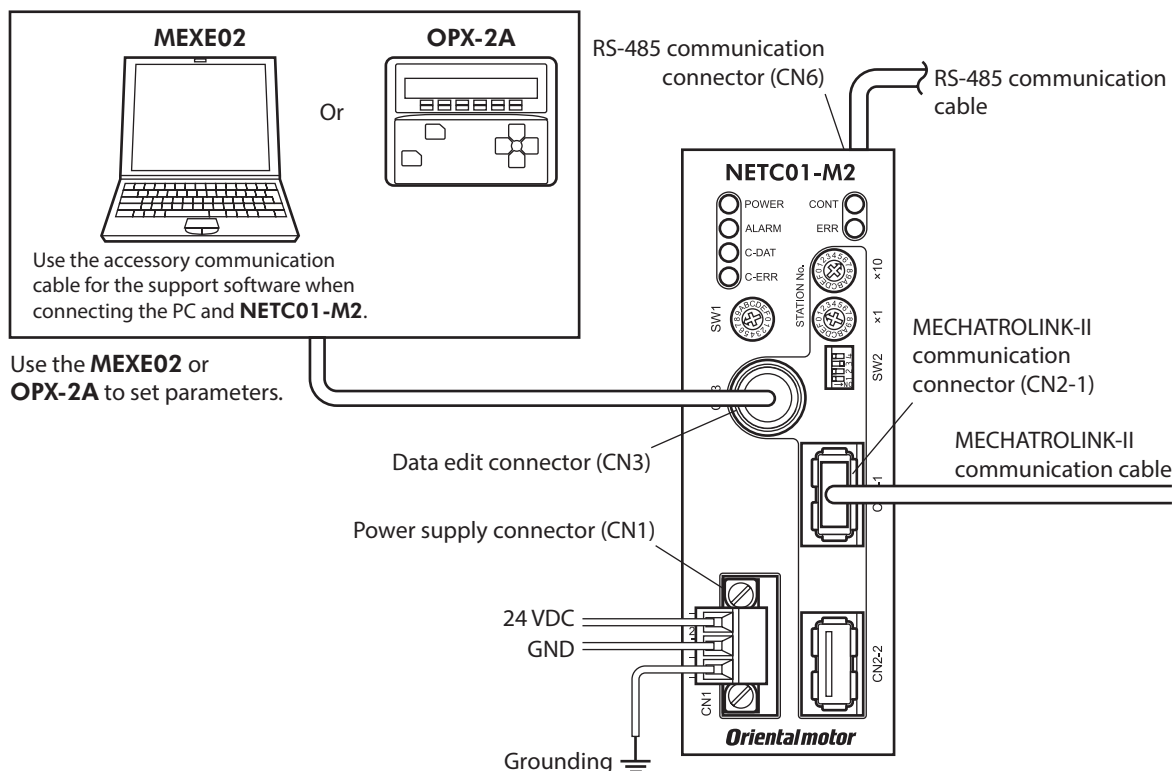

5-2 Connecting the power supply and grounding the NETC01-M2

■ Connecting the power supply

Connect the power supply cable (AWG22: 0.3 mm²) to the power supply connector (CN1) of the **NETC01-M2** using the included CN1 connector (3 pins).

■ Grounding the NETC01-M2

Ground the Frame Ground terminal (FG) of the **NETC01-M2** as necessary. Ground using a wire of AWG24 to 16 (0.2 to 1.25 mm²), and do not share the protective earth terminal with a welder or any other power equipment.

■ CN1 connector pin assignments

Pin No.	Signal name	Description
1	+24 VDC	+24 VDC 0.2 A or more
2	GND	Power supply GND
3	FG	Frame Ground

Note

- When connecting, pay attention to the polarity of the power supply. Reverse-polarity connection may cause damage to the **NETC01-M2**.
- Do not wire the power supply cable of the **NETC01-M2** in the same cable duct with other power lines. Doing so may cause malfunction due to noise.

■ Connecting method

1. Strip the insulation cover of the lead wire by 7 mm (0.28 in.)

2. Insert each lead wire into the CN1 connector and tighten the screw using a slotted screwdriver.
Connector screw size: M2
Tightening torque: 0.22 to 0.25 N·m (31 to 35 oz-in)

3. Insert the CN1 connector into the CN1 and tighten the screws using a slotted screwdriver.
Connector screw size: M2.5
Tightening torque: 0.4 N·m (56 oz-in)

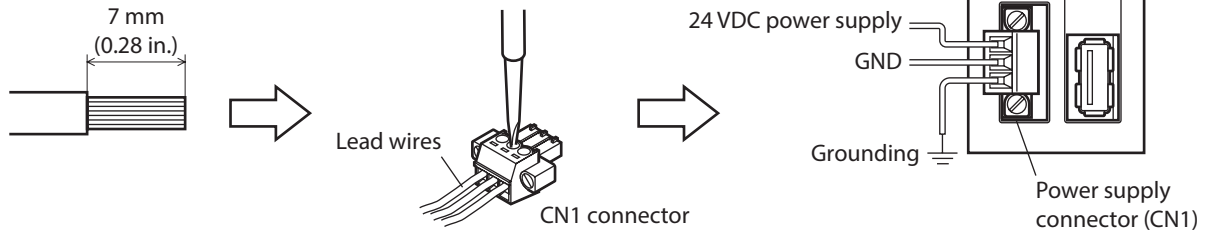

5-3 Connecting the RS-485 communication cable

Connect the **NETC01-M2** and RS-485 communication compatible product using the included RS-485 communication cable.

Connect the RS-485 communication cable to RS-485 communication connector (CN6). Since RS-485 communication cables of two lengths are included, use either one of the two.

You can also use a commercial LAN cable (straight cable) to link drivers.

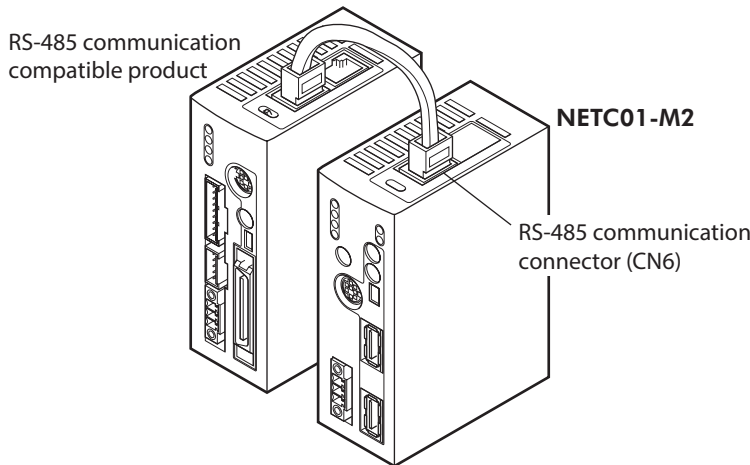

■ CN6 connector pin assignments

Pin No.	Signal name	Description
1	N.C.	Not used (Do not connect anything.)
2	GND	GND
3	TR+	RS-485 communication signal (+)
4	N.C.	Not used
5		
6	TR-	RS-485 communication signal (-)
7	N.C.	Not used
8		

• NETC01-M2 internal circuit and termination resistor

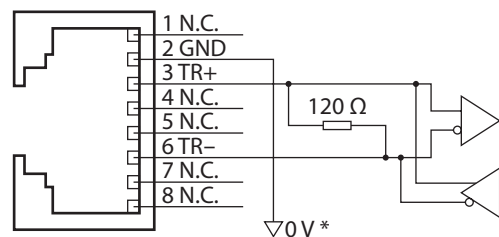

* The GND line is used in common with CN1 (not insulated)

5-4 Connecting the MECHATROLINK-II communication

Connect the MECHATROLINK-II communication cable to the MECHATROLINK-II communication connector (CN2-1 or CN2-2) of the **NETC01-M2**. For the MECHATROLINK-II communication cable, use a dedicated cable with connector. Other MECHATROLINK-II communication compatible products can be connected to the vacant connector. Connect a termination resistor to the **NETC01-M2** that is positioned at the end from the master device.

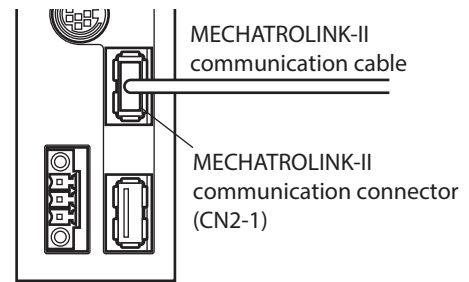

5-5 Connecting the data setter

Connect the communication cable for the support software or **OPX-2A** cable to the data edit connector (CN3) on the **NETC01-M2**.

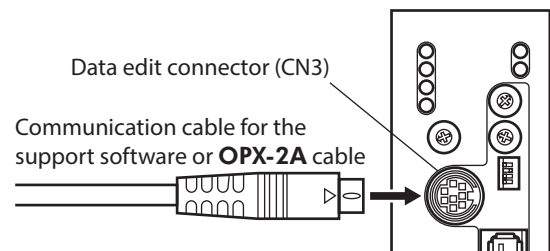

CAUTION

The power supply connector (CN1), MECHATROLINK-II communication connectors (CN2-1, CN2-2), data edit connector (CN3) and RS-485 communication connector (CN6) of the **NETC01-M2** are not electrically insulated. When grounding the positive terminal of the power supply, do not connect any equipment (PC, etc.) whose negative terminal is grounded. Doing so may cause the **NETC01-M2** and these equipment to short, damaging both.

6 Guidance

If you are new to the **NETC01-M2**, read this section to understand the operating methods along with the operation flow.

As an example, this chapter explains how to perform positioning operation for the “**CRK Series FLEX Built-in controller type** [described as the **CRD-KD** in this manual],” using the **NETC01-M2** via MECHATROLINK-II communication.



- Before operating the motor, check the condition of the surrounding area to ensure safety.
- Refer to “13-8 Parameter mode” on p.51 for how to set parameters.

STEP 1 Set the transmission rate, station address and address number

■ **Using the parameter**

1. Set the “Connection (address number 0)” parameter of the **NETC01-M2** to “1: Enable.”
2. Cycle the **NETC01-M2** power.



- “Connection” parameters will be enabled after the power is cycled.
- When setting the parameters of the **NETC01-M2**, use the **MEXE02** or **OPX-2A**.

■ **Using the switches**

● **Setting condition of CRD-KD**

- Address number of **CRD-KD**: 0
- Connection device of **CRD-KD**: Network converter

● **Setting condition of NETC01-M2**

- MECHATROLINK-II station address: 61h
- RS-485 transmission rate: 625 kbps
- Remote I/O occupied size: 16 bit mode
- Number of transmission bytes: 32 bytes

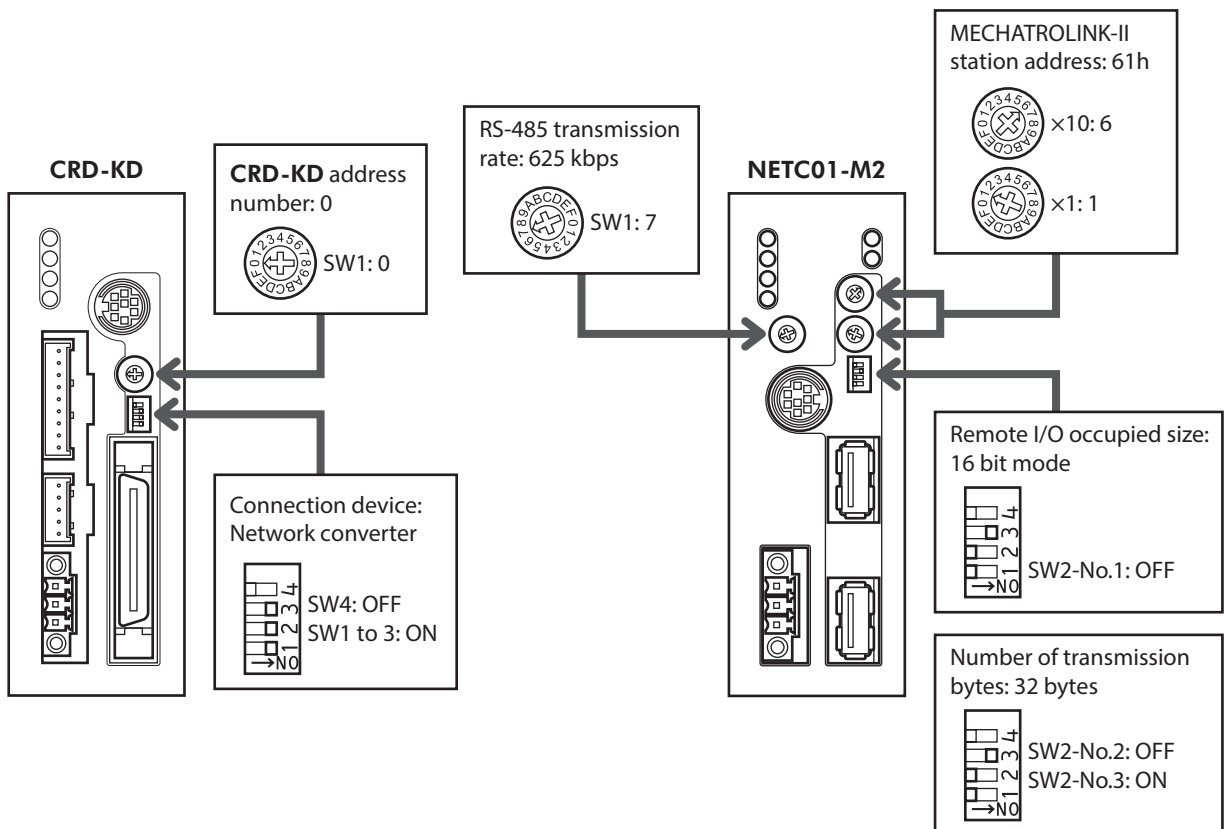

STEP 2 Check the connection and set the termination resistor

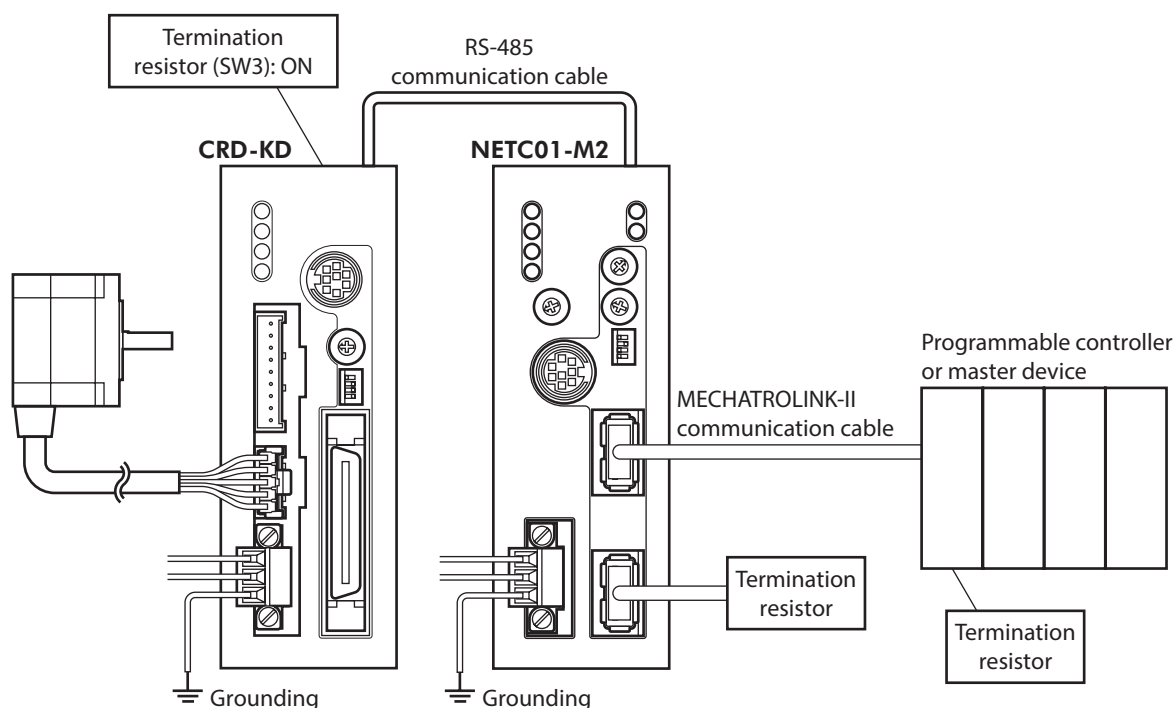

STEP 3 Turn on the power and check the setting

Check that the LED condition has become as shown in the figures.

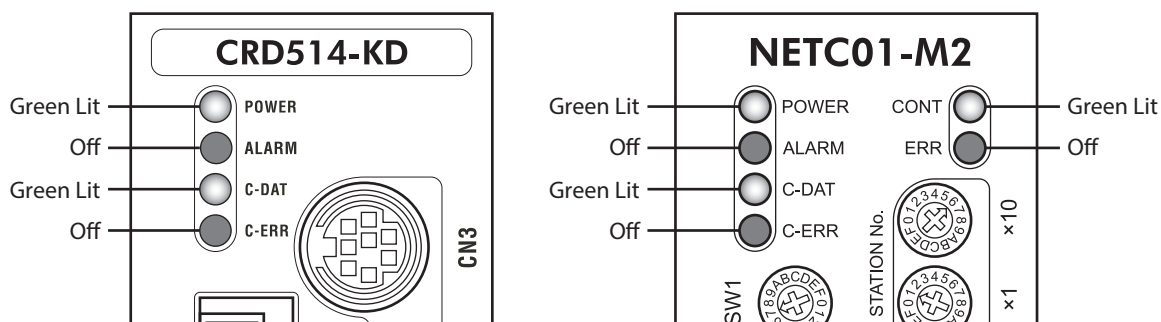

- When C-ERR (red) of the **CRD-KD** or **NETC01-M2** is lit: Check the transmission rate or address number of RS-485 communication.
- When ERR (red) of the **NETC01-M2** is lit: Check the type of the MECHATROLINK-II communication error.

STEP 4 Set the parameters of CRD-KD

Set the parameters of the **CRD-KD** using any of the **MEXE02**, **OPX-2A**, RS-485 communication or MECHATROLINK-II communication.

1. Set the "START input mode (1C00h)" parameter of the **CRD-KD** to "0: RS-485 communication."
(Initial setting: I/O)
2. Set the position (travel amount: 1001h) and operating speed (1101h) to the operation data No.1 of the **CRK-KD**.
3. Set the "Data No. input mode (1C0Dh)" parameter of the **CRD-KD** to "0: RS-485 communication."
(Initial setting: I/O)
4. Set the "STOP contact configuration (1C03h)" parameter of the **CRD-KD** to "0: Normally open."
(Initial setting: Normally closed)



- Operation data or parameters set via RS-485 communication or MECHATROLINK-II communication will be written to the RAM of the **CRD-KD**. The data stored in the RAM will be erased when turning off the power supply of the **CRD-KD**. When saving the data to the non-volatile memory, execute the "Batch NV memory write" command of the maintenance command.
- The operation data or parameters set by the **MEXE02** or **OPX-2A** will be saved to the non-volatile memory of the **CRD-KD**.
- The non-volatile memory can be rewritten approx. 100,000 times.

STEP 5 Execute positioning operation

Control the I/O signal of the **CRD-KD** using the I/O command (DATA_RWA: 50h) of MECHATROLINK-II communication.

1. Select the data No.1 by turning the M0 of the address number 0 to ON.
2. Execute positioning operation by turning the START of the address number 0 to ON.

STEP 6 Were you able to operate the motor properly?

How did it go? Were you able to operate the motor properly? If the motor does not function, check the following points:

- Is any alarm present in the **NETC01-M2** or **CRD-KD**?
- Are the address number, transmission rate and termination resistor set correctly?
- Are the "Connection" parameters of the **NETC01-M2** set correctly?
- Is the C-ERR LED lit? (RS-485 communication error)
- Is the ERR LED lit? (MECHATROLINK-II communication error)
- Is the operation data set correctly?
- Is the motor for the **CRD-KD** excited? Or is the excitation setting correct?
- Are the **CRD-KD** parameters set correctly?
- Is the STOP input of the **CRD-KD** I/O turned ON?

For more detailed settings and functions, refer to the following pages.

7 Setting

This chapter explains how to set the functions of the **NETC01-M2**.

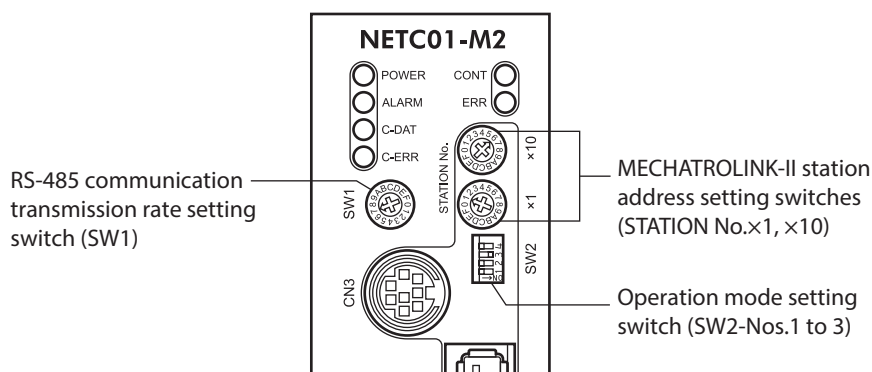

Note Be sure to turn off the **NETC01-M2** power before setting the switches. If the switches are set while the power is still on, the new switch settings will not become effective until the **NETC01-M2** power is cycled.

7-1 Transmission rate of RS-485 communication

Set the transmission rate using the transmission rate setting switch (SW1).

Factory setting 7 (625 kbps)

Note

- For the SW1, always set to "7." If the switch is set to the dial of "8" or higher, the communication switch setting error alarm will be generated when turning on the power. And do not set the switch to the dial of "0" to "6" because they cannot be used. (An alarm will not be generated.)
- For the transmission rate of the RS-485 communication compatible product, set to 625 kbps.

7-2 Operation mode

Set the remote I/O occupied size and number of transmission bytes for the RS-485 communication compatible product connecting to a **NETC01-M2**. Set the remote I/O occupied size using the operation mode setting switch SW2-No.1, and set the number of transmission bytes using the SW2-No.2 and No.3. If the operation mode is changed, cycle the power.

Factory setting No.1: OFF (Remote I/O occupied size: 16 bit mode)
No.2: OFF, No.3: ON (Number of transmission bytes: 32 bytes)

SW2	Description	Factory setting
No.1	Sets the remote I/O occupied size. OFF: 16 bit mode (Up to 8 units can be connected) ON: 8 bit mode (Up to 16 units can be connected)	OFF
No.2 No.3	Set the number of transmission bytes. No.2=OFF, No.3=OFF: 17 bytes No.2=OFF, No.3=ON: 32 bytes	No.2: OFF No.3: ON

Note The SW2-No.4 is not used.

7-3 Station address

Set the station address using the two MECHATROLINK-II station address setting switches (STATION No.×1 and ×10). When connecting two or more MECHATROLINK-II compatible products, do not set duplicate station address. Set the tens place with the "STATION No.×10" switch and the ones place with the "STATION No.×1" switch.

Setting range 60h to 7Fh

Factory setting 61h (×10: 6, ×1: 1)



00h to 5Fh and 80h to FFh cannot be used.

8 MECHATROLINK-II communication format

This chapter explains the MECHATROLINK-II communication format that the **NETC01-M2** supports.

8-1 Data format

The outline of the data format for MECHATROLINK-II communication is shown below. The **NETC01-M2** is compatible with the cyclic communication mode.

The cyclic communication mode of MECHATROLINK-II communication specifies that the header fields are 1 byte to 4 bytes and the data fields are 5 bytes and later.

	Byte	Command (Master to NETC01-M2)	Response (NETC01-M2 to master)
Header field	1	DATA_RWA (50h)	DATA_RWA (50h)
	2	OPTION	ALARM
	3		STATUS
	4		
Data field	5 to 31	Command data field	Response data field

8-2 Phase

The communication phases of MECHATROLINK-II communication are classified as follows.

Phase	Description
0	This is a state at power-on. When turning on the power for the master station and device station, operation switches to phase 1.
1	This is a state waiting for the connection establishment between the master station and device station.
2	Asynchronous communication between the master station and device station is enabled. Only asynchronous command can be used.
3	Synchronous communication between the master station and device station is enabled. Both asynchronous command and synchronous command can be used.
4	This is a state that the communication between the master station and device station is stopped and the connection is disconnected.
5	This is a state turning off the power for the master station and device station.

9 Details of command

This chapter explains the common commands and I/O command that the **NETC01-M2** supports.

Profile	Command code	Command	Description	Ref.
Common command	00h	NOP	This command is used as "no operation command."	p.20
	03h	ID_RD	This command is used to read the product information as ID data.	p.22
	05h	ALM_RD	This command is used to read the alarm code, warning code or MECHATROLINK-II communication error code that is currently occurred.	p.24
	06h	ALM_CLR	This command is used to reset the alarm, warning or MECHATROLINK-II communication error that is currently occurred.	p.24
	0Eh	CONNECT	This command is used to establish a connection of MECHATROLINK-II communication.	p.25
	0Fh	DISCONNECT	This command is used to release a connection of MECHATROLINK-II communication.	p.26
I/O command	50h	DATA_RWA	Operation commands to the RS-485 communication compatible product, reading and writing parameters, and monitoring can be executed via remote I/O or remote register.	p.27

9-1 No operation command (NOP: 00h)

This command is used as "no operation command." A response returns the present status.

■ Data format

Byte	Command (Master to NETC01-M2)	Response (NETC01-M2 to master)
1	NOP (00h)	NOP (00h)
2	Reserved (0h)	ALARM
3		STATUS
4		Reserved (0h)
5 to 15		Reserved (0h)
16	WDT	RWDT
17 to 31	Reserved (0h)	Reserved (0h)

■ Explanation of command

Device group	Common command group
Function group	Network command group
Communication type	Asynchronous command
Completion of command operation	Confirms by the response byte 1=NOP (=00h) and STATUS.CMDRDY=1.
Note	ALARM: Error code occurred in communication STATUS: Communication status

■ **ALARM**

Code	Name	Description	Phase at error	Transition phase after error	ALARM/WARNING	ALM-CLR
01h	Invalid Command	Unsupported command • Executed the command that was not implemented.	P1 to P4	Phase not changed	WARNING	Possible
02h	Command Not Allowed	Command execution condition error • The command that has been sent is inconsistency with the communication phase. • The command execution conditions are not met.	P2, P3			
03h	Invalid Data	Outside the range of command data • The data in the command is not correct.	P2, P3			

■ **STATUS bit allocations**

Bit7	Bit6	Bit5	Bit4	Bit3	Bit2	Bit1	Bit0
Vendor-specific					CMDRDY	WARNG	ALARM
Bit15	Bit14	Bit13	Bit12	Bit11	Bit10	Bit9	Bit8
Vendor-specific							

Explanation of bit field

Item	Definition	Description
ALARM	0: No alarm 1: Alarm status	If the MECHATROLINK-II communication error has occurred between the master station and NETC01-M2 , the STATUS bit0 becomes "1" (ALARM=1). Even if an alarm generates in the NETC01-M2 or RS-485 communication compatible product, it will not become "1." Refer to p.39 for the NETC01-M2 alarm.
WARNG	0: No warning 1: Warning status	If "unsupported command," "command execution condition error" or "outside the range of command data" has occurred between the master station and NETC01-M2 , the STATUS bit1 becomes "1" (WARNING=1). Even if a warning generates in the NETC01-M2 or RS-485 communication compatible product, it will not become "1." Refer to p.42 for the NETC01-M2 warning.
CMDRDY	0: Command cannot be accepted. 1: Command can be accepted.	CMDRDY=0 (the STATUS bit2 is equal to "0") represents that the NETC01-M2 is executing command processing. When the STATUS bit2 becomes "1" (CMDRDY=1), a new command can be accepted.

■ **WDT/RWDT**

When synchronization has been established, the watchdog timer (WDT) executes checking. Updating the WDT can be refreshed even if synchronization has not been established.

● **WDT**

Bit7	Bit6	Bit5	Bit4	Bit3	Bit2	Bit1	Bit0
SN: Copy of RSN in RWDT				MN: Incremented by 1 each communication cycle (Master station WDT count)			

● **RWDT**

Bit7	Bit6	Bit5	Bit4	Bit3	Bit2	Bit1	Bit0
RSN: Incremented by 1 each communication cycle (Device station WDT count)				RMN: Copy of MN in WDT			

9-2 Read ID command (ID_RD: 03h)

This command is used to read the product information as ID data. Select ID data by specifying the DEVICE_CODE. Refer to the "DEVICE_CODE list" on p.23 for details.

■ **Data format**

Byte	Command (Master to NETC01-M2)	Response (NETC01-M2 to master)
1	ID_RD (03h)	ID_RD (03h)
2	Reserved (0h)	ALARM
3		STATUS
4		
5	DEVICE_CODE	DEVICE_CODE
6	OFFSET	OFFSET
7	SIZE	SIZE
8 to 15	Reserved (0h)	ID
16	WDT	RWDT
17 to 31	Reserved (0h)	Reserved (0h)

■ **Explanation of command**

Device group	Common command group
Function group	Data communication command group
Communication type	Asynchronous command
Completion of command operation	Confirms by the response byte 1=ID_RD (=03h), STATUS.CMDRDY=1, DEVICE_CODE, OFFSET and SIZE.
Note	DEVICE_CODE: Device code OFFSET: Read offset Size: Read data size (byte)

■ **DEVICE_CODE list**

DEVICE_CODE	Description	Data size	Data type																																																																																																
00h	Product model	32 char	ASCII																																																																																																
	This is a code to specify the product model.																																																																																																		
	<table border="1"> <tr> <td>00</td><td>01</td><td>02</td><td>03</td><td>04</td><td>05</td><td>06</td><td>07</td><td>08</td><td>09</td><td>0A</td><td>0B</td><td>0C</td><td>0D</td><td>0E</td><td>0F</td> </tr> <tr> <td>N</td><td>E</td><td>T</td><td>C</td><td>0</td><td>1</td><td>-</td><td>M</td><td>2</td><td>00</td><td></td><td></td><td></td><td></td><td></td><td></td> </tr> <tr> <td>10</td><td>11</td><td>12</td><td>13</td><td>14</td><td>15</td><td>16</td><td>17</td><td>18</td><td>19</td><td>1A</td><td>1B</td><td>1C</td><td>1D</td><td>1E</td><td>1F</td> </tr> <tr> <td></td><td></td><td></td><td></td><td></td><td></td><td></td><td></td><td></td><td></td><td></td><td></td><td></td><td></td><td></td><td></td> </tr> </table>			00	01	02	03	04	05	06	07	08	09	0A	0B	0C	0D	0E	0F	N	E	T	C	0	1	-	M	2	00							10	11	12	13	14	15	16	17	18	19	1A	1B	1C	1D	1E	1F																																																
	00	01	02	03	04	05	06	07	08	09	0A	0B	0C	0D	0E	0F																																																																																			
N	E	T	C	0	1	-	M	2	00																																																																																										
10	11	12	13	14	15	16	17	18	19	1A	1B	1C	1D	1E	1F																																																																																				
* Data end delimiter: Null code (00h) is added at the end of each character string.																																																																																																			
01h	Manufacture serial	32 char	ASCII																																																																																																
	This is a manufacture serial number.																																																																																																		
	<table border="1"> <tr> <td>00</td><td>01</td><td>02</td><td>03</td><td>04</td><td>05</td><td>06</td><td>07</td><td>08</td><td>09</td><td>0A</td><td>0B</td><td>0C</td><td>0D</td><td>0E</td><td>0F</td> </tr> <tr> <td>00</td><td></td><td></td><td></td><td></td><td></td><td></td><td></td><td></td><td></td><td></td><td></td><td></td><td></td><td></td><td></td> </tr> <tr> <td>10</td><td>11</td><td>12</td><td>13</td><td>14</td><td>15</td><td>16</td><td>17</td><td>18</td><td>19</td><td>1A</td><td>1B</td><td>1C</td><td>1D</td><td>1E</td><td>1F</td> </tr> <tr> <td></td><td></td><td></td><td></td><td></td><td></td><td></td><td></td><td></td><td></td><td></td><td></td><td></td><td></td><td></td><td></td> </tr> </table>			00	01	02	03	04	05	06	07	08	09	0A	0B	0C	0D	0E	0F	00																10	11	12	13	14	15	16	17	18	19	1A	1B	1C	1D	1E	1F																																																
	00	01	02	03	04	05	06	07	08	09	0A	0B	0C	0D	0E	0F																																																																																			
00																																																																																																			
10	11	12	13	14	15	16	17	18	19	1A	1B	1C	1D	1E	1F																																																																																				
* Data end delimiter: Null code (00h) is added at the end of each character string.																																																																																																			
02h	Device version	32 char	ASCII																																																																																																
	This is a code to specify the device version.																																																																																																		
	<table border="1"> <tr> <td>00</td><td>01</td><td>02</td><td>03</td><td>04</td><td>05</td><td>06</td><td>07</td><td>08</td><td>09</td><td>0A</td><td>0B</td><td>0C</td><td>0D</td><td>0E</td><td>0F</td> </tr> <tr> <td>0</td><td>1</td><td>.</td><td>0</td><td>0</td><td>00</td><td></td><td></td><td></td><td></td><td></td><td></td><td></td><td></td><td></td><td></td> </tr> <tr> <td>10</td><td>11</td><td>12</td><td>13</td><td>14</td><td>15</td><td>16</td><td>17</td><td>18</td><td>19</td><td>1A</td><td>1B</td><td>1C</td><td>1D</td><td>1E</td><td>1F</td> </tr> <tr> <td></td><td></td><td></td><td></td><td></td><td></td><td></td><td></td><td></td><td></td><td></td><td></td><td></td><td></td><td></td><td></td> </tr> </table>			00	01	02	03	04	05	06	07	08	09	0A	0B	0C	0D	0E	0F	0	1	.	0	0	00											10	11	12	13	14	15	16	17	18	19	1A	1B	1C	1D	1E	1F																																																
	00	01	02	03	04	05	06	07	08	09	0A	0B	0C	0D	0E	0F																																																																																			
0	1	.	0	0	00																																																																																														
10	11	12	13	14	15	16	17	18	19	1A	1B	1C	1D	1E	1F																																																																																				
* Data end delimiter: Null code (00h) is added at the end of each character string.																																																																																																			
0Fh	Vendor code	48 byte	BIN/ASCII																																																																																																
	This is a code to specify the vendor.																																																																																																		
	<table border="1"> <tr> <td>00</td><td>01</td><td>02</td><td>03</td><td>04</td><td>05</td><td>06</td><td>07</td><td>08</td><td>09</td><td>0A</td><td>0B</td><td>0C</td><td>0D</td><td>0E</td><td>0F</td> </tr> <tr> <td>05</td><td>00</td><td></td><td></td><td></td><td></td><td></td><td></td><td></td><td></td><td></td><td></td><td></td><td></td><td></td><td></td> </tr> <tr> <td>10</td><td>11</td><td>12</td><td>13</td><td>14</td><td>15</td><td>16</td><td>17</td><td>18</td><td>19</td><td>1A</td><td>1B</td><td>1C</td><td>1D</td><td>1E</td><td>1F</td> </tr> <tr> <td>O</td><td>R</td><td>I</td><td>E</td><td>N</td><td>T</td><td>A</td><td>L</td><td></td><td>M</td><td>O</td><td>T</td><td>O</td><td>R</td><td></td><td>C</td> </tr> <tr> <td>10</td><td>11</td><td>12</td><td>13</td><td>14</td><td>15</td><td>16</td><td>17</td><td>18</td><td>19</td><td>1A</td><td>1B</td><td>1C</td><td>1D</td><td>1E</td><td>1F</td> </tr> <tr> <td>o</td><td>.</td><td>,</td><td>L</td><td>T</td><td>D</td><td>.</td><td>00</td><td></td><td></td><td></td><td></td><td></td><td></td><td></td><td></td> </tr> </table>			00	01	02	03	04	05	06	07	08	09	0A	0B	0C	0D	0E	0F	05	00															10	11	12	13	14	15	16	17	18	19	1A	1B	1C	1D	1E	1F	O	R	I	E	N	T	A	L		M	O	T	O	R		C	10	11	12	13	14	15	16	17	18	19	1A	1B	1C	1D	1E	1F	o	.	,	L	T	D	.	00								
	00	01	02	03	04	05	06	07	08	09	0A	0B	0C	0D	0E	0F																																																																																			
05	00																																																																																																		
10	11	12	13	14	15	16	17	18	19	1A	1B	1C	1D	1E	1F																																																																																				
O	R	I	E	N	T	A	L		M	O	T	O	R		C																																																																																				
10	11	12	13	14	15	16	17	18	19	1A	1B	1C	1D	1E	1F																																																																																				
o	.	,	L	T	D	.	00																																																																																												
* Data end delimiter: Null code (00h) is added at the end of each character string.																																																																																																			

9-3 Read alarm or warning command (ALM_RD: 05h)

This command is used to read the alarm code, warning code or MECHATROLINK-II communication error code that is currently occurred.

■ Data format

Byte	Command (Master to NETC01-M2)	Response (NETC01-M2 to master)
1	ALM_RD (05h)	ALM_RD (05h)
2	Reserved (0h)	ALARM
3		STATUS
4		
5	ALM_RD_MODE	ALM_RD_MODE
6 to 15	Reserved (0h)	ALM_DATA
16	WDT	RWDT
17 to 31	Reserved (0h)	Reserved (0h)

■ Explanation of command

Device group	Common command group
Function group	Control command group
Communication type	Asynchronous command
Completion of command operation	Confirms by the response byte 1=ALM_RD (=05h) and STATUS.CMDRDY=1.
Note	ALM_RD_MODE 0: Reads the present alarm or warning status.

9-4 Clear alarm or warning command (ALM_CLR: 06h)

This command is used to reset the MECHATROLINK-II communication error that is currently occurred.

Note Only the MECHATROLINK-II communication error can be reset by the "clear alarm or warning command." To reset the alarm and warning of the **NETC01-M2**, cycle the power.

■ Data format

Byte	Command (Master to NETC01-M2)	Response (NETC01-M2 to master)
1	ALM_CLR (06h)	ALM_CLR (06h)
2	Reserved (0h)	ALARM
3		STATUS
4		
5	ALM_CLR_MODE	ALM_CLR_MODE
6 to 15	Reserved (0h)	Reserved (0h)
16	WDT	RWDT
17 to 31	Reserved (0h)	Reserved (0h)

■ Explanation of command

Device group	Common command group
Function group	Control command group
Communication type	Asynchronous command
Completion of command operation	Confirms by the response byte 1=ALM_CLR (=06h) and STATUS.CMDRDY=1.
Note	ALM_CLR_MODE 0: Resets the MECHATROLINK-II communication error that is currently occurred.

9-5 Establish connection command (CONNECT: 0Eh)

This command is used to establish the MECHATROLINK-II communication connection.

■ Data format

Byte	Command (Master to NETC01-M2)	Response (NETC01-M2 to master)
1	CONNECT (0Eh)	CONNECT (0Eh)
2	Reserved (0h)	ALARM
3		STATUS
4		Reserved (0h)
5	VER (21h)	VER (21h)
6	COM_MODE	COM_MODE
7	COM_TIME	COM_TIME
8 to 15	Reserved (0h)	Reserved (0h)
16	WDT	RWDT
17 to 31	Reserved (0h)	Reserved (0h)

■ Explanation of command

Device group	Common command group
Function group	Network command group
Communication type	Asynchronous command
Completion of command operation	Confirms by the response byte 1=CONNECT (=0Eh), STATUS.CMDRDY=1, VER, COM_MODE and COM_TIME.
Note	<ul style="list-style-type: none"> • VER: Version number in the application layer • COM_MODE: Communication mode

■ **COM_MODE bit allocations**

Bit7	Bit6	Bit5	Bit4	Bit3	Bit2	Bit1	Bit0
DATA_EXP	0	0	0	DTMOD		SYNCMOD	0

Explanation of bit field

Item	Description
DATA_EXP	Data area extension 0: Padded with zero (0) for the byte 17 to byte 31 1: The byte 17 to byte 31 are extended areas (effective with 32-byte mode)
DTMODE	Communication mode 00: Single transmission 01: Consecutive transmission (Not used in the NETC01-M2) 10, 11: Reserved
SYNCMODE	Synchronous setting 0: Asynchronous communication (Detecting the watchdog data error is disabled and synchronous command cannot be used.) 1: Synchronous command (Not used in the NETC01-M2)

9-6 Release connection command (DISCONNECT: 0Fh)

This command is used to release a connection of MECHATROLINK-II communication. This command is given priority over other commands. When the DISCONNECT command is received while processing the other command, the current command is stopped processing and the connection is released.

■ **Data format**

Byte	Command (Master to NETC01-M2)	Response (NETC01-M2 to master)
1	DISCONNECT (0Fh)	DISCONNECT (0Fh)
2	Reserved (0h)	ALARM
3		STATUS
4		Reserved (0h)
5 to 15		Reserved (0h)
16	WDT	RWDT
17 to 31	Reserved (0h)	Reserved (0h)

■ **Explanation of command**

Device group	Common command group
Function group	Network command group
Communication type	Asynchronous command
Completion of command operation	Controls the command transmitting time of the mater station as at least two communication cycles.

9-7 Data READ/WRITE_A command (DATA_RWA: 50h)

Operation commands to the RS-485 communication compatible product, reading and writing parameters, and monitoring can be executed via remote I/O or remote register.

● Remote I/O

Remote I/O is one of the data used in communication between the master station and RS-485 communication compatible product. The control like the ON-OFF switching of I/O signals can be executed using serial communication.

When remote I/O of the **NETC01-M2** is assigned to the register of the master station, it is possible to control using remote I/O via the **NETC01-M2**. The following functions can be executed using remote I/O.

- Controls the ON-OFF status of the input signal to the RS-485 communication compatible product.
- Checks the output signal from the RS-485 communication compatible product.

● Remote register

Remote register is one of the data used in communication between the master station and RS-485 communication compatible product. Reading and writing the numerical number can be executed using serial communication.

When remote register of the **NETC01-M2** is assigned to the register of the master station, it is possible to control using remote register via the **NETC01-M2**. The following functions can be executed using remote register.

- Reads the parameters from the RS-485 communication compatible product.
- Writes the parameters to the RS-485 communication compatible product.
- Monitors the status of the RS-485 communication compatible product.

■ Data format

Byte	Command (Master to NETC01-M2)	Response (NETC01-M2 to master)
1	DATA_RWA (50h)	DATA_RWA (50h)
2	OPTION	ALARM
3		STATUS
4		
5 to 16	OUTPUT	INPUT
17 to 31	OUTPUT	INPUT

■ Explanation of command

Device group	I/O command group
Function group	Data communication command group
Communication type	Asynchronous command
Completion of command operation	Confirms by the response byte 1=DATA_RWA (=50h) and STATUS. CMDRDY=1.
Note	<ul style="list-style-type: none"> • This command can be used in the phase 2 and 3. • OUTPUT: Output data • INPUT: Input data • Refer to the "I/O data."

■ Connection status

The connection status with the RS-485 communication compatible product can be monitored by the response of the DATA_RWA command. For the connection status shown in the next section "I/O data," when the master station properly communicates with the RS-485 communication compatible product, the bit corresponding to the address number shown in the table next becomes "1." If the connection setting is disabled or if the communication error has occurred, the bit becomes "0."

Bit7	Bit6	Bit5	Bit4	Bit3	Bit2	Bit1	Bit0
Address number 7	Address number 6	Address number 5	Address number 4	Address number 3	Address number 2	Address number 1	Address number 0
Address number 15	Address number 14	Address number 13	Address number 12	Address number 11	Address number 10	Address number 9	Address number 8

■ **I/O data**

The OUTPUT and INPUT respectively correspond to the command and response of the data field as shown below. Controlling the I/O signal of the RS-485 communication compatible product, reading and writing operation data or parameters, and monitoring can be executed.

In the following cases, the most significant bit of the register address number response becomes "1."

- When "Communication (address number)" parameter specifies the address number of "0: Disabled"
- When the power supply of the RS-485 communication compatible product is not turned on

- **Remote I/O occupied size: 16-bit mode**
Number of transmission bytes: 17-byte mode

Byte	Part	Type	Command (Master to NETC01-M2)	Response (NETC01-M2 to master)	
1	Header field	-	DATA_RWA (50h)	DATA_RWA (50h)	
2			OPTION	ALARM	
3				STATUS	
4					
5	Data field	-	Reserved	Connection status	
6					
7		Remote I/O	Address number "0" remote I/O input	Address number "0" remote I/O output	
8			Address number "1" remote I/O input	Address number "1" remote I/O output	
9			Address number "2" remote I/O input	Address number "2" remote I/O output	
10			Address number "3" remote I/O input	Address number "3" remote I/O output	
11		-	-	Reserved	Reserved
12					
13					
14					
15	-	-	Reserved	Reserved	
16					

- Remote I/O occupied size: 16-bit mode
Number of transmission bytes: 32-byte mode

Byte	Part	Type	Command (Master to NETC01-M2)	Response (NETC01-M2 to master)	
1	Header field	-	DATA_RWA (50h)	DATA_RWA (50h)	
2			OPTION	ALARM	
3				STATUS	
4					
5	Data field	-	Reserved	Connection status	
6					
7		Remotel/O		Address number "0" remote I/O input	Address number "0" remote I/O output
8				Address number "1" remote I/O input	Address number "1" remote I/O output
9				Address number "2" remote I/O input	Address number "2" remote I/O output
10				Address number "3" remote I/O input	Address number "3" remote I/O output
11				Address number "4" remote I/O input	Address number "4" remote I/O output
12				Address number "5" remote I/O input	Address number "5" remote I/O output
13				Address number "6" remote I/O input	Address number "6" remote I/O output
14				Address number "7" remote I/O input	Address number "7" remote I/O output
15				Address number "8" remote I/O input	Address number "8" remote I/O output
16				Address number "9" remote I/O input	Address number "9" remote I/O output
17		Remote register		Register address number	Register address number response
18				Command code + TRIG	Command code response + TRIG response + STATUS
19				DATA	DATA response
20					
21					
22					
23					
24					
25					
26					
27 to 30					
31			-	Reserved	Reserved

- Remote I/O occupied size: 8-bit mode
Number of transmission bytes: 17-byte mode

Byte	Part	Type	Command (Master to NETC01-M2)	Response (NETC01-M2 to master)
1	Header field	-	DATA_RWA (50h)	DATA_RWA (50h)
2			OPTION	ALARM
3				STATUS
4				
5	Data field	-	Reserved	Connection status
6				
7		Remote I/O	Address number "0" remote I/O input	Address number "0" remote I/O output
8			Address number "1" remote I/O input	Address number "1" remote I/O output
9			Address number "2" remote I/O input	Address number "2" remote I/O output
10			Address number "3" remote I/O input	Address number "3" remote I/O output
11			Address number "4" remote I/O input	Address number "4" remote I/O output
12			Address number "5" remote I/O input	Address number "5" remote I/O output
13			Address number "6" remote I/O input	Address number "6" remote I/O output
14			Address number "7" remote I/O input	Address number "7" remote I/O output
15		-	Reserved	Reserved

- Remote I/O occupied size: 8-bit mode
Number of transmission bytes: 32-byte mode

Byte	Part	Type	Command (Master to NETC01-M2)	Response (NETC01-M2 to master)	
1	Header field	-	DATA_RWA (50h)	DATA_RWA (50h)	
2			OPTION	ALARM	
3				STATUS	
4					
5	Data field	-	Reserved	Connection status	
6					
7		Remotel/O	Address number "0" remote I/O input	Address number "0" remote I/O output	
8			Address number "1" remote I/O input	Address number "1" remote I/O output	
9			Address number "2" remote I/O input	Address number "2" remote I/O output	
10			Address number "3" remote I/O input	Address number "3" remote I/O output	
11			Address number "4" remote I/O input	Address number "4" remote I/O output	
12			Address number "5" remote I/O input	Address number "5" remote I/O output	
13			Address number "6" remote I/O input	Address number "6" remote I/O output	
14			Address number "7" remote I/O input	Address number "7" remote I/O output	
15			Address number "8" remote I/O input	Address number "8" remote I/O output	
16			Address number "9" remote I/O input	Address number "9" remote I/O output	
17			Address number "10" remote I/O input	Address number "10" remote I/O output	
18			Address number "11" remote I/O input	Address number "11" remote I/O output	
19			Address number "12" remote I/O input	Address number "12" remote I/O output	
20			Address number "13" remote I/O input	Address number "13" remote I/O output	
21			Address number "14" remote I/O input	Address number "14" remote I/O output	
22		Address number "15" remote I/O input	Address number "15" remote I/O output		
23		Remote register		Register address number	Register address number response
24				Command code + TRIG	Command code response + TRIG_R + STATUS
25					
26					
27 to 30			DATA	DATA response	
31		-	Reserved	Reserved	

9-8 Timing chart of the data READ/WRITE_A command

The command codes in the following timing charts are examples of the **AR** Series FLEX DC power input Built-in controller type.

TM: Communication cycle between the master station and **NETC01-M2**

TS: Communication cycle between the **NETC01-M2** and RS-485 communication compatible product.

■ When the power supply is turned on (remote I/O)

1. Turn on the power supply of the **NETC01-M2**.
2. Turn on the power supply of the RS-485 communication compatible product.
3. Check the connection status is turned from OFF to ON.

[Power supply input]

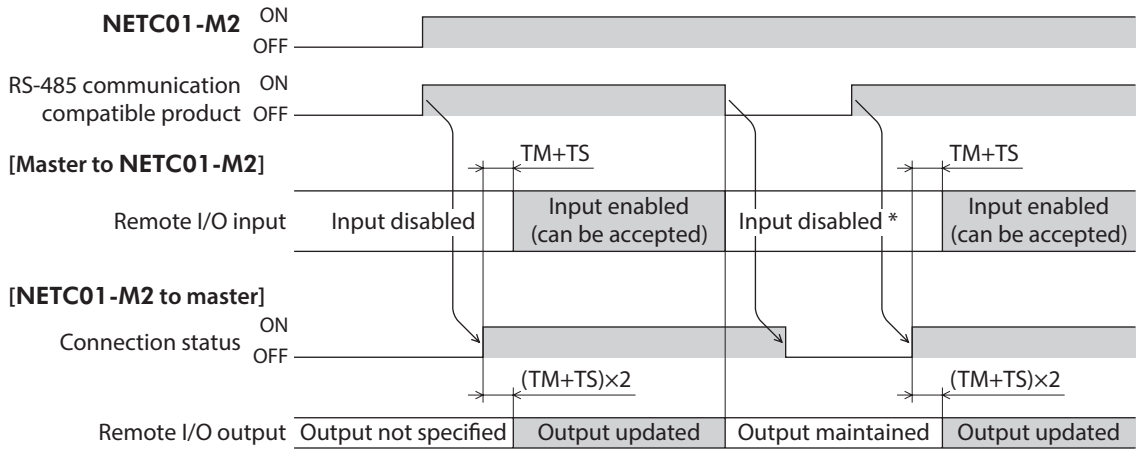

* When the connection status is OFF, turn the signals to start operation (START, HOME etc.) to OFF.

■ When the power supply is turned on (remote register)

1. Turn on the power supply of the **NETC01-M2**.
2. Turn on the power supply of the RS-485 communication compatible product.
3. Check the connection status is turned from OFF to ON. For the next step, refer to the next section “read parameter and operation data (remote register).”

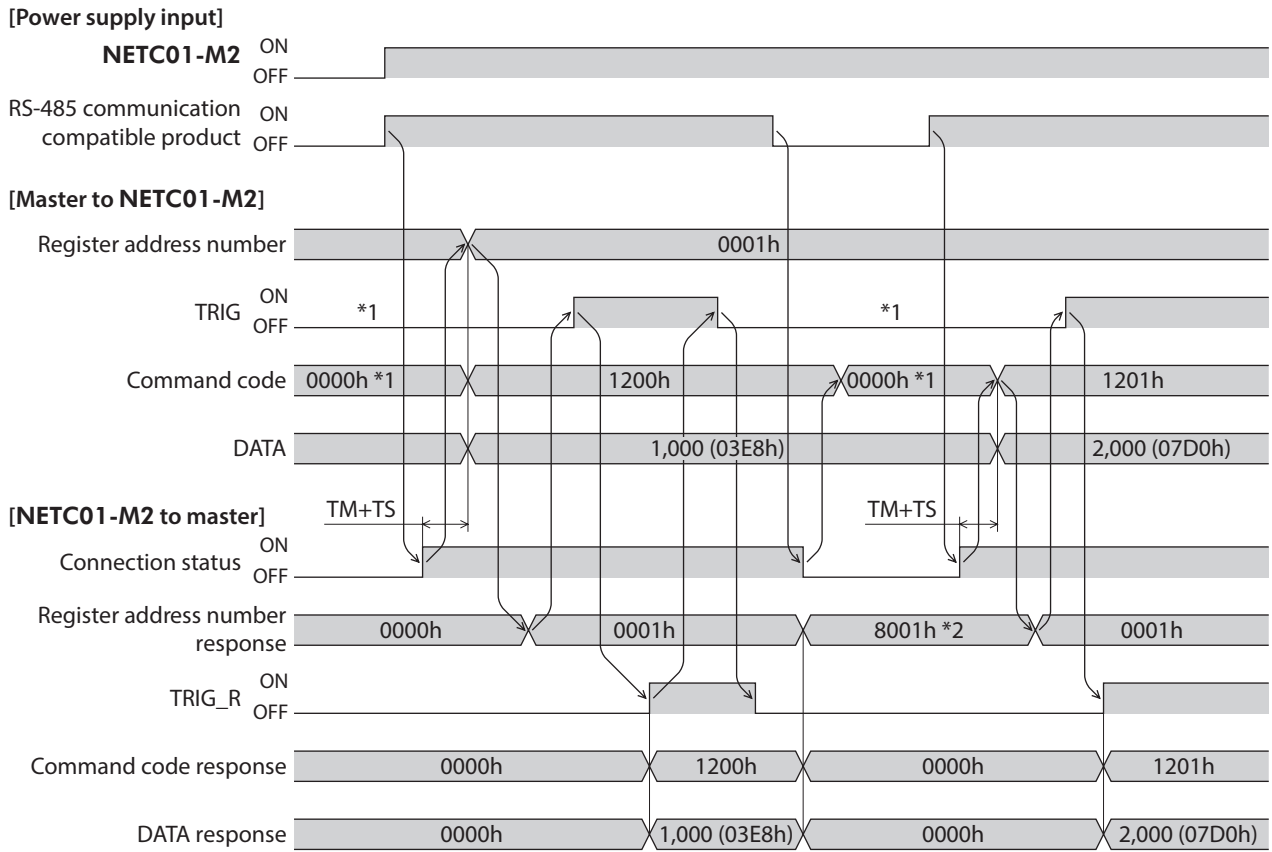

*1 When the connection status is OFF, set the command code to “0000h” and turn the TRIG to OFF.

*2 When the power supply of the RS-485 communication compatible product is OFF, the most significant bit of the register address number response becomes “1.”

■ **Read parameters and operation data (remote register)**

1. Specify the register address number.
2. Check the register address number response.
3. Turn the TRIG from OFF to ON. The selected parameter or operation data is started reading.
4. After checking the TRIG_R was turned from OFF to ON, check the command code response and DATA response.
5. Turn the TRIG from ON to OFF, and check that the TRIG_R was turned from ON to OFF.

When reading the “position (1,000)” of the operation data No.0

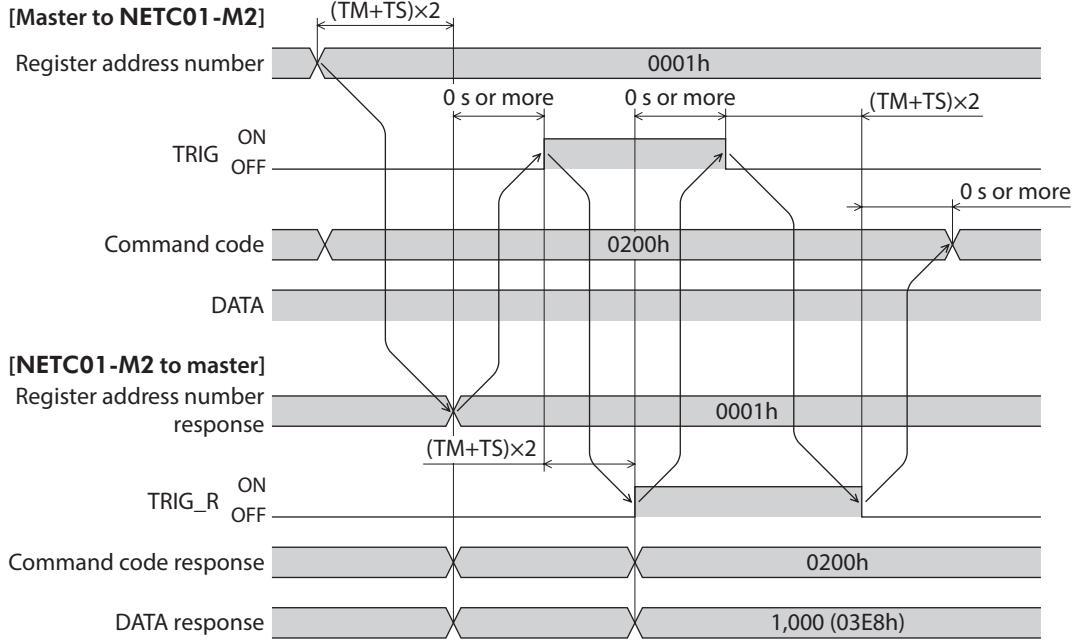

■ Write parameters and operation data (remote register)

1. Specify the register address number.
2. Check the register address number response.
3. Turn the TRIG from OFF to ON. The selected parameter or operation data is started writing.
4. After checking the TRIG_R was turned from OFF to ON, check the command code response and DATA response.
5. Turn the TRIG from ON to OFF, and check that the TRIG_R was turned from ON to OFF.

When writing 1,000 to the “position” of the operation data No.0

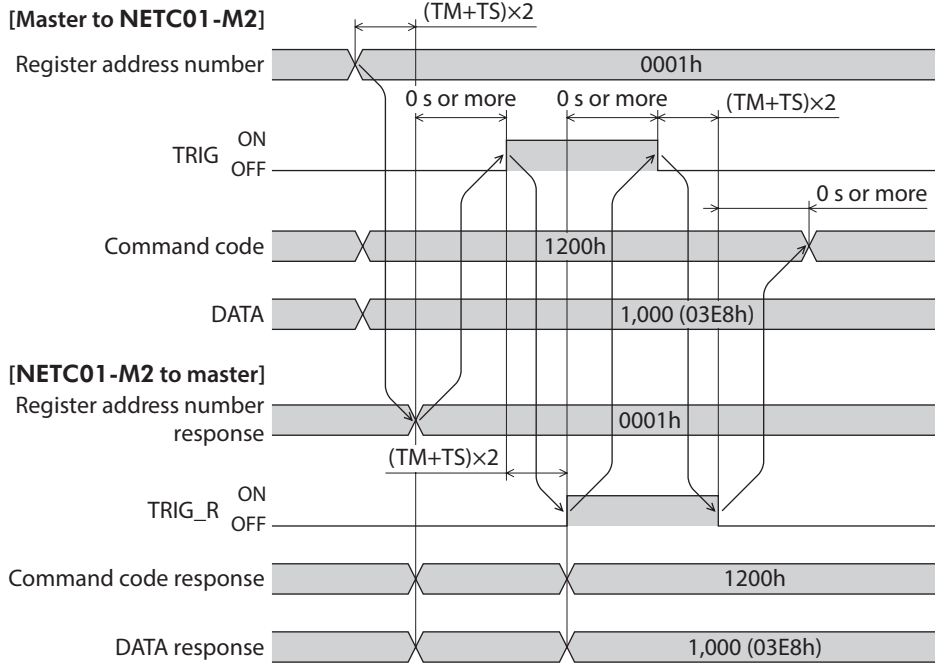

■ Maintenance (remote register)

1. Specify the register address number.
2. Check the register address number response.
3. Turn the TRIG from OFF to ON. The selected maintenance command is executed.
4. After checking the TRIG_R was turned from OFF to ON, check the command code response and DATA response.
5. Turn the TRIG from ON to OFF, and check that the TRIG_R was turned from ON to OFF.

When executing "batch NV memory write"

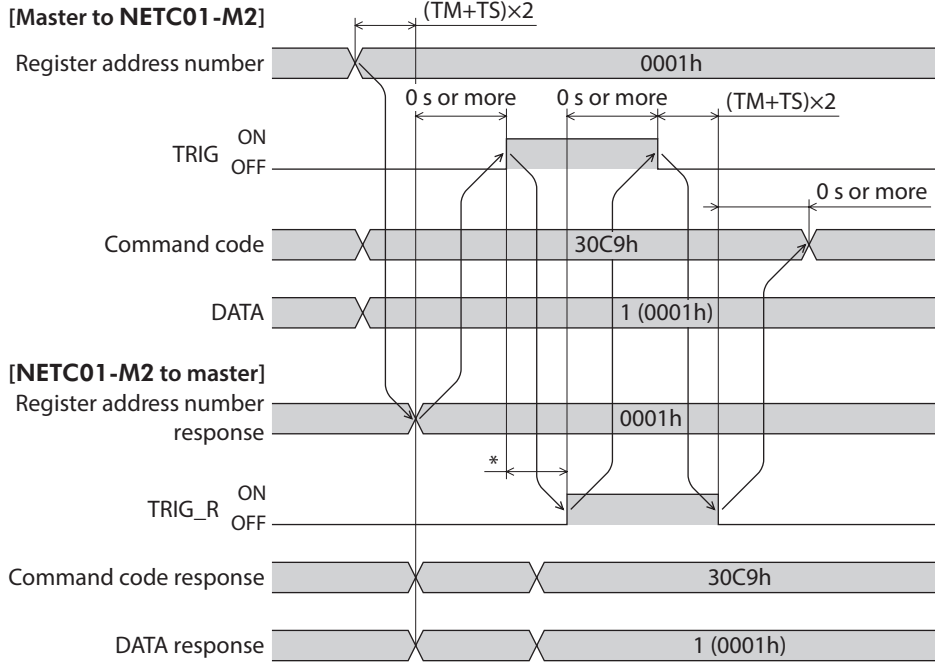

* It varies depending on the type of the RS-485 communication compatible products or commands.

■ Monitor (remote register)

1. Specify the register address number.
2. Check the register address number response.
3. Turn the TRIG from OFF to ON. The selected monitor command is executed.
4. After checking the TRIG_R was turned from OFF to ON, check the command code response and DATA response. The DATA response value is updated while the TRIG is ON.
5. Turn the TRIG from ON to OFF, and check that the TRIG_R was turned from ON to OFF.

When monitoring the "command position"

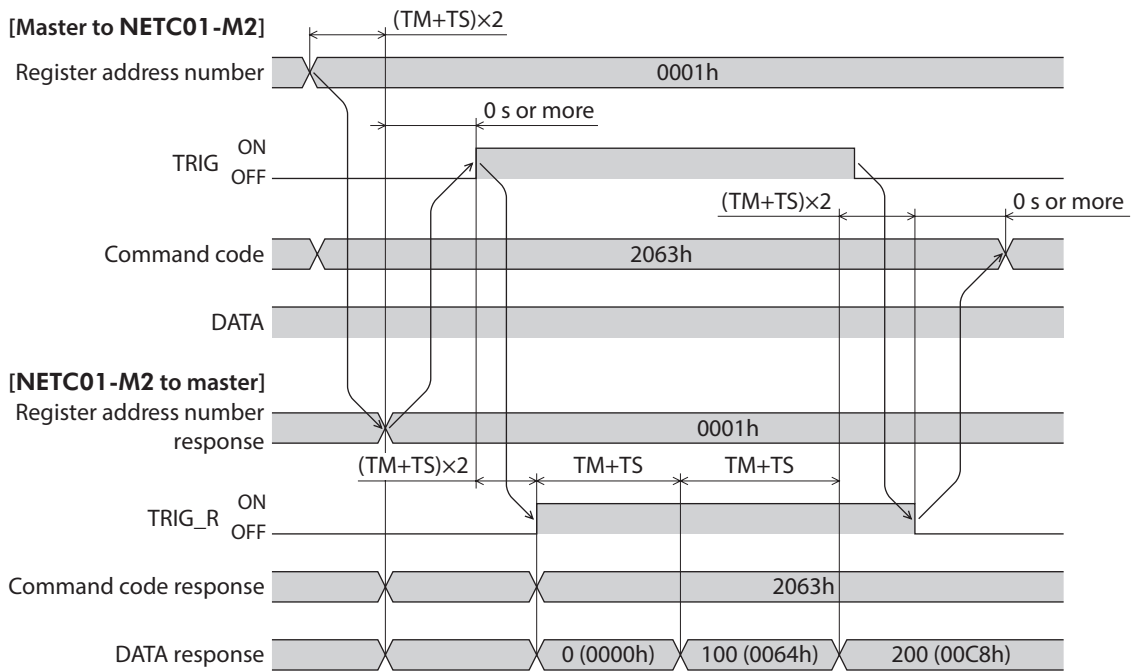

■ **When an error has occurred (remote register)**

1. Specify the register address number.
2. Check the register address number response.
3. Turn the TRIG from OFF to ON. The selected parameter or operation data is started writing.
4. When the written value is an error, the STATUS is turned from OFF to ON. Check the command code and DATA.
5. Turn the TRIG from ON to OFF, and reset the error status.

Note If an error has occurred in data transfer, the STATUS is turned ON.

When specifying data that is outside the setting range (write 1,000 to the “STOP input action” parameter)

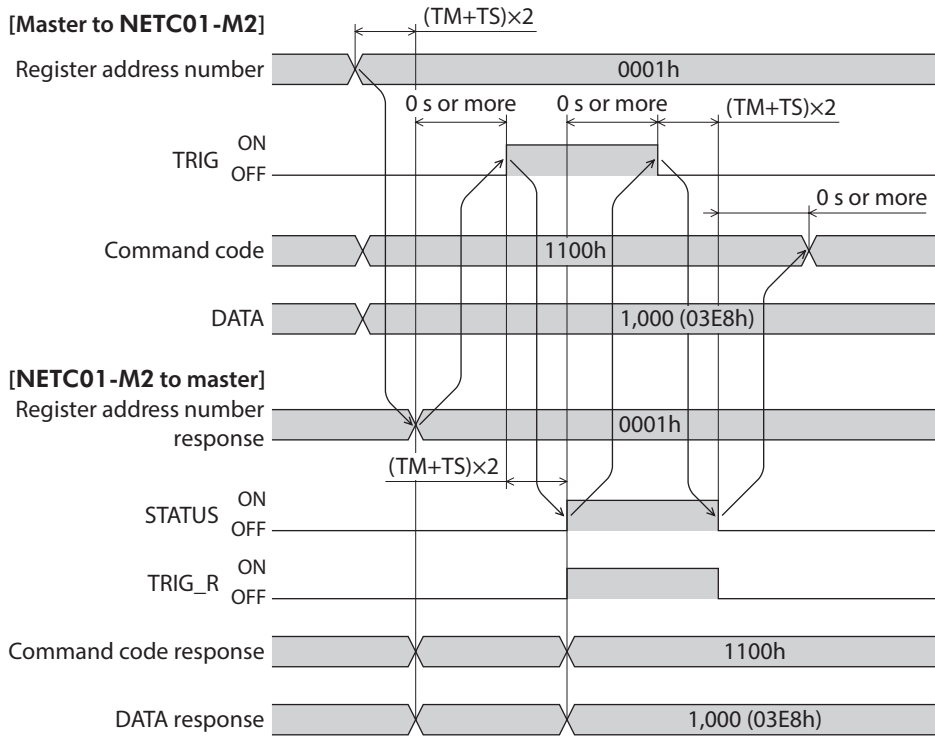

10 Troubleshooting and remedial actions

The **NETC01-M2** provides alarms that are designed to protect the **NETC01-M2** from poor connection, error in operation, etc. (protective functions), as well as warnings that are output before the corresponding alarms generate (warning functions).

10-1 Alarms and MECHATROLINK-II communication error

If an alarm has generated, the ALARM LED of the **NETC01-M2** blinks.
 When the MECHATROLINK-II communication error has occurred, the ERR LED blinks.

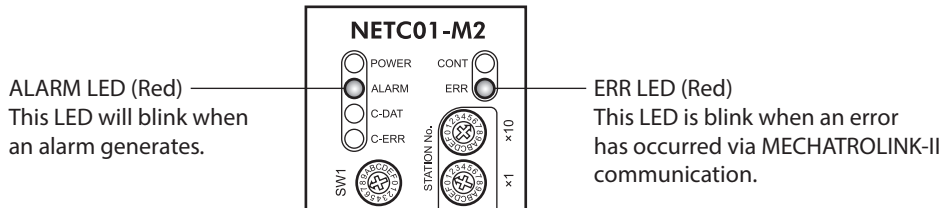

■ When an alarm in the NETC01-M2 unit was generated

If an alarm in the **NETC01-M2** unit has generated, RS-485 communication is stopped and the ALARM LED blinks. The present alarm can be checked by counting the number of times the ALARM LED blinks. The present alarm can be also checked using the **MEXE02** or **OPX-2A**.

You can check the records of up to 10 most recent alarms starting from the latest one, or clear the alarm records.

● ALARM LED status (Example: RS-485 communication error)

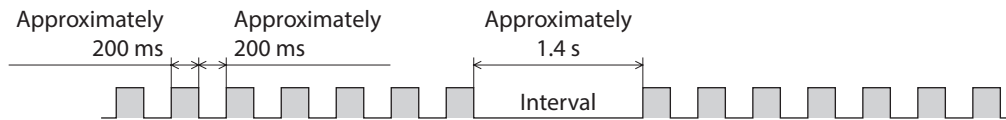

Note If an alarm is generated, the communication between the **NETC01-M2** and RS-485 communication compatible product is stopped. When RS-485 communication is stopped, the parameter command, maintenance command and monitor command of the RS-485 communication compatible product cannot be used.

● Alarm reset

Before resetting an alarm to cycle the power, always remove the cause of the alarm and ensure safety.

Note The alarm in the **NETC01-M2** unit cannot be reset by the **MEXE02**, **OPX-2A** or via MECHATROLINK-II communication.

■ When the MECHATROLINK-II communication error has occurred

If the MECHATROLINK-II communication error has occurred, the ERR LED blinks.
 The motor operation is stopped but RS-485 communication is continued.

How to reset the MECHATROLINK-II communication error

Perform one of the reset operations specified below. Before resetting the MECHATROLINK-II communication error to cycle the power, always remove the cause of the error and ensure safety.

- Execute the alarm reset for the **NETC01-M2** or RS-485 communication compatible product using the **MEXE02** or **OPX-2A**.
- Cycle the power of the **NETC01-M2** or master device.
- Execute the clear alarm or warning command (ALM_CLR: 06h) of MECHATROLINK-II communication.

■ List of alarm and MECHATROLINK-II communication error

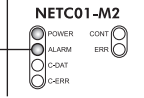
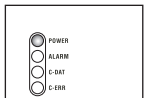
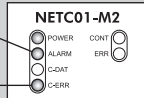
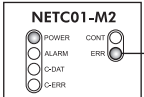
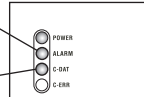
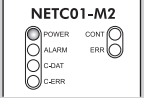
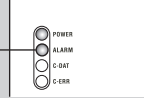
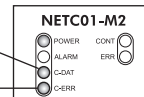
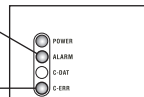
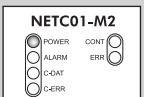
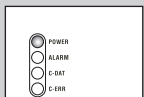
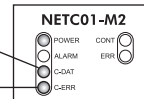
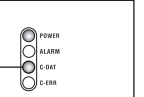
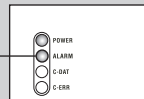
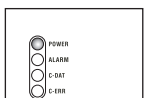
Product	Type	LED status		Alarm code
		NETC01-M2	RS-485 communication compatible product	
NETC01-M2 unit	Alarm	ALARM blinking 9 times 	POWER only lit 	A1h
		ALARM blinking 7 times C-ERR lit red 		E3h
				E4h
				E6h
Between master and NETC01-M2	MECHATROLINK-II communication error		ALARM blinking 7 times C-DAT lit green 	01h
				02h
				03h
Between NETC01-M2 and RS-485 communication compatible product	MECHATROLINK-II communication error	POWER only lit 	ALARM blinking 7 times 	-
		C-DAT lit green C-ERR lit red 	ALARM blinking 7 times C-ERR lit red 	
		POWER only lit 	POWER only lit 	
		C-DAT lit green C-ERR lit red 	C-DAT lit green 	
			ALARM blinking 7 times 	
		POWER only lit 		

Alarm type	System status	Cause	Remedial action
EEPROM error	Communication between the NETC01-M2 and RS-485 communication compatible product cannot be performed.	The stored data of the NETC01-M2 was damaged.	Initialize data using any of the maintenance command, MEXE02 or OPX-2A .
Communication switch setting error		The transmission rate setting switch (SW1) of RS-485 communication was set outside the range (8 and above).	Set the transmission rate setting switch (SW1) to "7."
RS-485 communication error		The RS-485 communication error has been detected three times consecutively.	<ul style="list-style-type: none"> • Check the transmission rate of RS-485 communication. • Check the connector or cable of RS-485 communication.
Network connection product error		The "Communication (address number)" parameter is outside the setting range.	Set either of "0: Disable" or "1: Enable."
Unsupported command	Communication between the NETC01-M2 and master station cannot be performed.	The command that was not implemented was executed.	Re-examine the command sending sequence of the master station.
Command execution condition error		<ul style="list-style-type: none"> • The order (sequence) of the command that has been sent is not correct. • The command not being permitted in the current phase was executed. 	
Outside the range of command data		The data in the command was not correct.	
-	Communication between the NETC01-M2 and RS-485 communication compatible product cannot be performed.	The power supply of the NETC01-M2 was shut off while communicating via RS-485 communication.	Check the power supply of the NETC01-M2 .
		The setting of the SW1 of the NETC01-M2 is not the same as that of the transmission rate of RS-485 communication compatible product.	Check the setting of the switch.
		The "Communication (address number)" parameter is set to "0: Disable."	Set the "Communication (address number)" parameter to "1: Enable."
		The RS-485 communication compatible product corresponding to the "Communication (address number)" parameter does not exist.	Check the address number of the RS-485 communication compatible product.
		The communication of the RS-485 communication compatible product was shut off while communicating.	<ul style="list-style-type: none"> • Check the RS-485 communication cable. • Check the power supply of the RS-485 communication compatible product.
		When the RS-485 communication cable was connected incompletely or it was not connected, the power supply was turned on.	Check the RS-485 communication cable.

10-2 Warning

The present warning can be checked using the **MEXE02** or **OPX-2A**. You can also check the records of up to ten most recent warnings starting from the latest one, or clear the warning records.
 If a warning is generated, the motor will continue to operate. Once the cause of the warning is removed, the warning will be reset automatically.



The warning records can be cleared by turning off the **NETC01-M2** power.

Warning code	Warning type	Cause	Remedial action
E4h	RS-485 communication error	The RS-485 communication error was detected.	<ul style="list-style-type: none"> • Check the transmission rate of RS-485 communication. • Check the connector or cable of RS-485 communication.
E5h	RS-485 communication timeout	Even though the receiving cycle of RS-485 communication has passed, the response frame was not completed receiving.	<ul style="list-style-type: none"> • Check the connector or cable of RS-485 communication. • Check the power supply of the RS-485 communication compatible product.

11 Inspection

It is recommended that periodic inspections for the items listed below are conducted after each operation of the motor. If an abnormal condition is noted, discontinue any use and contact your nearest Oriental Motor sales office.

- Are any of the **NETC01-M2** DIN rail mounting parts loose?
- Are any of the connection parts of the **NETC01-M2** loose?
- Is there attachment of dust, etc., on the **NETC01-M2**?
- Are there any strange smells or appearances within the **NETC01-M2**?



The **NETC01-M2** uses semiconductor elements. Handle the **NETC01-M2** with care since static electricity may damage semiconductor elements. Static electricity may damage the **NETC01-M2**.

12 General specifications

■ Environment specification

	Operation environment	Storage environment Shipping environment
Ambient temperature	0 to +40 °C (+32 to +104 °F) (non-freezing)	-25 to +70 °C (-13 to +158 °F) (non-freezing)
Humidity	85 % or less (non-condensing)	
Altitude	Up to 1,000 m (3,300 ft.) above sea level	Up to 3,000 m (10,000 ft.) above sea level
Surrounding atmosphere	No corrosive gas, dust, water or oil	

■ Insulation specification

Insulation resistance	Between FG terminal and power supply terminals	100 MΩ or more when 500 VDC megger is applied
Dielectric strength		Sufficient to withstand 500 VAC at 50/60 Hz applied for 1 minute, leak current 10 mA or less.

■ RS-485 communication specification

Electrical characteristics	In conformance with EIA-485, straight cable Use a twisted pair cable (TIA/EIA-568B CAT5e or higher is recommended) and keep the total wiring distance including extension to 50 m (164 ft.) or less. *
Communication mode	Half duplex, Asynchronous mode (data: 8 bits, stop bit: 1 bit, parity: none)
Transmission rate	625 kbps
Protocol	Frame size: 10 bytes (fix), binary transmission
Maximum number of connected units	8 units or 16 units (it varies depending on the operation mode.)

* If the motor cable or power supply cable generates an undesirable amount of noise depending on the wiring or configuration, shield the cable or install a ferrite core.

■ MECHATROLINK-II communication specification

Type of Connection	Bus topology
Transmission cable	MECHATROLINK-II dedicated cable (STP cable, impedance 130 Ω) To connect the NETC01-M2 , the dedicated cable with connector is recommended.
Transmission distance	50 m (164 ft.) maximum
Distance between stations	500 mm (19.69 in.) minimum
Baud rate	10 Mbps
Data encoding method	Manchester encoding
Access control method	Master - Device
Electrical insulation between devices and transmission lines	Transformer
Number of stations connected	Up to 30 stations
Station address	60h to 7Fh (Factory setting: 61h)
Communication mode	Cyclic communication mode (Asynchronous command)
Transmission cycle	0.5/1.0/1.5/2.0/2.5/3.0/3.5/4.0/8.0 ms
Data size	17 bytes or 32 bytes (Factory setting: 32 bytes)
Implemented commands	Intelligent I/O command

13 Operation using the OPX-2A

This chapter explains the overview and operation using the **OPX-2A**.

13-1 Overview of the OPX-2A

The **OPX-2A** is a data setter that lets you set parameters and monitor the communication time. In addition, the **OPX-2A** can be used to save the data of **NETC01-M2**. There are four destinations (data banks) to save data.

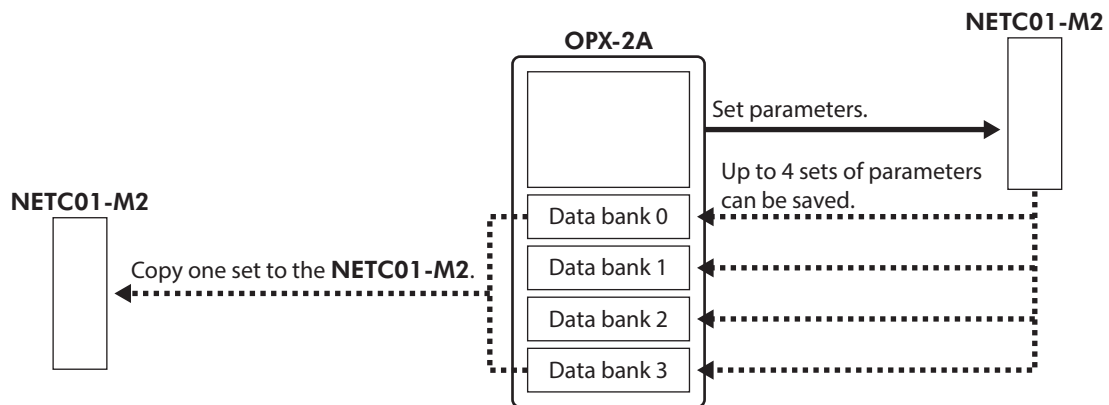

The **OPX-2A** can be used for the following purposes:

- The parameters for the **NETC01-M2** can be set.
- The communication time and status can be monitored.
- The alarm records can be checked and cleared.
- The parameters set in the **NETC01-M2** can be saved to the **OPX-2A**.
- The parameters saved in the **OPX-2A** can be copied to another **NETC01-M2** connected to the **OPX-2A**.

■ Edit lock function

Enable the edit lock function if you want to prevent parameters from being edited or cleared. Parameters cannot be changed or deleted while the edit lock function is enabled.

● Setting the edit lock function

In the top screen of each operation mode, press the $\left[\begin{smallmatrix} \text{MODE} \\ \text{ESC} \end{smallmatrix} \right]$ key for at least 5 seconds.

The display will show "Lock" and the edit lock function will be enabled.

The "LOCK" LED in the LED indicator area will also be lit.

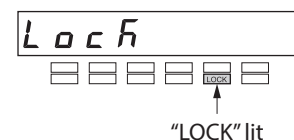

● Canceling the edit lock function

Again in the top screen of each operation mode, press the $\left[\begin{smallmatrix} \text{MODE} \\ \text{ESC} \end{smallmatrix} \right]$ key for at least 5 seconds.

The display will show "UnLock" and the edit lock function will be cancelled.

The "LOCK" LED in the LED indicator area will turn off.

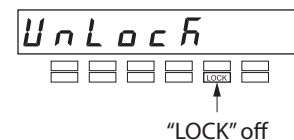

13-2 Names and functions of parts

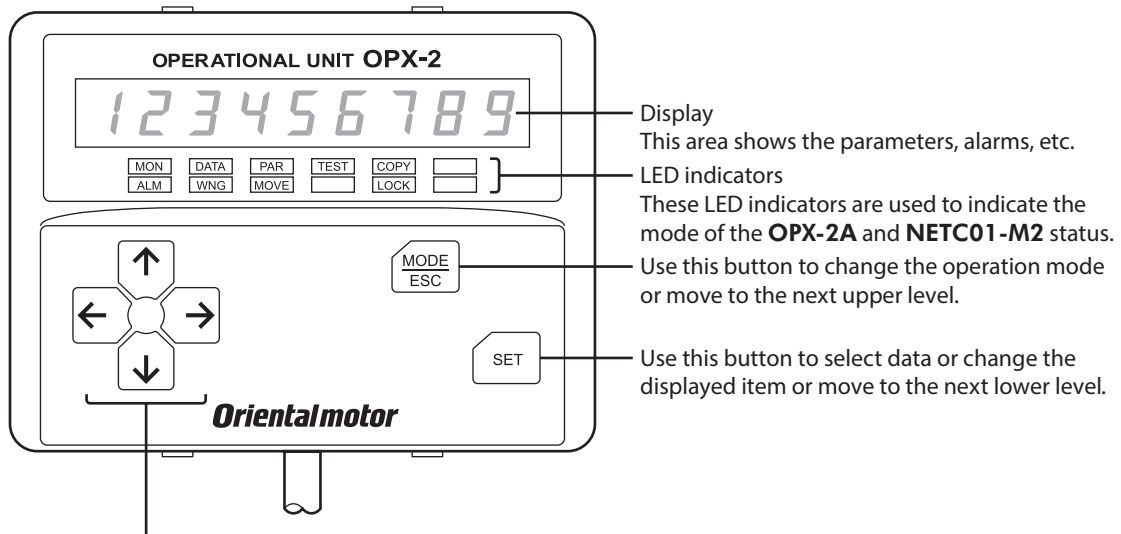

Display
This area shows the parameters, alarms, etc.

LED indicators
These LED indicators are used to indicate the mode of the **OPX-2A** and **NETC01-M2** status.

MODE ESC
Use this button to change the operation mode or move to the next upper level.

SET
Use this button to select data or change the displayed item or move to the next lower level.

Use these buttons to change the selected item or set the parameters.

- Use these buttons to increase or decrease the value or change the selected item.
- Use these buttons to navigate through each data or parameter to a desired digit.

13-3 Notation

In this manual, keys are denoted by symbols, such as $\left[\begin{smallmatrix} \text{MODE} \\ \text{ESC} \end{smallmatrix} \right]$ $\left[\text{SET} \right]$ $\left[\uparrow \right]$ $\left[\downarrow \right]$ $\left[\leftarrow \right]$ $\left[\rightarrow \right]$.
In figures, a simplified illustration of the display and LED indicators is used, as shown below.

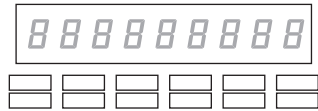

13-4 How to read the display

The display consists of 7-segment LEDs. (The number "5" and alphabet "S" are the same.)

• Numbers

1	1	2	2	3	3	4	4	5	5	6	6	7	7	8	8	9	9	0	0
---	---	---	---	---	---	---	---	---	---	---	---	---	---	---	---	---	---	---	---

• Alphabets

A	A	B	b	C	c	D	d	E	E	F	F	G	G	H	H	I	I	J	J	K	K	L	L
M	n̄	N	n	O	o	P	P	Q	q	R	r	S	S	T	t	U	U	V	v	W	Y	Y	Y

• Signs

+	+	-	-
---	---	---	---

■ **How to read the LED indicators**

When the operation mode is changed or an alarm or warning generates, a corresponding LED will be lit. While the edit lock function is enabled, the condition is also indicated by the illumination of a corresponding LED.

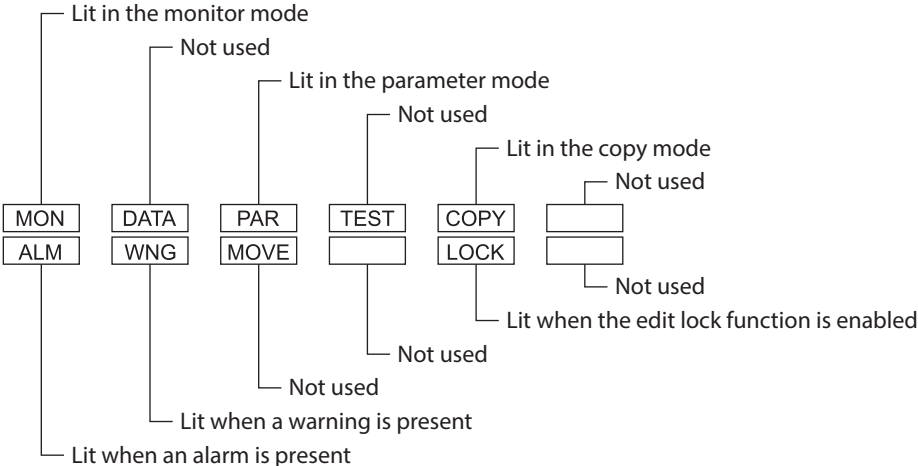

13-5 OPX-2A error display

Errors displayed on the **OPX-2A** are explained.

Error display	Meaning	Action
	A communication error occurred between the OPX-2A and NETC01-M2 .	<ul style="list-style-type: none"> • Check if the OPX-2A is connected securely. • Check if the OPX-2A cable is disconnected or damaged. • The OPX-2A or the communication part of the NETC01-M2 may have damaged. Contact your nearest Oriental Motor sales office.

13-6 Screen transitions

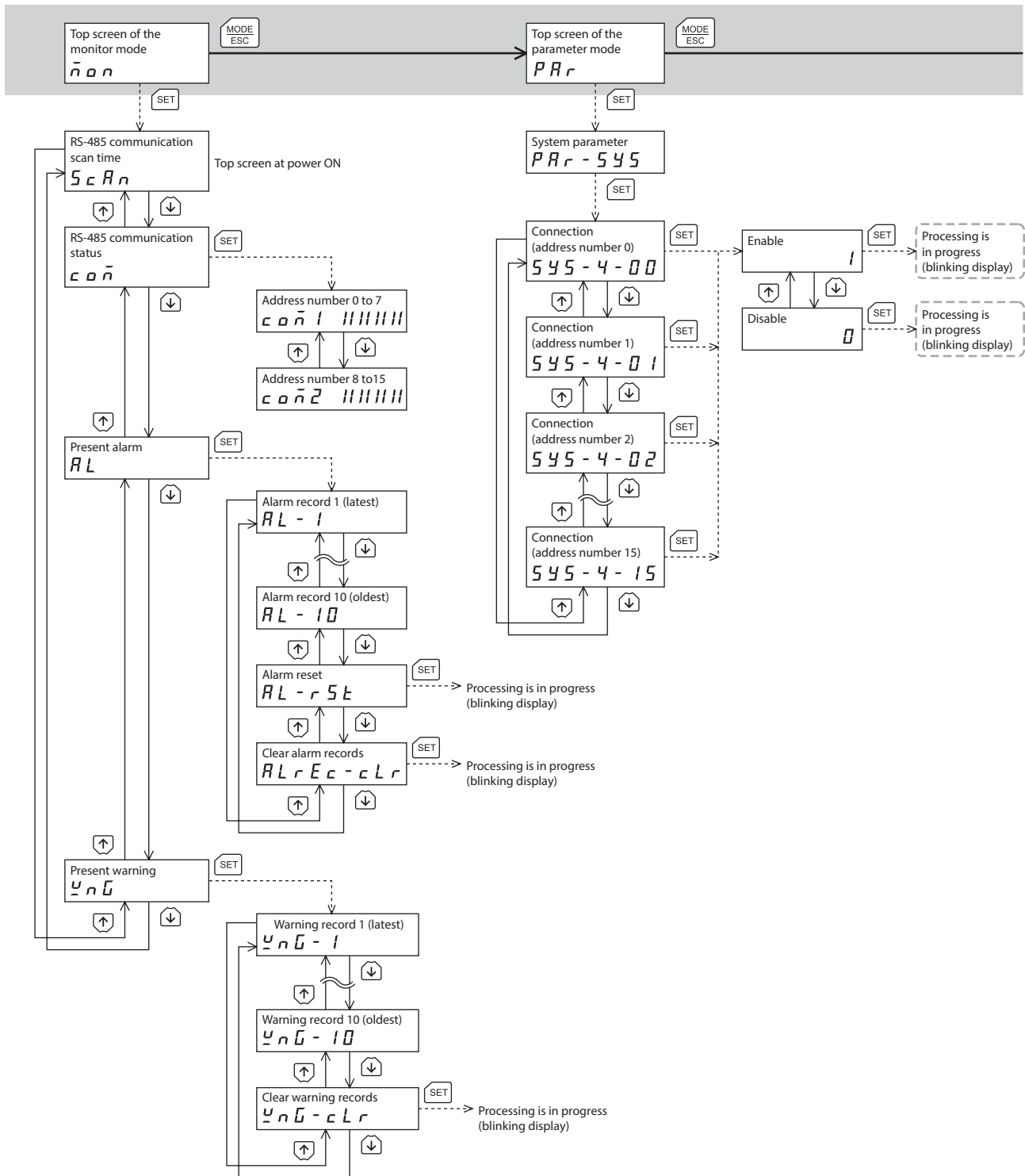

Note

- For the parameter mode and copy mode, if the [SET] key is pressed while processing the memory of the **NETC01-M2** via MECHATROLINK-II communication, the screen cannot move to the lower level from the top screen and "mEm-busy" is displayed. Be sure to wait until the memory processing is completed, before pressing the [SET] key.
- The following limitations are present while the edit lock function is enabled.
 - Parameter mode, copy mode: Although they are displayed on the screen, they are unable to operate.
 - Clearing the alarm and warning records: They are not displayed on the screen.

13-7 Monitor mode

■ Overview of the monitor mode

● Monitoring the communication status

The communication scan time and communication status can be monitored.

● Checking alarms/warnings, clearing alarm/warning records, and resetting alarms

- If an alarm or warning generates, a corresponding alarm code or warning code will be displayed. You can check the code to identify the details of the alarm/warning.
- Up to ten most recent alarms/warnings can be displayed, starting from the latest one.
- The present alarm can be reset.
- Alarm/warning records can be cleared.

■ Monitor items

● RS-485 communication scan time

The communication time between the **NETC01-M2** and connected product can be monitored in real time (unit: msec).

● RS-485 communication status

The communication status of the connected product can be checked.

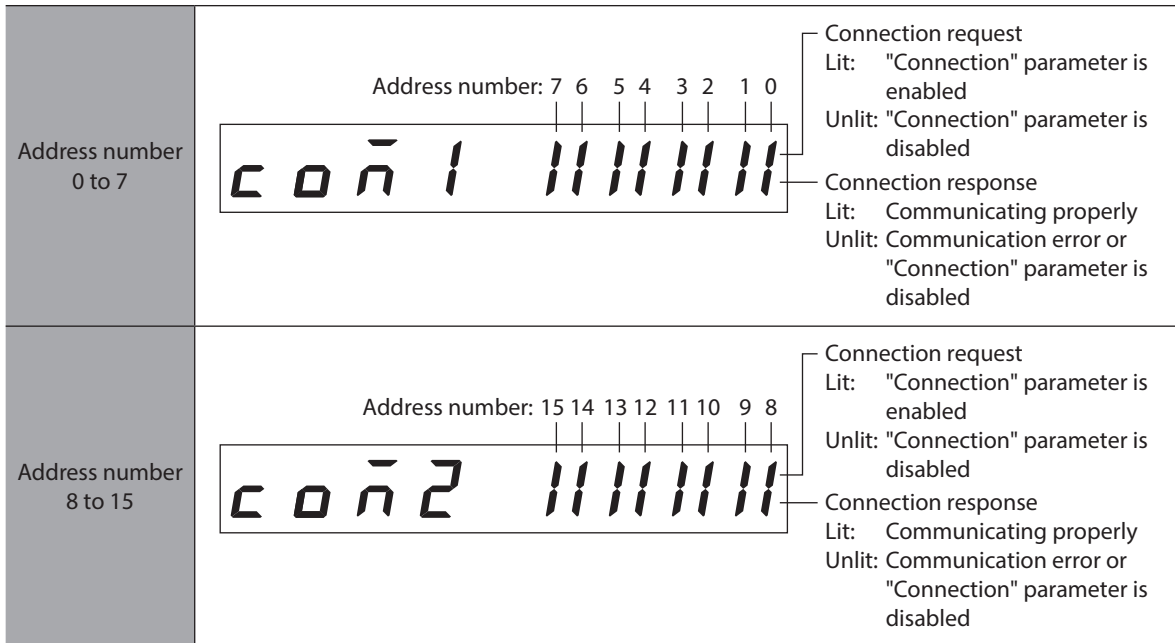

● Present alarm

When an alarm generates, a corresponding alarm code will be displayed. Also, alarm records can be checked and cleared.

Alarm code list

No. of ALARM LED blinks	Alarm code	Alarm type
9	A1h	EEPROM error
7	E3h	Communication switch setting error
	E4h	RS-485 communication error
	E6h	Network connection product error

Note

- Do not turn off the **NETC01-M2** power while alarm records are being cleared (=while the display is blinking). Doing so may damage the data.
- If an alarm generates, communication between the **NETC01-M2** and RS-485 communication compatible product is stopped. The remote I/O, parameter command, maintenance command and monitor command of the RS-485 communication compatible product cannot be used.
- To reset the alarms, cycle the **NETC01-M2** power.

● Present warning

When a warning generates, a corresponding warning code will be displayed. Warning records can be checked and cleared.

Warning code list

Warning code	Warning type
E4h	RS-485 communication error
E5h	RS-485 communication timeout

Note

- Do not turn off the **NETC01-M2** power while a warning records are being cleared (=while the display is blinking). Doing so may damage the data.
- Warning records can be cleared automatically by turning off the **NETC01-M2** power.

13-8 Parameter mode

When a parameter is changed, the new parameter will be updated after the **NETC01-M2** power is turned on again.

■ Application parameter

Parameter name	Description	Setting range	Initial value	OPX-2A screen display
Data setter edit	Sets whether it is possible to edit using the OPX-2A .	0: Disable 1: Enable	1: Enable	— *

* It can be changed by setting/canceling the edit lock function on the **OPX-2A**.

■ System parameter

Parameter name	Description	Setting range	Initial value	OPX-2A screen display
Connection (address number 0)	Sets whether to enable or disable the communication with the connected product.	0: Disable 1: Enable	0: Disable	SYS-4-00
Connection (address number 1)				SYS-4-01
Connection (address number 2)				SYS-4-02
Connection (address number 3)				SYS-4-03
Connection (address number 4)				SYS-4-04
Connection (address number 5)				SYS-4-05
Connection (address number 6)				SYS-4-06
Connection (address number 7)				SYS-4-07
Connection (address number 8)				SYS-4-08
Connection (address number 9)				SYS-4-09
Connection (address number 10)				SYS-4-10
Connection (address number 11)				SYS-4-11
Connection (address number 12)				SYS-4-12
Connection (address number 13)				SYS-4-13
Connection (address number 14)				SYS-4-14
Connection (address number 15)				SYS-4-15



- If operations are limited by the edit lock function (p.45), parameters cannot be edited.
- The non-volatile memory can be rewritten approx. 100,000 times.

13-9 Copy mode

■ Download

Parameters saved in the **OPX-2A** can be copied to the **NETC01-M2**.

If a download error occurs, a code indicating the description of the error will blink on the display. Download will not be performed and the display will return to the top screen of download. Refer to "Error of the copy mode" on p.53 for the error display.

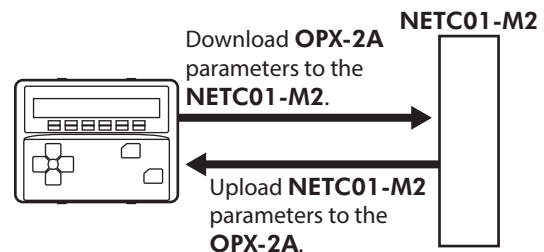

■ Upload

Parameters saved in the **NETC01-M2** can be copied to the **OPX-2A**.

■ Verification

Parameters in the **OPX-2A** can be verified against the corresponding parameters in the **NETC01-M2**.

If the verification finds that the two sets of parameter match, "Good" will be shown. If the two do not match, "Error" will be shown.

If a verification error occurs, a code indicating the description of the error will blink on the display. Verification will not be performed and the display will return to the top screen of verification.

Refer to "Error of the copy mode" on p.53 for the error display.

■ Initializing parameters

Parameters saved in the **NETC01-M2** can be restored to the initial values.

■ What happens when the [SET] key is pressed while the edit lock function is enabled

While the edit lock function is enabled, you cannot move to any lower level from the top screen of the copy mode. Pressing the [SET] key will generate an error, and "Lock-Err" will be shown.

L o c k - E r r

Be sure to cancel the edit lock function before pressing the [SET] key. Refer to p.45 for the procedure to cancel the edit lock function.

Note

- If the [SET] key is pressed while processing the memory of the **NETC01-M2** via MECHATROLINK-II communication, the screen cannot move to the lower level from the top screen and "mEm-busy" is displayed. Be sure to wait until the memory processing is completed, before pressing the [SET] key.
- When a system parameter is changed, the new parameter will be updated after the power is turned on again. When system parameters were changed by downloading, turn on the **NETC01-M2** power again.
- Do not turn off the **NETC01-M2** power while the download is still in progress (=while the display is blinking). Doing so may damage the data.

■ Error of the copy mode

If an error occurs in download or verification, the error code will blink on the display.

At this time, the processing will not be executed and the display will return to the top screen.

Blinking display	Description	Action
P r o d - E r r	There is a discrepancy between the selected product series and the data being processed.	<ul style="list-style-type: none"> • Check the product series. • Check the data bank number on the OPX-2A.
H E A D - E r r b c c - E r r	An error occurred while processing.	Execute the processing again. If the same error occurs, the parameters saved in the OPX-2A may have damaged. Upload and set the parameters of the OPX-2A again.
n o - d A t A	The specified data bank number does not contain data.	Check the data bank number.
d A t A - E r r	An error occurred while parameter was being downloaded.	Perform download again.

14 Accessories

■ Data setter

The data setter lets you set parameters for your **NETC01-M2** with ease and monitor the communication time.

Model: **OPX-2A**

■ Communication cable for the support software

Be sure to purchase the communication cable for the support software when connecting the **NETC01-M2** to the PC in which the support software **MEXE02** has been installed.

This is a set of a PC interface cable and USB cable. The cable is connected to the USB port on the PC.

Model: **CC05IF-USB** [5 m (16.4 ft.)]

The **MEXE02** can be downloaded from Oriental Motor Website Download Page. For details, check out our Website or contact your nearest Oriental Motor sales office.

■ RS-485 communication cable

The RS-485 communication compatible product can be connected.

Model: **CC001-RS4** [0.1 m (0.3 ft.)]

CC002-RS4 [0.25 m (0.8 ft.)]

- Unauthorized reproduction or copying of all or part of this manual is prohibited.
If a new copy is required to replace an original manual that has been damaged or lost, please contact your nearest Oriental Motor sales office.
- Oriental Motor shall not be liable whatsoever for any problems relating to industrial property rights arising from use of any information, circuit, equipment or device provided or referenced in this manual.
- Characteristics, specifications and dimensions are subject to change without notice.
- While we make every effort to offer accurate information in the manual, we welcome your input. Should you find unclear descriptions, errors or omissions, please contact your nearest Oriental Motor sales office.
- **Orientalmotor** is a registered trademark or trademark of Oriental Motor Co., Ltd., in Japan and other countries.
MECHATROLINK is a registered trademark of the MECHATROLINK Members Association.
Other product names and company names mentioned in this manual may be registered trademarks or trademarks of their respective companies and are hereby acknowledged. The third-party products mentioned in this manual are recommended products, and references to their names shall not be construed as any form of performance guarantee. Oriental Motor is not liable whatsoever for the performance of these third-party products.

© Copyright ORIENTAL MOTOR CO., LTD. 2013

Published in August 2025

- Please contact your nearest Oriental Motor office for further information.

ORIENTAL MOTOR U.S.A. CORP.
Technical Support Tel:800-468-3982
8:30am EST to 5:00pm PST (M-F)

ORIENTAL MOTOR (EUROPA) GmbH
Schiessstraße 44, 40549 Düsseldorf, Germany
Technical Support Tel:00 800/22 55 66 22

ORIENTAL MOTOR (UK) LTD.
Blythe Valley Business Park,
Central Blvd Blythe Valley Park,
Solihull B90 8AG, United Kingdom
Tel:+44-1926-671220

ORIENTAL MOTOR (FRANCE) SARL
Tel:+33-1 47 86 97 50

ORIENTAL MOTOR ITALIA s.r.l.
Tel:+39-02-93906347

ORIENTAL MOTOR ASIA PACIFIC PTE. LTD.
Singapore
Tel:1800-842-0280

ORIENTAL MOTOR (MALAYSIA) SDN. BHD.
Tel:1800-806-161

ORIENTAL MOTOR (THAILAND) CO., LTD.
Tel:1800-888-881

ORIENTAL MOTOR (INDIA) PVT. LTD.
Tel:1800-120-1995 (For English)
1800-121-4149 (For Hindi)

TAIWAN ORIENTAL MOTOR CO., LTD.
Tel:0800-060708

SHANGHAI ORIENTAL MOTOR CO., LTD.
Tel:400-820-6516

INA ORIENTAL MOTOR CO., LTD.
Korea
Tel:080-777-2042

ORIENTAL MOTOR CO., LTD.
4-8-1 Higashiueno, Taito-ku, Tokyo
110-8536 Japan
Tel:+81-3-6744-0361
www.orientalmotor.co.jp/ja