



## OPERATING MANUAL

For 2-phase, 5-phase Stepping Motors

**CVD Driver**



MSIP-REM-OMC-075  
MSIP-REM-OMC-076

### Introduction

#### ● Before use

Only qualified personnel should work with the product. Use the product correctly after thoroughly reading the "Safety precautions." The product described in this manual has been designed and manufactured to be incorporated in general industrial equipment. Do not use for any other purpose. Oriental Motor Co., Ltd. is not responsible for any damage caused through failure to observe this warning.

#### ● Overview of the product

This product is a board type microstepping driver equipped the smooth drive function.

#### ● Hazardous substances

The products do not contain the substances exceeding the restriction values of RoHS Directive (2011/65/EU).

### Safety precautions

The precautions described below are intended to prevent danger or injury to the user and other personnel through safe, correct use of the product. Use the product only after carefully reading and fully understanding these instructions.

#### Description of signs

	Handling the product without observing the instructions that accompany a "Warning" symbol may result in serious injury or death.
	Handling the product without observing the instructions that accompany a "Caution" symbol may result in injury or property damage.

#### Description of graphic symbols

	Indicates "prohibited" actions that must not be performed.
	Indicates "compulsory" actions that must be performed.

### Warning

	<ul style="list-style-type: none"> <li>Do not use the product in explosive or corrosive environments, in the presence of flammable gases, locations subjected to splashing water, or near combustibles. This may cause fire or injury.</li> <li>Do not forcibly bend, pull or pinch the cable. This may cause fire.</li> <li>Do not turn the AWO input to ON while the motor is operating. This may cause injury or damage to equipment.</li> <li>Do not disassemble or modify the product. This may cause injury.</li> </ul>
--	---

Thank you for purchasing an Oriental Motor product. This Manual describes product handling procedures and safety precautions.

- Please read it thoroughly to ensure safe operation.
- Always keep the manual where it is readily available.

### Warning

	<ul style="list-style-type: none"> <li>Assign qualified personnel the task of installing, wiring, operating/controlling, inspecting and troubleshooting the product. Failure to do so may result in fire or injury.</li> <li>If this product is used in a vertical application, be sure to provide a measure for the position retention of moving parts. Failure to do so may result in injury or damage to equipment.</li> <li>When the driver generates an alarm (any of the driver's protective functions is triggered), first remove the cause and then clear the protection function. Continuing the operation without removing the cause of the problem may cause malfunction of the driver, leading to injury or damage to equipment.</li> <li>Install the product in an enclosure. Failure to do so may result in injury.</li> <li>Keep the driver's input-power voltage within the specified range. Failure to do so may result in fire.</li> <li>For the driver power supply use a DC power supply with reinforced insulation on its primary and secondary sides. Failure to do so may result in electric shock.</li> <li>Connect the cables securely according to the wiring diagram. Failure to do so may result in fire.</li> <li>Turn off the driver power in the event of a power failure. Failure to do so may result in injury or damage to equipment.</li> </ul>
--	--

### Caution

	<ul style="list-style-type: none"> <li>Do not use the product beyond its specifications. This may cause injury or damage to equipment.</li> <li>Keep your fingers and objects out of the openings in the product. Failure to do so may result in fire or injury.</li> <li>Do not touch the product while operating or immediately after stopping. This may cause a skin burn(s).</li> <li>Do not forcibly bend or pull the cable that was connected to the driver. Doing so may cause damage.</li> <li>Keep the area around the product free of combustible materials. Failure to do so may result in fire or a skin burn(s).</li> <li>Leave nothing around the product that would obstruct ventilation. Failure to do so may result in damage to equipment.</li> <li>Do not touch the rotating part (output shaft) while operating the motor. Doing so may result in injury.</li> </ul>
	<ul style="list-style-type: none"> <li>Use a motor and driver only in the specified combination. Failure to do so may result in fire.</li> <li>Provide an emergency stop device or emergency stop circuit so that the entire equipment will operate safely in the event of a system failure or malfunction. Failure to do so may result in injury.</li> <li>Before supplying power to the driver, turn all input signals to the driver to OFF. Failure to do so may result in injury or damage to equipment.</li> </ul>

## ⚠ Caution



- Before moving the motor directly with the hands, confirm that the AWO input turns ON.  
Failure to do so may result in injury.
- When an abnormal condition has occurred, immediately stop operation and turn off the driver power.  
Failure to do so may result in fire or injury.
- To dispose of the product, disassemble it into parts and components as much as possible and dispose of individual parts/components as industrial waste.

## Precautions for use

### • Conduct the insulation resistance test or dielectric strength test separately on the motor and the driver.

Conducting the insulation resistance test or dielectric strength test with the motor and driver connected may result in damage to the product.

### • Regeneration

When a large inertial load is operated at high speed, regeneration energy will generate and increase the power supply voltage, which may damage the driver. Check the operating condition so that regeneration voltage will not generate.

## Specifications

Operation environment	Ambient temperature	0 to +50 °C (+32 to +122 °F) (non-freezing)
	Humidity	85% or less (non-condensing)
	Altitude	Up to 1000 m (3300 ft.) above sea level
	Surrounding atmosphere	No corrosive gas, dust, water or oil
Storage environment, Shipping environment	Ambient temperature	-25 to +70 °C (-13 to +158 °F) (non-freezing)
	Humidity	85% or less (non-condensing)
	Altitude	Up to 3000 m (10000 ft.) above sea level
	Surrounding atmosphere	No corrosive gas, dust, water or oil

## Regulations and standards

### ■ CE Marking

#### ● Low Voltage Directives

Although this product is exempt from the Low Voltage Directive since the input power supply voltage is 24 VDC, perform the installation and connection as follows.

- This product is designed and manufactured to be incorporated in equipment. Be sure to install the product in an enclosure.
- For the driver power supply, use a DC power supply with reinforced insulation on its primary and secondary sides.

#### ● EMC Directive

This product has received EMC compliance under the conditions specified in "Example of motor and driver installation and wiring" on p.9. The conformance of your mechanical equipment to the EMC Directive will vary depending on such factors as the control system equipment used with this product, configuration of electrical parts, wiring and layout. It therefore must be verified through conducting EMC measures in a state that all parts including this product have been installed in the equipment.

#### Applicable Standards

EMI	EN 55011 group 1 class A, EN 61000-6-4
EMS	EN 61000-6-2

## ■ Republic of Korea, Radio Waves Act

Seller and user shall be noticed that this equipment is suitable for electromagnetic equipments for office work (Class A) and it can be used outside home.

이 기기는 업무용 (A급) 전자파적합기기로서 판매자 또는 사용자는 이 점을 주의하시기 바라며, 가정외의 지역에서 사용하는 것을 목적으로 합니다.

## Preparation

### ■ Checking the product

Verify that the items listed below are included. Report any missing or damaged items to the branch or sales office from which you purchased the product.

- Driver ..... 1 unit
- OPERATING MANUAL ..... 1 copy (this document)
- Connector housing/contact ..... 1 set  
(packed in a bag; See table next.)

#### • CVD242BR-K, CVD245BR-K, CVD528BR-K

Application	Housing (Molex)	Contact (Molex)
For power supply (CN1)	1 pc. 51067-0200 (2-poles)	2pcs. 50217-9101
For motor (CN2)	1 pc. 51067-0500 (5-poles)	5pcs. 50217-9101
For I/O signals (CN3)	1 pc. 51103-1200 (12-poles)	12pcs. 50351-8100

#### • For drivers other than above driver models

Application	Housing (Molex)	Contact (Molex)
For power supply (CN1)	1 pc. 51103-0200 (2-poles)	19 pcs. 50351-8100
For motor (CN2)	1 pc. 51103-0500 (5-poles)	
For I/O signals (CN3)	1 pc. 51103-1200 (12-poles)	



When removing the driver from the ESD protection bag, make sure your hands are not charged with static electricity. This is to prevent damage to the driver due to static electricity.

### ■ Possible combinations for motor specification

Specifications of the motor with which the CVD driver can be combined are listed below.

#### ● 2-Phase Motor

Drive type	Driver model	Motor rated current	Regulations
Driver without mounting plate	CVD205-K	0.5 A/ Phase	CE, KC
	CVD206-K	0.6 A/ Phase	-
	CVD215-K	1.5 A/ Phase	CE, KC
	CVD223-K	2.3 A/ Phase	CE, KC
	CVD228-K	2.8 A/ Phase	CE, KC
Driver with mounting plate	CVD205BR-K	0.5 A/ Phase	CE, KC
	CVD215BR-K	1.5 A/ Phase	CE, KC
	CVD223BR-K	2.3 A/ Phase	CE, KC
	CVD228BR-K	2.8 A/ Phase	CE, KC
	CVD242BR-K	4.2 A/ Phase	-
	CVD245BR-K	4.5 A/ Phase	-

## ● 5-Phase Motor

Drive type	Driver model	Motor rated current	Regulations
Driver without mounting plate	CVD503-K	0.35 A/ Phase	-
	CVD507-K	0.75 A/ Phase	-
	CVD512-K	1.2 A/ Phase	CE, KC
	CVD514-K	1.4 A/ Phase	-
	CVD518-K	1.8 A/ Phase	CE, KC
	CVD524-K	2.4 A/ Phase	CE, KC
Driver with mounting plate	CVD512BR-K	1.2 A/ Phase	CE, KC
	CVD518BR-K	1.8 A/ Phase	CE, KC
	CVD524BR-K	2.4 A/ Phase	CE, KC
	CVD528BR-K	2.8 A/ Phase	-

## ■ Names of parts

### ● Driver without mounting plate

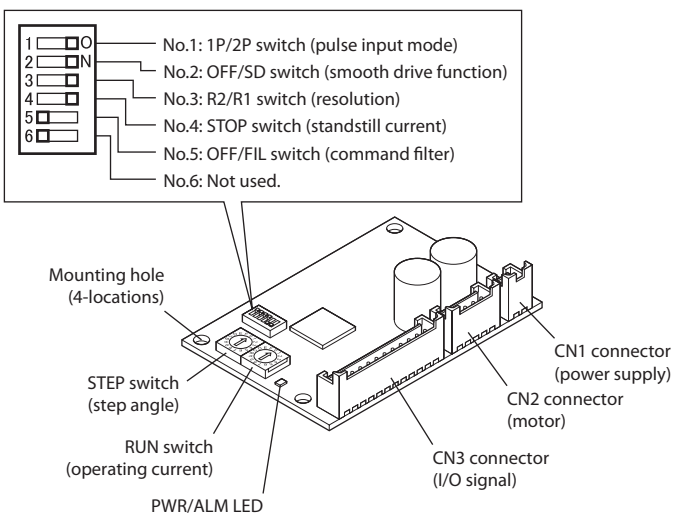

### ● Driver with mounting plate

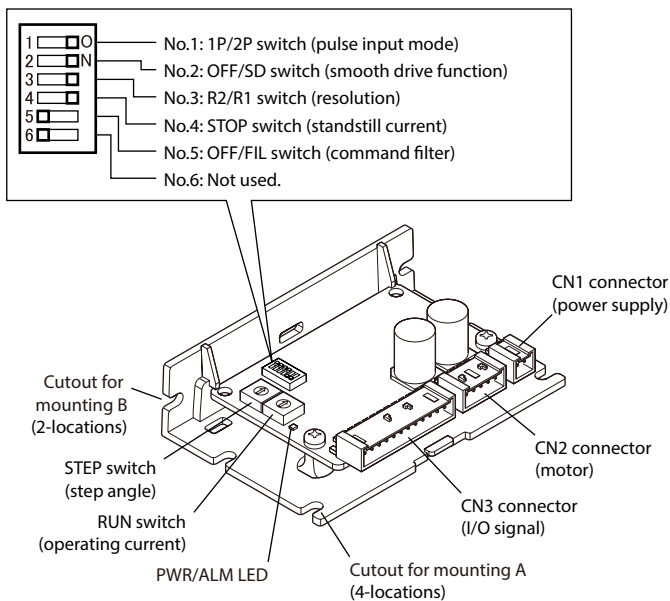

## Installation

### ■ Location for installation

The driver has been designed and manufactured to be incorporated in equipment. Install it in a well-ventilated location that provides easy access for inspection.

The location must also satisfy the following conditions:

- Inside an enclosure that is installed indoors (provide vent holes)
- Operating ambient temperature 0 to +50 °C (+32 to +122 °F) (non-freezing)
- Operating ambient humidity 85% or less (non-condensing)
- Area that is free of explosive atmosphere or toxic gas (such as sulfuric gas) or liquid
- Area not exposed to direct sun
- Area free of excessive amount of dust, iron particles or the like
- Area not subject to splashing water (rain, water droplets), oil (oil droplets) or other liquids
- Area free of excessive salt
- Area not subject to continuous vibration or excessive shocks
- Area free of excessive electromagnetic noise (from welders, power machinery, etc.)
- Area free of radioactive materials, magnetic fields or vacuum
- 1000 m (3300 ft.) or lower above sea level

### ■ Installation method

Install the driver on a metal plate having excellent vibration resistance in vertically or horizontally. If the driver is installed under conditions other than vertical or horizontal position, its heat radiation effect will deteriorate.

The items shown below are necessary in order to install the driver. The items are not included and must be provided by the customer.

Torque the mounting screw to 0.5 N·m (71 oz-in).

Driver type	Driver without mounting plate	Driver with mounting plate
M3 screw	4 pcs.	4 pcs. (2 pcs.) *
M3 spring washer	4 pcs.	4 pcs. (2 pcs.) *
M3 nut (Not necessary if screw holes are provided in the enclosure.)	4 pcs.	4 pcs. (2 pcs.) *
Spacer [5 mm (0.2 in.) or larger]	4 pcs.	-

\* ( ): When using the cutout for mounting B.

There must be a clearance of at least 25 mm (0.98 in.) in the horizontal and 50 mm (1.97 in.) in the vertical directions, between the driver and enclosure or other equipment within the enclosure. When two or more drivers are to be installed side by side, provide 20 mm (0.79 in.) and 50 mm (1.97 in.) clearances in the horizontal and vertical directions, respectively.



- Install the driver in an enclosure.
- Do not install any equipment that generates a large amount of heat or noise near the driver.
- If the ambient temperature of the driver exceeds 50 °C (122 °F), improve the ventilation condition.

● Driver without mounting plate

• Horizontal installation

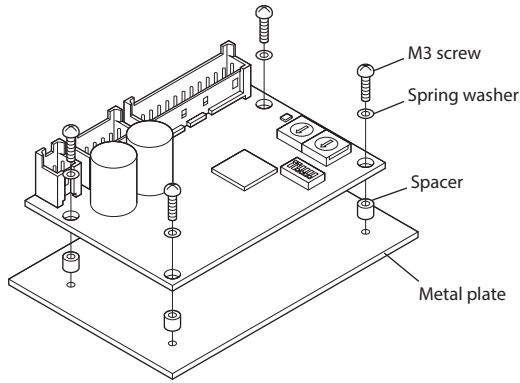

• Vertical installation

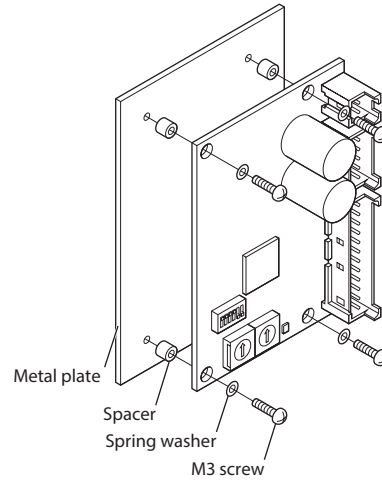

● Driver with mounting plate

• Horizontal installation

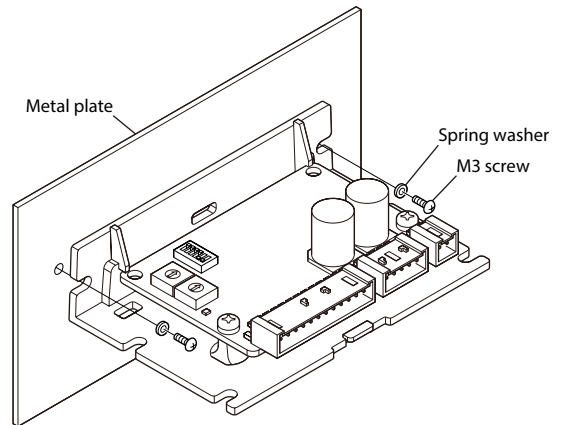
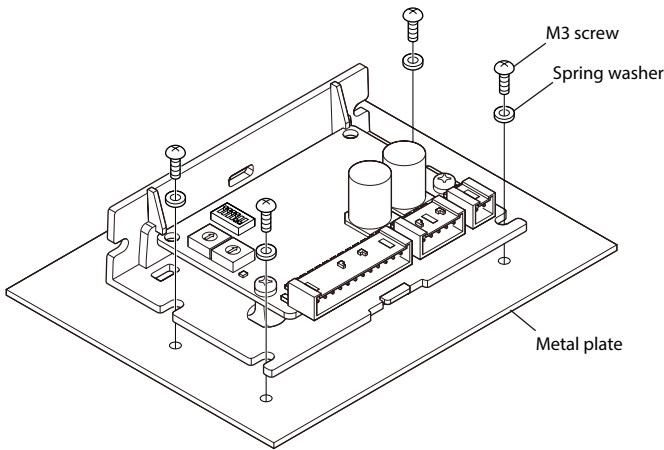

• Vertical installation

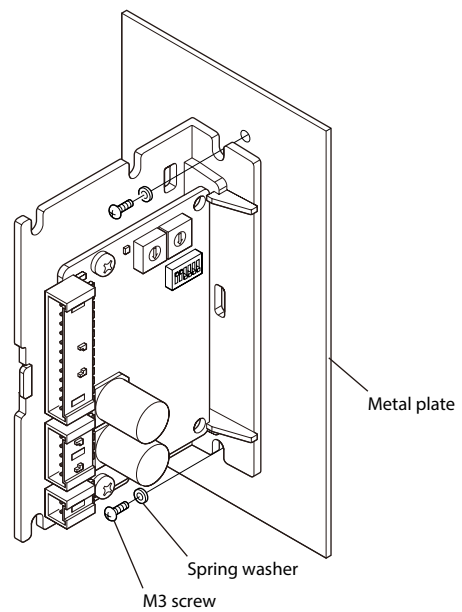
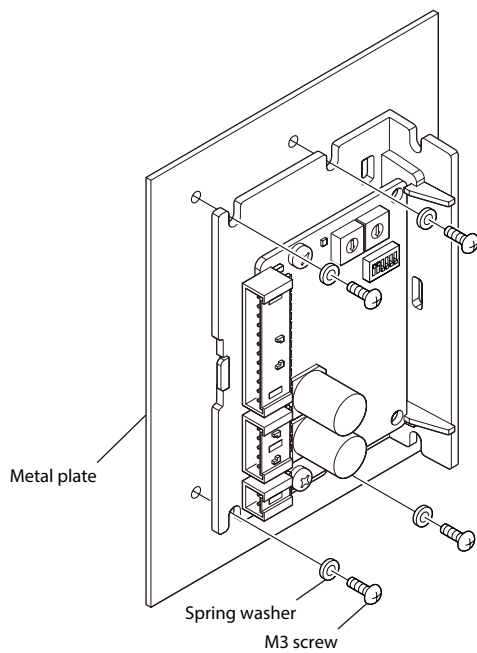

Install the driver using either of the "cutout for mounting A" or "cutout for mounting B." Do not concurrently use both cutouts.

# Connection

## ■ Connection example

### ● When pulse input is of line driver type

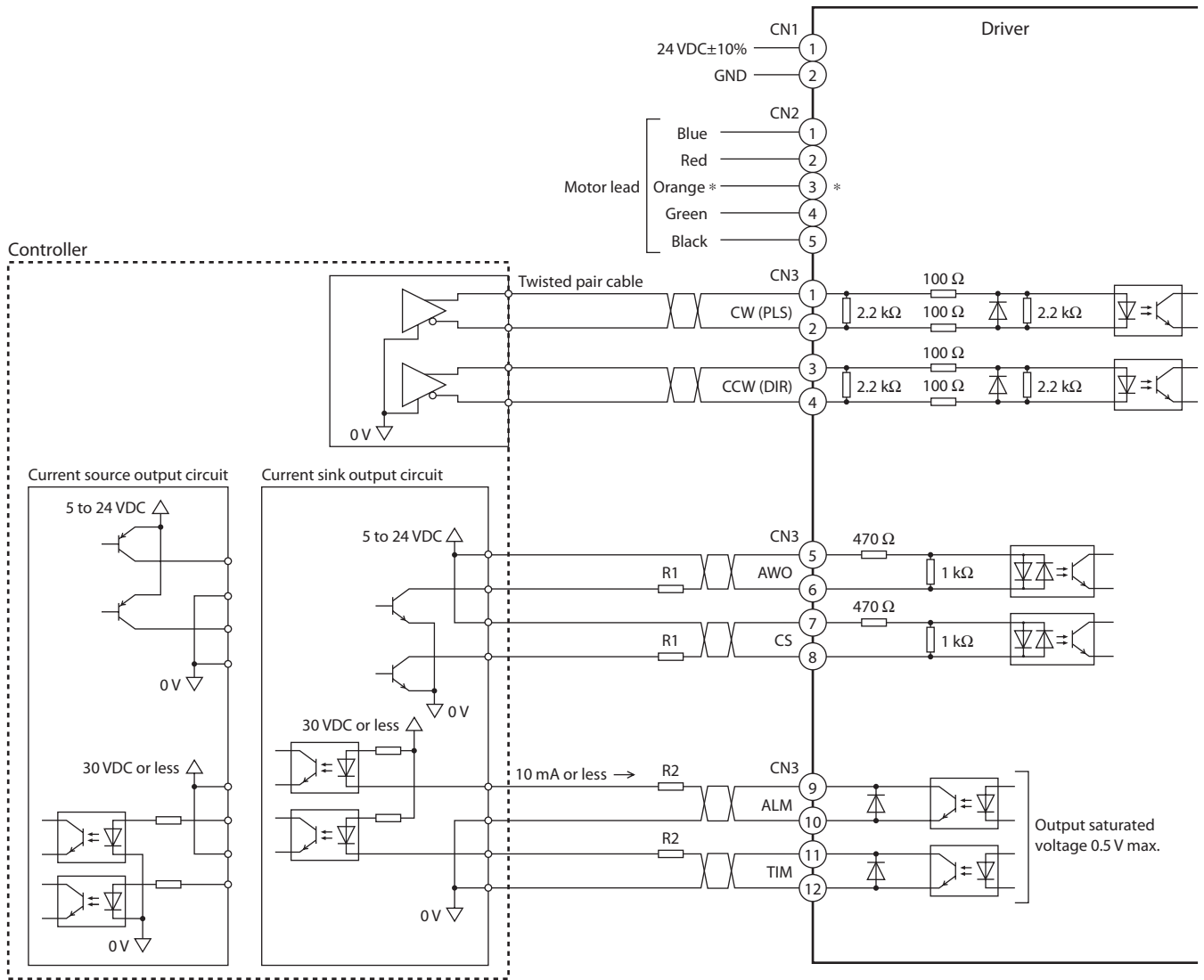

\* This orange lead wire is for 5-phase stepping motor. For 2-phase stepping motor, do not connect anything to the pin No.3 since there is no orange lead wire.



- Use input signals at 5 VDC. If the voltage exceeding 5 VDC is applied, connect an external resistor R1 so that the input current becomes 5 to 15 mA.
- Use output signals at 30 VDC, 10 mA or less. If the current exceeds 10 mA, connect an external resistor R2 so that the current becomes 10 mA or less.

### ● When pulse input is of open-collector type

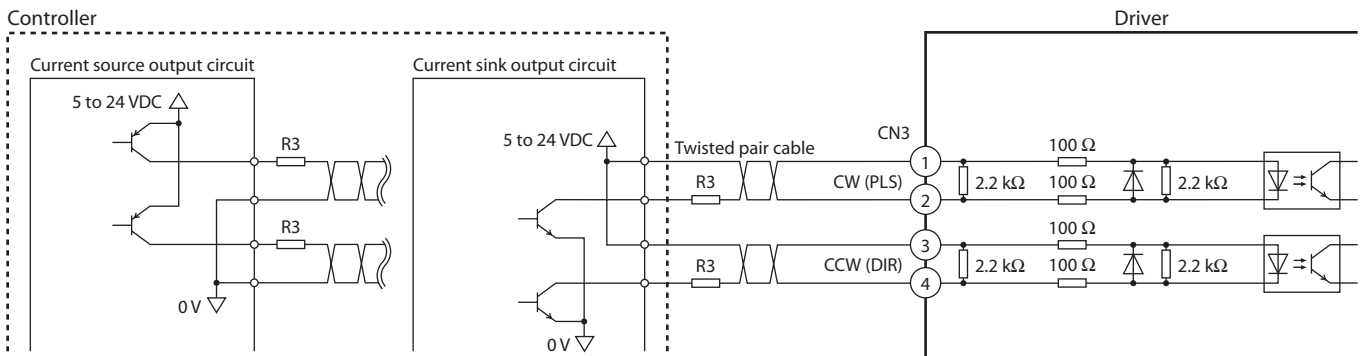

Use the CW input and CCW input at 5 VDC. If the voltage exceeding 5 VDC is applied, connect an external resistor R3 so that the input current becomes 7 to 20 mA.

## ■ Connector pin assignment

### ● CN1 (power supply)

Pin No.	Direction	Signal name	Description
1	IN	POWER	+
2			-
			+24 VDC
			GND

### ● CN2 (motor)

Pin No.	Direction	Signal name	Description
1	OUT	MOTOR	Blue motor lead
2			Red motor lead
3			Orange motor lead *
4			Green motor lead
5			Black motor lead

\* This orange lead wire is for 5-phase stepping motor. For 2-phase stepping motor, do not connect anything to the pin No.3 since there is no orange lead wire.

### ● CN3 (I/O signals)

Pin No.	Direction	Signal name	Description
1	IN	CW (PLS)	+
2			-
3		CCW (DIR)	+
4			-
5		AWO	+
6			-
7	CS	+	
8		-	
9	OUT	ALM	+
10			-
11		TIM	+
12	-		

\* These inputs serve as the CW pulse input (CW) and CCW pulse input (CCW) in the 2-pulse input mode, or pulse input (PLS) and rotation direction input (DIR) in the 1-pulse input mode.

## ■ Applicable connector

- CVD242BR-K, CVD245BR-K, CVD528BR-K

Type	Application	Model
Connector housing	For power supply (CN1)	51067-0200 (Molex)
	For motor (CN2)	51067-0500 (Molex)
	For I/O signals (CN3)	51103-1200 (Molex)
Contact	For power supply (CN1)	50217-9101 (Molex)
	For motor (CN2)	50351-8100 (Molex)
	For I/O signals (CN3)	50351-8100 (Molex)
Applicable crimping tool	For power supply (CN1)	57189-5000 (Molex)
	For motor (CN2)	57189-5000 (Molex)
	For I/O signals (CN3)	63811-8100 (Molex)

### ● For drivers other than above driver models

Type	Application	Model
Connector housing	For power supply (CN1)	51103-0200 (Molex)
	For motor (CN2)	51103-0500 (Molex)
	For I/O signals (CN3)	51103-1200 (Molex)
Contact	-	50351-8100 (Molex)
Applicable crimping tool	-	63811-8100 (Molex)

- For the power supply cable, use a cable of AWG22 (0.3 mm<sup>2</sup>). However, for the CVD242BR-K, CVD245BR-K, and CVD528BR-K, use a cable of AWG20 (0.5 mm<sup>2</sup>).
- For the I/O signals cable, use a twisted pair cable of AWG24 to 22 (0.2 to 0.3 mm<sup>2</sup>).
- Keep the wiring distance as short as possible [less than 2 m (6.6 ft.)] to suppress the effect of noise.

### Note

For the motor of the frame size 20 mm (0.79 in.) [PKP213 type], since the wire diameter of the motor cable is AWG26, it is too thin to fit in the supplied connector for motor. Provide the AWG24 (0.2 mm<sup>2</sup>) or thicker cable yourself, and connect by using it.

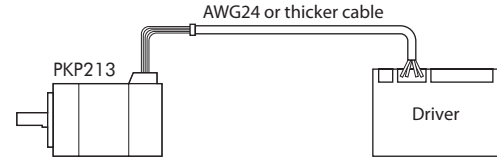

## ■ Connecting the power supply

Use a power supply that can supply the following current capacity. When the power is turned on, the PWR/ALM LED will be lit in green.

### ● 2-Phase Motor

Driver model	Input power supply voltage	Power supply current capacity
CVD205	+24 VDC±10%	0.5 A or more
CVD206		0.5 A or more
CVD215		1.3 A or more
CVD223		2.0 A or more
CVD228		2.5 A or more
CVD242		3.6 A or more
CVD245		3.9 A or more

### ● 5-Phase Motor

Driver model	Input power supply voltage	Power supply current capacity
CVD503	+24 VDC±10%	0.6 A or more
CVD507		1.4 A or more
CVD512		1.7 A or more
CVD514		1.8 A or more
CVD518		2.8 A or more
CVD524		2.7 A or more
CVD528		3.5 A or more

### Note

- When connecting, pay attention to the polarity of the power supply. Reverse-polarity connection may cause damage to the driver.
- Have the connector plugged in securely. Insecure connection may cause malfunction or damage to the driver.

### memo

- When unplugging the connector, do so while spreading the latches on the connector a little.
- When cycling the power or plugging/unplugging the connector, turn off the power and wait for the PWR/ALM LED to turn off.
- Separate I/O cable at least 100 mm (3.94 in.) from electromagnetic relays and other than inductance loads. Additionally, route I/O cable perpendicular to power supply cable and motor cable, rather than in a parallel fashion.
- Do not route the power supply cable in the same conduits as other power supply lines and motor cable.
- If the motor cable or power supply cable generates an undesirable amount of noise depending on the wiring or configuration, shield the cable or install a ferrite core.

## ■ Explanation of I/O signals

### ● Input signals

The signal input state represents "ON: Carrying current" or "OFF: Not carrying current" state of the internal photocoupler.

The interval for switching the motor direction represents the response time of the circuit. Set this interval to an appropriate time after which the motor will respond.

#### ● CW (PLS) input, CCW (DIR) input

Set a desired pulse input mode of the driver according to the pulse output mode of the controller used with the driver.

#### Maximum input pulse frequency (duty cycle is 50%)

- When the controller is of line driver type: 1 MHz
- When the controller is of open-collector type: 250 kHz

#### 2-pulse input mode

When the CW input is turned from OFF to ON, the motor will rotate by one step in CW direction.

When the CCW input is turned from OFF to ON, the motor will rotate by one step in CCW direction.



- When the motor is at standstill, be sure to keep the photocoupler in OFF state.
- Do not input the CW pulse and CCW pulse simultaneously. If the other pulse is input while one of the pulse is ON, the motor cannot operate normally.

#### 1-pulse input mode

When the PLS input is turned from OFF to ON while the DIR input is ON, the motor will rotate by one step in CW direction.

When the PLS input is turned from OFF to ON while the DIR input is OFF, the motor will rotate by one step in CCW direction.

#### Pulse signal

Pulses with sharp rising and falling edges should be input as shown in the figure below. The figure shows the voltage levels of pulse signals.

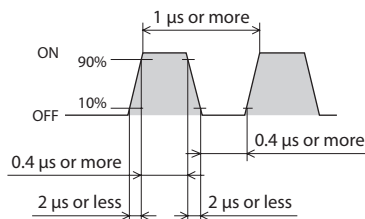

#### ● AWO (all windings off) input

When the AWO input is turned ON, the motor current will be cut off and the motor will lose its holding torque. The motor output shaft can be turned manually.

When the AWO input is turned OFF, current will be supplied and the holding torque will be restored.

#### ● CS (step angle switching) input

When the CS input is turned ON, the motor rotates at a basic step angle. When the CS input is turned OFF, the motor rotates at the step angle set by the driver STEP switch.



- Do not change the CS input while operating. The motor may lose its synchronism, causing position deviation or standstill of the motor.
- When changing the step angle using the CS input, do so while the TIM output is ON.

### ● Output signals

The driver outputs signals are photocoupler/open-collector output. The signal output state represents "ON: Carrying current" or "OFF: Not carrying current" state of the internal photocoupler.

#### ● ALM (alarm) output

The ALM output is normally closed. When an alarm generates, the ALM output will turn OFF and the motor current will be cut off.

At the same time, the PWR/ALM LED of the driver will blink in red.

#### ● TIM (timing) output

Every time the motor output shaft rotates by 7.2° (3.6° for high-resolution type), the motor excitation state becomes the initial setting state (step 0), and the TIM output turns ON. If an AND circuit is configured with signals of the home sensor and TIM output when the home position in the equipment is detected, the tolerance for the motor stop positions in a detection range of the home sensor can be reduced and the further accurate home position can be detected.

#### Example of the TIM output when the step angle is 0.72° (resolution 500 P/R)

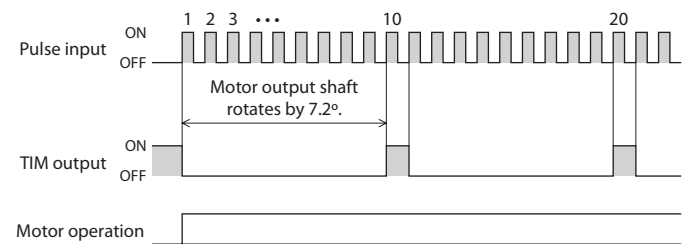

	Motor type	Number of divisions		TIM output
		1	10	
Standard	Base step angle 1.8°/step	1.8°	0.18°	every 7.2°
	Base step angle 0.72°/step	0.72°	0.072°	
High-resolution	Base step angle 0.36°/step	0.36°	0.036°	every 3.6°



- When using the TIM output, keep the input pulse frequency to be 500 Hz or less.
- When using the TIM output, set the pulse or step angle so that the motor output shaft stops at an integral multiple of 7.2°.

## ■ Timing chart

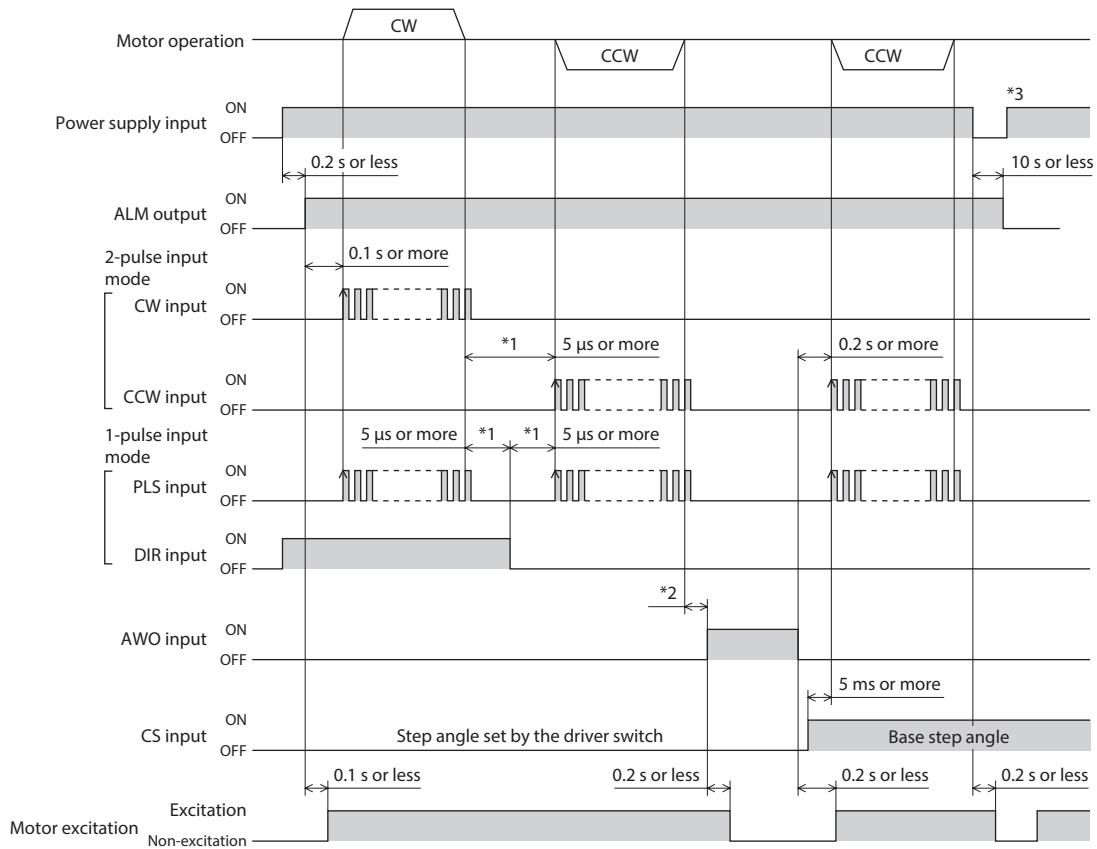

\*1 The interval for switching the motor direction represents the response time of the circuit. Set this interval to an appropriate time after which the motor will respond.

\*2 It varies depending on the moment of load inertia, load torque, starting frequency, and so on.

\*3 When cycling the power, turn off the power and wait for the PWR/ALM LED to turn off.

## ■ Noise measures

The electrical noise is of two types: One is a noise to invade into the driver from the outside and cause the driver malfunction, and the other is a noise to emit from the driver and cause peripheral equipments malfunction.

For the noise that is invaded from the outside, take measures to prevent the driver malfunction. It is needed to take adequate measures because signal lines are very likely to be affected by the noise.

For the noise that is emitted from the driver, take measures to suppress it.

### ● Measures against electrical noise

There are the following three methods mainly to take measures against the electrical noise.

#### ● Noise suppression

- When relays or electromagnetic switches are used together with the system, use noise filters and CR circuits to suppress surges generated by them.
- Cover the driver by a metal plate such as aluminum. This is effective in shielding the electrical noise emitted from the driver.

#### ● Prevention of noise propagation

- Connect a noise filter on the input side of the DC power supply.
- Place the power lines, such as the motor and power supply cables, keeping a distance of 100 mm (3.94 in.) or more from the signal lines, and also do not bundle them or wire them in parallel. If the power cables and signal cables have to cross, cross them at a right angle.
- Use shielded twisted pair cables of AWG22 (0.3 mm<sup>2</sup>) or thicker for power lines and AWG24 (0.2 mm<sup>2</sup>) or thicker for signal lines.
- Keep cables as short as possible without coiling and bundling extra lengths.

- To ground a shielded cable, use a metal cable clamp that will maintain contact with the entire circumference of the cable. Ground the cable clamp near the product.

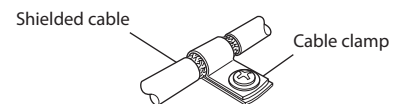

- When grounding PE terminals of multiple drivers to a grounding point, it becomes more effective to block the electrical noise since impedance on the grounding point is decreased. However, ground them so that a potential difference does not occur among the grounding points. An accessory connection cable (for signal) that includes a ground wire is provided (sold separately). Refer to p.11 for details.

#### ● Suppression of effect by noise propagation

- Loop the noise propagated cable around a ferrite core. Doing so will prevent the propagated noise invades into the driver or emits from the driver. The frequency band in which an effect by the ferrite core can be seen is generally 1 MHz or more. Check the frequency characteristics of the ferrite core used. To increase the effect of noise attenuation by the ferrite core, loop the cable a lot.
- Use the line driver type, which is less likely to be affected by electrical noise, for the output circuit of pulse signals. If the pulse signal of the controller is of the open collector type, use an accessory pulse signal converter for noise immunity (sold separately). Refer to p.11 for details.



## ● Noise suppression parts

### ● Noise filter

- Connect a noise filter (or equivalent) in the table below on the input side of the DC power supply. When a power supply transformer is used, be sure to connect a noise filter on the AC input side of the power supply transformer. Doing so will prevent the propagated noise through the power line. Install the noise filter as close to the driver as possible.

Manufacturer	Model
SOSHIN ELECTRIC CO.,LTD	HF2010A-UPF
Schaffner EMC	FN2070-10-06

- Use the AWG18\* (0.75 mm<sup>2</sup>) or thicker wire for the input and output cables of the noise filter, and secure firmly using a cable clamp etc. so that the cable does not come off the enclosure.
  - \* AWG20 (0.5 mm<sup>2</sup>) or thicker wire for the CVD242BR-K, CVD245BR-K, and CVD528BR-K
- Place the input cable as far apart as possible from the output cable, and do not wire the cables in parallel. If the input and output cable are placed at a close distance or if they are wired in parallel, the noise in the enclosure affects the power cable through stray capacitance, and the noise suppressing effect will reduce.
- Connect the ground terminal of the noise filter to the grounding point, using as thick and short a wire as possible.
- When connecting a noise filter in an enclosure, wire the input cable of the noise filter as short as possible. Wiring in long distance may reduce the noise suppressing effect.

#### ● Recommended wiring example

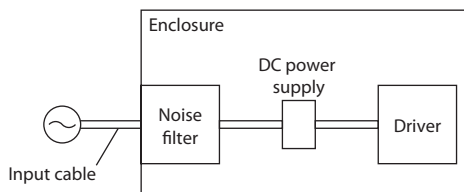

#### ● Wiring example where the noise tends to generate

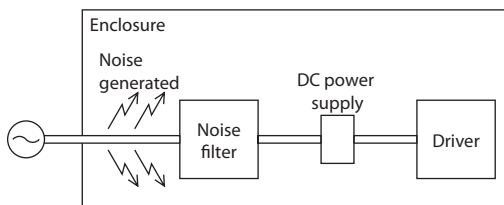

## ● Noise suppression parts (accessories)

Accessories are sold separately. Refer to p.11 for details.

### ● Connection cable (for signal)

This cable is a shielded twisted pair cable for good noise immunity to connect the driver and controller. The ground wires useful to grounding are provided at both ends of the cable. The EMC measures are conducted using the Oriental Motor connection cable (for signal).

### ● Pulse signal converter for noise immunity

This is a noise filter for pulse signal lines. It eliminates the noise of the pulse signal, and converts the pulse signal to the line driver type.

### ● Surge suppressor

This product is effective to suppress the surge which occurs in a relay contact part. Connect it when using a relay or electromagnetic switch. CR circuit for surge suppression and CR circuit module are provided.

## ■ Conformity to the EMC Directive

Effective measures must be taken against the EMI that the motor and driver may give to adjacent control-system equipment, as well as the EMS of the motor and driver itself, in order to prevent a serious functional impediment in the machinery. The use of the following installation and wiring methods will enable the motor and driver to be compliant with the EMC directive. Refer to p.2 for the applicable standards.

Oriental Motor conducts EMC measurements on its motors and drivers in accordance with the following "Example of motor and driver installation and wiring."

The user is responsible for ensuring the machine's compliance with the EMC Directive, based on the installation and wiring explained below.

### ● Connecting noise filter

See the section of "Noise filter" mentioned in the left.

### ● Power supply

The **CVD** Driver is a product of DC power input. Use a DC power supply (switched-mode power supply etc.) that conforms to the EMC Directive.

### ● Connecting the signal cable

Refer to "Prevention of noise propagation" on p.8.

### ● How to ground

- The cable used to ground the motor, driver and noise filter must be as thick and short as possible so that no potential difference is generated.
- Choose a large, thick and uniformly conductive surface for the grounding point.
- Install the motor to the grounded metal plate.

### ● Example of motor and driver installation and wiring

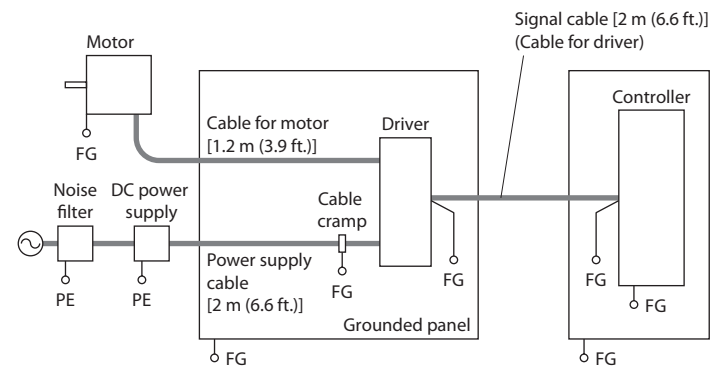

### ● Precautions about static electricity

Static electricity may cause the driver to malfunction or suffer damage. While the driver is receiving power, handle the driver with care and do not come near or touch the driver.

Always use an insulated screwdriver to adjust the driver's switches.



The driver uses parts that are sensitive to electrostatic charge. Before touching the driver, turn off the power to prevent electrostatic charge from generating. If an electrostatic charge is impressed on the driver, the driver may be damaged.

## Setting

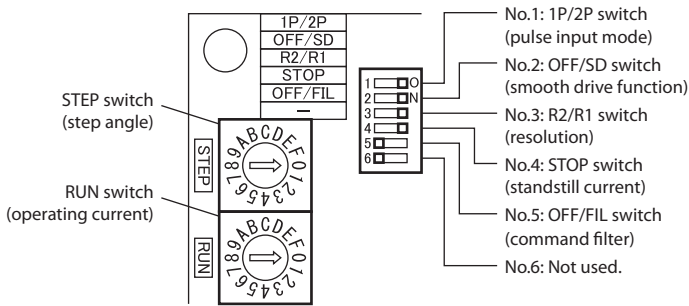

**memo** The STEP switch, 1P/2P switch, and R2/R1 switch are enabled after the power is cycled.

### Step angle

Set the motor step angle using the R2/R1 switch and STEP switch. See the following tables for the step angles that can be set.

#### Factory setting

**R2/R1 switch:** ON side for 5-phase stepping motor (R1)  
 OFF side for 2-phase stepping motor (R2)

**STEP switch:** 0

- When the R2/R1 switch is set to ON side (R1).
- When the R2/R1 switch is set to OFF side (R2).

STEP switch	Resolution (P/R)	Step angle	Resolution (P/R)	Step angle
0	500	0.72°	200	1.8°
1	1000	0.36°	400	0.9°
2	1250	0.288°	800	0.45°
3	2000	0.18°	1000	0.36°
4	2500	0.144°	1600	0.225°
5	4000	0.09°	2000	0.18°
6	5000	0.072°	3200	0.1125°
7	10000	0.036°	5000	0.072°
8	12500	0.0288°	6400	0.05625°
9	20000	0.018°	10000	0.036°
A	25000	0.0144°	12800	0.028125°
B	40000	0.009°	20000	0.018°
C	50000	0.0072°	25000	0.0144°
D	62500	0.00576°	25600	0.0140625°
E	100,000	0.0036°	50000	0.0072°
F	125,000	0.00288°	51200	0.00703125°

- memo**
- Step angles are theoretical values.
  - Do not change the CS input or switch while operating. Doing so may cause loss of synchronism of the motor, resulting in the motor standstill.
  - For the high-resolution type, in comparison with the standard type the resolution is twice and the step angle is one-half. Example: When the R2/R1 switch is set to the ON side (R1) and the STEP switch is set to "0"  
 Resolution of the high-resolution type:  $500 \times 2 = 1000$   
 Step angle of the high-resolution type:  $0.72^\circ / 2 = 0.36^\circ$

### Pulse input mode

Set a desired pulse input mode of the driver according to the pulse output mode of the controller used with the driver. Set a desired mode using the 1P/2P switch. The factory setting of the pulse input mode depends on the destination country.

### Smooth drive function

The smooth drive is a function to achieve lower vibration and noise at low speeds operation without changing the step angle setting. This function divides the step angle automatically in response to the pulse signals. It is no need to change the setting of the pulse signals (speed, number of pulses) on the controller side. Set the smooth drive function with the OFF/SD switch.

**Factory setting** ON side (SD) [smooth drive function is enable.]

### Operating current

The motor current for when inputting pulses (operating current) can be changed with the RUN switch. If the load is small and there is an ample allowance for torque, motor temperature rise can be suppressed by setting a lower operating current. The operating current is a value in which the operating current rate is multiplied by the rated current (100%).  
 Operating current = Motor rated current x operating current rate

**Factory setting** F (operating current rate 100%)

RUN switch	Operating current rate	RUN switch	Operating current rate
0	25%	8	65%
1	30%	9	70%
2	35%	A	75%
3	40%	B	80%
4	45%	C	85%
5	50%	D	90%
6	55%	E	95%
7	60%	F	100%

### Standstill current

When the motor stops, the current cutback function will be actuated to lower the motor current to the standstill current. The driver standstill current rate can be switched between 25% and 50% using the STOP switch. When setting the switch to the OFF side, the standstill current rate will be set to 25%. When setting the switch to the ON side, the standstill current rate will be set to 50%. The standstill current is a value in which the standstill current rate is multiplied by the operating current.  
 Standstill current = Operating current set with the RUN switch x Standstill current rate

**Factory setting** ON side (standstill current rate 50%)

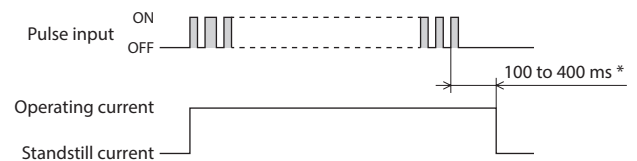

\* The specific time varies depending on the load or operating pattern.

## ■ Command filter

The motor response corresponding to input pulses can be adjusted with the OFF/FIL switch. When the switch is set to the ON side, starting/stopping of the motor becomes smooth. Note, however, that synchronization performance in response to the commands is decreased. Set an appropriate value according to the specific load and purpose.

### Factory setting OFF side (command filter is not used)

- When the command filter is not used

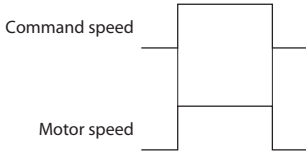

- When the command filter is used

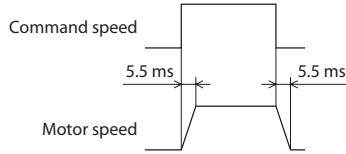

## Inspection

It is recommended that periodic inspections are conducted for the items listed below after each operation of the motor. If an abnormal condition is noted, discontinue any use and contact your nearest Oriental Motor sales office.

### During inspection

- Are any of the mounting screws or connection parts of the driver loose?
- Is there attachment of dust, etc., on the driver?
- Are there any strange smells or appearances within the driver?



The driver uses semiconductor elements, so be extremely careful when handling them. Static electricity may damage the driver.

## Alarms

When the driver's protective function triggers and an alarm generates, the ALM output is turned OFF and the motor current is cut off. At the same time, the PWR/ALM LED will blink in red. The cause of the alarm can be checked by counting the number of times the PWR/ALM LED blinks.

### ● Alarm list

No. of LED blinks	Alarm type	Cause and remedial action
2	Overheat	<p><b>[Cause]</b> The temperature of the driver circuit board reached 85 °C (185 °F).</p> <p><b>[Remedial action]</b> Review the ventilation condition.</p>
3	Overvoltage	<p><b>[Cause]</b> A voltage exceeding the specification value was applied.</p> <p><b>[Remedial action]</b> Check the input voltage of the power supply.</p> <hr/> <p><b>[Cause]</b> A large inertial load was stopped abruptly. Elevating drive of a large inertia load was performed.</p> <p><b>[Remedial action]</b> If this alarm generates during operation, reduce the load or increase the acceleration/deceleration.</p>
5	Overcurrent	<p><b>[Cause]</b> Excessive current has flown through the output circuit in the driver.</p> <p><b>[Remedial action]</b> Turn off the power and check that the motor, cable and driver are not damaged.</p>

No. of LED blinks	Alarm type	Cause and remedial action
9	EEPROM error	<p><b>[Cause]</b> The stored data was damaged.</p> <p><b>[Remedial action]</b> Contact your nearest Oriental Motor sales office.</p>
Lit	CPU error	<p><b>[Cause]</b> CPU malfunctioned.</p> <p><b>[Remedial action]</b> Cycle the power.</p>

### ● Alarm reset

When the power is cycled, the alarm will be reset. Before resetting an alarm, always remove the cause of the alarm and ensure safety.

## Accessories (sold separately)

### ■ Connection cable (for signal)

This is a shielded twisted pair cable for the driver control I/O (12 pins) that has good noise immunity. The ground wires useful to grounding are provided at both ends of the cable.

Model	Length [m (ft.)]	Conductor
CC12D005-2	0.5 (1.6)	AWG24 (0.2 mm <sup>2</sup> )
CC12D010-2	1 (3.3)	
CC12D015-2	1.5 (4.9)	
CC12D020-2	2 (6.6)	

### ■ Pulse signal converter for noise immunity

This product eliminates the noise of the pulse signal, and converts the pulse signal to the line driver type.

Model: VCS06

### ■ CR circuit for surge suppression

This product is effective to suppress the surge which occurs in a relay contact part. Use it to protect the contacts of the relay or switch.

Model: EPCR1201-2

### ■ CR circuit module

This product is effective to suppress the surge which occurs in a relay contact part. Use this product to protect the contacts of the relay or switch.

4 pieces of CR circuit for surge suppression are mounted on the compact circuit, and this product can be installed to the DIN rail. This product can make the wiring easily and securely since it also supports terminal block connection.

Model: VCS02

- Unauthorized reproduction or copying of all or part of this manual is prohibited.
- Oriental Motor shall not be liable whatsoever for any problems relating to industrial property rights arising from use of any information, circuit, equipment or device provided or referenced in this manual.
- Characteristics, specifications and dimensions are subject to change without notice.
- While we make every effort to offer accurate information in the manual, we welcome your input. Should you find unclear descriptions, errors or omissions, please contact the nearest office.
- **Orientalmotor** is a registered trademark or trademark of Oriental Motor Co., Ltd., in Japan and other countries.

© Copyright ORIENTAL MOTOR CO., LTD. 2015

- Please contact your nearest Oriental Motor office for further information.

ORIENTAL MOTOR U.S.A. CORP.  
 Technical Support Tel:(800)468-3982  
 8:30 A.M. to 5:00 P.M., P.S.T. (M-F)  
 7:30 A.M. to 5:00 P.M., C.S.T. (M-F)  
[www.orientalmotor.com](http://www.orientalmotor.com)

ORIENTAL MOTOR DO BRASIL LTDA.  
 Tel:+55-11-3266-6018  
[www.orientalmotor.com.br](http://www.orientalmotor.com.br)

ORIENTAL MOTOR (EUROPA) GmbH  
 Headquarters Düsseldorf, Germany  
 Technical Support Tel:00 800/22 55 66 22  
[www.orientalmotor.de](http://www.orientalmotor.de)

ORIENTAL MOTOR (UK) LTD.  
 Tel:01256-347090  
[www.oriental-motor.co.uk](http://www.oriental-motor.co.uk)

ORIENTAL MOTOR (FRANCE) SARL  
 Tel:01 47 86 97 50  
[www.orientalmotor.fr](http://www.orientalmotor.fr)

ORIENTAL MOTOR ITALIA s.r.l.  
 Tel:02-93906346  
[www.orientalmotor.it](http://www.orientalmotor.it)

ORIENTAL MOTOR CO., LTD.  
 Headquarters Tokyo, Japan  
 Tel:03-6744-0361  
[www.orientalmotor.co.jp](http://www.orientalmotor.co.jp)

ORIENTAL MOTOR ASIA PACIFIC PTE. LTD.  
 Singapore  
 Tel:1800-8420280  
[www.orientalmotor.com.sg](http://www.orientalmotor.com.sg)

ORIENTAL MOTOR (MALAYSIA) SDN. BHD.  
 Tel:1800-806161  
[www.orientalmotor.com.my](http://www.orientalmotor.com.my)

ORIENTAL MOTOR (THAILAND) CO., LTD.  
 Tel:1800-888-881  
[www.orientalmotor.co.th](http://www.orientalmotor.co.th)

ORIENTAL MOTOR (INDIA) PVT. LTD.  
 Tel:+91-80-41125586  
[www.orientalmotor.co.in](http://www.orientalmotor.co.in)

TAIWAN ORIENTAL MOTOR CO., LTD.  
 Tel:0800-060708  
[www.orientalmotor.com.tw](http://www.orientalmotor.com.tw)

SHANGHAI ORIENTAL MOTOR CO., LTD.  
 Tel:400-820-6516  
[www.orientalmotor.com.cn](http://www.orientalmotor.com.cn)

INA ORIENTAL MOTOR CO., LTD.  
 Korea  
 Tel:080-777-2042  
[www.inaom.co.kr](http://www.inaom.co.kr)

ORIENTAL MOTOR CO., LTD.  
 Hong Kong Branch  
 Tel:+852-2427-9800