



Closed Loop Stepping Motor and Driver Package

αSTEP

High-efficiency AR Series

DC power input

Pulse input type

USER MANUAL

CE

Thank you for purchasing an Oriental Motor product.

This Operating Manual describes product handling procedures and safety precautions.



- Please read it thoroughly to ensure safe operation.
- Always keep the manual where it is readily available.

Table of contents

1	Safety precautions.....	3	12	Extended functions.....	42
2	Overview of the AR Series	5	■ Application parameters	42	
3	System configuration.....	6	■ System parameters	43	
4	Introduction.....	8	12.1	Setting.....	43
5	Precautions for use	9	■ Resolution	43	
6	Preparation.....	11	■ Pulse input mode.....	44	
6.1	Checking the product	11	■ Motor excitation at power ON	46	
6.2	How to identify the product model.....	11	■ Automatic return operation	46	
6.3	Combinations of motors and drivers ...	12	■ Setting the motor rotation direction	47	
6.4	Input/output power ratings.....	13	■ Setting the positioning completion (END) signal offset.....	47	
6.5	Names and functions of parts	13	12.2	Operation	48
7	Installation	15	■ Push-motion operation	48	
7.1	Location for installation	15	■ Test operation	49	
7.2	Installing the motor.....	15	■ Return to electrical home operation.....	49	
7.3	Installing a load	16	12.3	Adjustment	50
7.4	Permissible overhung load and permissible thrust load	17	■ Control mode	50	
7.5	Installing the driver	18	■ Operating current	50	
7.6	Installing and wiring in compliance with EMC Directive.....	19	■ Standstill current	50	
8	Connection	21	■ Speed filter	51	
8.1	Connecting the motor.....	21	■ Smooth drive.....	51	
8.2	Connecting the electromagnetic brake motor	22	■ Speed error gain	51	
8.3	Connecting the I/O signals.....	23	■ Position loop gain, speed loop gain, speed loop integral time constant.....	51	
8.4	Connecting the power supply and grounding the driver	29	■ Anti-vibration control	51	
8.5	Connecting the data setter	30	13	Inspection	52
9	Quick operations	31	14	Alarms and warnings	53
10	Explanation of I/O signals.....	33	14.1	Alarms	53
10.1	Input signals	33	■ Alarm reset.....	53	
10.2	Output signals	37	■ Descriptions of alarms	54	
10.3	Timing chart.....	39	14.2	Warnings	56
11	Setting	40	■ Descriptions of warnings	56	
11.1	Resolution	40	15	Troubleshooting and remedial actions	57
11.2	Pulse input mode	40	16	General specifications	58
11.3	Operating current	41	17	Accessories (sold separately).....	59
11.4	Speed filter	41	18	Reference.....	62
			18.1	Timing charts.....	62
			18.2	Function/parameter list.....	70
			18.3	Warning/alarm lists.....	76
			■ Alarms (protective functions)	76	
			■ Warnings (warning functions).....	78	

1 Safety precautions

The precautions described below are intended to prevent danger or injury to the user and other personnel through safe, correct use of the product. Use the product only after carefully reading and fully understanding these instructions.

 Warning	Handling the product without observing the instructions that accompany a "Warning" symbol may result in serious injury or death.
 Caution	Handling the product without observing the instructions that accompany a "Caution" symbol may result in injury or property damage.
Note	The items under this heading contain important handling instructions that the user should observe to ensure safe use of the product.

Warning

General

- Do not use the product in explosive or corrosive environments, in the presence of flammable gases, locations subjected to splashing water, or near combustibles. Doing so may result in fire or injury.
- Assign qualified personnel the task of installing, wiring, operating/controlling, inspecting and troubleshooting the product. Failure to do so may result in fire, injury or damage to equipment.
- When the driver generates an alarm (any of the driver's protective functions is triggered), take measures to hold the moving part in place since the motor stops and loses its holding torque. Failure to do so may result in injury or damage to equipment.
- When the driver generates an alarm (any of the driver's protective functions is triggered), first remove the cause and then clear the protection function. Continuing the operation without removing the cause of the problem may cause malfunction of the motor and driver, leading to injury or damage to equipment.
- Do not transport, install the product, perform connections or inspections when the power is on. Always turn the power off before carrying out these operations. Failure to do so may result in electric shock.
- Take measures to keep the moving parts in position for vertical operations such as elevator applications. The motor loses holding torque when the power is shut off, allowing the moving parts to fall and possibly cause injury or damage to equipment.
- The brake mechanism of an electromagnetic brake motor is used to keep the moving part and motor in position. Do not use it as a deceleration/safety brake. Doing so may result in injury or damage to the equipment.

Installation

- Install the motor and driver in the enclosure in order to prevent injury.
- When installing the motor and driver, do not touch the driver without grounding the driver first. Failure to do so may result in electric shock.

Connection

- Keep the driver's input power voltage within the specified range. Failure to do so may result in fire.
- For the driver's power supply, use a DC power supply with reinforced insulation on its primary and secondary sides. Failure to do so may result in electric shock.
- Connect the cables securely according to the wiring diagram. Failure to do so may result in fire.
- Do not forcibly bend, pull or pinch the cable. Doing so may cause fire.

Operation

- Turn off the driver power in the event of a power failure. Or the motor may suddenly start when the power is restored and may cause injury or damage to equipment.
- Do not turn the FREE input to ON while the motor is operating. The motor will stop and lose its holding power. Doing so may result in injury or damage to equipment.

Repair, disassembly and modification

- Do not disassemble or modify the motor and driver. Doing so may cause injury. Refer all such internal inspections and repairs to the branch or sales office from which you purchased the product.

 **Caution**

General

- Do not use the motor and driver beyond its specifications. Doing so may result in injury or damage to equipment.
- Keep your fingers and objects out of the openings in the motor and driver. Failure to do so may result in fire or injury.
- Do not touch the motor and driver during operation or immediately after stopping. The surface is hot and may cause a skin burn(s).

Transportation

- Do not carry the motor by holding the motor output shaft or motor cable. Doing so may cause injury.

Installation

- Provide a cover over the rotating parts (output shaft) of the motor. Failure to do so may result in injury.
- Do not leave anything around the motor and driver that would obstruct ventilation. Doing so may result in damage to equipment.

Connection

- The main power supply connector (CN1), data edit connector (CN4) and I/O signal connector (CN5) of the driver are not electrically insulated. When grounding the positive terminal of the power supply, do not connect any equipment (PC, etc.) whose negative terminal is grounded. Doing so may cause the driver and these equipment to short, damaging both.

Operation

- Do not touch the rotating part (output shaft) during operation. Doing so may cause injury.
- Use a motor and driver only in the specified combination. An incorrect combination may cause a fire.
- Provide an emergency stop device or emergency stop circuit external to the equipment so that the entire equipment will operate safely in the event of a system failure or malfunction. Failure to do so may result in injury.
- The motor surface temperature may exceed 70 °C (158 °F) even under normal operating conditions. If the operator is allowed to approach the running motor, attach a warning label as shown below in a conspicuous position. Failure to do so may result in skin burn(s). 
- Before supplying power to the driver, turn all input signals to the driver OFF. Otherwise, the motor may start suddenly at power ON and cause injury or damage to equipment. **Warning label**
- Before moving the motor directly with the hands, confirm that the FREE input turns ON. Failure to do so may result in injury.
- Immediately when trouble has occurred, stop running and turn off the driver power. Failure to do so may result in fire or injury.

Maintenance and inspection

- To prevent the risk of electric shock, do not touch the terminals while performing the insulation resistance test or dielectric strength test.

Disposal

- To dispose of the motor and driver, disassemble it into parts and components as much as possible and dispose of individual parts/components as industrial waste.

2 Overview of the AR Series

The **AR** Series high-efficiency stepping motor and driver package is a product consisting of a stepping motor equipped with a rotor position detection sensor, and a high-performance microstep driver.

When the **AR** Series is used with an accessory data setter **OPX-2A** or data editing software **MEXE02** (both are sold separately), push-motion operation can be performed in addition to accurate positioning operation.

■ Main features

- Introducing closed loop control

The **AR** Series can continue its operation even upon encountering quick acceleration or an abrupt change in load. Monitoring the speed and amount of rotation while the motor is running, the **AR** Series performs the closed-loop control under overload and similar conditions to continue its operation at the maximum torque.

- Energy-saving

Motor and driver losses have been substantially reduced to achieve low heat generation and save energy. Since the motor and driver generate much less heat, they can now be operated for longer hours at high speed, which was not possible with conventional motors/drivers.

- Easy adjustment using a speed filter

Even after the motor has been installed in the equipment, the motor response can be adjusted to suppress vibration using a digital switch with ease.

- Supporting sink output and source output

The driver supports both the current sink output circuit and the current source output circuit. (Line driver output is not supported).

- Alarm and warning functions

The driver provides alarms that are designed to protect the driver from overheating, poor connection, error in operation, etc. (protective functions), as well as warnings that are output before the corresponding alarms generate (warning functions).

■ Various operation modes

Positioning operation and return to electrical home operation can be performed. Push-motion operation can be performed when using an accessory data setter **OPX-2A** or data editing software **MEXE02** (both are sold separately).

■ Extended functions

When used with the accessory data setter **OPX-2A** or the data editing software **MEXE02** (both are sold separately), the **AR** Series driver lets you set desired parameters, operation mode, resolution and other items according to your equipment. For details, refer to page 42.

3 System configuration

All you need is to turn the C-ON input ON and input pulses!

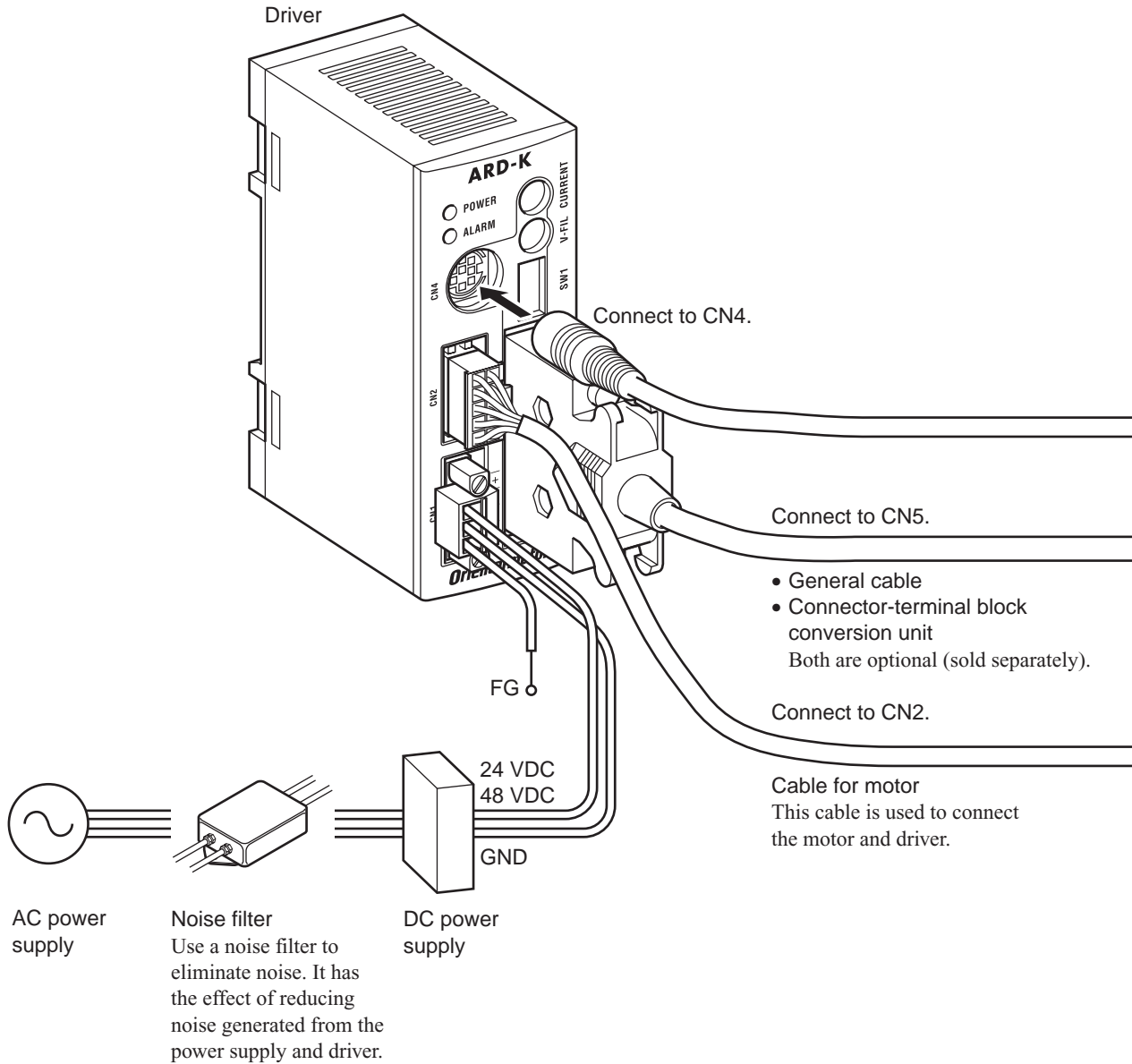

Extend functions are made available through use of accessories (sold separately)!

Data setter **OPX-2A**

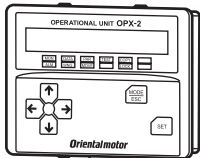

Or

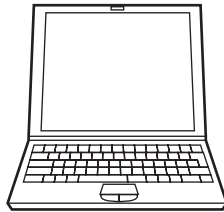

PC in which the data editing software **MEXE02** has been installed
The customer must provide a PC.

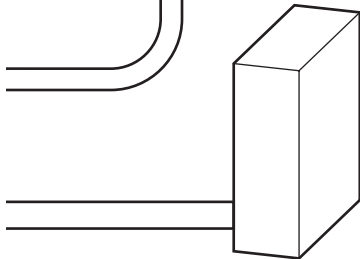

Controller
Connect a controller with pulse oscillation function.

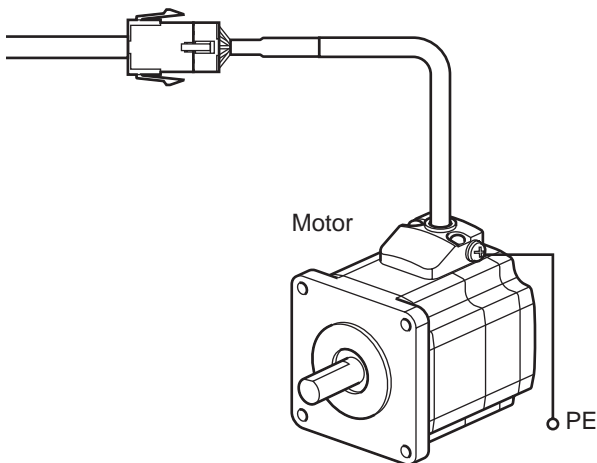

Easy setting using switches!

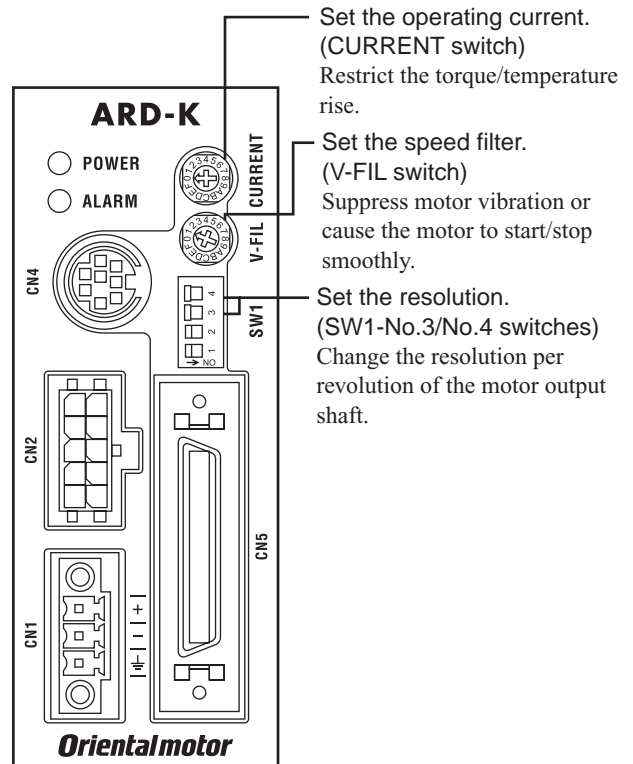

4 Introduction

■ Before use

Only qualified personnel should work with the product.

Use the product correctly after thoroughly reading the section "1 Safety precautions" on page.3.

The product described in this manual has been designed and manufactured for use in general industrial equipment.

Do not use for any other purpose. Oriental Motor Co., Ltd. is not responsible for any damage caused through failure to observe this warning.

■ Operating Manuals for the AR Series

Operating manuals for the **AR** Series are listed below.

After reading the above manuals, keep them in a convenient place so that you can reference them at any time.

Applicable product	Type of operating manual	Description of operating manual
AR Series DC power input Pulse input type	Motor OPERATING MANUAL (Supplied with motor)	This manual explains the functions as well as the installation method and others for the motor.
	Driver OPERATING MANUAL (Supplied with driver)	This manual explains the functions as well as the installation method and others for the driver.
	USER MANUAL	This manual explains the function, installation and connection of the motor and driver as well as operating method.
Data setter OPX-2A	OPERATING MANUAL	This manual explains how to set data using the accessory data setter OPX-2A (sold separately).
Data setting software MEXE02	OPERATING MANUAL	This manual explains how to set data using the accessory data setting software MEXE02 .

■ CE Marking

• Low Voltage Directives

Because the input power supply voltage of this product is 24 VDC/48 VDC, it is not subject to the Low Voltage Directive but install and connect this product as follows.

- This product is designed and manufactured to be installed within another device. Install the product in an enclosure.
- For the driver power supply, use a DC power supply with reinforced insulation on its primary and secondary sides.

• EMC Directive

This product has received EMC compliance under the conditions specified in "Example of motor and driver installation and wiring" on page.20.

Since the compliance of the final machinery with the EMC Directive will depend on such factors as the configuration, wiring, layout and risk involved in the control-system equipment and electrical parts, it therefore must be verified through EMC measures by the customer of the machinery.

Applicable standards

EMI	EN 61000-6-4, EN 61800-3 EN 55011 group 1 class A
EMS	EN 61000-6-2, EN 61800-3

■ Hazardous substances

The products do not contain the substances exceeding the restriction values of RoHS Directive (2011/65/EU).

5 Precautions for use

This section covers limitations and requirements the user should consider when using the product.

- Always use the cable (supplied or accessory) to connect the motor and driver.

Be sure to use the cable (supplied or accessory) to connect the motor and driver.

In the following condition, an appropriate accessory cable must be purchased separately. Refer to page 59 for details.

- If a flexible cable is to be used.
- If a cable of 3 m (9.8 ft.) or longer is to be used.
- If a motor and driver package without a cable was purchased.

- Perform the insulation resistance test or dielectric strength test separately on the motor and the driver.

Performing the insulation resistance test or dielectric strength test with the motor and driver connected may result in damage to the product.

- Do not apply an overhung load and thrust load in excess of the specified permissible limit

Operating the motor under an excessive overhung load or thrust load may damage the motor bearings (ball bearings). Be sure to operate the motor within the specified permissible limit of overhung load and thrust load. See page 17 for details.

- Use the motor in conditions where its surface temperature will not exceed 100 °C (212 °F).

The driver has an overheat protection function, but the motor has no such feature. The motor surface temperature may exceed 100 °C (212 °F) under certain conditions (ambient temperature, operating speed, duty cycle, etc.). To prevent the motor bearings (ball bearings) from reaching its usable life quickly, use the motor in conditions where the surface temperature will not exceed 100 °C (212 °F).

Use the geared type motor in a condition where the gear case temperature does not exceed 70 °C (158 °F), in order to prevent deterioration of grease and parts in the gear case.

If the motor is to be operated continuously, install the motor in a location where heat dissipation capacity equivalent to a level achieved with a heat sink [made of aluminum, 250×250×6 mm (9.84×9.84×0.24 in.)] is ensured.

- Double shaft type motor

Do not apply load torque, overhung load or thrust load to the output shaft on the opposite side of the motor output shaft.

- Holding torque at standstill

The motor holding torque is reduced by the current cutback function of the driver at motor standstill. When selecting a motor for your application, consider the fact that the holding torque will be reduced at motor standstill.

- Do not use the electromagnetic brake to reduce speed or as a safety brake.

Do not use the electromagnetic brake as a means to decelerate and stop the motor. The brake hub of the electromagnetic brake will wear significantly and the braking force will drop. Since the power off activated type electromagnetic brake is equipped, it helps maintain the position of the load when the power is cut off, but this brake cannot securely hold the load in place. Accordingly, do not use the electromagnetic brake as a safety brake. To use the electromagnetic brake to hold the load in place, do so after the motor has stopped.

- Preventing electrical noise

See "7.6 Installing and wiring in compliance with EMC Directive" on page.19 for measures with regard to noise.

- Saving data to the non-volatile memory

Do not turn off the main power supply while writing the data to the non-volatile memory and 5 seconds after the completion of writing the data. Doing so may abort writing the data and cause an EEPROM error alarm to generate. The non-volatile memory can be rewritten approximately 100,000 times.

- Motor excitation at power ON

Simply turning on the power will not excite the motor. To excite the motor, always turn the C-ON input ON.

It is possible to set the motor to be excited automatically after the power has been turned on, by changing the applicable driver parameter using the data setter **OPX-2A** or data editing software **MEXE02**.

- Overvoltage alarm by regeneration energy

The overvoltage alarm will generate depending on the operating condition. When an alarm is generated, review the operating conditions.

- **Note on connecting a power supply whose positive terminal is grounded**

The main power supply connector (CN1), data edit connector (CN4) and I/O signal connector (CN5) of the driver are not electrically insulated. When grounding the positive terminal of the power supply, do not connect any equipment (PC, etc.) whose negative terminal is grounded. Doing so may cause the driver and these equipment to short, damaging both. Use the data setter **OPX-2A** to set data, etc.

- **Do not perform push-motion operation with geared motors.**

Doing so may result in damage to the motor or gear part.

- **Maximum torque of geared type motor**

Always operate the geared type motor under a load not exceeding the maximum torque. If the load exceeds the maximum torque, the gear will be damaged.

- **Grease of geared type motor**

On rare occasions, a small amount of grease may ooze out from the geared type motor. If there is concern over possible environmental damage resulting from the leakage of grease, check for grease stains during regular inspections. Alternatively, install an oil pan or other device to prevent leakage from causing further damage. Oil leakage may lead to problems in the customer's equipment or products.

- **Rotation direction of the gear output shaft**

The relationship between the rotation direction of the motor shaft and that of the gear output shaft changes as follows, depending on the gear type and gear ratio.

Type of gear	Gear ratio	Rotation direction (relative to the motor rotation direction)
TH geared	3.6, 7.2, 10	Same direction
	20, 30	Opposite direction
PS geared PN geared	All gear ratios	Same direction
Harmonic geared	All gear ratios	Opposite direction

6 Preparation

This chapter explains the items you should check, as well as the name and function of each part.

6.1 Checking the product

Verify that the items listed below are included. Report any missing or damaged items to the branch or sales office from which you purchased the product.

Verify the model number of the purchased unit against the number shown on the package label.

Check the model number of the motor and driver against the number shown on the nameplate.

Model names for motor and driver combinations are shown on page 12.

- Motor.....1 unit
- Driver.....1 unit
- CN1 connector (3 pins).....1 pc.
- CN5 connector (36 pins).....1 pc.
- Motor OPERATING MANUAL.....1 copy
- Driver OPERATING MANUAL.....1 copy
- USER MANUAL (CD-ROM).....1 pc.
- Cable for motor.....1 pc.
- Cable for electromagnetic brake.....1 pc. (Supplied with electromagnetic brake motors)
- Parallel key.....1 pc. (Supplied with geared types; except for the **AR24**, **AR46TH** and **AR66TH**).
- Surge suppressor.....1 pc. (Supplied with electromagnetic brake motors)

6.2 How to identify the product model

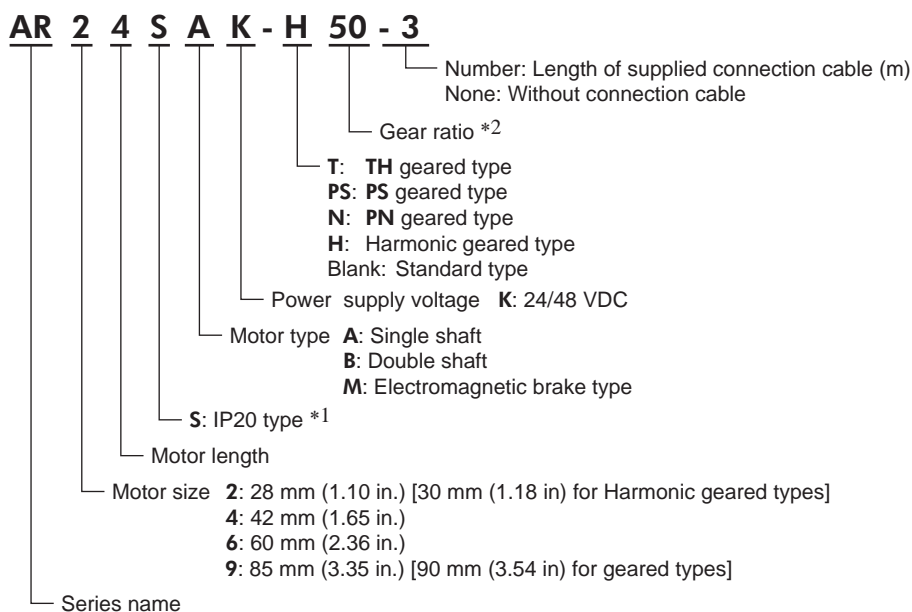

*1 For IP20 type

*2 The model name is "7" for the gear ratio "7.2 : 1" of the **PS** geared type.

6.3 Combinations of motors and drivers

- ■ in the model names indicates a number representing the gear ratio.
- When a connection cable is included, ○ in the model names indicates a number (-1, -2, -3) representing the cable length.

■ Standard type

Model	Motor model	Driver model
AR24SAK○	ARM24SAK	ARD-K
AR24SBK○	ARM24SBK	
AR26SAK○	ARM26SAK	
AR26SBK○	ARM26SBK	
AR46SAK○	ARM46SAK	
AR46SBK○	ARM46SBK	
AR46SMK○	ARM46SMK	
AR46AK○	ARM46AK	
AR46BK○	ARM46BK	
AR46MK○	ARM46MK	
AR66SAK○	ARM66SAK	
AR66SBK○	ARM66SBK	
AR66SMK○	ARM66SMK	
AR66AK○	ARM66AK	
AR66BK○	ARM66BK	
AR66MK○	ARM66MK	
AR69SAK○	ARM69SAK	
AR69SBK○	ARM69SBK	
AR69SMK○	ARM69SMK	
AR69AK○	ARM69AK	
AR69BK○	ARM69BK	
AR69MK○	ARM69MK	
AR98SAK○	ARM98SAK	
AR98SBK○	ARM98SBK	
AR98SMK○	ARM98SMK	
AR98AK○	ARM98AK	
AR98BK○	ARM98BK	
AR98MK○	ARM98MK	

■ PN geared type

Model	Motor model	Driver model
AR24SAK-N■○	ARM24SAK-N□	ARD-K
AR46SAK-N■○	ARM46SAK-N□	
AR46SMK-N■○	ARM46SMK-N□	
AR46AK-N■○	ARM46AK-N□	
AR46MK-N■○	ARM46MK-N□	
AR66SAK-N■○	ARM66SAK-N□	
AR66SMK-N■○	ARM66SMK-N□	
AR66AK-N■○	ARM66AK-N□	
AR66MK-N■○	ARM66MK-N□	
AR98SAK-N■○	ARM98SAK-N□	
AR98SMK-N■○	ARM98SMK-N□	
AR98AK-N■○	ARM98AK-N□	
AR98MK-N■○	ARM98MK-N□	

■ PS geared type

Model	Motor model	Driver model
AR24SAK-PS■○	ARM24SAK-PS□	ARD-K
AR46SAK-PS■○	ARM46SAK-PS□	
AR46SMK-PS■○	ARM46SMK-PS□	
AR46AK-PS■○	ARM46AK-PS□	
AR46MK-PS■○	ARM46MK-PS□	
AR66SAK-PS■○	ARM66SAK-PS□	
AR66SMK-PS■○	ARM66SMK-PS□	
AR66AK-PS■○	ARM66AK-PS□	
AR66MK-PS■○	ARM66MK-PS□	
AR98SAK-PS■○	ARM98SAK-PS□	
AR98SMK-PS■○	ARM98SMK-PS□	
AR98AK-PS■○	ARM98AK-PS□	
AR98MK-PS■○	ARM98MK-PS□	

■ TH geared type

Model	Motor model	Driver model
AR24SAK-T■○	ARM24SAK-T□	ARD-K
AR46SAK-T■○	ARM46SAK-T□	
AR46SMK-T■○	ARM46SMK-T□	
AR46AK-T■○	ARM46AK-T□	
AR46MK-T■○	ARM46MK-T□	
AR66SAK-T■○	ARM66SAK-T□	
AR66SMK-T■○	ARM66SMK-T□	
AR66AK-T■○	ARM66AK-T□	
AR66MK-T■○	ARM66MK-T□	
AR98SAK-T■○	ARM98SAK-T□	
AR98SMK-T■○	ARM98SMK-T□	
AR98AK-T■○	ARM98AK-T□	
AR98MK-T■○	ARM98MK-T□	

■ Harmonic geared type

Model	Motor model	Driver model
AR24SAK-H■○	ARM24SAK-H□	ARD-K
AR46SAK-H■○	ARM46SAK-H□	
AR46SMK-H■○	ARM46SMK-H□	
AR46AK-H■○	ARM46AK-H□	
AR46MK-H■○	ARM46MK-H□	
AR66SAK-H■○	ARM66SAK-H□	
AR66SMK-H■○	ARM66SMK-H□	
AR66AK-H■○	ARM66AK-H□	
AR66MK-H■○	ARM66MK-H□	
AR98SAK-H■○	ARM98SAK-H□	
AR98SMK-H■○	ARM98SMK-H□	
AR98AK-H■○	ARM98AK-H□	
AR98MK-H■○	ARM98MK-H□	

6.4 Input/output power ratings

Frame size [mm (in.)]	Model	Motor model	Driver model	Input		Output current
				Voltage	Current	
28 (1.10)	AR24	ARM24	ARD-K	24 VDC	0.9 A	0.88 A
30 (1.18)	AR26	ARM26			1.4 A	
42 (1.65)	AR46	ARM46		24 VDC 48 VDC	3.1 A	2.55 A
60 (2.36)	AR66	ARM66			3.0 A	
	AR69	ARM69			2.5 A	
85 (3.35)	AR98	ARM98				
90 (3.54)						

6.5 Names and functions of parts

■ Motor (Example: ARM66SMK)

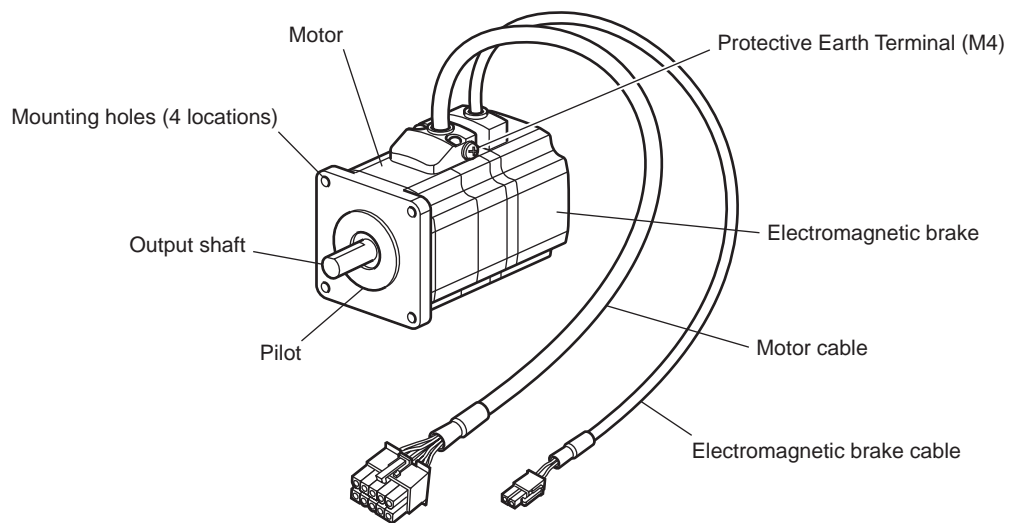

■ Driver

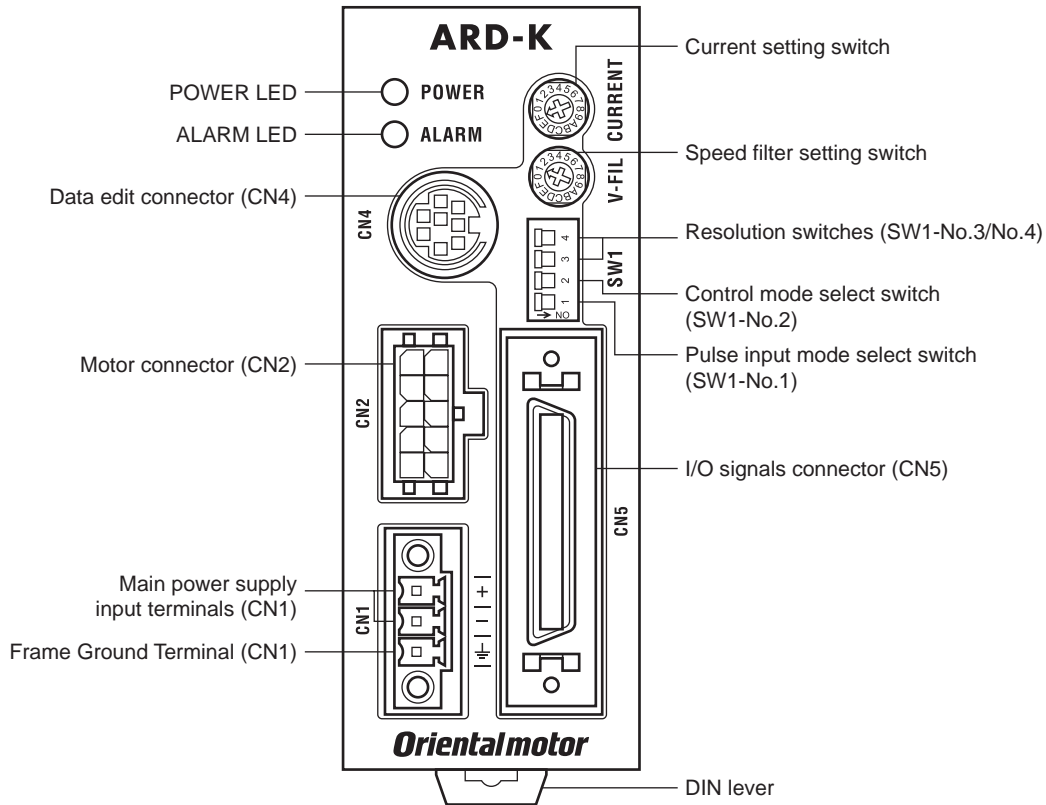

Name	Description	Ref.
POWER LED (Green)	This LED is lit while the main power is input.	-
ALARM LED (Red)	This LED will blink when an alarm generates. It is possible to check the generated alarm by counting the number of times the LED blinks.	p.53
Main power supply input terminals (CN1)	Connect the main power supply.	p.29
Frame Ground Terminal (CN1)	Ground using a wire of AWG24 to 16 (0.2 to 1.25 mm ²).	
Motor connector (CN2)	Connect the motor.	p.21
Data edit connector (CN4)	Connect a PC in which the data editing software MEXE02 has been installed, or the data setter OPX-2A .	p.30
I/O signals connector (CN5)	Connect the I/O signals of the controller.	p.23
Current setting switch (CURRENT)	This switch adjusts the operating current. It is used to limit the torque and temperature rise. A desired current can be set as a percentage (%) of the rated output current. Factory setting: F	p.41 p.50
Speed filter setting switch (V-FIL)	This switch adjusts the motor response. Use this switch if you want to suppress motor vibration or cause the motor to start/stop smoothly. "0" and "F" correspond to the minimum and maximum speed filter settings, respectively. Factory setting: 1	p.41 p.51
Pulse input mode select switch (SW1-No.1)	This switch is used to toggle between the 1-pulse input mode and 2-pulse input mode according to the pulse output mode of the controller. ON: 1-pulse input mode, low active OFF: 2-pulse input mode, low active The factory setting of the pulse-input mode depends on the destination country.	p.40 p.44
Control mode select switch (SW1-No.2)	This switch toggles the driver between the normal mode and current control mode. OFF: Normal mode (Keep the switch in this position in normal conditions of use.) ON: Current control mode (Set the switch to this position if you want to suppress noise or vibration.) Factory setting: OFF (Normal mode).	p.50
Resolution switches (SW1-No.3/No.4)	These two switches are used to set the resolution per revolution of the motor output shaft. Factory setting: OFF for No.3 and No.4 (1000 P/R).	p.40 p.43
DIN lever	Install the driver to a DIN rail	p.18

7 Installation

This chapter explains the installation location and installation methods of the motor and driver. The installation and wiring methods in compliance with the EMC Directive are also explained.

7.1 Location for installation

The motor and driver has been designed and manufactured to be installed within another device. Install them in a well-ventilated location that provides easy access for inspection.

The location must also satisfy the following conditions:

- Inside an enclosure that is installed indoors (provide vent holes)
- Operating ambient temperature
 - Motor: -10 to $+50$ °C (non-freezing)
 - Harmonic geared type: 0 to $+40$ °C (non-freezing)
 - Driver: 0 to $+50$ °C (non-freezing)
- Operating ambient humidity 85% or less (non-condensing)
- Area that is free of explosive atmosphere or toxic gas (such as sulfuric gas) or liquid
- Area not exposed to direct sun
- Area free of excessive amount of dust, iron particles or the like
- Area not subject to splashing water (rain, water droplets), oil (oil droplets) or other liquids
- Area free of excessive salt
- Area not subject to continuous vibration or excessive shocks
- Area free of excessive electromagnetic noise (from welders, power machinery, etc.)
- Area free of radioactive materials, magnetic fields or vacuum
- 1000 m (3300 ft.) or lower above sea level

7.2 Installing the motor

The motor can be installed in any direction.

To allow for heat dissipation and prevent vibration, install the motor on a metal surface of sufficient strength.

Installation method A

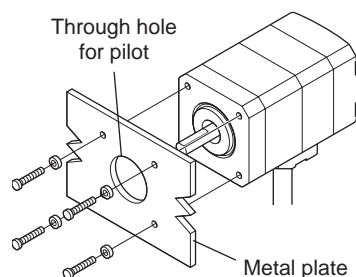

Installation method B

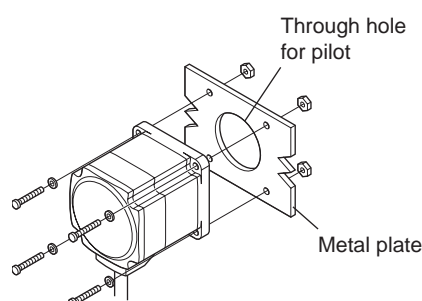

Type	Frame size [mm (in.)]	Nominal size	Tightening torque [N·m (oz-in)]	Effective depth of bolt [mm (in.)]	Installation method
Standard	28 (1.10)	M2.5	0.5 (71)	2.5 (0.098)	A
	42 (1.65)	M3	1 (142)	4.5 (0.177)	
	60 (2.36)	M4	2 (280)	-	B
	85 (3.35)	M6	3 (420)	-	
TH geared	28 (1.10)	M2.5	0.5 (71)	4 (0.157)	A
	42 (1.65)	M4	2 (280)	8 (0.315)	
	60 (2.36)	M8	4 (560)	15 (0.591)	
PN geared PS geared Harmonic geared *1	28 (1.10)	M3	1 (142)	6 (0.236)	A
	30 (1.18)	M4	2 (280)	8 (0.315)	
	42 (1.65)	M5	2.5 (350)	10 (0.394)	
	60 (2.36)	M8	4 (560)	15 (0.591)	
Harmonic geared *2	90 (3.54)	M8	4 (560)	-	B

*1 **AR24**, **AR46** and **AR66** type only.

*2 **AR98** type only.

7.3 Installing a load

When connecting a load to the motor, align the centers of the motor output shaft and load shaft. Flexible couplings are available as accessories.

- Note**
- When coupling the load to the motor, pay attention to the centering of the shafts, belt tension, parallelism of the pulleys, and so on. Securely tighten the coupling and pulley set screws.
 - Be careful not to damage the output shaft or bearings when installing a coupling or pulley to the motor output shaft.
 - Do not modify or machine the motor output shaft. Doing so may damage the bearings and destroy the motor.
 - Do not apply strong force using hammer or other tools when removing the parallel key. Doing so may damage the motor output shaft and bearings (ball bearings).

■ Using a coupling

Align the centers of the motor output shaft and load shaft in a straight line.

■ Using a belt drive

Align the motor output shaft and load shaft in parallel with each other, and position both pulleys so that the line connecting their centers is at a right angle to the shafts.

■ Using a gear drive

Align the motor output shaft and gear shaft in parallel with each other, and let the gears mesh at the center of the tooth widths.

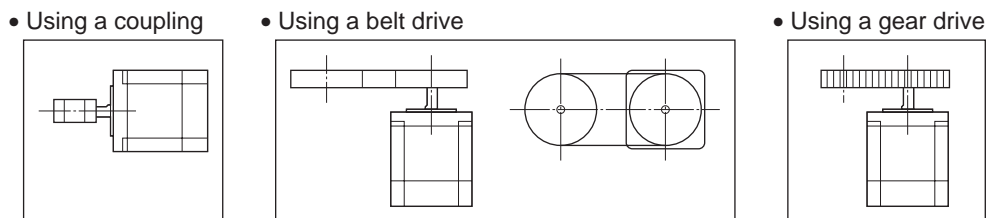

■ Using a parallel key (geared motor)

When connecting the load and gear output shaft with a key slot, secure the load using the key supplied with the gear output shaft after machining the key slot on the load.

■ Installing on the flange surface (Harmonic geared type)

With a Harmonic geared type (excluding AR98), a load can be installed directly to the gear using the load mounting holes provided on the flange surface.

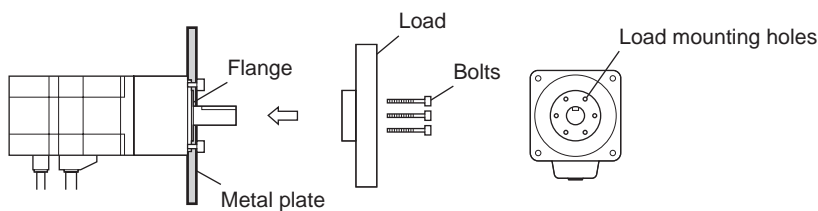

Model	Bolt size	Number of bolts	Tightening torque [N·m (oz-in)]	Effective depth of bolt [mm (in.)]
AR24	M3	4	1.4 (198)	4 (0.157)
AR46	M3	6	1.4 (198)	5 (0.197)
AR66	M4	6	2.5 (350)	6 (0.236)

- Note**
- When installing a load on the flange surface, the load cannot be mounted using the key slot in the output shaft.
 - Design an appropriate installation layout so that the load will not contact the metal plate or bolts used for installing the motor.

7.4 Permissible overhung load and permissible thrust load

Note

- If the overhung load or thrust load exceeds the specified allowable value, repeated load applications may cause the bearing (ball bearings) or output shaft of the motor to undergo a fatigue failure.
- With a double shaft type, do not apply load torque, overhung load or thrust load to the output shaft on the opposite side of the motor output shaft.

Type	Model	Gear ratio	Permissible overhung load [N (lb.)]					Permissible thrust load [N (lb.)]
			Distance from the tip of motor output shaft [mm (in.)]					
			0 (0)	5 (0.2)	10 (0.39)	15 (0.59)	20 (0.79)	
Standard	AR24	-	25 (5.6)	34 (7.6)	52 (11.7)	-	-	1.5 (0.33)
	AR26							2.2 (0.49)
	AR46		35 (7.8)	44 (9.9)	58 (13)	85 (19.1)	-	4.6 (1.03) <6.1 (1.37)> *
	AR66		90 (20)	100 (22)	130 (29)	180 (40)	270 (60)	8.8 (1.98) <11.8 (2.6)> *
	AR69							13.7 (3) <16.7 (3.7)> *
	AR98		260 (58)	290 (65)	340 (76)	390 (87)	480 (108)	18 (4) <24 (5.4)> *
TH geared	AR24	-	15 (3.3)	17 (3.8)	20 (4.5)	23 (5.1)	-	10 (2.2)
	AR46		10 (2.2)	14 (3.1)	20 (4.5)	30 (6.7)	-	15 (3.3)
	AR66		70 (15.7)	80 (18)	100 (22)	120 (27)	150 (33)	40 (9)
	AR98		220 (49)	250 (56)	300 (67)	350 (78)	400 (90)	100 (22)
PS geared	AR24	-	45 (10.1)	60 (13.5)	80 (18)	100 (22)	-	20 (4.5)
	AR46	5	73 (16.4)	84 (18.9)	100 (22)	123 (27)	-	50 (11.2)
		7.2						
		10						
	AR66	25	109 (24)	127 (28)	150 (33)	184 (41)	-	100 (22)
		36						
		50						
	AR98	5	480 (108)	540 (121)	600 (135)	680 (153)	790 (177)	300 (67)
		7.2						
		10						
	AR98	25	850 (191)	940 (210)	1050 (230)	1190 (260)	1380 (310)	300 (67)
		36	930 (200)	1030 (230)	1150 (250)	1310 (290)	1520 (340)	
50		1050 (230)	1160 (260)	1300 (290)	1480 (330)	1710 (380)		
50		1050 (230)	1160 (260)	1300 (290)	1480 (330)	1710 (380)		
PN geared	AR24	-	45 (10.1)	60 (13.5)	80 (18)	100 (22)	-	20 (4.5)
	AR46	-	100 (22)	120 (27)	150 (33)	190 (42)	-	100 (22)
	AR66	5	200 (45)	220 (49)	250 (56)	280 (63)	320 (72)	
		7.2	250 (56)	270 (60)	300 (67)	340 (76)	390 (87)	
		10	250 (56)	270 (60)	300 (67)	340 (76)	390 (87)	
	AR66	25	330 (74)	360 (81)	400 (90)	450 (101)	520 (117)	100 (22)
		36						
		50						
	AR98	5	480 (108)	520 (117)	550 (123)	580 (130)	620 (139)	300 (67)
		7.2	480 (108)	540 (121)	600 (135)	680 (153)	790 (177)	
		10	480 (108)	540 (121)	600 (135)	680 (153)	790 (177)	
		25	850 (191)	940 (210)	1050 (230)	1110 (240)	1190 (260)	
36		930 (200)	1030 (230)	1150 (250)	1220 (270)	1300 (290)		
50	1050 (230)	1160 (260)	1300 (290)	1380 (310)	1490 (330)			
Harmonic geared	AR24	-	110 (24)	135 (30)	175 (39)	250 (56)	-	140 (31)
	AR46		180 (40)	220 (49)	270 (60)	360 (81)	510 (114)	220 (49)
	AR66		320 (72)	370 (83)	440 (99)	550 (123)	720 (162)	450 (101)
	AR98		1090 (240)	1150 (250)	1230 (270)	1310 (290)	1410 (310)	1300 (290)

* The brackets < > indicate the value for the electromagnetic brake type.

■ Permissible moment load of the Harmonic geared type

When installing an arm or table on the flange surface, calculate the moment load using the formula below if the flange surface receives any eccentric load. The moment load should not exceed the permissible value specified in the table.

Moment load: $M [N \cdot m (oz \cdot in)] = F \times L$

Model	Permissible moment load [N·m (oz·in)]
AR24	2.9 (410)
AR46	5.6 (790)
AR66	11.6 (1640)

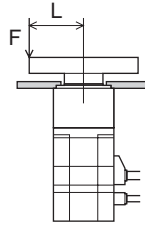

7.5 Installing the driver

Mount the driver to a 35 mm (1.38 in.) width DIN rail.

When two or more drivers are to be installed side by side, provide 10 mm (0.39 in.) and 50 mm (1.97 in.) clearances in the horizontal and vertical directions, respectively.

Note

- Install the driver in an enclosure whose pollution degree is 2 or better environment, or whose degree of protection is IP54 minimum.
- Do not install any equipment that generates a large amount of heat or noise near the driver.
- Do not install the driver underneath the controller or other equipment vulnerable to heat.
- Check ventilation if the ambient temperature of the driver exceeds 50 °C (122 °F).
- Be sure to install the driver vertically (vertical position).

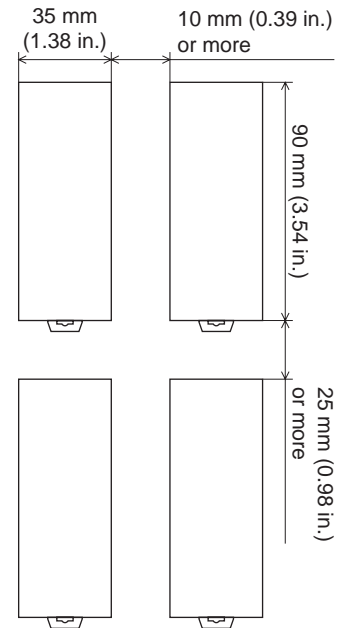

Pull down the driver's DIN lever and lock it. Hang the hook at the rear to the DIN rail, and push in the driver. After installation, secure the both sides of the driver with the end plate.

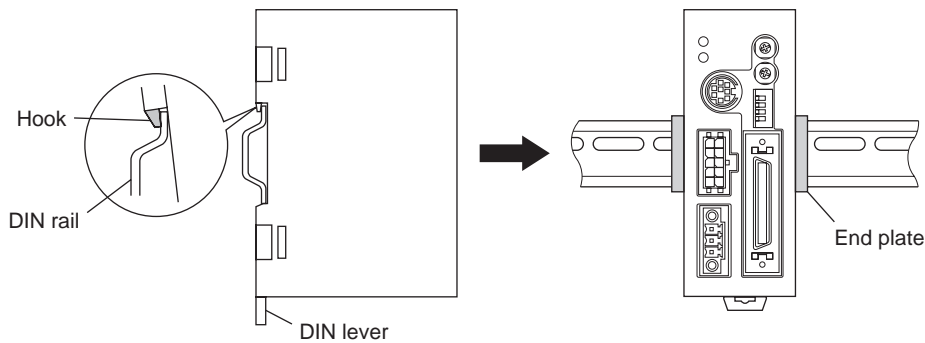

Removing from DIN rail

Pull the DIN lever down until it locks using a flat tip screwdriver, and lift the bottom of the driver to remove it from the rail. Use force of about 10 to 20 N (2.2 to 4.5 lb.) to pull the DIN lever to lock it. Excessive force may damage the DIN lever.

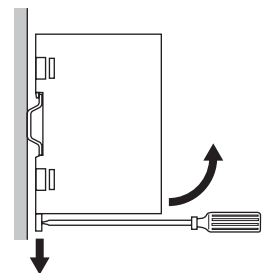

7.6 Installing and wiring in compliance with EMC Directive

Effective measures must be taken against the EMI that the motor and driver may give to adjacent control-system equipment, as well as the EMS of the motor and driver itself, in order to prevent a serious functional impediment in the machinery. The use of the following installation and wiring methods will enable the motor and driver to be compliant with the EMC directive. Refer to "CE Marking" on page.8 for the applicable standards.

■ Connecting noise filter for power supply line

- Connect a noise filter in the DC power supply input to prevent the noise generated in the driver from propagating externally through the power supply line.
- When using a power supply transformer, be sure to connect a noise filter to the AC input side of the power supply transformer.

Manufacturer	Model
SOSHIN ELECTRIC CO.,LTD	HF2010A-UPF
Schaffner EMC	FN2070-10-06

- Install the noise filter as close to the AC input terminal of DC power supply as possible. Use cable clamps and other means to secure the AC input cables (AWG18: 0.75 mm² or more) and output cables (AWG18: 0.75 mm² or more) firmly to the surface of the enclosure.
- Connect the ground terminal of the noise filter to the grounding point, using as thick and short a wire as possible.
- Do not place the AC input cable parallel with the noise filter output cable. Parallel placement will reduce noise filter effectiveness if the enclosure's internal noise is directly coupled to the power supply cable by means of stray capacitance.

■ Connecting the main power supply

Use a DC power supply compliant with the EMC Directive.

Use a shielded cable for wiring and wire/ground the power supply over the shortest possible distance.

Refer to "Wiring the power supply cable and signal cable" below for how to ground the shielded cable.

■ How to ground

The cable used to ground the driver and noise filter must be as thick and short as possible so that no potential difference is generated. Choose a large, thick and uniformly conductive surface for the grounding point.

• How to ground the driver

See page 29 for grounding the driver.

• How to ground the motor

When grounding the motor, use a protective earth.

For the grounding method, refer to the **AR** Series Motor [OPERATING MANUAL](#).

■ Wiring the power supply cable and signal cable

Use a shielded cable of AWG28 (0.08 mm²) or more for the power supply cable, and keep it as short as possible.

An accessory driver cable is available (sold separately). Refer to page 61.

To ground a shielded cable, use a metal cable clamp or similar device that will maintain contact with the entire circumference of the cable. Attach a cable clamp as close to the end of the cable as possible, and connect it as shown in the figure.

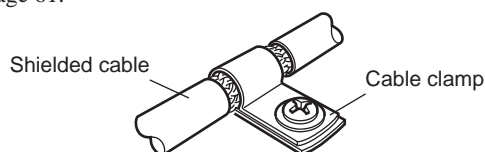

■ Notes about installation and wiring

- Connect the motor, driver and other peripheral control equipment directly to the grounding point so as to prevent a potential difference from developing between grounds.
- When relays or electromagnetic switches are used together with the system, use noise filters and CR circuits to suppress surges generated by them.
- Keep cables as short as possible without coiling and bundling extra lengths.
- Place the power cables such as the motor and power supply cables as far apart [100 to 200 mm (3.94 to 7.87 in.)] as possible from the signal cables. If the power cables and signal cables have to cross, cross them at a right angle. Place the AC input cable and output cable of a noise filter separately from each other.
- When extending the distance between the motor and driver, it is recommended that an accessory motor cable or flexible motor cable (sold separately) should be used. The EMC measures are conducted using the Oriental Motor extension cable.

■ Example of motor and driver installation and wiring

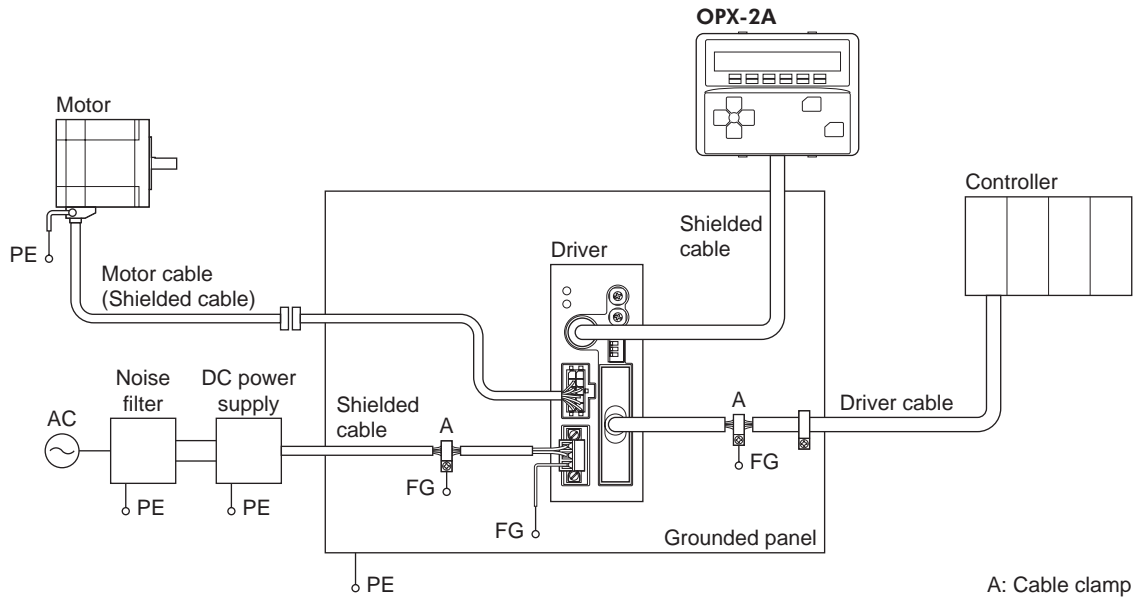

■ Precautions about static electricity

Static electricity may cause the driver to malfunction or suffer damage. While the driver is receiving power, handle the driver with care and do not come near or touch the driver.

Always use an insulated screwdriver to adjust the driver's switches.

Note The driver uses parts that are sensitive to electrostatic charge. Before touching the driver, turn off the power to prevent electrostatic charge from generating. If an electrostatic charge is impressed on the driver, the driver may be damaged.

8 Connection

This chapter explains how to connect the motor, I/O signals and power supply to the driver, as well as grounding method.

8.1 Connecting the motor

Connect the motor to the driver.

1. Connect the "motor cable" and supplied "cable for motor".
2. Connect the "cable for motor" to the motor connector (CN2) on the driver.

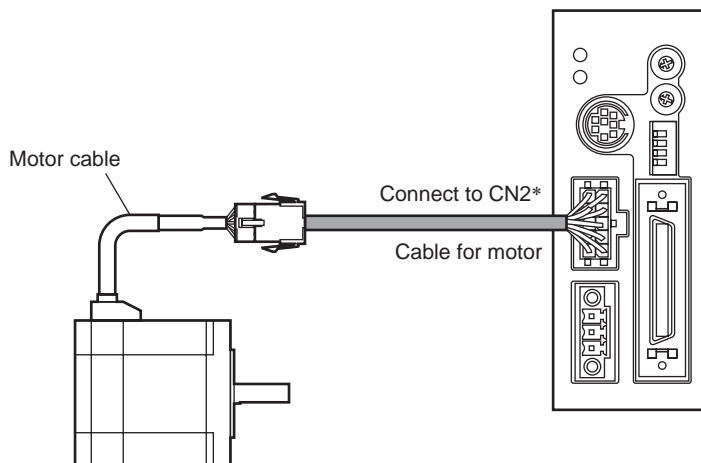

* Keep 30 m (98.4 ft.) or less for the wiring distance between the motor and driver.

Note

- Have the connector plugged in securely. Insecure connector connection may cause malfunction or damage to the motor or driver.
- When unplugging the connector, do so while pressing the latches on the connector.
- When plugging/unplugging the connector, turn off the power and wait for the POWER LED to turn off before doing so.
- When installing the motor to a moving part, use an accessory flexible cable offering excellent flexibility. For the flexible motor cable, refer to page 59..

8.2 Connecting the electromagnetic brake motor

Connect the motor to driver, and electromagnetic brake to the DC power supply.

1. Connect the "motor cable" and supplied "cable for motor".
2. Connect the "cable for motor" to the motor connector (CN2) on the driver.
3. Connect the "electromagnetic brake cable" and supplied "cable for electromagnetic brake".
4. Connect the surge suppressor (supplied with the motor) in parallel between the +24 VDC terminal of the DC power supply and the ground terminal.
The surge suppressor does not have polarity.
5. Connect the lead wires of the "cable for electromagnetic brake" to the DC power supply.
Connect the white lead wire to +24 VDC terminal, and the black lead wire to GND terminal.

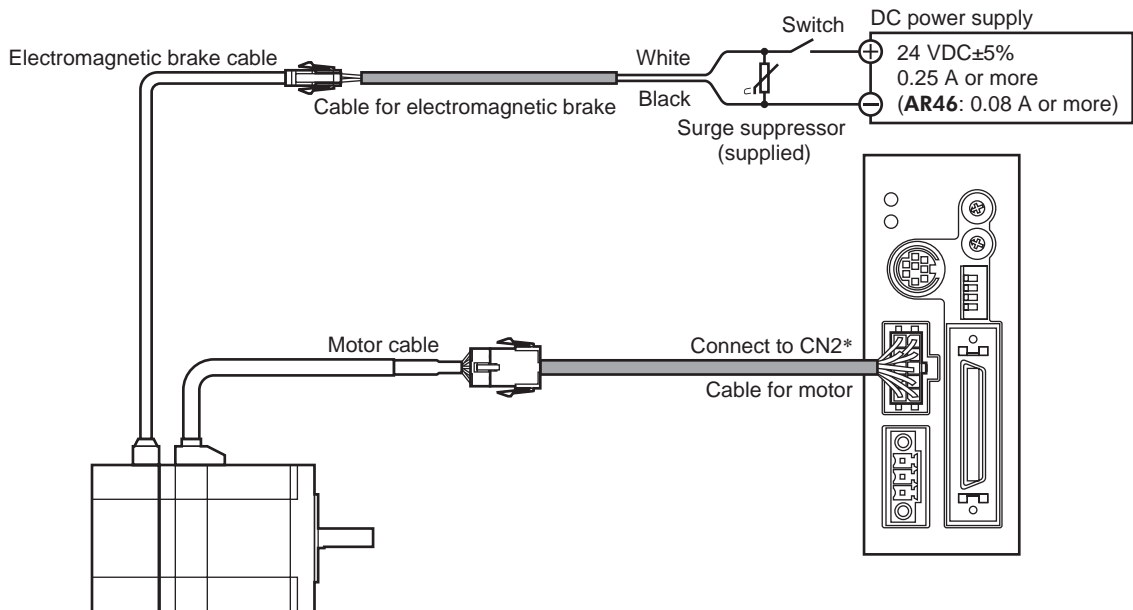

* Keep 30 m (98.4 ft.) or less for the wiring distance between the motor and driver.

Note

- The lead wires of the "cable for electromagnetic brake" have polarities, so connect them in the correct polarities. If the lead wires are connected with their polarities reversed, the electromagnetic brake will not operate properly.
- If the distance between the motor and driver is extended to 20 m (65.6 ft.) or longer, use a power supply of $24 \pm 4\%$ VDC.
- Have the connector plugged in securely. Insecure connector connection may cause malfunction or damage to the motor or driver.
- When unplugging the connector, do so while pressing the latches on the connector.
- When plugging/unplugging the connector, turn off the power and wait for the POWER LED to turn off before doing so.
- When installing the motor to a moving part, use a flexible cable offering excellent flexibility. See page 59.

8.3 Connecting the I/O signals

Solder the I/O signal cable (AWG28 to 24: 0.08 to 0.2 mm²) to the CN5 connector (36 pins) while checking the pin numbers in "Connector function table" provided below.

Use a shielded cable for I/O signals.

We provide an accessory driver cable allowing simple and easy connection with a driver, as well as connector-terminal block conversion unit. Refer to page 61 for details.

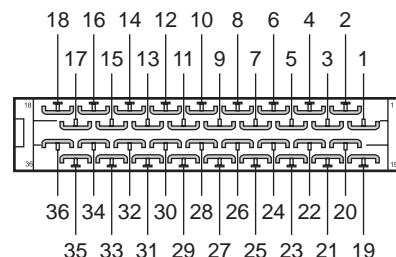

■ Connector function table

Pin No	Operating mode		Name		Ref.
	Positioning operation	Push-motion operation *1	Positioning operation	Push-motion operation *1	
1	-		-		-
2	GND		Ground connection		-
3	ASG+		A-phase pulse output (Line driver)		p.38
4	ASG-				
5	BSG+		B-phase pulse output (Line driver)		p.38
6	BSG-				
7	TIM1+		Timing output (Line driver)		p.38
8	TIM1-				
9	ALM+		Alarm output		p.39
10	ALM-				
11	WNG+		Warning output		p.39
12	WNG-				
13	END+		Positioning completion output		p.37
14	END-				
15	READY+/AL0+ *1		Operation ready complete output/Alarm code output 0		p.37
16	READY-/AL0- *1				
17	TLC+/AL1+ *1		Torque limit output/Alarm code output 1		p.37
18	TLC-/AL1- *1				
19	TIM2+/AL2+ *1		Timing output (Open collector)/Alarm code output 2		p.38
20	TIM2-/AL2- *1				
21	GND		Ground connection		-
22	IN-COM		Input common		-
23	C-ON *2		Current ON input		p.33
24	CLR/ALM-RST		Deviation clear input/Alarm reset input		p.36
25	CCM		Current control mode ON input		p.36
26	CS	T-MODE *1	Resolution selection input	Push-motion operation ON	p.34
27	-	M0 *1	-	Push-current setting selection input	p.36
28	RETURN	M1 *1	Return to electrical home operation		p.35
29	P-RESET	M2 *1	Position reset input		p.35
30	FREE		Excitation OFF		p.34
31	CW+/PLS+		CW pulse input/Pulse input (+5 V or line driver)		p.33
32	CW-/PLS-				
33	CW+24 V/PLS+24 V		CW pulse input/Pulse input (+24 V)		
34	CCW+24 V/DIR+24 V		CCW pulse input/Direction input (+24 V)		
35	CCW+/DIR+		CCW pulse input/Direction input (+5 V or line driver)		
36	CCW-/DIR-				

*1 The signal will become effective if the applicable setting has been changed using the **OPX-2A** or **MEXE02**.

*2 Factory setting of the C-ON input logic is "normally open." Be sure to turn the C-ON input ON when operating the motor. Set the C-ON input logic to "normally closed" when the C-ON input is not used.

■ Assembling the connector

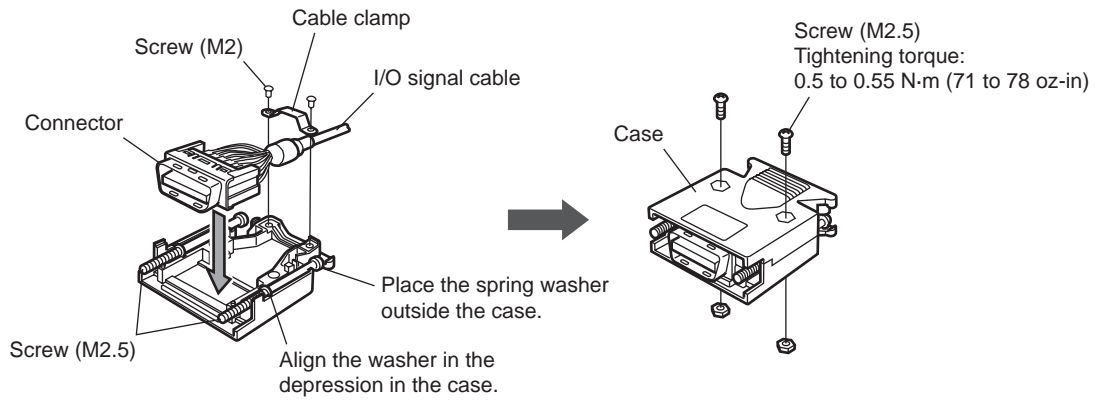

■ Connecting the connector

Insert the CN5 connector into the I/O signals connector (CN5) on the driver, and tighten the screw.
Tightening torque: 0.3 to 0.35 N·m (42 to 49 oz-in)

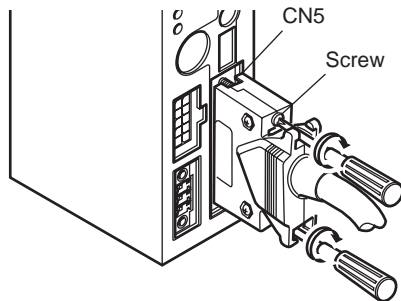

Note Be certain the I/O signals cable is as short as possible. The maximum input frequency will decrease as the cable length increases.

■ Connecting to a current sink output circuit

- When pulse input is of line driver type

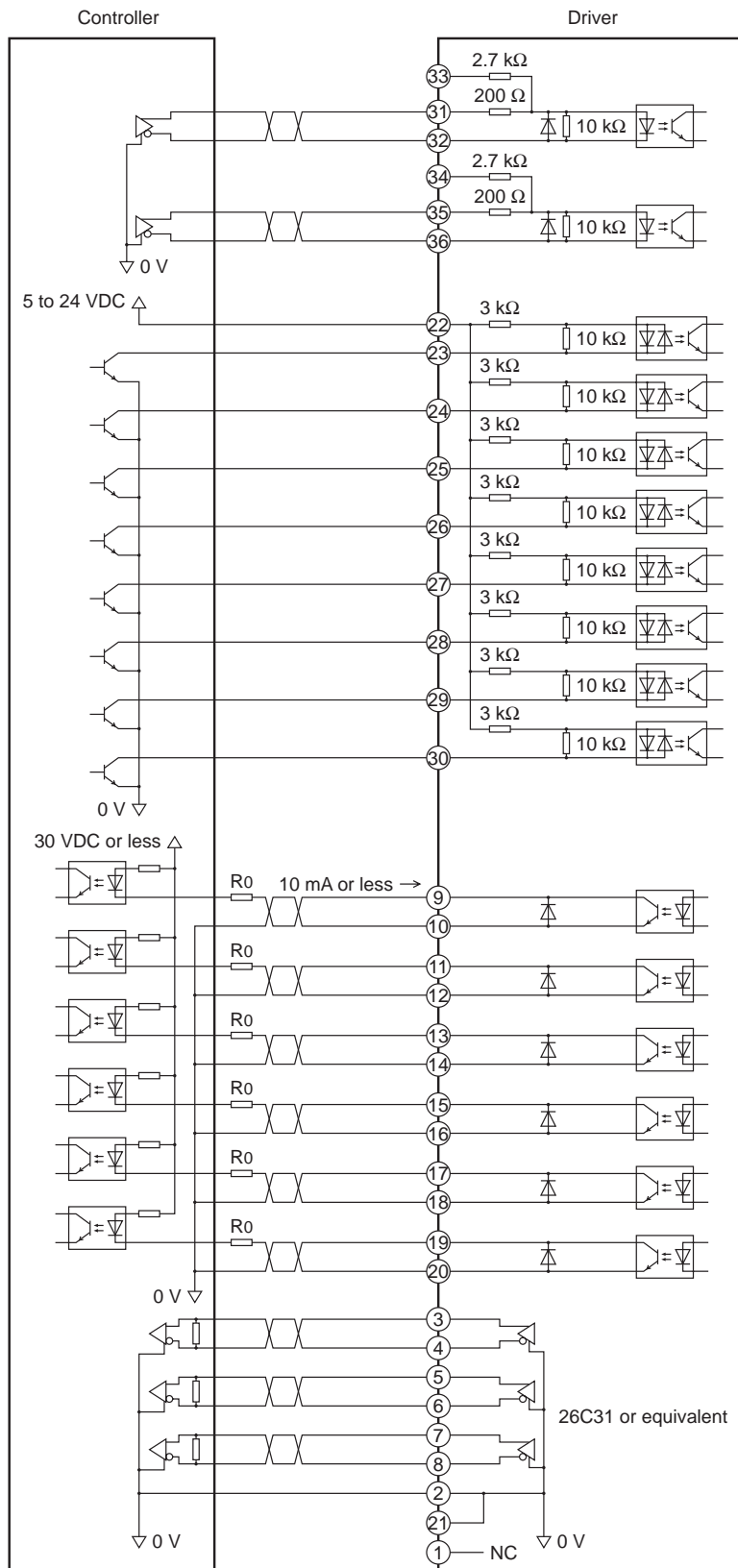

- Note**
- Use output signals at 30 VDC or less. If the current exceeds 10 mA, connect an external resistor R0.
 - Connect a termination resistor of 100 Ω or more between the driver and the input of the line receiver.

- When pulse input is of 5 VDC type

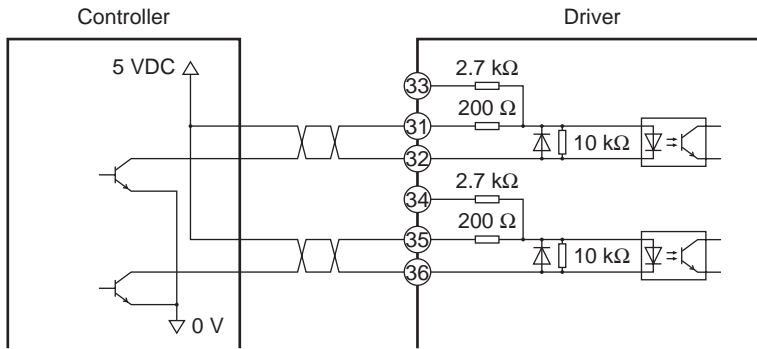

- When pulse input is of 24 VDC type

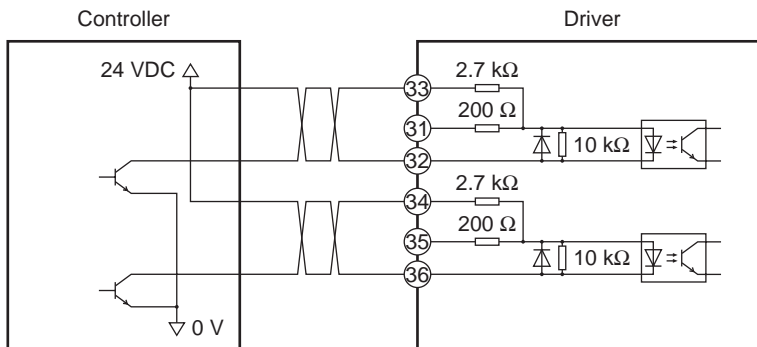

■ Connecting to a current source output circuit

- When pulse input is of line driver type

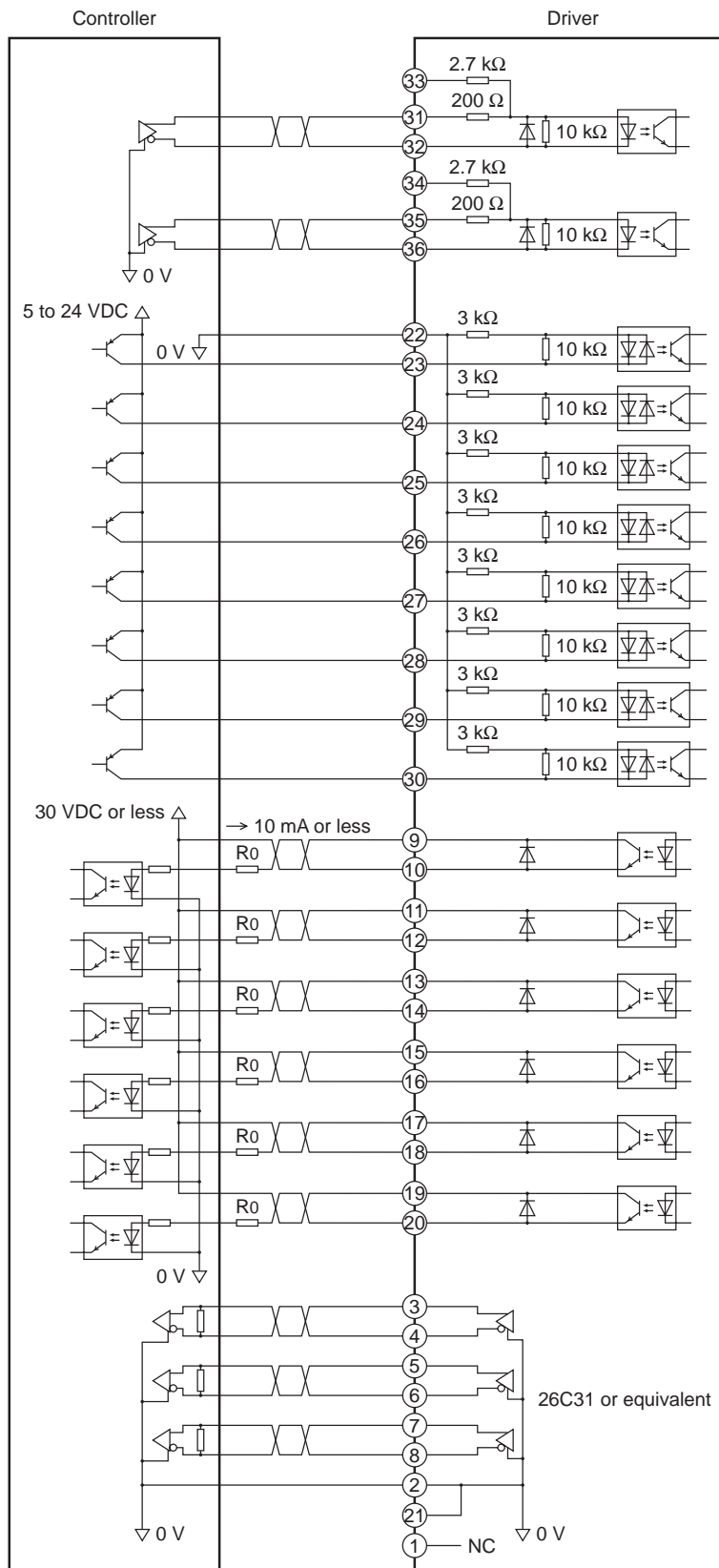

- Note**
- Use output signals at 30 VDC or less. If the current exceeds 10 mA, connect an external resistor R0.
 - Connect a termination resistor of 100 Ω or more between the driver and the input of the line receiver.

- When pulse input is of 5 VDC type

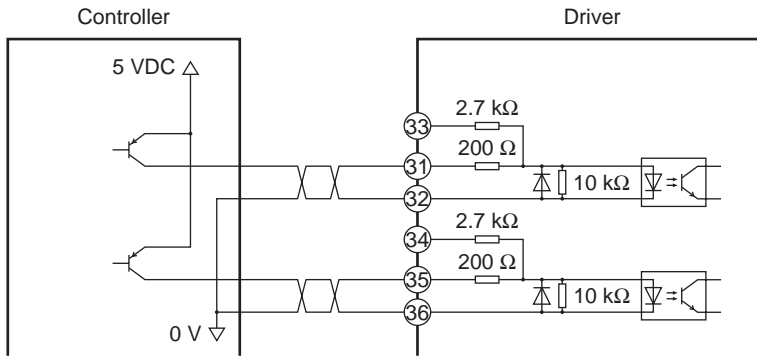

- When pulse input is of 24 VDC type

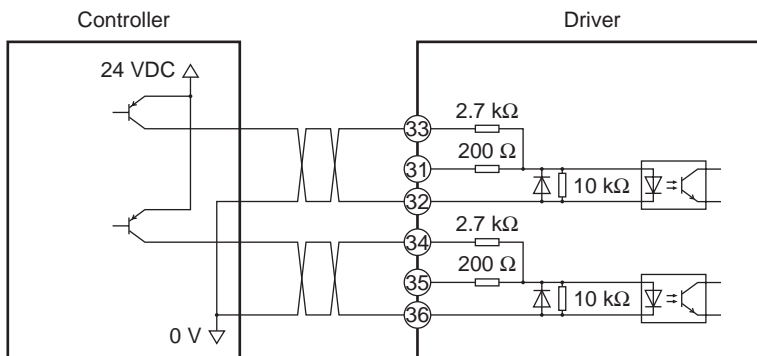

8.4 Connecting the power supply and grounding the driver

■ Connecting the power supply

Use the CN1 connector (3 pins) to connect the power supply cable (AWG24 to 16: 0.2 to 1.25 mm²) to the main power supply input connector (CN1) on the driver.

Use a power supply that can supply the current capacity show in the table to the right.

Model	Power supply input voltage	Power supply current capacity
AR24 AR26	24 VDC±10%	0.9 A or more
AR46	24 VDC±10% 48 VDC±5%	1.4 A or more
AR66		3.1 A or more
AR69		3.0 A or more
AR98		2.5 A or more

Note

- Pay attention to the polarity of the power supply. Reverse-polarity connection may cause damage to the driver.
- Do not wire the power supply cable of the driver in the same cable duct with other power line or motor cable. Doing so may cause malfunction due to noise.
- When cycle the power or plugging/unplugging the connector, turn off the power and wait for the POWER LED to turn off.

■ Grounding the driver

Ground the frame ground terminal (FG) of driver as necessary.

Ground using a wire of AWG24 to 16 (0.2 to 1.25 mm²), and do not share the protective earth terminal with a welder or any other power equipment.

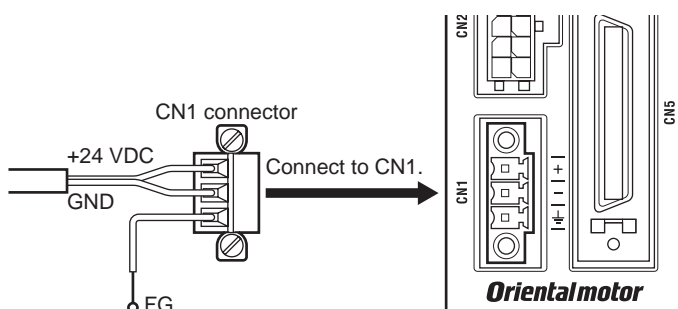

■ Connecting method

1. Strip the insulation cover of the lead wire by 7 mm (0.28 in.)
2. Insert each lead wire into the CN1 connector and tighten the screw using a screwdriver (connector screw size: M2).
Tightening torque: 0.22 to 0.25 N·m (31 to 35 oz-in)
3. Insert the CN1 connector into CN1 on the driver and tighten the screws using a screwdriver (connector screw size: M2.5).
Tightening torque: 0.4 N·m (56 oz-in)

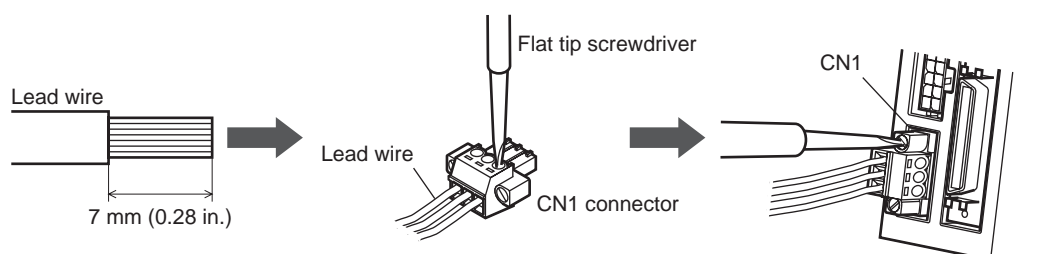

8.5 Connecting the data setter

Connect **OPX-2A** cable or supplied cable with the **MEXE02** to the data edit connector (CN4) on the driver.

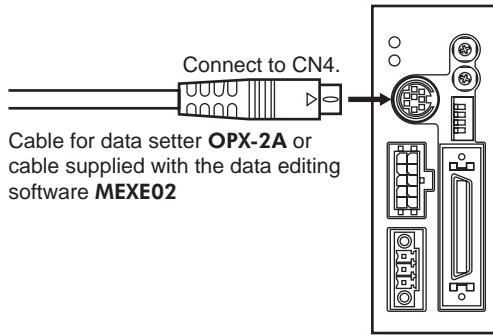

Caution The main power supply connector (CN1), data edit connector (CN4) and I/O signal connector (CN5) of the driver are not electrically insulated. When grounding the positive terminal of the power supply, do not connect any equipment (PC, etc.) whose negative terminal is grounded. Doing so may cause the driver and these equipment to short, damaging both.

9 Quick operations

If you are new to the **AR** Series driver, read this chapter and you will be able to perform basic motor operations quickly.

Note Before operating the motor, check the condition of the surrounding area to ensure safety.

STEP 1 Check the installation and connection

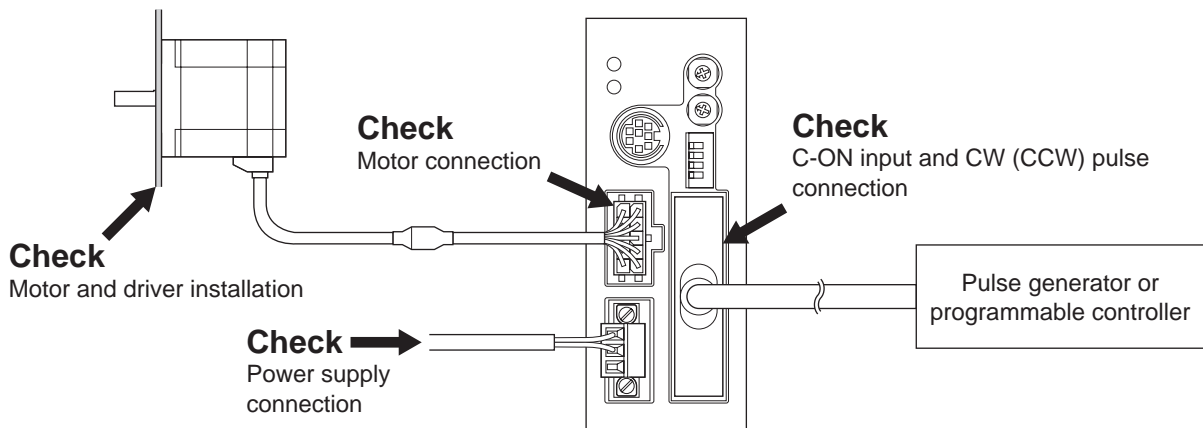

STEP 2 Operate the motor

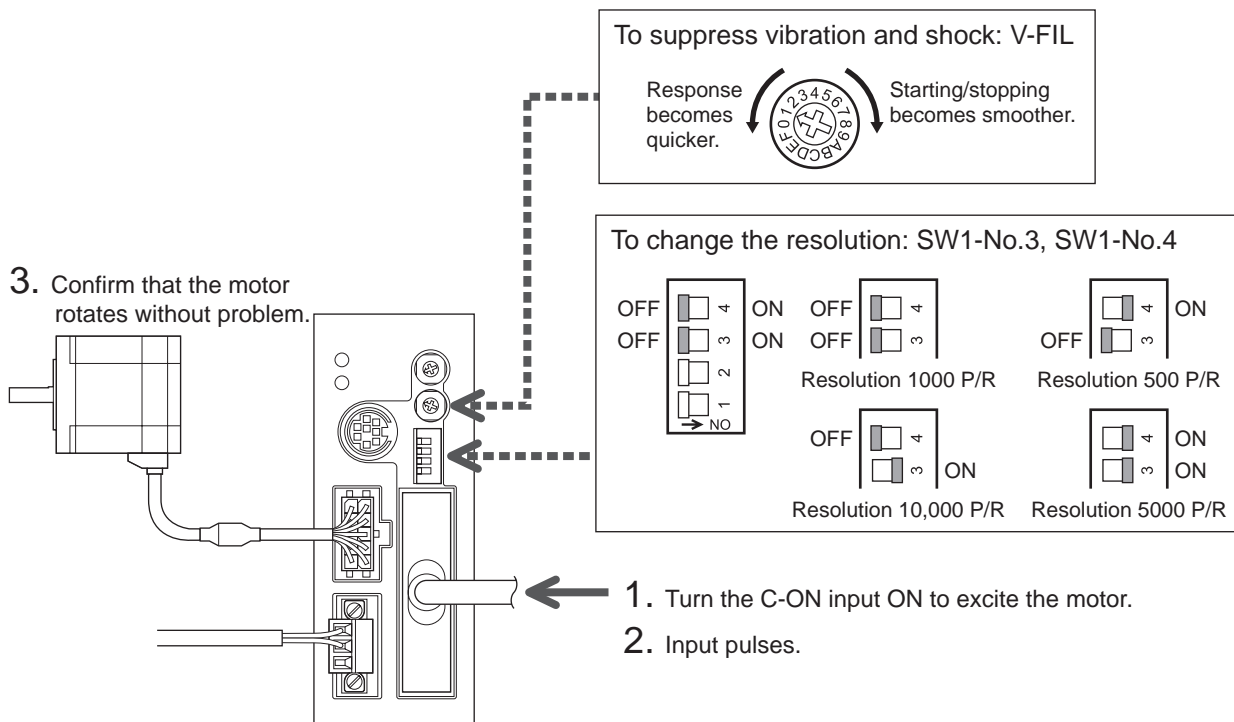

STEP 3 Were you able to operate the motor properly?

How did it go? Were you able to operate the motor properly? If the motor does not function, check the following points:

- Is the C-ON input ON?
- Is any alarm present?
- Are the power supply and motor connected securely?

For more detailed settings and functions, refer to "12 Extended functions" on page.42.

10 Explanation of I/O signals

Check the timing charts in, page 62.

10.1 Input signals

The following input signals of the driver are photocoupler inputs. The signal state represents the "ON: Carrying current" or "OFF: Not carrying current" state of the internal photocoupler rather than the voltage level of the signal.

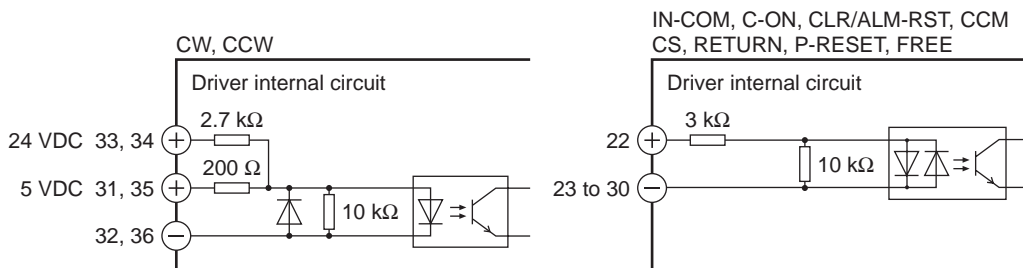

■ C-ON input

This signal is used to excite the motor (initial value: normally open).

When an electromagnetic brake motor is used, release the electromagnetic brake after the motor is excited.

With the **OPX-2A** or **MEXE02**, it is possible to set the C-ON input logic and the excitation position at the C-ON input ON.

Refer to page 46 for details.

Note The factory setting of the C-ON input is normally open. Be sure to turn the C-ON input ON when operating the motor. Set the C-ON input to normally closed when the C-ON input is not used.

■ CW/PLS input, CCW/DIR input

These input serve as the CW and CCW inputs in the 2-pulse input mode, or PLS and DIR inputs in the 1-pulse input mode. They are common to all pulse input types including 5 VDC input, 24 VDC input and line driver input.

Note

- When no pulse is input, be sure to keep the photocoupler in OFF state.
- The CW and CCW indicate the rotation direction of the motor, as seen from the output shaft. The output shaft of the **TH** geared typed motors with ratios of 20 and 30, as well as all ratios of the Harmonic geared type motors, rotate in the opposite direction of the motor shaft.

• 2-pulse input mode

When the CW input is turned ON, the motor will rotate by one step in CW direction.

When the CCW input is turned ON, the motor will rotate by one step in CCW direction.

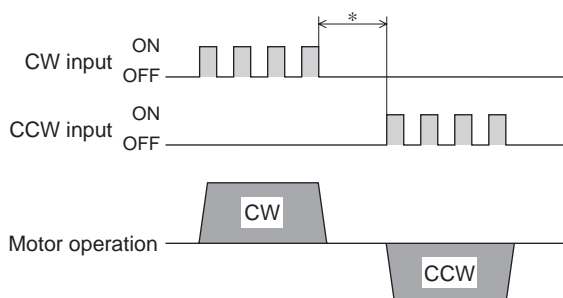

* The minimum interval time needed for switching the direction of rotation will vary, depending on the operating speed and size of the load. Do not shorten the interval time more than necessary.

Note While one pulse is input, the other pulse should always be turned OFF. If both pulses are turned ON simultaneously, no pulse will be input.

- 1-pulse input mode

When the PLS input is turned ON while the DIR input is ON, the motor will rotate by one step in CW direction.
 When the PLS input is turned ON while the DIR input is OFF, the motor will rotate by one step in CCW direction.

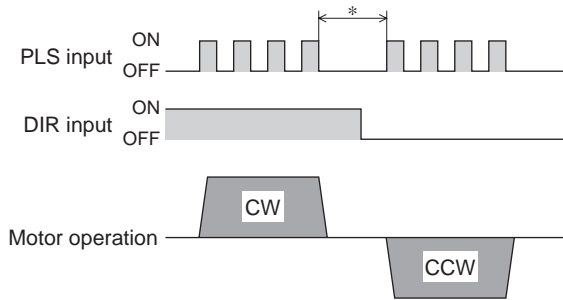

* The minimum interval time needed for switching the direction of rotation will vary, depending on the operating speed and size of the load. Do not shorten the interval time more than necessary.

- Pulse signal

Input a pulse with sharp rising and falling edges as shown in the figure. The figure shows the voltage levels of pulse signals.

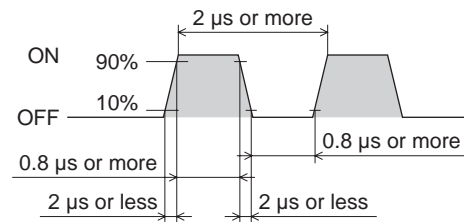

■ FREE input

When the FREE input is turned ON, current supplied to the motor will be cut off, thereby allowing the motor output shaft to be turned by external force.

When the FREE input is turned OFF, current will be supplied to excite the motor and the holding torque will be restored. The automatic return operation after turning the FREE input OFF can be set using the **OPX-2A** or **MEXE02**. Refer to page 46.

Note | When operating the motor, be sure to turn the FREE input OFF.

■ CS (T-MODE) input

The CS input is effective when positioning operation is performed.

When “push-motion operation” is selected with the **OPX-2A** or **MEXE02**, the T-MODE input will become effective.

- CS input

When the resolution switch (SW1-No.3) is set to OFF, the resolution setting can be changed according to the CS input.

Resolution switch	CS input OFF	CS input ON
SW1-No.3: OFF SW1-No.4: OFF	The setting of SW1-No.3 OFF is selected. Factory setting: 1000 P/R	The setting of SW1-No.3 ON is selected. Factory setting: 10000 P/R
SW1-No.3: OFF SW1-No.4: ON	The setting of SW1-No.3 OFF is selected. Factory setting: 500 P/R	The setting of SW1-No.3 ON is selected. Factory setting: 5000 P/R

Note | While the resolution switch (SW1-No.3) is set to ON, the CS input is disabled. The ON setting is maintained.

- T-MODE input

When the T-MODE input is turned ON, the push-motion operation will be started.

■ RETURN (M1) input

The RETURN input is effective when positioning operation is performed.

When “push-motion operation” is selected with the **OPX-2A** or **MEXE02**, the M1 input will become effective.

• RETURN input

When the RETURN input is turned ON, the motor will start a return to electrical home operation.

Return to electrical home operation is a type of operation that moves the motor to its electrical home position (where the cumulative value of command positions becomes “0”).

The electrical home position is initially at the motor position when the power is turned on and it can be changed to a desired position using the P-RESET input.

• M1 input

Combine this input with the M0 and M2 inputs to select a desired current setting for push-motion operation.

Refer to page 48 for the current setting for push-motion operation.

■ P-RESET (M2) input

The P-RESET input is effective when positioning operation is performed.

When “push-motion operation” is selected with the **OPX-2A** or **MEXE02**, the M2 input will become effective.

• P-RESET input

When the P-RESET input is turned ON, the cumulative value of command positions will become “0” and the electrical home position will be set. Input this signal while the motor is at standstill.

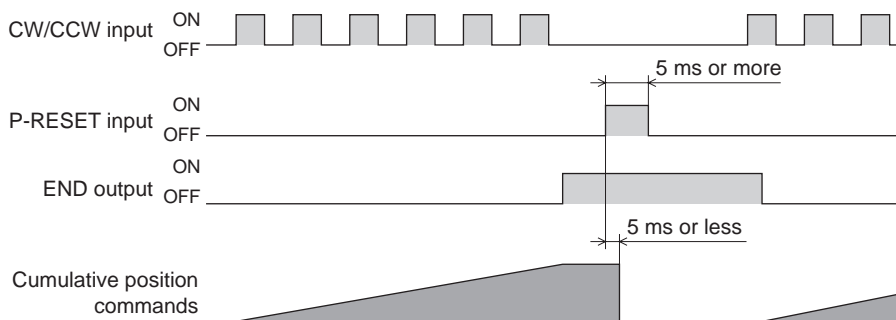

• M2 input

Combine this input with the M0 and M1 inputs to select a desired current setting for push-motion operation.

Refer to page 48 for the current setting for push-motion operation.

■ CLR/ALM-RST input

This input is used to clear the position deviation counter.

If an alarm generates, the CLR/ALM-RST input will function as an input signal to reset the alarm.

• CLR input

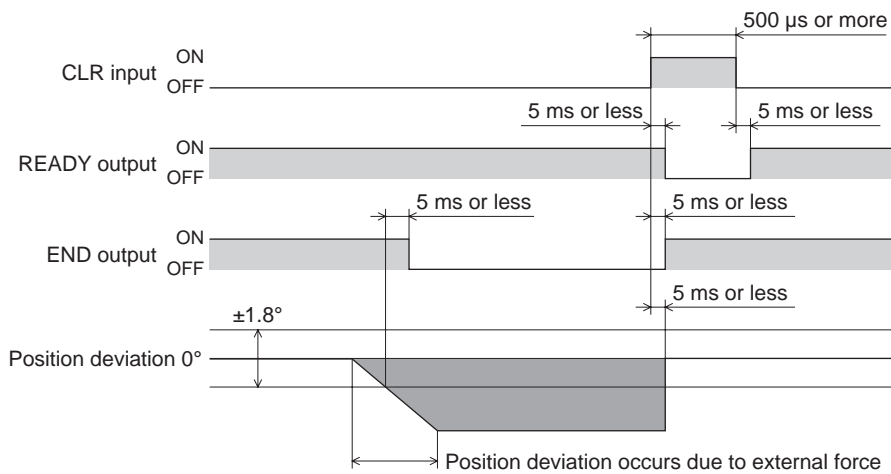

- Note**
- When performing a return to mechanical home operation using a stopper, etc., do not use the CLR input. If the CLR input is used, the home position may become offset.
 - Pulse input is disabled while the CLR input is ON.
 - When the CLR input is turned ON, the automatic return operation and return to electrical home operation will stop.

• ALM-RST input

When an alarm generates, the ALM output will turn OFF. When the ALM-RST input is turned from ON to OFF, the ALM output will turn ON and the alarm will be reset. (The alarm will be reset at the OFF edge of the ALM-RST input.) Before resetting an alarm, always remove the cause of the alarm and ensure safety.

For details, refer to "ALM output" on page.39, and "14.1 Alarms" on page.53.

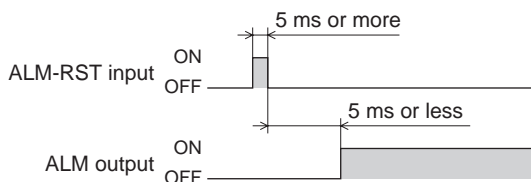

- Note** Alarms that cannot be reset with the ALM-RST input need to be reset by cycling the power. If a normal condition cannot be restored after cycling the power, contact your nearest Oriental Motor sales office.

■ CCM input

When the CCM input is turned ON, the control mode will change from the normal mode to the current control mode. In the current control mode, noise and vibration can be reduced although the motor synchronicity drops. Be sure to turn the CCM input ON/OFF after confirming that the motor has stopped.

- Note** Keep the control mode switch in the OFF (normal mode). If the switch is in the ON (current control mode), the CCM input will be disabled.

■ M0 input

When "push-motion operation" is set with the **OPX-2A** or **MEXE02**, the M0 input will become effective. Combine this input with the M1 and M2 inputs to select a desired current setting for push-motion operation. Refer to page 48 for the current setting for push-motion operation.

10.2 Output signals

The driver outputs signals in the photocoupler/open-collector output mode or line driver output mode. The signal state represents the "ON: Carrying current" or "OFF: Not carrying current" state of the internal photocoupler rather than the voltage level of the signal.

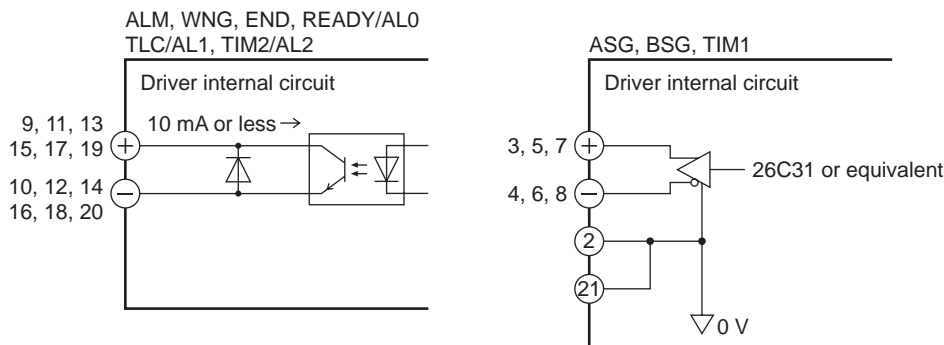

Note The ASG output, BSG output and TIM1 output are line driver outputs. When connecting a line driver output, receive the output signal using a line receiver. Also, be sure to connect pins 2 and 21 of the driver to the GND on the line receiver, and connect a termination resistor of 100 Ω or more between the driver and the input of the line receiver.

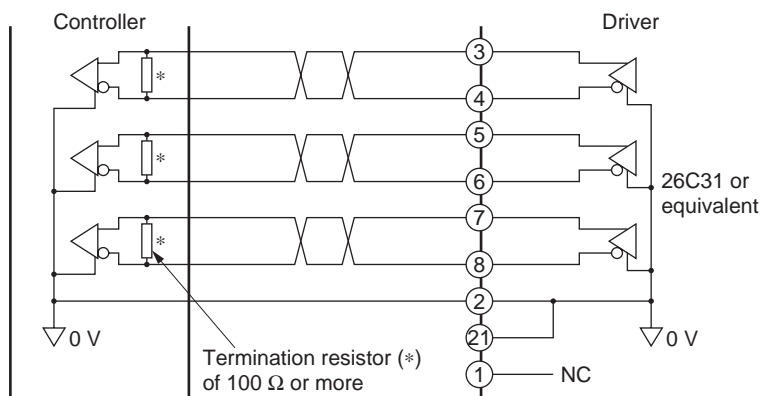

■ READY/AL0 output

When the driver becomes ready, the READY output turns ON. Input pulse signals to driver after the READY output has turned ON.

If an alarm generates, an alarm code indicating the cause of the alarm can be output and checked via the combination of AL0, AL1 and AL2 outputs. To use alarm codes, the applicable parameter must be changed using the **OPX-2A** or **MEXE02**. For details, refer to page 53.

■ TLC/AL1 output

This signal will be output when the torque characteristic exceeds the specified range. If a push current is set using an extended function, this signal is output while pushing.

If an alarm generates, an alarm code indicating the cause of the alarm can be output and checked via the combination of AL0, AL1 and AL2 outputs. To use alarm codes, the applicable parameter must be changed using the **OPX-2A** or **MEXE02**. For details, refer to page 53.

■ END output

When the motor has completed its movement, the END output will turn ON. Specifically, the END output will turn ON when the rotor position falls within $\pm 1.8^\circ$ of the command position while no pulse signal is input.

A desired output condition for the END signal can be set using the **OPX-2A** or **MEXE02**.

Refer to "18.2 Function/parameter list" on page.70.

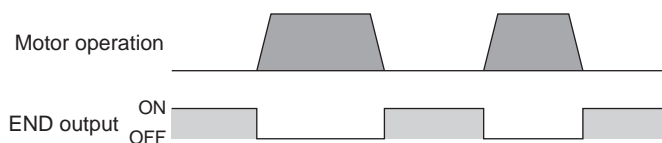

* The output time of the END signal varies depending on the position command filter and operating speed.

TIM1 output

The TIM output will turn ON every time the motor output shaft rotates by 7.2°.

Two types of TIM outputs are available: the line driver output (TIM1 output), and the open collector output (TIM2 output). Change the TIM output according to the pulse input mode of the programmable controller.

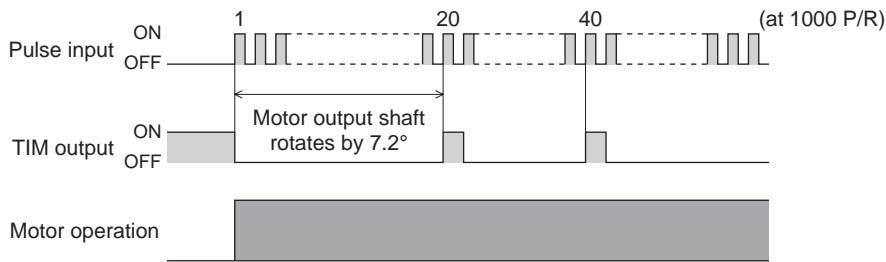

Note

- The TIM1 output will turn ON when the pulse speed is 10 kHz or less, and the TIM2 output will turn ON when the pulse speed is 500 Hz or less.
- When changing the resolution using the CS input, do so while the TIM output is ON and the motor is at standstill. If the CS input is turned ON/OFF when one or both of these conditions are unsatisfied, the TIM output will not turn ON even after the motor output shaft rotates by 7.2°.

TIM2/AL2 output

Refer to “TIM1 output” for the TIM2 output.

If an alarm generates, an alarm code indicating the cause of the alarm can be output and checked via the combination of AL0, AL1 and AL2 outputs. To use alarm codes, the applicable parameter must be changed using the **OPX-2A** or **MEXE02**. For details, refer to page 53.

ASG output, BSG output

The ASG output is used to output pulses according to motor operation. The motor position can be monitored by counting the ASG output pulses. The number of output pulses per motor revolution varies depending on the resolution effective when turning the power on.

The BSG output has a 90° phase difference with respect to the ASG output.

The motor rotation direction can be determined by detecting the BSG output level at the rise of the ASG output.

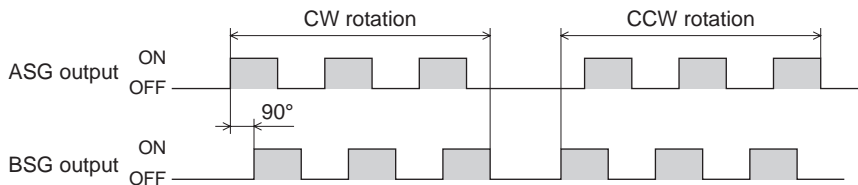

Note

- The ASG output and BSG output are subject to a maximum delay of 0.1 ms with respect to motor operation. Use these outputs to check the position at which the motor is stopped.
- Connect a termination resistor of 100 Ω or more between the driver and the input of the line receiver.

Electrical characteristics of ASG output and BSG output

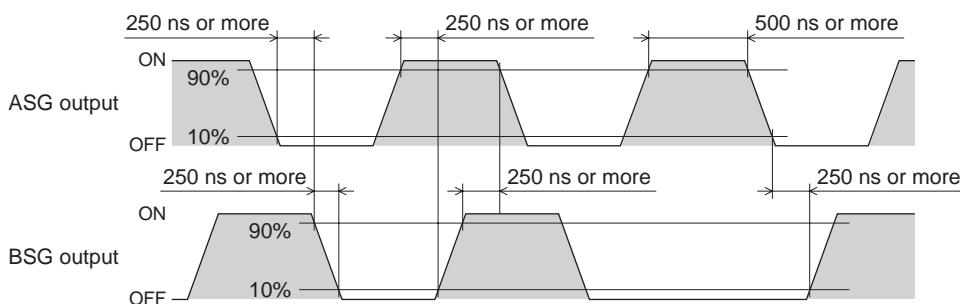

The electrical characteristics vary depending on the IC specification of the line driver.

■ WNG output

When a warning generates, the WNG output turns ON. The warning can be generated before a corresponding alarm generates.

To use the WNG output, the applicable parameter must be changed using the **OPX-2A** or **MEXE02**. (The initial value is to use the same conditions applicable to alarms.) For details, refer to page 56.

■ ALM output

When an alarm generates, the ALM output will turn OFF. At the same time, the ALARM LED of the driver will blink and the motor current will be cut off and stop. *

Set the programmable controller so that it will stop motor operation commands upon detection of an OFF status of the ALM output. The cause of the alarm can be checked by counting the number of times the ALARM LED blinks. For details, refer to page 53.

* Abnormal operation data alarm is not supported by this function (because the current will not be cut off even after these errors occur).

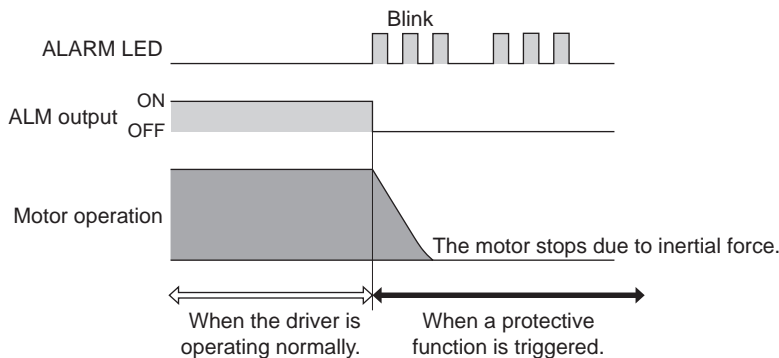

10.3 Timing chart

When turning the main power supply on and turning the C-ON input ON, the motor will be excited. The READY output will turn ON and pulse input will be enabled.

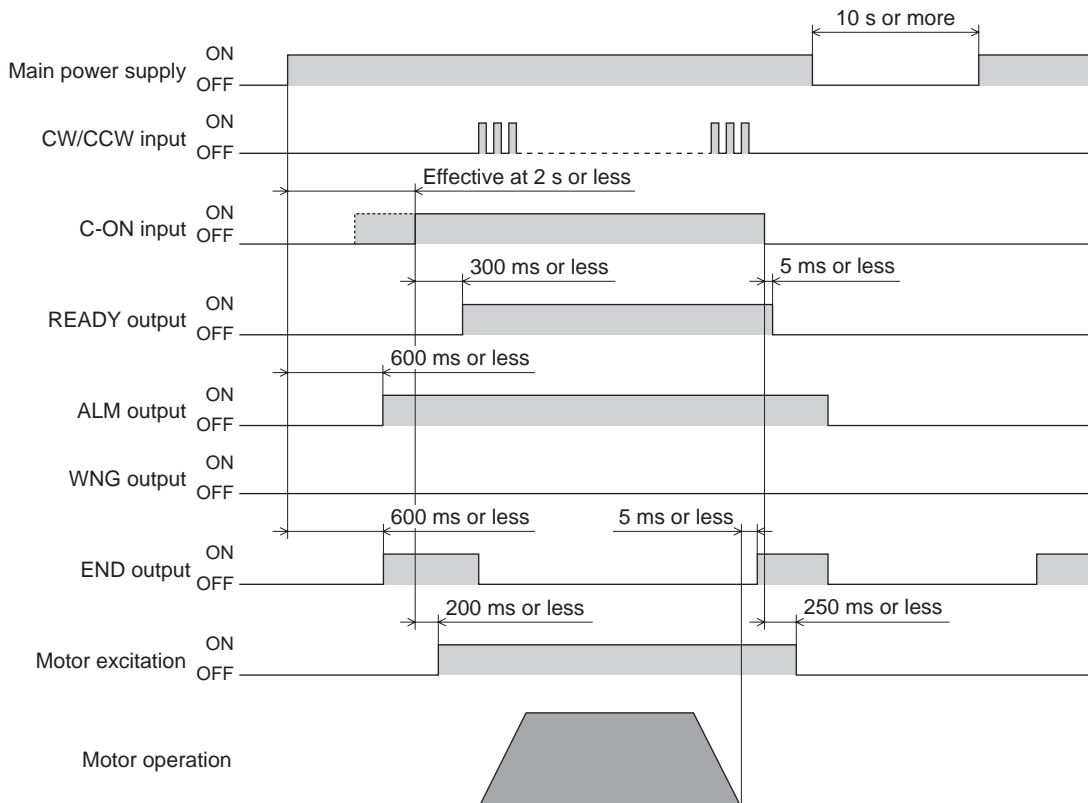

11 Setting

This chapter explains how to change and set the driver functions using the switches on the front face of the driver.

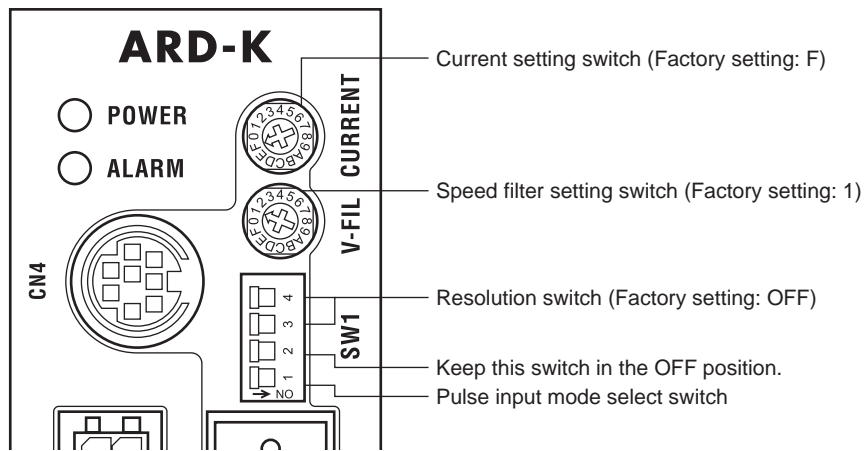

Note Before operating any switch, turn off the driver power and wait for the POWER LED to turn off.

11.1 Resolution

Use the resolution switches (SW1-No.3/No.4) to set a desired resolution per revolution of the motor output shaft.

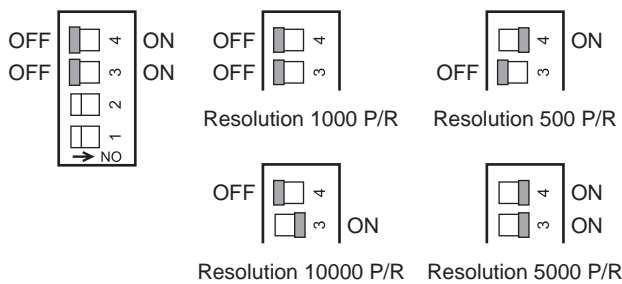

- Note**
- The new settings of the resolution switches will become effective after the power is cycled.
 - When changing the resolution using the CS input, use the switches in "No.3: OFF"/"No.4: OFF" or "No.3: OFF"/"No.4: ON" combination. If the CS input is turned ON when "No.3: ON" is selected, the resolution will not be changed.
- To change the basic resolution setting: Refer to page 43.

11.2 Pulse input mode

Set a desired pulse input mode of the driver according to the pulse output mode of the controller (pulse generator) used with the driver. Set a desired mode using the pulse input mode select switch (SW1-No.1).

OFF: 2-pulse input mode (when the CW input and CCW input are used)
 ON: 1-pulse input mode (when the PLS input and DIR input are used)

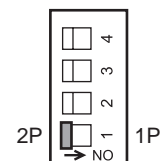

- Note**
- The new setting of the pulse input mode select switch will become effective after the power is cycled.
 - The factory setting of the pulse input mode depends on the destination country.
- To change the basic setting for pulse input mode: Refer to page 44.

11.3 Operating current

Set a desired operating current using the current setting switch (CURRENT).

The operating current to be set is the maximum output current multiplied by the operating current rate (%) set to each dial setting of the current setting switch, where “F” corresponds to 100%.

One of 16 operating current levels from 0 to F can be set.

If the load is small and there is an ample allowance for torque, motor temperature rise can be suppressed by setting a lower operating current.

The dial settings and corresponding operating current rates are listed below.

Dial setting	Operating current rate (%)	Dial setting	Operating current rate (%)	Dial setting	Operating current rate (%)
0	6.3	5	37.5	A	68.8
1	12.5	6	43.8	B	75.0
2	18.8	7	50.0	C	81.3
3	25.0	8	56.3	D	87.5
4	31.3	9	62.5	E	93.8
				F	100 (factory setting)

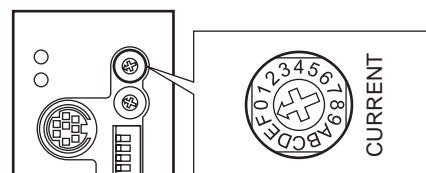

Note Excessively low operating current may cause a problem in starting the motor or holding the load in position. Do not lower the operating current more than necessary.

- To change the basic setting for operating current: Refer to page 50.

11.4 Speed filter

The motor response to input pulses can be adjusted with the speed filter setting switch (V-FIL).

One of 16 speed filter levels from 0 to F can be set.

When setting a higher value for the speed filter, lower vibration at low speed operation or smoother operation at starting/stopping of the motor can be achieved.

However, if this setting is too high, synchronization performance is decreased. Set a suitable value based on the load or application.

Dial setting	Speed filter time constant (ms)	Dial setting	Speed filter time constant (ms)
0	0	8	30
1	1 (factory setting)	9	50
2	2	A	70
3	3	B	100
4	5	C	120
5	7	D	150
6	10	E	170
7	20	F	200

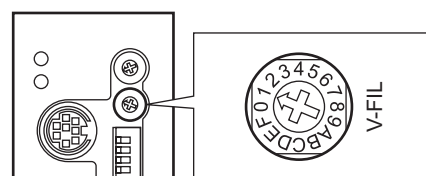

- Speed filter setting switch=0 (minimum)

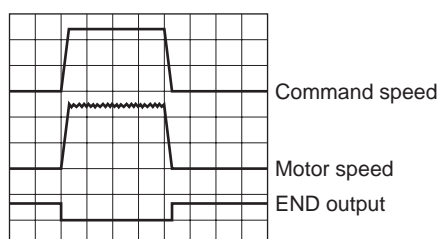

- Speed filter setting switch=F (maximum)

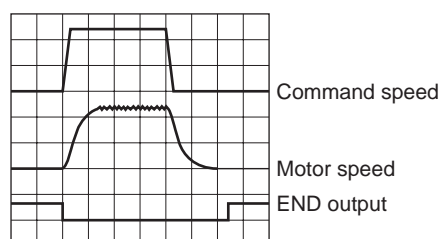

- To change the basic setting for speed filter: Refer to page 51.

12 Extended functions

This chapter explains the extended functions that can be set with the accessory data setter **OPX-2A** or the data editing software **MEXE02** (both are sold separately).

Using the **OPX-2A** or **MEXE02**, the driver parameters can be changed, and also test operation and monitoring operations can be performed. The key functions are listed below.

Parameter codes displayed on the **OPX-2A** screen are shown in brackets. Since these codes are also referenced in the main text herein, use these codes as keywords.

Parameters that can be set with the **OPX-2A** can also be set with **MEXE02**.

OPX-2A

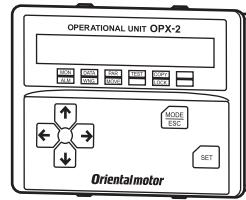

MEXE02

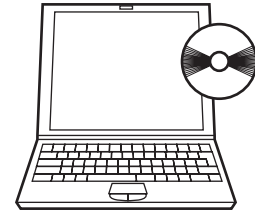

For the method to set parameters with the **OPX-2A** or **MEXE02**, refer to the operating manual for each product.

■ Application parameters

Item	Description	OPX-2A screen display	Ref.
Operating current	Set each operating current rate assigned to the current setting switch.	[APP-0-00] to [APP-0-15]	p.50
Speed filter	Set each filter time constant assigned to the speed filter setting switch.	[APP-1-00] to [APP-1-15]	p.51
Input signal mode	Select the input signal mode.	[APP-2-00]	-
Alarm code output	Change the setting to enable/disable of the alarm code output .	[APP-2-01]	p.54
C-ON input logic	Change the C-ON input logic.	[APP-2-02]	p.46
Positioning completion (END) signal range	Set the output condition for END signal.	[APP-2-03]	p.37
Positioning completion (END) signal offset	If the position at which the motor stops deviates from the theoretical position due to the effect of the load, friction, etc., set an offset for the output position corresponding to the END output.	[APP-2-04]	p.47
Current for push-motion operation	Set the operating current rate applicable to push-motion operation.	[APP-2-05] to [APP-2-12]	p.48
Standstill current	Set the standstill current as a percentage of the operating current.	[APP-3-00]	p.50
Speed error gain 1	Set the speed error gain. When this value is increased, motor vibration will decrease.	[APP-3-01]	p.51
Speed error gain 2	Set the speed error gain. When this value is increased, motor vibration at the time of speed change will decrease.	[APP-3-02]	
Position loop gain	Set the position loop gain. When this value is increased, motor response will become quicker and motor overshoot will decrease.	[APP-4-00]	p.51
Speed loop gain	Set the speed loop gain. When this value is increased, motor response will become quicker and motor overshoot will decrease.	[APP-4-01]	
Speed loop integral time constant	Set the integral time constant for speed loop. When this value is decreased, motor response will become quicker and motor overshoot will decrease.	[APP-4-02]	
Anti-vibration control	Change the setting to enable/disable of the anti-vibration control.	[APP-4-03]	p.51
Frequency of anti-vibration control	Set the frequency of anti-vibration control.	[APP-4-04]	
Operating speed of return to electrical home operation	Set the operating speed of return to electrical home operation.	[APP-6-00]	p.49
Acceleration and deceleration rate of return to electrical home operation	Set the acceleration and deceleration rate of return to electrical home operation.	[APP-6-01]	
Starting speed of return to electrical home operation	Set the starting speed of return to electrical home operation.	[APP-6-02]	
Operating speed of JOG operation	Set the operating speed of JOG operation.	[APP-7-00]	p.49

Item	Description	OPX-2A screen display	Ref.
Acceleration and deceleration rate of JOG operation	Set the acceleration and deceleration rate of JOG operation.	[APP-7-01]	p.49
Starting speed of JOG operation	Set the starting speed of JOG operation.	[APP-7-02]	

System parameters

Item	Description	OPX-2A screen display	Ref.
Electronic gear A1 to A4	Set the denominator of electric gear.	[SyS-0-00] to [SyS-0-03]	p.43
Electronic gear B	Set the numerator of electric gear.	[SyS-0-04]	
Pulse input mode	Select the pulse input mode.	[SyS-1-00]	p.44
Smooth drive	Change the setting to enable/disable of the smooth drive.	[SyS-1-01]	p.51
Excitation position at first current ON	Select the position at which the motor is excited after the power has been turned on.	[SyS-1-02]	p.46
Automatic return operation at current ON	When the motor was in a state of current ON, set whether or not to automatically return the motor to the position where it was stopped.	[SyS-1-03]	p.46
Motor rotation direction	Select rotation direction of the motor.	[SyS-1-04]	p.47

Note | When a system parameter has been changed, the new parameter will become effective after the power is cycled.

12.1 Setting

Resolution

The resolution can be set using the applicable driver switches or CS input.

Using the switches

Use the resolution switches (SW1-No.3/No.4) to set a desired resolution per revolution of the motor output shaft.

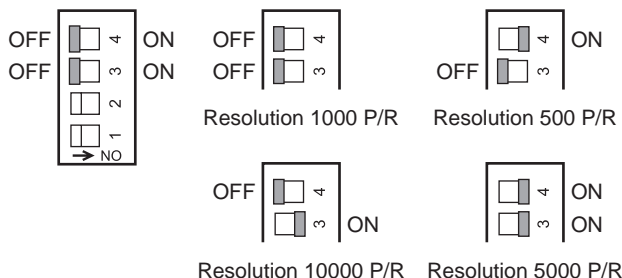

Note | The new settings of the resolution switches will become effective after the power is cycled.

The values of resolution switches (SW1-No.3/No.4) can be changed with the system parameters for electronic gear [SyS-0-00] to [SyS-0-04] as shown in the table below. Note that the calculated value must fall within the setting range specified below:

Resolution setting range: 100 to 10000 P/R

Factory setting: 1000 P/R

SW1-No.4 \ SW1-No.3	OFF	ON
	OFF	$1000 \times \frac{\text{Electronic gear B [SyS-0-04]}}{\text{Electronic gear A1 [SyS-0-00]}}$
ON	$1000 \times \frac{\text{Electronic gear B [SyS-0-04]}}{\text{Electronic gear A3 [SyS-0-02]}}$	$1000 \times \frac{\text{Electronic gear B [SyS-0-04]}}{\text{Electronic gear A4 [SyS-0-03]}}$

- Note**
- When a system parameter has been changed, the new parameter will become effective after the power is cycled.
 - If the calculated resolution exceeds the setting range, an electronic gear setting error warning will generate. Check all of four combinations in the above table. Refer to page 56.
 - If the power is cycled while an electronic gear setting error warning is present, an electronic gear setting error alarm will generate. Refer to page 53.

• Using the CS input

When the resolution switch (SW1-No.3) is set to OFF, the resolution setting can be changed according to the CS input.

Resolution switch	CS input OFF	CS input ON
SW1-No.3: OFF SW1-No.4: OFF	$1000 \times \frac{\text{Electronic gear B [SyS-0-04]}}{\text{Electronic gear A1 [SyS-0-00]}}$	$1000 \times \frac{\text{Electronic gear B [SyS-0-04]}}{\text{Electronic gear A2 [SyS-0-01]}}$
SW1-No.3: OFF SW1-No.4: ON	$1000 \times \frac{\text{Electronic gear B [SyS-0-04]}}{\text{Electronic gear A3 [SyS-0-02]}}$	$1000 \times \frac{\text{Electronic gear B [SyS-0-04]}}{\text{Electronic gear A4 [SyS-0-03]}}$

- Note**
- When the resolution switch (SW1-No.3) is set to ON, the CS input is disabled. The ON setting is maintained.
 - When the CS input is turned ON while the application parameter for abnormal operation data warning [APP-5-00] is set to “Enable,” a return to electrical home operation will be disabled and an abnormal operation data warning will generate. When performing a return to electrical home operation after the CS input is turned ON, turn the P-RESET input ON to confirm the electrical home position and then turn the RETURN input ON.

■ Pulse input mode

Set the desired pulse input mode of the driver according to the pulse output mode of the controller (pulse generator) used with the driver. The pulse input mode is set using the applicable driver switch or parameter.

- 1-pulse input mode
A pulse signal is input via the PLS input and the rotation direction is selected using the DIR input.
- 2-pulse input mode
When a pulse signal is input via the CW input, the motor will rotate in forward direction. If a pulse signal is input via the CCW input, the motor will rotate in reverse direction.
- Phase difference input mode (set by a parameter)
The motor will rotate in forward direction when the CCW input phase is delayed by 90° relative to the CW input.
The motor will rotate in reverse direction when the CCW input phase is advanced by 90° relative to the CW input.

• Using the switch

Set a desired mode using the pulse input mode select switch (SW1-No.1).

OFF: 2-pulse input mode, low active

ON: 1-pulse input mode, low active

Each mode can only be set with the low active using the pulse input mode select switch.

To select the high active, set the applicable parameter using the **OPX-2A** or **MEXE02**.

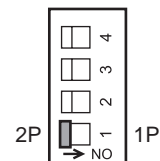

- Note**
- The new setting of the pulse input mode select switch will become effective after the power is cycled.
 - The factory setting of the pulse input mode depends on the destination country.

• Using the parameter

Set a desired mode using the system parameter for pulse input mode [SyS-1-00].

Pulse input mode	Input logic	Timing charts
1-pulse input mode	High active	
	Low active	
2-pulse input mode	High active	
	Low active	
Phase difference mode	x1	
	x2	
	x4	

Whether to cause the motor to rotate in CW direction or CCW direction when a forward direction pulse is input can be set using the system parameter for rotation direction [SyS-1-04]. Refer to page 47.

Note When a system parameter has been changed, the new parameter will become effective after the power is cycled.

• Pulse signal

Input a pulse with sharp rising and falling edges as shown in the figures. The figure shows the voltage levels of pulse signals.

• 1-pulse input mode, 2-pulse input mode

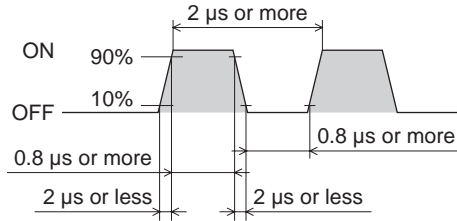

• Phase difference mode

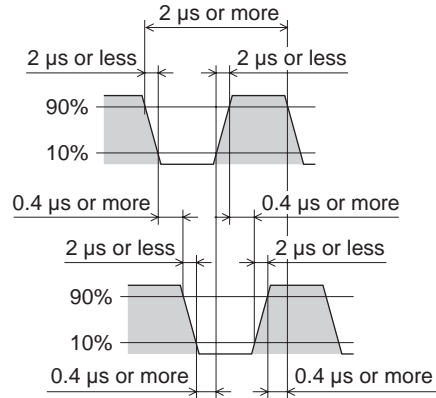

■ Motor excitation at power ON

When the power is turned on and the C-ON input switched ON, the motor will be excited at the current position. If the system parameter for excite position at first current on [SyS-1-02] is set to “Electrical angle 0°,” the motor will be excited at the position corresponding to electrical angle 0° (where the TIM output turns ON).

If the C-ON input is set to normally closed, however, the motor will be excited automatically at the electrical angle 0° position after the power has been turned on.

The C-ON input logic can be set using the application parameter for C-ON input logic [APP-2-02].

Note

- If the parameter for excite position at first current on [SyS-1-02] is set to “Electrical angle 0°,” the motor output shaft may move by a maximum of 3.6° when the C-ON input is turned ON.
- When a system parameter has been changed, the new parameter will become effective after the power is cycled.

■ Automatic return operation

This is a return operation when the motor is in a state of current ON.

If the system parameter for auto return [SyS-1-03] is set to “Enable,” the motor can automatically return, when the C-ON input is turned ON or FREE input is turned OFF, to the position where it was stopped.

Note

- When a system parameter has been changed, the new parameter will become effective after the power is cycled.

■ Setting the motor rotation direction

Set a desired motor rotation direction using the system parameter for rotation direction [SyS-1-04].

- Note**
- When a system parameter has been changed, the new parameter will become effective after the power is cycled.
 - The CW and CCW indicate the rotation direction of the motor, as seen from the output shaft. The output shaft of the **TH** geared typed motors with ratios of 20 and 30, as well as all ratios of the Harmonic geared type motors, rotate in the opposite direction of the motor shaft.

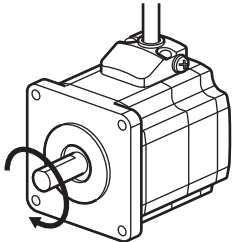
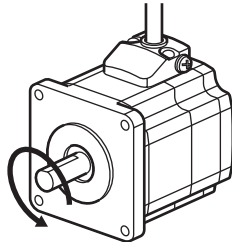
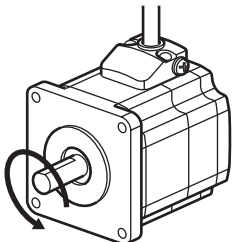
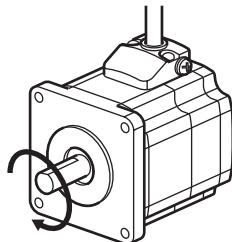
Setting of rotation direction parameter [SyS-1-04]	CW pulse is input	CCW pulse is input
When "+=CW" is set	<ul style="list-style-type: none"> • The command position increases. • The motor rotates in CW direction. 	<ul style="list-style-type: none"> • The command position decreases. • The motor rotates in CCW direction. 
When "+=CCW" is set	<ul style="list-style-type: none"> • The command position increases. • The motor rotates in CCW direction. 	<ul style="list-style-type: none"> • The command position decreases. • The motor rotates in CW direction. 

■ Setting the positioning completion (END) signal offset

The motor stops at the theoretical stopping position as a center point or thereabout.

If the motor stops at a position deviated from the theoretical stopping position due to the load, friction, etc., and the deviation band exceeds the specified END signal range, the END output will not turn ON.

In this case, use the application parameter for END signal offset [APP-2-04] to compensate the deviation band.

12.2 Operation

■ Push-motion operation

Push-motion operation is a type of operation where pulses are input to pressurize the load continuously.

When selecting a push-motion operation with the application parameter for I/O input mode [APP-2-00], turning the T-MODE input ON and inputting pulses, push-motion operation will start.

Pulses will be continuously input and accumulate even when the load is balanced with the torque.

Note

- Do not perform push-motion operation with geared types. Doing so may cause damage to the motor or gearhead.
- If push-motion operation is performed for a long time while a large push-motion current is set, the driver may increase the temperature rise and generate the overheat protection alarm.

• Setting the current for push-motion operation

Set a desired current for push-motion operation using any of the application parameters for push-motion current 0 to 7 (any one of [APP-2-05] to [APP-2-12]). The current value set in the parameter will be used to limit the output torque.

Select a desired current based on a combination of ON/OFF status of the M0 to M2 inputs.

Setting range: 0 to 100%

Push-motion current parameter	Initial value (%)	M2	M1	M0
0 [APP-2-05]	30.0	OFF	OFF	OFF
1 [APP-2-06]	40.0	OFF	OFF	ON
2 [APP-2-07]	50.0	OFF	ON	OFF
3 [APP-2-08]	60.0	OFF	ON	ON
4 [APP-2-09]	70.0	ON	OFF	OFF
5 [APP-2-10]	80.0	ON	OFF	ON
6 [APP-2-11]	90.0	ON	ON	OFF
7 [APP-2-12]	100.0	ON	ON	ON

• Performing the push-motion operation

1. Set the application parameter for I/O input mode [APP-2-00] to "Push-motion operation."
2. Select a current value using the M0 to M2 inputs.
3. Turn the T-MODE input ON.
4. Input CW or CCW pulses.
The load is pressurized continuously while the T-MODE input is ON.
The output torque is limited at the current value selected for the parameter in step 2.
When the output torque reaches the current value selected for the parameter in step 2, the TLC output will turn ON. Refer to page 64 and page 65 for the timing charts.
5. Stop the pulse input.
6. Turn the T-MODE input OFF.

Note

- During push-motion operation, the automatic current cutback function does not operate even when the pulse input is stopped. In other words, the value of push current selected for the parameter is maintained.
- If the load is removed during push-motion operation, the motor will move at high speed the number accumulated pulses.
- Since pulses are input continuously during push-motion operation, a prolonged push condition may generate an excessive position deviation alarm. If the push condition continues for a prolonged period, stop the pulse input. Whether or not the motor is pushing the load can be determined using the TLC output.

■ Test operation

Test operation is performed using the data setter **OPX-2A** or the data editing software **MEXE02**.

Perform test operation (JOG operation) to check the levels of vibration and noise or to check how operate in a push-motion operation and/or a return to electrical home operation.

Set the required conditions for JOG operation using the following parameters:

- Operating speed of JOG operation [APP-7-00]
- Acceleration and deceleration rate of JOG operation [APP-7-01]
- Starting speed of JOG operation [APP-7-02]

Note | JOG operation is performed only while each applicable operation button is pressed on the **OPX-2A** or clicked in **MEXE02**. External signals cannot be used to start/stop the motor.

■ Return to electrical home operation

When the RETURN input is turned ON, the motor will start a return to electrical home operation.

The electrical home (position) refers to the motor position effective when the driver power is turned on, or the position when the P-RESET input is turned ON.

Set the required conditions for return to electrical home operation using the following parameters:

- Operating speed of return operation [APP-6-00]
- Acceleration and deceleration rate of return operation [APP-6-01]
- Starting speed of return operation [APP-6-02]

Refer to page 68 for the timing chart.

- Note** |
- Pulses are not counted during return to electrical home operation.
 - When the CS input is turned ON while the application parameter for abnormal operation data warning [APP-5-00] is set to "Enable," a return to electrical home operation will be disabled and an abnormal operation data warning will generate. When a return to electrical home operation is to be performed after the CS input is turned ON, turn the P-RESET input ON to confirm the electrical home position and then turn the RETURN input ON.
 - Turning the P-RESET input ON while a return to electrical home operation is still in progress will set the applicable position as the electrical home, and the motor will stop.

12.3 Adjustment

The operating current, motor operation at start/stop, and response in reaction to the command can be adjusted. The items that can be adjusted vary between the normal mode and the current control mode.

Item	Description	Normal mode	Current control mode
Operating current	Adjust the current during operation.	Can be adjusted	Can be adjusted
Standstill current	Adjust the current at standstill.		Can not be adjusted
Speed filter	Apply a filter to input pulses to make the pulses smooth.		Can be adjusted
Smooth drive	Insert interpolation pulses between input pulses.		Can be adjusted
Speed error gain	Suppress vibration while the motor is accelerating/decelerating operating.		Can not be adjusted
Position loop gain	Vibration that generates while the motor is accelerating/decelerating or at standstill can be adjusted to an optimal level.	Can not be adjusted	Can be adjusted
Speed loop gain			
Speed integral time constant			
Anti-vibration control	Enclosure vibration that occurs with an equipment of low rigidity can be adjusted to an optimal level.		

Control mode

The driver operates in one of two control modes: the normal mode, and the current control mode. The desired mode can be set using the control mode select switch (SW1-No.2). If noise is heard during high-speed operation or there is notable vibration, it may be effective to switch to the current control mode.

Note, however, that a slight delay may occur in the current control mode, compared to the normal mode, depending on the condition of the load.

Keep the driver in the normal mode during normal conditions of use.

OFF: Normal mode (NORM)

ON: Current control mode (CCM)

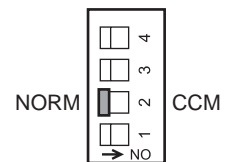

- Note** • The new setting of the control mode select switch will become effective after the power is cycled.
- In the normal mode, the CCM input becomes effective.

Operating current

Set a desired operating current using the current setting switch (CURRENT). The operating current to be set is the maximum output current multiplied by the operating current rate (%) set to each dial setting of the current setting switch, where “F” corresponds to 100%. One of 16 operating current levels from 0 to F can be set. If the load is small and there is an ample allowance for torque, the motor temperature rise can be suppressed by setting a lower operating current.

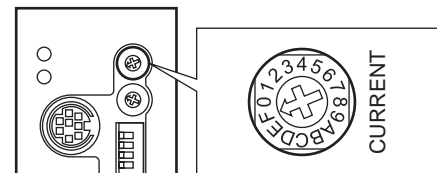

The value assigned to each dial setting of the current setting switch can be changed by using a corresponding application parameter for operating current at CURRENT (one of [APP-0-00] to [APP-0-15]).

- Note** Excessively low operating current may cause a problem in starting the motor or holding the load in position. Do not lower the operating current more than necessary.

Standstill current

When the motor stops, the current cutback function will be actuated to lower the motor current to the standstill current.

The standstill current is a value that the operating current which was set with the current setting switch is multiplied by a ratio of the standstill current.

Set a desired standstill current using the application parameter for standstill current [APP-3-00].

The initial value is 50%.

■ Speed filter

The motor response to input pulses can be adjusted using the speed filter setting switch (V-FIL). One of 16 speed filter levels from 0 to F can be set. When the speed filter level is raised, vibration can be suppressed during low-speed operation, and starting/stopping of the motor will become smooth.

Note, however, that an excessively high filter level will result in lower synchronicity with commands.

Set an appropriate value according to the specific load and purpose. The value assigned to each dial setting of the speed filter setting switch can be changed by using a corresponding application parameter for speed filter at V-FIL (one of [APP-1-00] to [APP-1-15]).

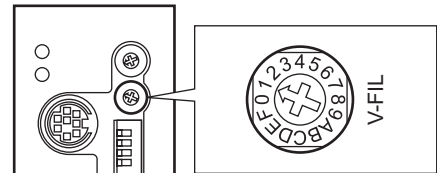

■ Smooth drive

When the smooth drive function is used, the driver automatically implements microstep control over input pulses. This helps suppress motor vibration.

If the smooth drive function is not used, vibration may increase in the low-speed range although starting characteristics will improve.

Set whether or not to use the smooth drive using the system parameter for smooth drive [SyS-1-01].

Note When a system parameter has been changed, the new parameter will become effective after the power is cycled.

■ Speed error gain

The speed error gain is used to suppress vibration while the motor is operating or accelerating/ decelerating.

Set the required conditions using the following application parameters:

- Speed error gain 1 [APP-3-01]This adjusts vibration during operation.
- Speed error gain 2 [APP-3-02]This adjusts vibration during acceleration/deceleration.

Note Since the initial values reflect results of adjustment, do not change the initial values in normal conditions of use.

■ Position loop gain, speed loop gain, speed loop integral time constant

These items are effective in the current control mode.

Vibration that occurs while the motor is accelerating/decelerating or at standstill can be adjusted to an optimal value. (The optimal value varies depending on the equipment and operating conditions.)

Set the required conditions using the following application parameters:

- Position loop gain [APP-4-00].....This adjusts the motor response in reaction to the position deviation. When this value is increased, the motor response will become quicker and motor overshoot will decrease. An excessively high value may cause hunting.
- Speed loop gain [APP-4-01]This adjusts the motor response in reaction to the speed deviation. When this value is increased, motor response will become quicker and motor overshoot will decrease. An excessively high value may cause hunting.
- Speed loop integral time constant [APP-4-02]This decreases the deviation that cannot be adjusted with the speed loop gain. When this value is decreased, motor response will become quicker and motor overshoot will decrease. An excessively low value may cause hunting.

■ Anti-vibration control

This item is effective in the current control mode.

Even when the motor is installed into a machine of low rigidity, residual vibration can be suppressed during positioning, in order to shorten the positioning time. (The optimal value varies depending on the equipment and operating conditions.)

Set the required conditions using the following application parameters:

- Anti-vibration control [APP-4-03].....Set whether or not to enable anti-vibration control.
- Frequency of anti-vibration control [APP-4-04].....Set the frequency of anti-vibration control.

13 Inspection

It is recommended that periodic inspections be conducted for the items listed below after each operation of the motor. If an abnormal condition is noted, discontinue any use and contact your nearest Oriental Motor sales office.

■ During inspection

- Are any of the motor mounting screws loose?
- Check for any unusual noises in the motor bearings (ball bearings) or other moving parts.
- Are there any scratches, signs of stress or loose driver connections in the motor lead wires?
- Are the motor output shaft and load shaft out of alignment?
- Check for a blocked opening of the driver case.
- Are any of the driver mounting screws or power connection terminal screws loose?
- Are there any strange smells or appearances within the driver?

Note | The driver uses semiconductor elements. Handle the driver with care since static electricity may damage semiconductor elements.

14 Alarms and warnings

The driver provides alarms that are designed to protect the driver from overheating, poor connection, error in operation, etc. (protective functions), as well as warnings that are output before the corresponding alarms generate (warning functions).

14.1 Alarms

When an alarm generates, the ALM output will turn OFF and the motor will stop. (The motor will continue to operate after generating the abnormal operation data alarm, because abnormal operation data alarm does not cut off the motor current.)

When the application parameter for AL0-2 signal output [APP-2-01] is set to “Enable”, the READY output, TLC output and TIM2 output will automatically switch to the AL0 output, AL1 output and AL2 output, respectively.

When an alarm generates, the ALARM LED will blink. The cause of the alarm can be checked by counting the number of times the ALARM LED blinks.

Present alarms can be checked using the data setter **OPX-2A** or the data editing software **MEXE02**.

The alarm records of up to ten most recent alarms starting from the latest one can be checked and cleared.

Example: Overvoltage alarm (number of blinks: 3)

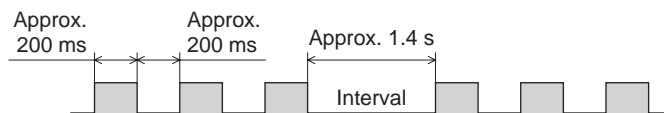

■ Alarm reset

Perform one of the reset operations specified below.

Before resetting an alarm, always remove the cause of the alarm and ensure safety.

Refer to page 65 for the timing chart.

- Turn the ALM-RST input to ON and then OFF. (The alarm will be reset at the OFF edge of the input.)
- Perform an alarm reset using the **OPX-2A** or **MEXE02**.
- Cycle the power.

Note Some alarms cannot be reset with the ALM-RST input, **OPX-2A** or **MEXE02**. Check the following table to identify which alarms meet this condition. To reset these alarms, cycle the power.

■ Descriptions of alarms

See page 76 for more information about the alarm parameters.

Alarm type	No. of ALARM LED blinks	Alarm code output			Alarm code	Motor operation upon alarm *	Reset using the ALM-RST input/ OPX-2A/MEXE02
		AL2	AL1	AL0			
Overheat protection	2	OFF	ON	OFF	21	x	Can reset
Overload					30		
Overspeed					31		
Command pulse error					34		
Overvoltage protection	3	OFF	ON	ON	22	x	Cannot reset
Undervoltage					25		
Excessive position deviation during current ON	4	ON	OFF	OFF	10	x	Can reset
Excessive position deviation during current OFF					12		
Abnormal operation data	7	ON	ON	ON	70	○	
Electronic gear setting error					71		
Sensor error during operation	8	OFF	OFF	OFF	28	x	Cannot reset
Initial sensor error					42		
Initial rotor rotation error					43		
Motor combination error					45		
EEPROM error	9	OFF	OFF	ON	41		

* The symbols in the "Motor operation upon alarm" field are explained below.

×: When an alarm generates, the motor current will be cut off and the motor will lose its holding torque.

○: Even when an alarm generates, the motor current will not be cut off and the motor position will be held.

Cause	Remedial action
The internal temperature of the driver exceeded 85 °C (185 °F).	Review the ventilation condition in the enclosure.
The cumulative value of applied loads exceeding the maximum torque reached or exceeded the value set in the parameter for overload [APP-5-03].	<ul style="list-style-type: none"> • Reduce the load or increase the acceleration/deceleration rate. • If the driver is in the current control mode, increase the current limit value. • Check if the electromagnetic brake is released during operation.
The speed of the motor output shaft exceeded 4500 r/min (excluding geared motors).	<ul style="list-style-type: none"> • Check the electronic gear setting and reduce the speed of the motor output shaft to 4500 r/min or less. • If the motor is overshooting at the time of acceleration, increase the acceleration/deceleration rate.
The command pulse frequency exceeded the specified value.	<ul style="list-style-type: none"> • Set the command pulse frequency to 500 kHz or less. • Check the electronic gear setting and reduce the speed of the motor output shaft to 4500 r/min or less.
<ul style="list-style-type: none"> • A voltage exceeding the specified value was applied. • A large inertial load was operated. 	<ul style="list-style-type: none"> • Check the input voltage of the main power supply. • If this alarm generates during operation, decrease the inertia load (inertial load 10 times less than the rotor inertia) or increase the acceleration/deceleration rate.
The main power was cut off momentarily or the voltage became low.	Check the input voltage of the main power supply.
<ul style="list-style-type: none"> • When the motor was in a state of current ON, the deviation between the command position and actual position exceeded the value set in the parameter for overflow rotation during current on [APP-5-01]. • The load is large or acceleration/deceleration rate is too short. 	<ul style="list-style-type: none"> • Reduce the load or increase the acceleration/deceleration rate. • If the driver is in the current control mode, increase the current limit value.
The C-ON input was turned ON while an excessive position deviation warning during current OFF was present.	<ul style="list-style-type: none"> • Do not turn the C-ON input ON while an excessive position deviation warning at current OFF is present. • Set the parameter for auto return [SyS-1-03] to "Disable."
Return to electrical home operation was performed while an abnormal operation data warning was present.	Do not perform return to electrical home operation while an abnormal operation data warning is present.
The power was turned on when the resolution set by the electronic gear was outside the specified range.	Turn on the power again after setting the "electronic gear" parameter correctly so that the resolution is in a range of "100 to 10000 P/R."
A sensor error occurred while the motor was operating.	Turn off the power and check the connection of the motor cable and driver, and then cycle the power.
A sensor error occurred when the power was turned on.	Turn off the power and check the connection of the motor cable and driver, and then cycle the power.
The motor output shaft rotated at a speed of 15 r/min or more while the initialization was still in progress following a power on.	Adjust the load and make sure the motor output shaft does not turn due to an external force when the power is turned on.
A motor not supported by the driver is connected.	Check the model name of motor and driver, and use the motor and driver in the correct combination.
The stored data was damaged.	Initialize the all parameters using the OPX-2A or MEXE02 .

14.2 Warnings

When a warning generates, the WNG output will turn ON. The motor will continue to operate.

Once the cause of the warning is removed, the WNG output will turn OFF automatically.

Present warnings can be checked using the data setter **OPX-2A** or the data editing software **MEXE02**.

The warning records of up to ten most recent warnings starting from the latest one can be checked and cleared.

Note The warning records will also be cleared automatically by powering off the driver.

■ Descriptions of warnings

See page 78 for more information about the warning parameters.

Warning type	Warning code	Cause	Remedial action
Excessive position deviation warning during current ON	10	<ul style="list-style-type: none"> When the motor was in a state of current ON, the deviation between the command position and actual position exceeded the value set in the parameter for overflow warning rotation during current on [APP-5-04]. The load is large or acceleration/ deceleration rate is too short. 	<ul style="list-style-type: none"> Reduce the load or increase the acceleration/deceleration rate If a torque limit is set using an extended function, increase the setting value.
Excessive position deviation warning during current OFF	12	When the motor was in a state of current OFF, the deviation between the command position and actual position exceeded the value set in the parameter for overflow rotation during current off [APP-5-02]. (This warning is output when the parameter for auto return [SyS-1-03] is set to "Enable".)	<ul style="list-style-type: none"> Reduce the amount of rotation at current OFF to the specified setting value or less. Or, change the setting value. Turn the CLR input ON to clear the position deviation.
Overheat	21	The temperature inside the driver exceeded the value set in the parameter for overheat warning [APP-5-07].	Review the ventilation condition in the enclosure.
Overvoltage	22	<ul style="list-style-type: none"> The voltage of the main power supply exceeded the value set in the parameter for overvoltage warning [APP-5-05]. A large inertial load was operated. 	<ul style="list-style-type: none"> Check the input voltage of the main power supply. If this alarm generates during operation, decrease the inertia load (inertial load 10 times less than the rotor inertia) or increase the acceleration/deceleration rate.
Undervoltage	25	<ul style="list-style-type: none"> The main power supply voltage dropped from the value set in the parameter for undervoltage warning [APP-5-06]. The main power was cut off momentarily or the voltage became low. 	Check the input voltage of the main power supply.
Overload	30	<ul style="list-style-type: none"> A load exceeding the maximum torque was applied for the time set in parameter for the overload warning [APP-5-08] or longer. The load is large or acceleration/ deceleration rate is too short. 	<ul style="list-style-type: none"> Reduce the load or increase the acceleration/deceleration rate If the driver is in the current control mode, increase the current limit value. Check if the electromagnetic brake is released during operation.
Overspeed	31	The detected motor speed exceeded the value set in the parameter for overspeed warning [APP-5-09].	<ul style="list-style-type: none"> Check the electronic gear setting and reduce the speed of the motor output shaft to the value set in the parameter or less. If the motor is overshooting at the time of acceleration, increase the acceleration/ deceleration rate.
Abnormal operation data	70	The CS input was changed when the motor was in a state of current ON.	Do not change the CS input when the current is ON.
		The traveled distance from the electrical home exceeded the control range (2,147,483,648 pulses). [This alarm generates when the application parameter for abnormal operation data warning [APP-5-00] is set to "Enable".]	Turn the P-RESET input ON and set the electrical home, again.
Electronic gear setting error	71	The resolution set by the electronic gear is outside the specified range.	Set the "electronic gear" parameter correctly so that the resolution is in a range of "100 to 10000 P/R."

15 Troubleshooting and remedial actions

During motor operation, the motor or driver may fail to function properly due to an improper speed setting or wiring. When the motor cannot be operated correctly, refer to the contents provided in this section and take appropriate action. If the problem persists, contact your nearest Oriental Motor sales office.

Phenomenon	Possible cause	Remedial action
<ul style="list-style-type: none"> The motor is not excited. The motor output shaft can be moved by hand. 	The C-ON input is turned OFF.	<ul style="list-style-type: none"> Turn the C-ON input ON and confirm that the motor will be excited. Check the setting of the application parameter for C-ON input logic [APP-2-02].
	The FREE input is turned ON.	Turn the FREE input OFF.
The motor does not operate.	The CLR input is turned ON.	Turn the CLR input OFF.
	The CW input or CCW input is not connected properly.	<ul style="list-style-type: none"> Check the connection between the controller and driver. Check the pulse signal specifications (voltage, width).
	The CW input and CCW input are turned ON simultaneously in the 2-pulse input mode.	Each pulse signal input should specify either the CW input or CCW input, but not both. Make sure the terminal not receiving the signal input remains OFF.
	The pulse signal is connected to DIR input in the 1-pulse input mode.	Connect the pulse signal to the PLS input.
	An electromagnetic brake motor is used and the electromagnetic brake is in the holding state.	Supply power to the electromagnetic brake to release it.
The motor rotates in the direction opposite to the specified direction.	The CW input and CCW input are connected in reverse in the 2-pulse input mode.	Connect CW pulse signals via the CW input, and connect CCW pulse signals via the CCW input.
	The DIR input is set in reverse in the 1-pulse input mode.	Turn the DIR input ON to rotate the motor in CW direction, and turn the input OFF to rotate the motor in CCW direction.
	The system parameter for rotation direction [SyS-1-04] is set wrong.	Check the setting of the parameter for rotation direction [SyS-1-04].
The gear output shaft rotates in the direction opposite to the motor.	A gear that rotates in the direction opposite to the motor shaft is used.	<ul style="list-style-type: none"> With TH geared motors, the gear output shaft rotates in the direction opposite to the motor when the gear ratio is 20 or 30. With Harmonic geared motors, the gear output shaft always rotates in the direction opposite to the motor.
Motor operation is unstable.	Pulse signals are not connected properly.	<ul style="list-style-type: none"> Check the connection between the controller and driver. Check the pulse signal specifications (voltage, width).
Motor vibration is too great.	Load is too small.	Lower the current using the current setting switch. If the motor output torque is too large relative to the load, vibration will increase.
The TIM output does not turn ON.	The CS input was turned OFF while the motor was operating.	The TIM output may not turn ON if the CS input is switched from ON to OFF.

Note | I/O signals can be monitored using the **OPX-2A** or **MEXE02**. Use to check the wiring condition of the I/O signals.

16 General specifications

		Motor	Driver
Degree of protection		IP65 (Flexible extension cable set) IP20 (Double shaft type, models including "S" in the motor name)	IP20
Operation environment	Ambient temperature	-10 to +50 °C (+14 to +122 °F) *1 (non-freezing) Harmonic geared type: 0 to +40 °C (+32 to +104 °F) *1 (non-freezing)	0 to +50 °C (+32 to +122 °F) (non-freezing)
	Humidity	85% or less (non-condensing)	
	Altitude	Up to 1000 m (3300 ft.) above sea level	
	Surrounding atmosphere	No corrosive gas, dust, water or oil	
Storage environment	Ambient temperature	-20 to +60 °C (-4 to +140 °F) (non-freezing)	
	Humidity	85% or less (non-condensing)	
	Altitude	Up to 3000 m (10000 ft.) above sea level	
	Surrounding atmosphere	No corrosive gas, dust, water or oil	
Shipping environment	Ambient temperature	-20 to +60 °C (-4 to +140 °F) (non-freezing)	
	Humidity	85% or less (non-condensing)	
	Altitude	Up to 3000 m (10000 ft.) above sea level	
	Surrounding atmosphere	No corrosive gas, dust, water or oil	
Insulation resistance		100 MΩ or more when 500 VDC megger is applied between the following places: Case - Motor and sensor windings Case - Electromagnetic brake windings	-
Dielectric strength		Sufficient to withstand 1.0 kVAC at 50/60 Hz applied between the following places for 1 minute:*2 Case - Motor and sensor windings Case - Electromagnetic brake windings	-

*1 When installing a motor to a heat sink of a capacity at least equivalent to an aluminum plate [100×100 mm (3.94×3.94 in.), thickness 6 mm (0.24 in.)].

*2 0.5 kVAC for the ARM24 and ARM26 types

17 Accessories (sold separately)

■ Motor cable

The cable supplied with the **AR** Series is all you need to connect the motor and driver.

Take note, however, that if you wish to connect the motor and driver over a distance of 3 m (9.8 ft.), the supplied cable is not long enough and you must use a connection cable or extension cable.

When installing the motor on a moving part, use a flexible cable offering excellent flexibility.

● System configuration

Extending the wiring length using a connection cable

In this case, the supplied cable will not be used.

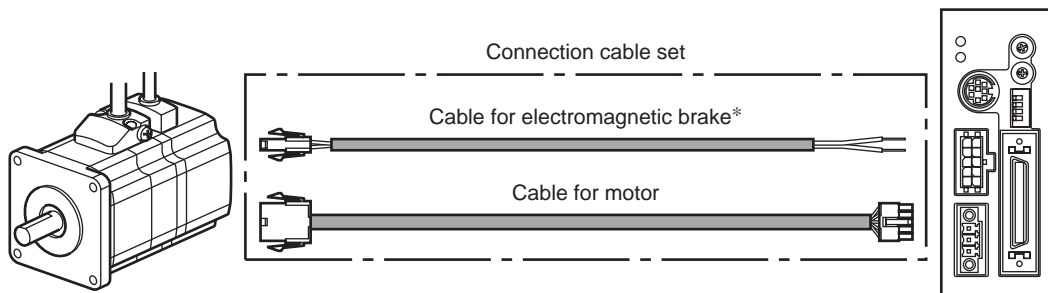

* Only when the motor is of electromagnetic brake type.

Extending the wiring length using an extension cable

Use a supplied cable. And connect an extension cable to the supplied cable.

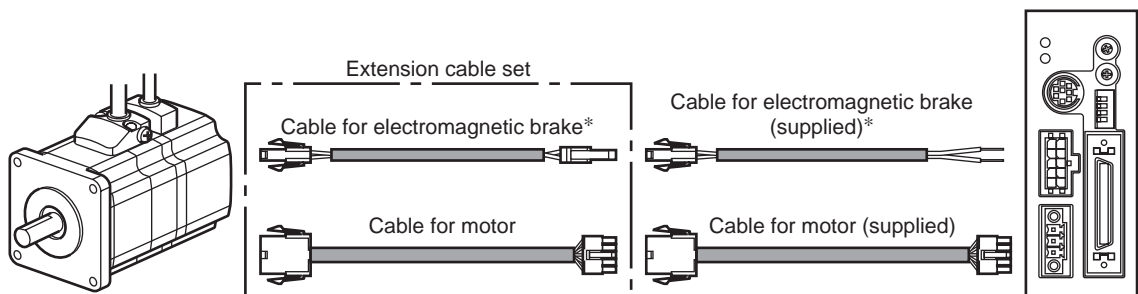

* Only when the motor is of electromagnetic brake type.

Note When extending the wiring length by connecting an extension cable to the supplied cable, keep the total cable length to 30 m (98.4 ft.) or less.

• Connection cable

A cable is needed to connect the motor and driver. Use a flexible connection cable in application where the cable is bent and flexed repeatedly.

The cable set for electromagnetic brake motors consists of two cables, one for motor and the other for electromagnetic brake.

• Connection cable set
For standard motor

Model (IP65 type)	Model (IP20 type)	Length [m (ft.)]
CC010VAF2	CC010VA2F2	1 (3.3)
CC020VAF2	CC020VA2F2	2 (6.6)
CC030VAF2	CC030VA2F2	3 (9.8)
CC050VAF2	CC050VA2F2	5 (16.4)
CC070VAF2	CC070VA2F2	7 (23)
CC100VAF2	CC100VA2F2	10 (32.8)
CC150VAF2	CC150VA2F2	15 (49.2)
CC200VAF2	CC200VA2F2	20 (65.6)
CC300VAF2	CC300VA2F2	30 (98.4)

• Flexible connection cable set
For standard motor

Model (IP65 type)	Model (IP20 type)	Length [m (ft.)]
CC010VAR2	CC010VA2R2	1 (3.3)
CC020VAR2	CC020VA2R2	2 (6.6)
CC030VAR2	CC030VA2R2	3 (9.8)
CC050VAR2	CC050VA2R2	5 (16.4)
CC070VAR2	CC070VA2R2	7 (23)
CC100VAR2	CC100VA2R2	10 (32.8)
CC150VAR2	CC150VA2R2	15 (49.2)
CC200VAR2	CC200VA2R2	20 (65.6)
CC300VAR2	CC300VA2R2	30 (98.4)

• Connection cable set
For electromagnetic brake motor

Model (IP65 type)	Model (IP20 type)	Length [m (ft.)]
CC010VAFB2	CC010VA2FB2	1 (3.3)
CC020VAFB2	CC020VA2FB2	2 (6.6)
CC030VAFB2	CC030VA2FB2	3 (9.8)
CC050VAFB2	CC050VA2FB2	5 (16.4)
CC070VAFB2	CC070VA2FB2	7 (23)
CC100VAFB2	CC100VA2FB2	10 (32.8)
CC150VAFB2	CC150VA2FB2	15 (49.2)
CC200VAFB2	CC200VA2FB2	20 (65.6)
CC300VAFB2	CC300VA2FB2	30 (98.4)

• Flexible connection cable set
For electromagnetic brake motor

Model (IP65 type)	Model (IP20 type)	Length [m (ft.)]
CC010VARB2	CC010VA2RB2	1 (3.3)
CC020VARB2	CC020VA2RB2	2 (6.6)
CC030VARB2	CC030VA2RB2	3 (9.8)
CC050VARB2	CC050VA2RB2	5 (16.4)
CC070VARB2	CC070VA2RB2	7 (23)
CC100VARB2	CC100VA2RB2	10 (32.8)
CC150VARB2	CC150VA2RB2	15 (49.2)
CC200VARB2	CC200VA2RB2	20 (65.6)
CC300VARB2	CC300VA2RB2	30 (98.4)

Connector pin assignments of "cable for motor"

Pin No.	Color	Lead size
1	White	AWG26 (0.14 mm ²)
2	Black	
3	Purple	
4	Brown	
5 *	Green	AWG22 (0.3 mm ²)
6	Red	
7	Gray	
8	Blue	
9	Orange	AWG26 (0.14 mm ²)
10	Drain wire	

* No wiring for **AR24** and **AR26**

• Motor side

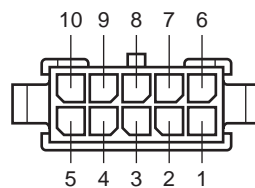

Model: 43020-1000 (Molex)

• Driver side

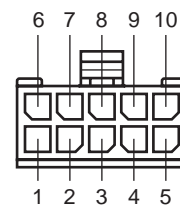

Model: 43025-1000 (Molex)

Connector pin assignments of "cable for electromagnetic brake"

Pin No.	Color	Lead size
1	White	AWG20 (0.5 mm ²) *
2	Black	

* AWG21 (0.5 mm²) for flexible cable

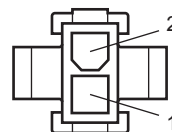

Model: 5559-02P-210 (Molex)

43020-0200 (Molex) for the cable of IP20 types

- Extension cable

This cable is needed to extend the wiring length between the motor and driver. Use a flexible extension cable in application where the cable is bent and flexed repeatedly.

The cable set for electromagnetic brake motors consists of two cables, one for motor and the other for electromagnetic brake.

- Extension cable set
For standard motor

Model (IP65 type)	Model (IP20 type)	Length [m (ft.)]
CC010VAFT2	CC010VA2F2	1 (3.3)
CC020VAFT2	CC020VA2F2	2 (6.6)
CC030VAFT2	CC030VA2F2	3 (9.8)
CC050VAFT2	CC050VA2F2	5 (16.4)
CC070VAFT2	CC070VA2F2	7 (23)
CC100VAFT2	CC100VA2F2	10 (32.8)
CC150VAFT2	CC150VA2F2	15 (49.2)
CC200VAFT2	CC200VA2F2	20 (65.6)

- Flexible extension cable set
For standard motor

Model (IP65 type)	Model (IP20 type)	Length [m (ft.)]
CC010VART2	CC010VA2R2	1 (3.3)
CC020VART2	CC020VA2R2	2 (6.6)
CC030VART2	CC030VA2R2	3 (9.8)
CC050VART2	CC050VA2R2	5 (16.4)
CC070VART2	CC070VA2R2	7 (23)
CC100VART2	CC100VA2R2	10 (32.8)
CC150VART2	CC150VA2R2	15 (49.2)
CC200VART2	CC200VA2R2	20 (65.6)

- Extension cable set
For electromagnetic brake motor

Model (IP65 type)	Model (IP20 type)	Length [m (ft.)]
CC010VAFBT2	CC010VA2FBT2	1 (3.3)
CC020VAFBT2	CC020VA2FBT2	2 (6.6)
CC030VAFBT2	CC030VA2FBT2	3 (9.8)
CC050VAFBT2	CC050VA2FBT2	5 (16.4)
CC070VAFBT2	CC070VA2FBT2	7 (23)
CC100VAFBT2	CC100VA2FBT2	10 (32.8)
CC150VAFBT2	CC150VA2FBT2	15 (49.2)
CC200VAFBT2	CC200VA2FBT2	20 (65.6)

- Flexible extension cable set
For electromagnetic brake motor

Model (IP65 type)	Model (IP20 type)	Length [m (ft.)]
CC010VARBT2	CC010VA2RBT2	1 (3.3)
CC020VARBT2	CC020VA2RBT2	2 (6.6)
CC030VARBT2	CC030VA2RBT2	3 (9.8)
CC050VARBT2	CC050VA2RBT2	5 (16.4)
CC070VARBT2	CC070VA2RBT2	7 (23)
CC100VARBT2	CC100VA2RBT2	10 (32.8)
CC150VARBT2	CC150VA2RBT2	15 (49.2)
CC200VARBT2	CC200VA2RBT2	20 (65.6)

Connector pin assignments of extension cable

The pin assignment is same with "Connection cable" on page.60

■ Data setter

The data setter lets you set parameters for your **AR** Series with ease and also functions as a monitor.

Model: **OPX-2A**

■ Data editing software

The data editing software lets you set parameters for your **AR** Series and monitor its operating condition using a PC. The software comes with a PC interface cable [5 m (16.4 ft.)]. The cable is connected to the USB port on the PC.

Model: **MEXE02**

■ Driver cable

A shielded cable for driver I/O signals (36 pins) offering excellent noise resistance. The ground wires useful to grounding are provided at both ends of the cable.

Model	Connector type	Length [m (ft.)]
CC36D1E	Straight	1 (3.3)
CC36D2E		2 (6.6)

■ Connector-terminal block conversion unit

The driver and programmable controller can be connected via a terminal block.

A shielded cable is used. The ground wires useful to grounding are provided at both ends of the cable.

Model	Type	Length [m (ft.)]
CC36T10E	Single-row	1 (3.3)

18 Reference

18.1 Timing charts

■ Power input

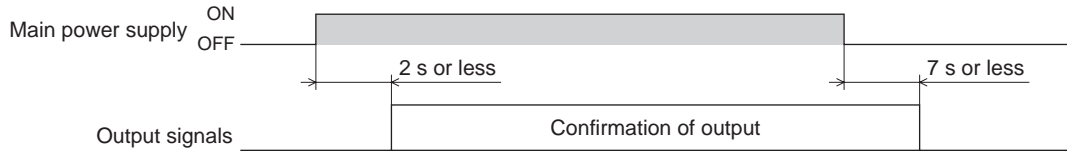

■ C-ON input

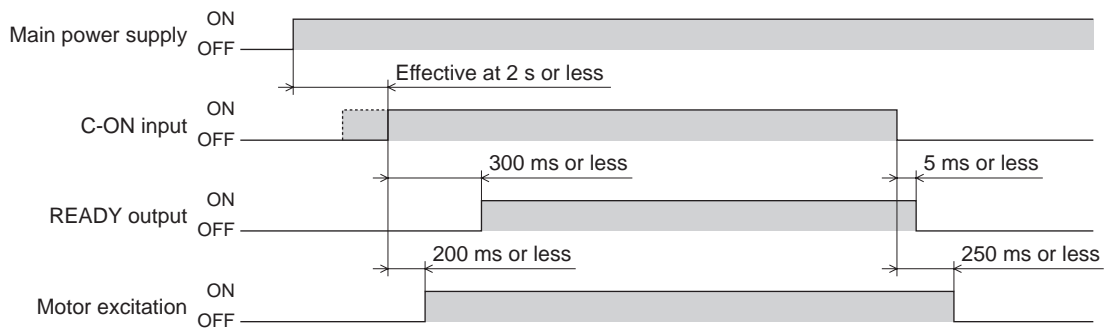

■ FREE input

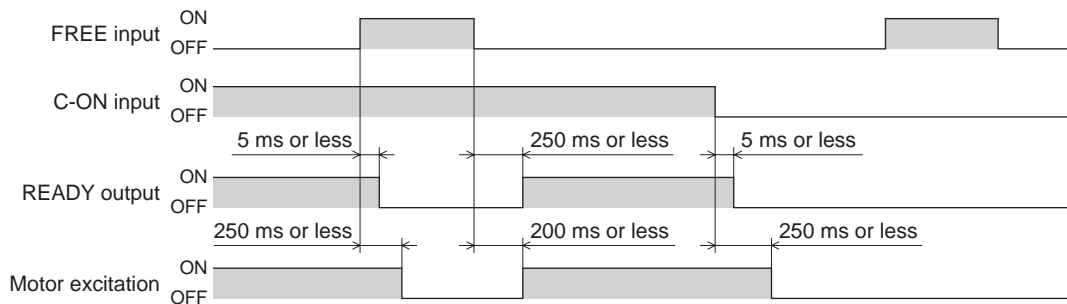

■ P-RESET input

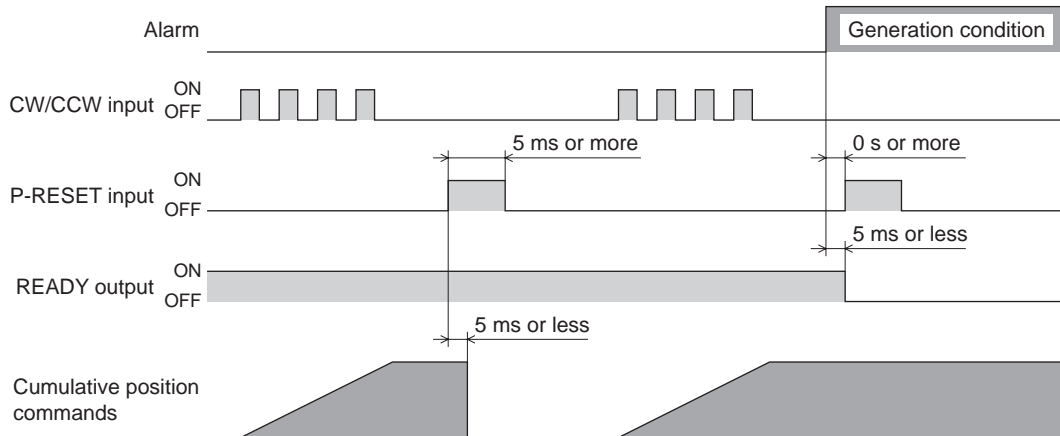

- When the P-RESET input is turned ON, the cumulative value of position commands will be reset to “0” and the current position will be set as the electrical home position.
- If an alarm generates, the P-RESET input will become invalid.
- Input the P-RESET signal while the motor is at standstill.

■ CS input

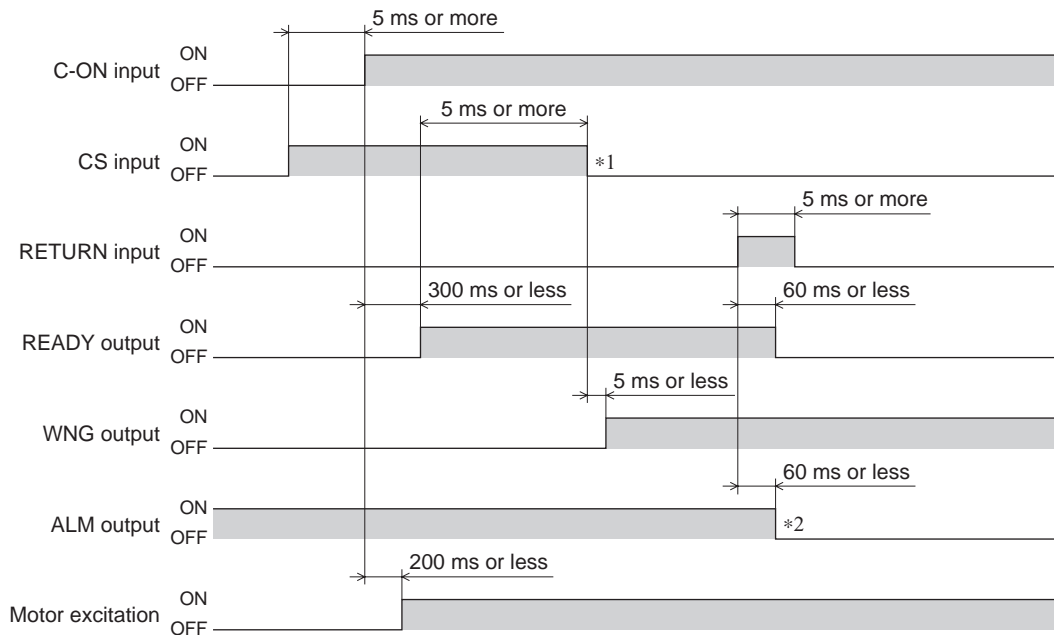

*1 If the CS input is changed while the C-ON input is ON, an abnormal operation data warning will generate.

*2 If a return to electrical home operation is performed while an abnormal operation data warning is present, an abnormal operation data alarm will generate. Note that the motor will remain excited.

- This timing chart assumes that the application parameter for abnormal operation data warning [APP-5-00] is set to “Enable.” If this parameter is set to “Disable,” no warning will be output and an alarm will generate straight away.
- Change the CS input when the motor is in a state of current OFF.

■ T-MODE input, M0 to M2 input

The motor current waveform in the following chart assumes that the standstill current is set to 50% while the push current is set to 100%.

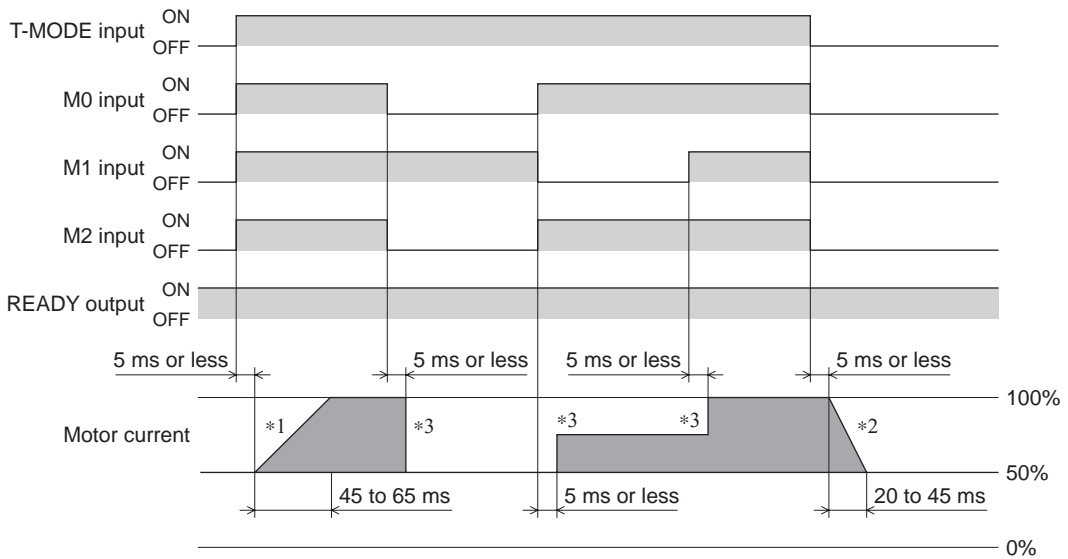

- *1 When the T-MODE input is turned ON, the motor current is changed upto the value of push current at about 0.9 %/ms.
- *2 When the T-MODE input is turned OFF, the motor current is changed upto the value of standstill current at about 1.8 %/ms.
- *3 When the value of push current is changed using the M0 to M2 inputs, the change is reflected immediately.

- The combinations of M0 to M2 inputs and corresponding initial values of push-current percentage are shown below.

M2	M1	M0	Initial value (%)
OFF	OFF	OFF	30.0
OFF	OFF	ON	40.0
OFF	ON	OFF	50.0
OFF	ON	ON	60.0
ON	OFF	OFF	70.0
ON	OFF	ON	80.0
ON	ON	OFF	90.0
ON	ON	ON	100.0

- When the T-MODE input is turned ON, the value of push current set by the M0 to M2 inputs will become effective and the overload alarm will become invalid.
- Input the T-MODE signal while the motor is at standstill.

■ CLR input

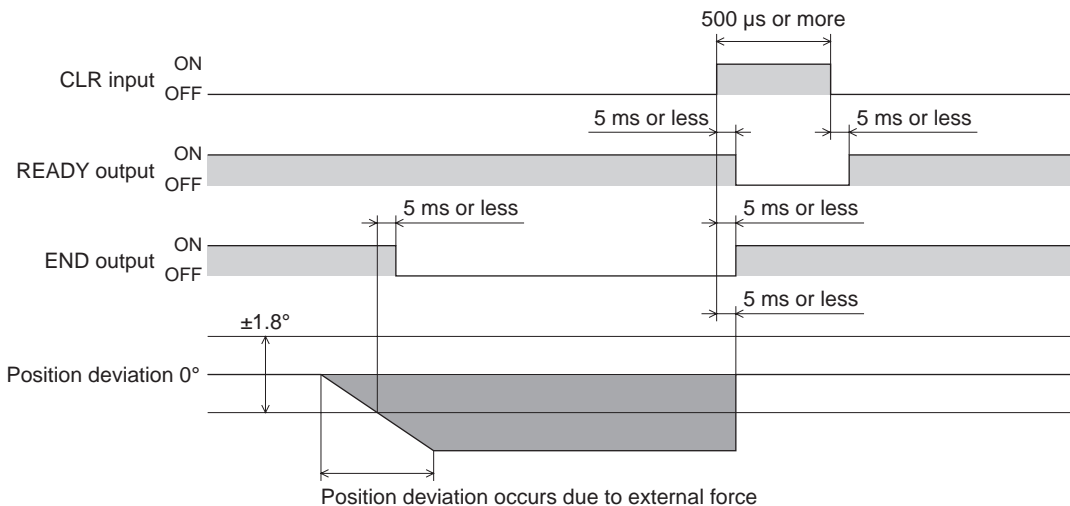

■ ALM-RST input

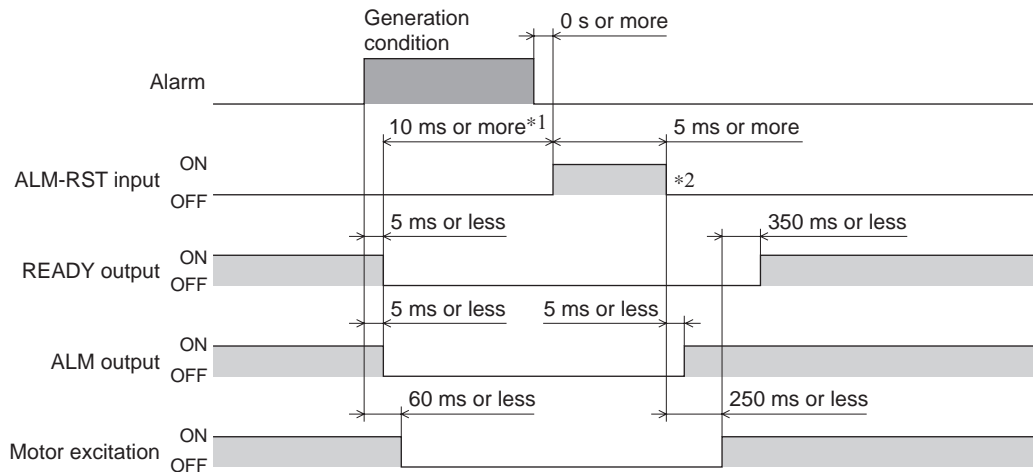

*1 The specific time varies depending on when an alarm record is saved.

*2 An alarm is reset at the OFF edge of the ALM-RST input.

- This timing chart assumes generation of an alarm that turns off motor excitation.

■ TLC output

- Normal mode

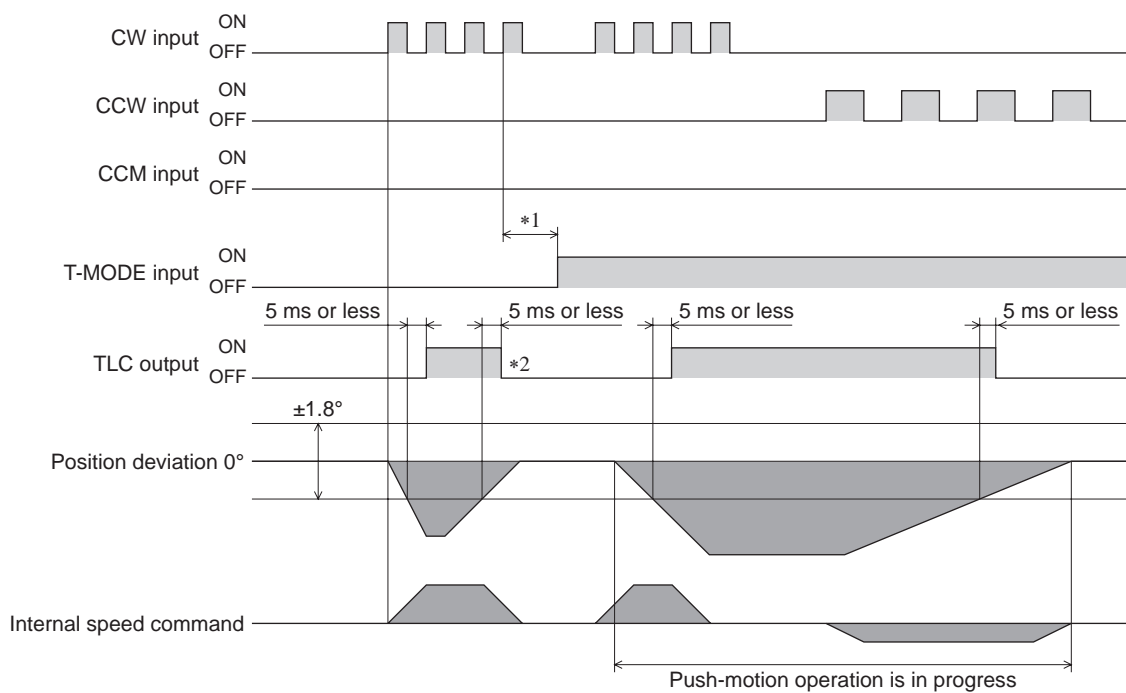

*1 Input the T-MODE signal while the motor is at standstill.

*2 When the position deviation exceeds $\pm 1.8^\circ$, the TLC signal will be output even during acceleration/deceleration.

• Current control mode

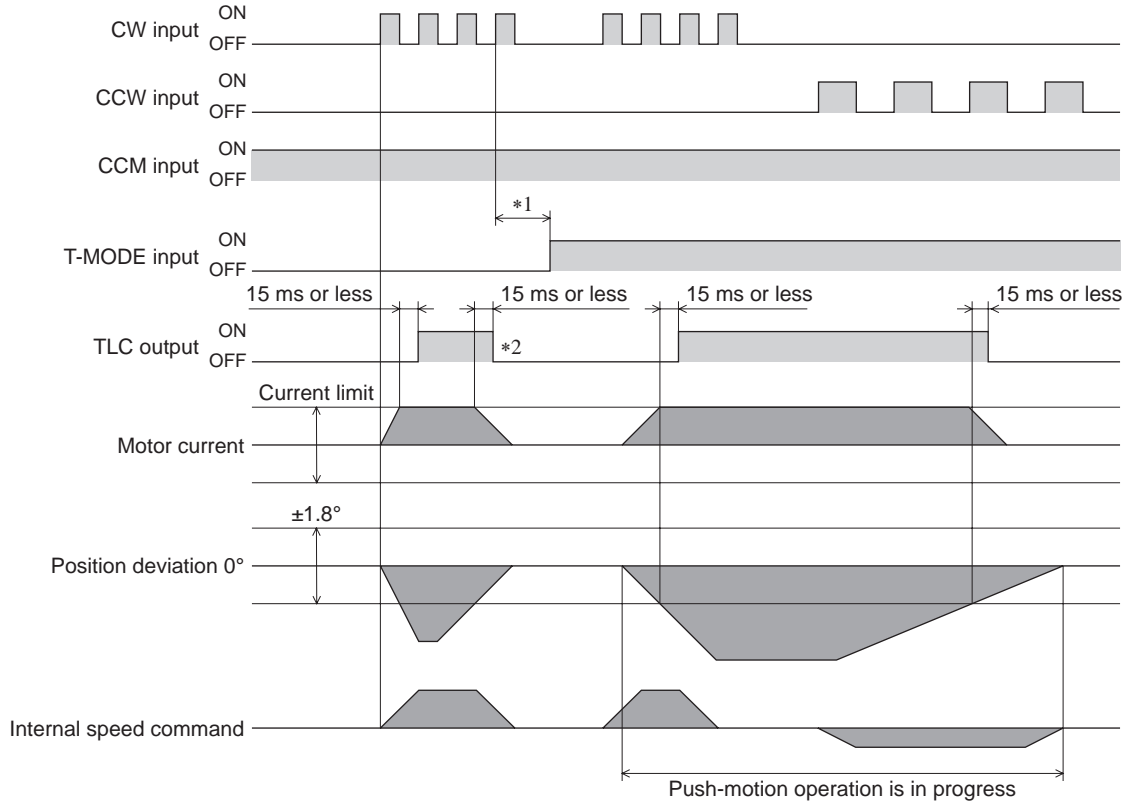

*1 Input the T-MODE signal while the motor is at standstill.

*2 When the motor current reaches the operating current, the TLC signal will be output even during acceleration/ deceleration.

■ END output

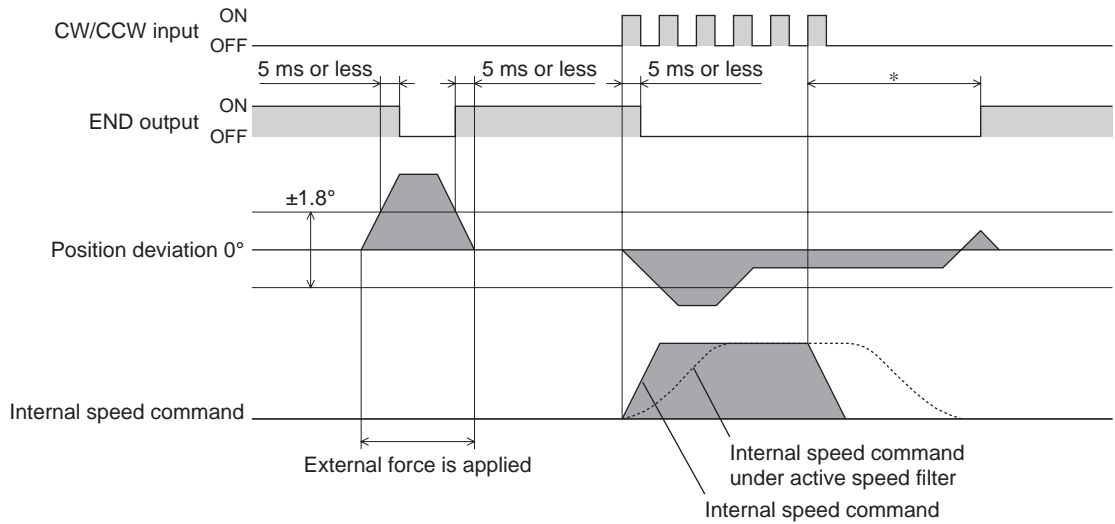

* The output time of the END signal varies depending on the speed filter and operating speed.

• The END output will turn ON when the position deviation becomes $\pm 1.8^\circ$ and internal speed command is "0."

■ TIM1 output/TIM2 output

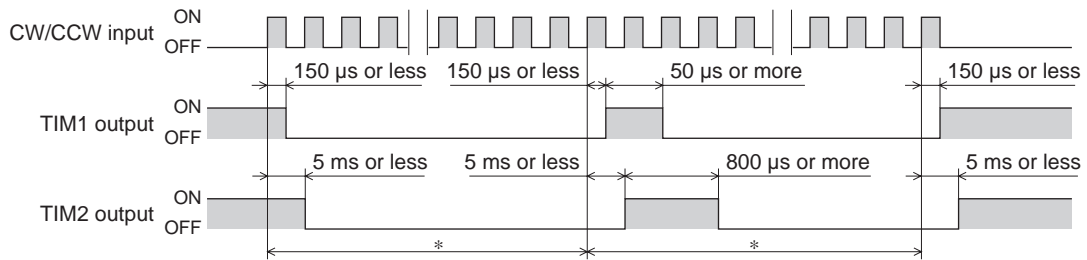

* When pulses corresponding to 1/50th the resolution are input (assuming that the resolution is a multiple of 50).

- This timing chart assumes that an operation starts from the position where the TIM output turns ON.
- The TIM1 output is a line driver output, while the TIM2 output is an open collector output.

■ Operation by pulse input

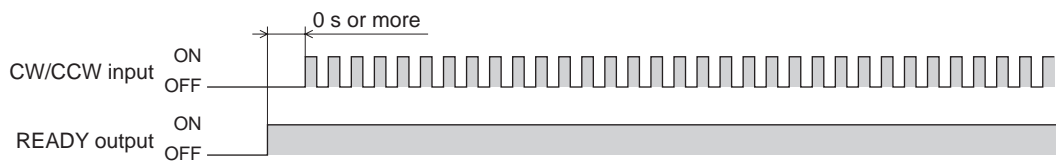

■ Return to electrical home operation

- When operation is interrupted

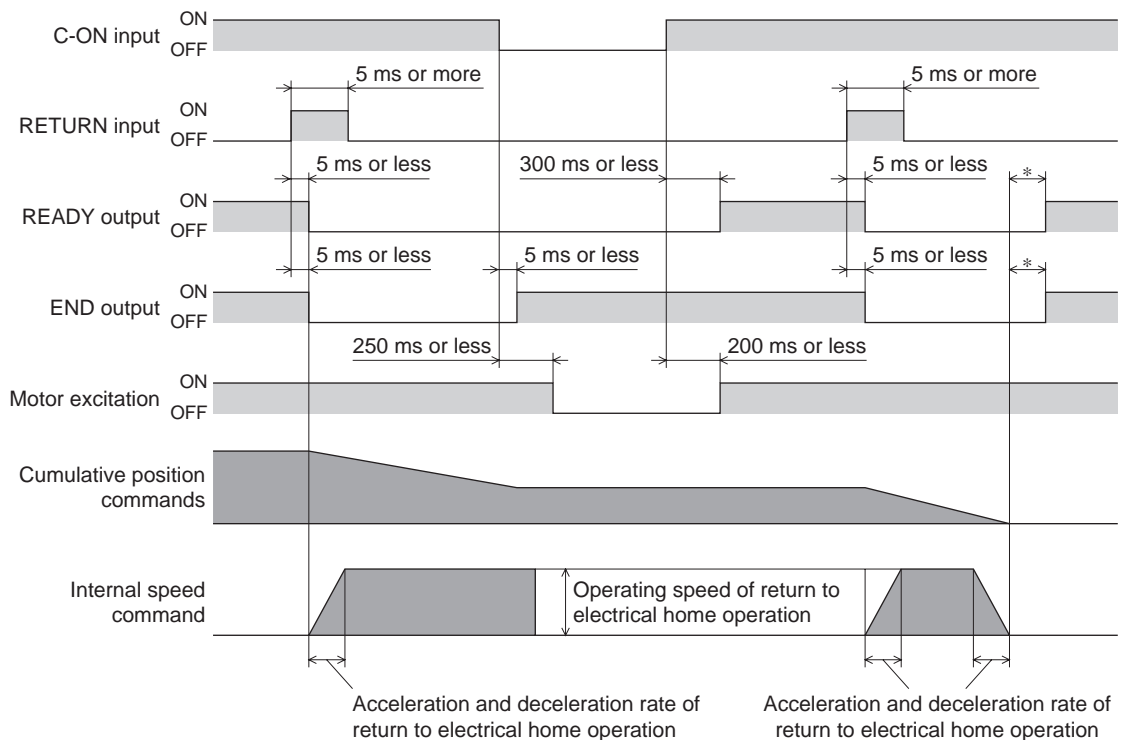

* The output time of the END signal varies depending on the speed filter and operating speed.

- If the C-ON input is turned OFF while a return to electrical home operation is still in progress, the operation will be interrupted. When the C-ON input is turned ON again and then the RETURN input is turned ON, the operation will resume from the position where it was interrupted.
- Return to electrical home operation can also be interrupted with the FREE input or CLR input. Note, however, that when a return to electrical home operation is interrupted using the CLR input, motor excitation will not turn off.

- Operation is terminated with the P-RESET input

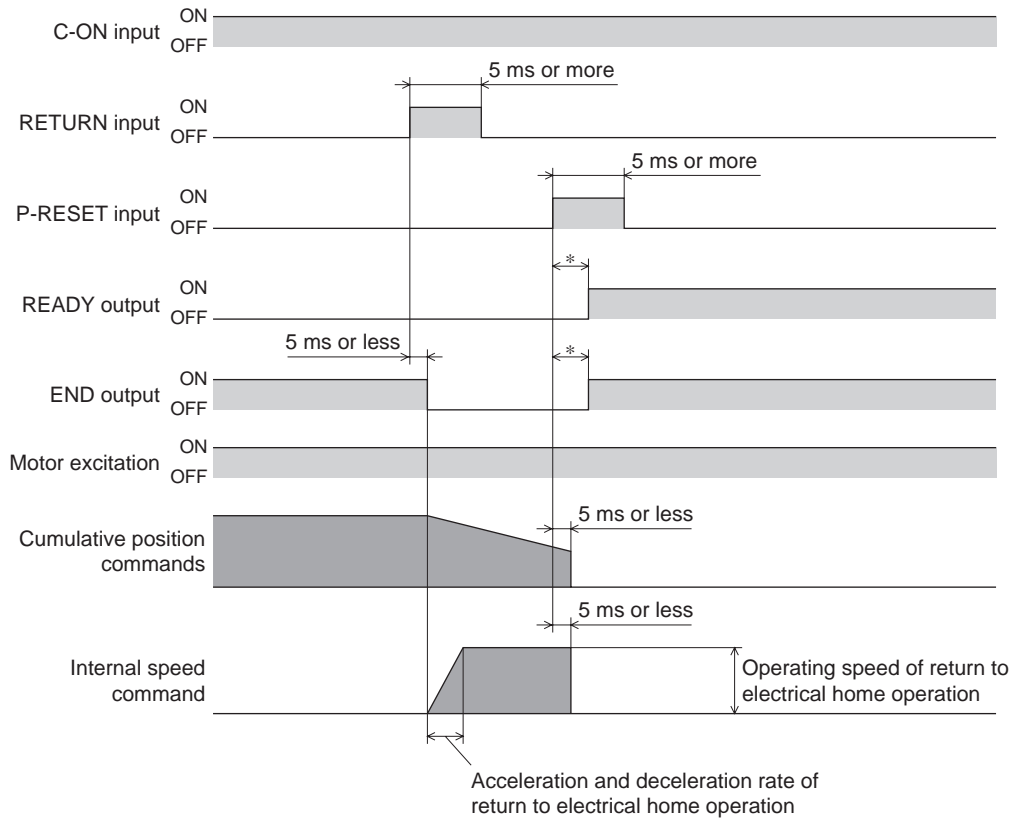

* The output time of the END signal varies depending on the speed filter and operating speed.

- When the P-RESET input is turned ON, the cumulative value of position commands will be reset to “0” and the current position will be set as the electrical home position. Accordingly, the return to electrical home operation will end.

■ Automatic return operation

- When position deviation is occurred by turning the C-ON input OFF

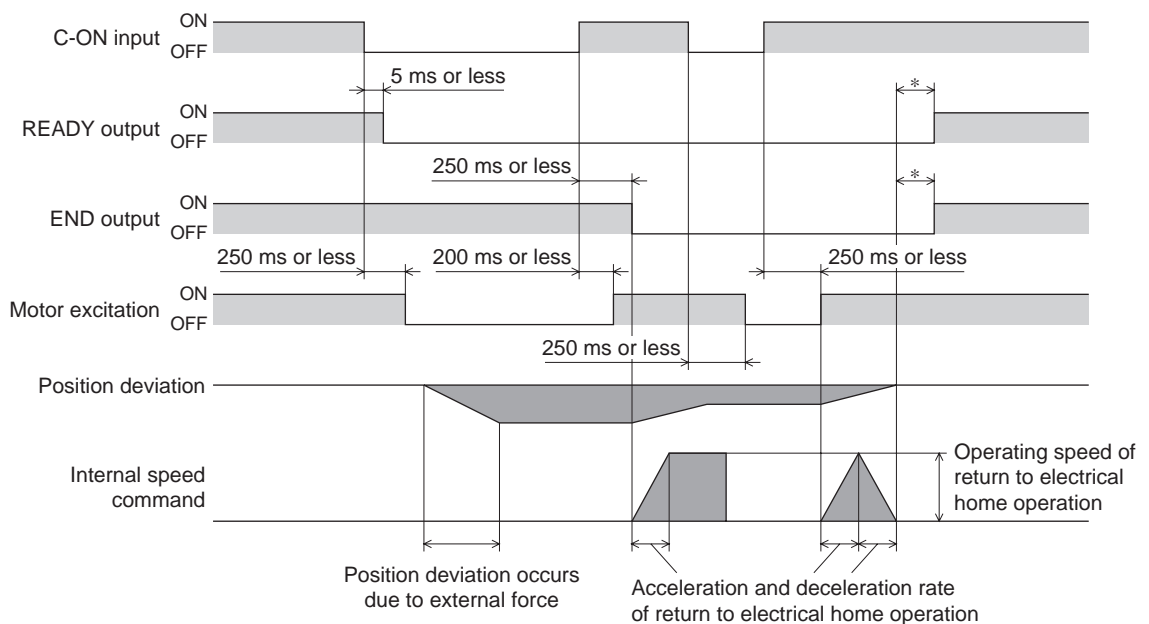

* The output time of the END signal varies depending on the speed filter and operating speed.

- If the C-ON input is turned OFF while automatic return operation is still in progress, the operation will be interrupted. When the C-ON input is turned ON again, the return operation will resume.
- Automatic return operation can also be interrupted using the FREE input.

- Operation is terminated with the CLR input

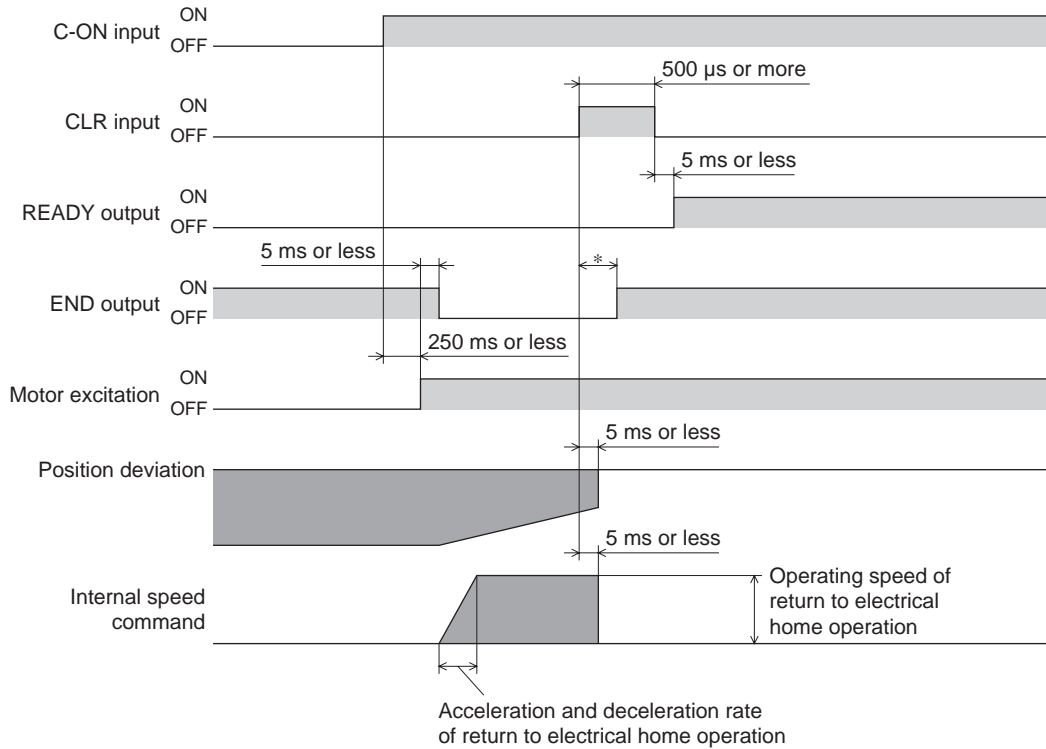

* The output time of the END signal varies depending on the speed filter and operating speed.

- When the CLR input is turned ON, the position deviation will be cleared. Accordingly, the return operation will end.

■ ALM output/WNG output

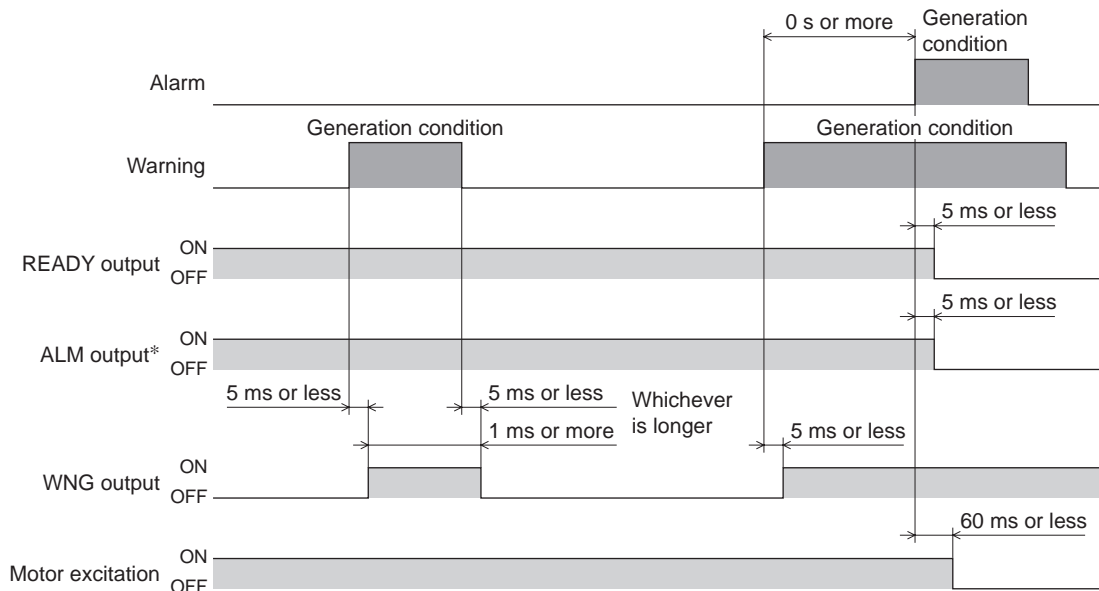

* An alarm code is also output at the same timing.

- This timing chart assumes generation of an alarm that turns off motor excitation.
- Some alarms do not turn off motor excitation.
- Some alarms are not preceded by a warning.

18.2 Function/parameter list

Item	Overview	Standard specification	Extended function	Mode	
				Normal	Current control
Control mode	Set the control mode.	○	○	○	○
Resolution	Set the resolution using the resolution switches.	○	○	○	○
	Change the electronic gear value assigned to each resolution switch. The calculated value should fall within the setting range specified below (the value of electronic gear B is common): Resolution setting range: 100 to 10,000 P/R Resolution = 1000 × (Electronic gear B / Electronic gear A1 to A4) Four resolutions can be set using different combinations of resolution switches.	×			
Operating current	Set the operating current using the current setting switch. The purpose of the setting varies depending on the control mode. Normal mode: An operating current is set. Current control mode: A current limit value used for limiting the torque and temperature rise is set.	○	○	○	○
	Change the value assigned to each dial setting of the current setting switch.	×			
Standstill current percentage setting	Set the standstill current as a percentage of the operating current.	×	○	○	×
Pulse input mode	Set the pulse input mode using the pulse input mode select switch.	○	○	○	○
	Set the pulse input mode using the applicable parameter.	×			
Motor rotation direction	Set the rotation direction of the motor.	×	○	○	○
C-ON input	Excite the motor.	○	○	○	○
	Set the logic of the C-ON input.	×			
Enable/disable of return operation to excitation position at current ON	Set whether or not to return the motor to its excitation position (where the deviation becomes "0") when the motor is in a state of current ON.	×	○	○	○
I/O input signal mode selection	Set whether or not to perform push-motion operation.	×	○	○	○

* ○: Available
×: Not available

Parameter			
OPX-2A screen display	Name	Setting range	Initial value
-	-	-	-
-	-	-	-
SyS-0-00	Electronic gear A1	1 to 1000	10
SyS-0-01	Electronic gear A2		1
SyS-0-02	Electronic gear A3		20
SyS-0-03	Electronic gear A4		2
SyS-0-04	Electronic gear B		10
-	-	-	-
APP-0-00	Operating current at CURRENT '0'	0.0 to 100.0 [%]	6.3
APP-0-01	Operating current at CURRENT '1'		12.5
APP-0-02	Operating current at CURRENT '2'		18.8
APP-0-03	Operating current at CURRENT '3'		25.0
APP-0-04	Operating current at CURRENT '4'		31.3
APP-0-05	Operating current at CURRENT '5'		37.5
APP-0-06	Operating current at CURRENT '6'		43.8
APP-0-07	Operating current at CURRENT '7'		50.0
APP-0-08	Operating current at CURRENT '8'		56.3
APP-0-09	Operating current at CURRENT '9'		62.5
APP-0-10	Operating current at CURRENT 'A'		68.8
APP-0-11	Operating current at CURRENT 'B'		75.0
APP-0-12	Operating current at CURRENT 'C'		81.3
APP-0-13	Operating current at CURRENT 'D'		87.5
APP-0-14	Operating current at CURRENT 'E'		93.8
APP-0-15	Operating current at CURRENT 'F'	100.0	
APP-3-00	Standstill current	0.0 to 50.0 [%]	50.0
-	-	-	2P
SyS-1-00	Pulse input mode	0: Setting by the pulse input mode select switch 1: 2-pulse input mode, low active 2: 2-pules input mode, high active 3: 1-pulse input mode, low active 4: 1-pules input mode, high active 5: Phase difference mode, x1 6: Phase difference mode, x2 7: Phase difference mode, x4	0
SyS-1-04	Rotation direction	0: + = CCW 1: + = CW	1
-	-	-	-
APP-2-02	C-ON input logic	0: Normally open 1: Normally closed	0
SyS-1-03	Auto return	0: Disable 1: Enable	0
APP-2-00	I/O input mode	0: Positioning operation (normal) 1: Push-motion operation	0

Item	Overview	Standard specification	Extended function	Mode	
				Normal	Current control
Alarm code	Output a corresponding alarm code using the READY/AL0 output, TLC/AL1 output and TIM2/AL2 output when an alarm generates.	x	○	○	○
Positioning completion signal range	Set the output band for END signal.	x	○	○	○
Positioning completion signal offset	Set the offset for END signal.	x	○	○	○
Pulse input operation	Perform operation based on input of CW/CCW pulses.	○	○	○	○
Push-motion operation	Set the current for push-motion operation.	x	○	○	○
	Set the input signal mode.				
	Select the current for push-motion operation using the M0 to M2 inputs.	○	○	○	
	Output the TLC signal during push-motion operation. The output condition varies depending on the control mode: Normal mode: The TLC output will turn ON when misstepping ($\pm 1.8^\circ$ or more) is detected. Current control mode: The TLC output will turn ON when the specified torque is reached.				
Setting for return to electrical home operation	Set the operating speed of return to electrical home operation.	x	○	○	○
	Set the acceleration and deceleration rate of return to electrical home operation.				
	Set the starting speed of return to electrical home operation.				
ASG/BSG output	Check the motor position.	○	○	○	○
TIM output	The TIM outputs (TIM1, TIM2) will turn ON every time the motor output shaft rotates by 7.2° .	○	○	○	○

* ○: Available
x: Not available

Parameter			
OPX-2A screen display	Name	Setting range	Initial value
APP-2-01	AL0-2 signal output	0: Disable 1: Enable	0
APP-2-03	END signal range	0.0 to 18.0 [°]	1.8
APP-2-04	END signal offset	-1.8 to 1.8 [°]	0.0
-	-	-	-
APP-2-05	Push-motion current 0	0.0 to 100.0 [%]	30.0
APP-2-06	Push-motion current 1	0.0 to 100.0 [%]	40.0
APP-2-07	Push-motion current 2	0.0 to 100.0 [%]	50.0
APP-2-08	Push-motion current 3	0.0 to 100.0 [%]	60.0
APP-2-09	Push-motion current 4	0.0 to 100.0 [%]	70.0
APP-2-10	Push-motion current 5	0.0 to 100.0 [%]	80.0
APP-2-11	Push-motion current 6	0.0 to 100.0 [%]	90.0
APP-2-12	Push-motion current 7	0.0 to 100.0 [%]	100.0
APP-2-00	I/O input mode	0: Positioning operation (normal) 1: Push-motion operation	0
-	-	-	-
-	-	-	-
APP-6-00	Operating speed of return operation	1 to 4000 [r/min]	30
APP-6-01	Acceleration and deceleration rate of return operation	0.01 to 1000.00 [ms/(1000 r/min)]	100.00
APP-6-02	Starting speed of return operation	0 to 4000 [r/min]	30
-	-	-	-
-	-	-	-

Item	Overview	Standard specification	Extended function	Mode	
				Normal	Current control
Speed filter (V-FIL) setting	Apply a filter to the operation commands using the speed filter setting switch. Adjust the filter according to the load condition.	○			
	Change the value assigned to each dial setting of the speed filter setting switch.	×	○	○	○
Adjustment in normal mode	Suppress vibration during rotation				
	Suppress vibration during operation and acceleration/deceleration.	×	○	○	×
Gain adjustment in current control mode	Adjust the position loop gain.				
	Adjust the speed loop gain.				
	Adjust the speed loop integral time constant	×	○	×	○
	Set the frequency of anti-vibration control.				
Smooth drive	Set anti-vibration control to be enabled.				
	Set the smooth drive.	×	○	○	○
JOG operation	Set the operating speed of JOG operation.				
	Set the acceleration and deceleration rate of JOG operation.	×	○	○	○
	Set the starting speed of JOG operation.				
Motor excitation position at power on	Select the position at which the motor is excited after the power has been turned on.	×	○	○	○
Data setter	Show the speed on the data setter with a sign or as an absolute value.				
	Set the gear ratio for geared motor used for speed monitor.	×	○	○	○

* ○: Available
 ×: Not available

Parameter			
OPX-2A screen display	Name	Setting range	Initial value
-	-	-	-
APP-1-00	Speed filter at V-FIL '0'	0 to 200 [ms]	0
APP-1-01	Speed filter at V-FIL '1'		1
APP-1-02	Speed filter at V-FIL '2'		2
APP-1-03	Speed filter at V-FIL '3'		3
APP-1-04	Speed filter at V-FIL '4'		5
APP-1-05	Speed filter at V-FIL '5'		7
APP-1-06	Speed filter at V-FIL '6'		10
APP-1-07	Speed filter at V-FIL '7'		20
APP-1-08	Speed filter at V-FIL '8'		30
APP-1-09	Speed filter at V-FIL '9'		50
APP-1-10	Speed filter at V-FIL 'A'		70
APP-1-11	Speed filter at V-FIL 'B'		100
APP-1-12	Speed filter at V-FIL 'C'		120
APP-1-13	Speed filter at V-FIL 'D'		150
APP-1-14	Speed filter at V-FIL 'E'		170
APP-1-15	Speed filter at V-FIL 'F'	200	
APP-3-01	Speed error gain 1	0 to 500	45
APP-3-02	Speed error gain 2		
APP-4-00	Position loop gain	1 to 50	10
APP-4-01	Speed loop gain	10 to 200	180
APP-4-02	Speed loop integral time constant	10.0 to 200.0 [ms]	100.0
APP-4-04	Frequency of anti-vibration control	3.00 to 100.00 [Hz]	7.00
APP-4-03	Anti-vibration control	0: Disable	0
SyS-1-01	Smooth drive	1: Enable	1
APP-7-00	Operating speed of JOG operation	1 to 4000 [r/min]	30
APP-7-01	Acceleration and deceleration rate of JOG operation	0.01 to 1000.00 [ms/(1000 r/min)]	100.00
APP-7-02	Starting speed of JOG operation	0 to 4000 [r/min]	30
SyS-1-02	Excite position at first current on	0: Detected position 1: Electrical angle 0°	0
APP-8-00	Displayed speed on OPX-2A	0: Signed 1: Unsigned	0
APP-8-01	Deceleration rate of speed monitor	1.0 to 100.0	1.0

18.3 Warning/alarm lists

■ Alarms (protective functions)

Item		Overview/condition
Alarm check function	LED indicator	When an alarm generates, the ALARM LED on the front face of the driver will blink. The number of times the LED blinks varies depending on the content of the alarm.
ALM output	ALM output	This signal will be output when an alarm generates.
Alarm code output	Alarm code output (AL0 to AL2 outputs)	These outputs are used by the programmable controller to detect the content of each alarm that has generated.
	Alarm code output enable/disable setting	Set when outputting alarm codes.
Alarm reset	Power cycle/reconnection	Cycle the main power to reset alarms.
	ALM-RST input	Input the ALM-RST signal to reset alarms.
Alarm detection condition setting	Excessive position deviation alarm	Set the condition under which an excessive position deviation alarm generates when the motor is in a state of current ON.
	Overload	Set the condition under which an overload detection alarm generates when the motor is in a state of current OFF. The overload condition varies depending on the control mode. Normal mode: A position deviation of 1.8° or more has occurred. Current control mode: The operating current has reached the limit.
Descriptions of alarms	Overheat protection	The internal temperature of the driver exceeded 85 °C (185 °F).
	Overload	The cumulative value of applied loads exceeding the maximum torque reached or exceeded the value set in the parameter for overload [APP-5-03].
	Overspeed	The speed of the motor output shaft exceeded 4500 r/min (excluding geared motors).
	Command pulse error	The command pulse frequency exceeded the specified value.
	Overvoltage protection	<ul style="list-style-type: none"> • A voltage exceeding the specified value was applied. • A large inertial load was operated.
	Undervoltage	The main power was cut off momentarily or the voltage became low.
	Excessive position deviation during current ON	<ul style="list-style-type: none"> • When the motor was in a state of current ON, the deviation between the command position and actual position exceeded the value set in the parameter for overflow rotation during current on [APP-5-01]. • The load is large or acceleration/deceleration rate is low.
	Excessive position deviation during current OFF	The C-ON input was turned ON while an excessive position deviation warning at current OFF was present.
	Abnormal operation data	Return to electrical home operation was performed while an abnormal operation data warning was present.
	Electronic gear setting error	The power was turned on when the resolution set by the electronic gear was outside the specified range.
	Sensor error during operation	A sensor error occurred while the motor was operating.
	Initial sensor error	A sensor error occurred when the power was turned on.
	Initial rotor rotation error	The motor output shaft rotated at a speed of 15 r/min or more while the initialization was still in progress following a power on.
	Motor combination error	A motor not supported by the driver is connected.
EEPROM error	Data stored in the driver was damaged.	

Standard specification	Extended function	Mode		Parameter			
		Normal	Current control	OPX-2A screen display	Name	Setting range	Initial value
○	○	○	○	-	-	-	-
○	○	○	○	-	-	-	-
x	○	○	○	-	-	-	-
				APP-2-01	AL0-2 signal output	0: Disable 1: Enable	0
○	○	○	○	-	-	-	-
				-	-	-	-
x	○	○	○	APP-5-01	Overflow rotation during current on	0.01 to 300.00 [rev]	3.00
				APP-5-03	Overload	0.1 to 30.0 [s]	5.0
○	○	○	○	-	-	-	-
				-	-	-	-
				-	-	-	-
				-	-	-	-
				-	-	-	-
				-	-	-	-
				-	-	-	-
				-	-	-	-
				-	-	-	-
				-	-	-	-
				-	-	-	-
				-	-	-	-
				-	-	-	-
				-	-	-	-

* ○: Available
x: Not available

■ Warnings (warning functions)

Item		Overview/condition
Warning check function	WNG output	When a warning generates, the WNG output will turn ON.
	Setting of enable/disable for return to electrical home operation warning	When the CS input is turned ON, a return to electrical home operation will be disabled and an abnormal operation data warning will generate.
Warning detection condition setting	Excessive position deviation warning	Set the condition under which an excessive position deviation warning generates when the motor is in a state of current ON.
		Set the condition under which an excessive position deviation warning generates when the motor is in a state of current OFF.
	Overvoltage warning	Set the condition under which an overvoltage warning generates.
	Undervoltage warning	Set the condition under which an undervoltage warning generates.
	Overheat warning	Set the condition under which a driver overheat warning generates.
	Overload warning	Set the condition under which an overload detection warning generates. The overload condition varies depending on the control mode. Normal mode: A position deviation of 1.8° or more has occurred. Current control mode: The operating current has reached the limit.
Overspeed warning	Set the condition under which a motor overspeed warning generates.	
Descriptions of warnings	Excessive position deviation during current ON	<ul style="list-style-type: none"> When the motor was in a state of current ON, the deviation between the command position and actual position exceeded the value set in the parameter for overflow warning rotation during current on [APP-5-04]. The load is large or acceleration/deceleration rate is too short.
	Excessive position deviation during current OFF	When the motor was in a state of current OFF, the deviation between the command position and actual position exceeded the value set in the parameter for overflow rotation during current off [APP-5-02]. (This warning is output when the parameter for auto return [SyS-1-03] is set to "Enable.")
	Overheat	The internal temperature of the driver exceeded the value set in the parameter for overheat warning [APP-5-07].
	Overvoltage	<ul style="list-style-type: none"> The voltage of the main power supply exceeded the value set in the parameter for overvoltage warning [APP-5-05]. A large inertial load was operated.
	Undervoltage	<ul style="list-style-type: none"> The voltage of the main power supply became lower than the value set in the parameter for undervoltage warning [APP-5-06]. The main power was cut off momentarily or the voltage became low.
	Overload	<ul style="list-style-type: none"> A load exceeding the maximum torque was applied for the time set in the parameter for overload warning [APP-5-08] or longer. The load is large or acceleration/deceleration rate is too short.
	Overspeed	The detected motor speed exceeded the value set in the parameter for overspeed warning [APP-5-09].
	Operation data error	<ul style="list-style-type: none"> The CS input was changed when the motor was in a state of current ON. The traveled distance from the electrical home exceeded the control range (2,147,483,648 pulses). (This alarm generates when the application parameter for abnormal operation data warning [APP-5-00] is set to "Enable.")
Electronic gear setting error	The resolution set by the electronic gear is outside the specified range.	

Standard specification	Extended function	Mode		Parameter			
		Normal	Current control	OPX-2A screen display	Name	Setting range	Initial value
x	○	○	○	-	-	-	-
				APP-5-00	Abnormal operation data warning	0: Disable 1: Enable	0
x	○	○	○	APP-5-04	Overflow rotation warning during current on	0.01 to 300.00 [rev]	3.00
				APP-5-02	Overflow rotation warning during current off		100.00
				APP-5-05	Overvoltage warning	15.0 to 63.0 [V]	63.0
				APP-5-06	Undervoltage warning		18.0
				APP-5-07	Overheat warning	40 to 85 [°C]	85
				APP-5-08	Overload warning	0.1 to 30.0 [s]	5.0
				APP-5-09	Overspeed warning	1 to 5000 [r/min]	4500
x	○	○	○	-	-	-	-
				-	-	-	-
				-	-	-	-
				-	-	-	-
				-	-	-	-
				-	-	-	-
				-	-	-	-
				-	-	-	-

* ○: Available
x: Not available

- Unauthorized reproduction or copying of all or part of this Operating Manual is prohibited.
If a new copy is required to replace an original manual that has been damaged or lost, please contact your nearest Oriental Motor branch or sales office.
- Oriental Motor shall not be liable whatsoever for any problems relating to industrial property rights arising from use of any information, circuit, equipment or device provided or referenced in this manual.
- Characteristics, specifications and dimensions are subject to change without notice.
- While we make every effort to offer accurate information in the manual, we welcome your input. Should you find unclear descriptions, errors or omissions, please contact the nearest office.
- **Orientalmotor** and **αSTEP** are registered trademark or trademark of Oriental Motor Co., Ltd., in Japan and other countries. Other product names and company names mentioned in this manual may be registered trademarks or trademarks of their respective companies and are hereby acknowledged. The third-party products mentioned in this manual are recommended products, and references to their names shall not be construed as any form of performance guarantee. Oriental Motor is not liable whatsoever for the performance of these third-party products.

© Copyright ORIENTAL MOTOR CO., LTD. 2011

- Please contact your nearest Oriental Motor office for further information.

ORIENTAL MOTOR U.S.A. CORP.
 Technical Support Tel:(800)468-3982
 8:30 A.M. to 5:00 P.M., P.S.T. (M-F)
 7:30 A.M. to 5:00 P.M., C.S.T. (M-F)
 E-mail: techsupport@orientalmotor.com
 www.orientalmotor.com

ORIENTAL MOTOR (EUROPA) GmbH
 Headquarters and Düsseldorf Office
 Tel:0211-52067-00 Fax:0211-52067-099
 Munich Office
 Tel:089-3181225-00 Fax:089-3181225-25
 Hamburg Office
 Tel:040-76910443 Fax:040-76910445

ORIENTAL MOTOR (UK) LTD.
 Tel:01256-347090 Fax:01256-347099

ORIENTAL MOTOR (FRANCE) SARL
 Tel:01 47 86 97 50 Fax:01 47 82 45 16

ORIENTAL MOTOR ITALIA s.r.l.
 Tel:02-93906346 Fax:02-93906348

SHANGHAI ORIENTAL MOTOR CO.,LTD.
 Tel:400-820-6516 Fax:021-6278-0269

TAIWAN ORIENTAL MOTOR CO.,LTD.
 Tel:(02)8228-0707 Fax:(02)8228-0708

SINGAPORE ORIENTAL MOTOR PTE LTD
 Tel:+65-6745-7344 Fax:+65-6745-9405

ORIENTAL MOTOR (MALAYSIA) SDN. BHD.
 Tel:(03)22875778 Fax:(03)22875528

ORIENTAL MOTOR (THAILAND) CO.,LTD.
 Tel:+66-2-251-1871 Fax:+66-2-251-1872

INA ORIENTAL MOTOR CO.,LTD.
 KOREA
 Tel:080-777-2042 Fax:02-2026-5495

ORIENTAL MOTOR CO.,LTD.
 Headquarters Tokyo, Japan
 Tel:03-6744-0361 Fax:03-5826-2576