

***αSTEP***

**AZ Series/**

**Motorized Actuator equipped with AZ Series  
mini Driver**

**RS-485 Communication Type**

---

**USER MANUAL**

---

Thank you for purchasing an Oriental Motor product.  
This Manual describes product handling procedures and safety precautions.

- Please read it thoroughly to ensure safe operation.
- Always keep the manual where it is readily available.

## Table of contents

<b>1</b>	<b>Introduction .....</b>	<b>3</b>	<b>8</b>	<b>ID share mode .....</b>	<b>25</b>
1-1	Before using the product.....	3	8-1	Overview of ID share mode .....	25
1-2	Operating manuals .....	3	8-2	Flow of setting of ID share mode.....	27
1-3	Overview of the product.....	5	8-3	Setting of share group.....	28
1-4	System configuration .....	5	8-4	Setting of data to be read or written .....	30
<b>2</b>	<b>Safety precautions .....</b>	<b>6</b>	8-5	Executing read/write.....	36
<b>3</b>	<b>Precautions for use.....</b>	<b>8</b>	<b>9</b>	<b>Addresses and codes lists .....</b>	<b>45</b>
<b>4</b>	<b>Preparation .....</b>	<b>10</b>	9-1	Addresses and codes specific to the mini Driver.....	45
4-1	Checking the product .....	10	9-2	Addresses and codes not compatible with the mini Driver .....	51
4-2	How to identify the product model .....	10	9-3	I/O signals assignment list.....	52
4-3	Products possible to combine .....	10	<b>10</b>	<b>Inspection and maintenance .....</b>	<b>55</b>
4-4	Information about nameplate .....	10	10-1	Inspection.....	55
4-5	Names and functions of parts.....	11	10-2	Warranty.....	55
4-6	Indication of LEDs.....	12	10-3	Disposal.....	55
<b>5</b>	<b>Installation .....</b>	<b>13</b>	<b>11</b>	<b>Troubleshooting .....</b>	<b>56</b>
5-1	Location for installation.....	13	11-1	Detection of communication errors .....	56
5-2	Installation method .....	13	11-2	Alarm.....	58
<b>6</b>	<b>Connection .....</b>	<b>15</b>	11-3	Information .....	59
6-1	Connection example.....	15	11-4	Troubleshooting and remedial actions ..	60
6-2	Connecting the main power supply and the control power supply (CN1) .....	16	<b>12</b>	<b>Cables .....</b>	<b>62</b>
6-3	Connecting the RS-485 communication cable (CN3).....	18	12-1	Connection cables (For cable type).....	62
6-4	Connecting the USB cable.....	20	12-2	Connection cables (For connector type) .....	65
6-5	Noise elimination measures .....	20	12-3	RS-485 communication cables .....	66
6-6	Compliance with the EMC Directive/Regulations .....	20	12-4	Power supply cable.....	67
<b>7</b>	<b>Setting of switches .....</b>	<b>22</b>	<b>13</b>	<b>Reference materials .....</b>	<b>68</b>
7-1	Protocol.....	22	13-1	Timing chart .....	68
7-2	Transmission rate.....	22	13-2	Specifications .....	70
7-3	Address number (server address) .....	23	13-3	Regulations and standards.....	70
7-4	Termination resistor .....	24			

# 1 Introduction

## 1-1 Before using the product

Only qualified personnel of electrical and mechanical engineering should work with the product. Use the product correctly after thoroughly reading the section "2 Safety precautions" on p.6. In addition, be sure to observe the contents described in warning, caution, and note in this manual. The product described in this manual is designed and manufactured to be incorporated in general industrial equipment. Do not use for any other purpose. Oriental Motor Co., Ltd. is not responsible for any compensation for damage caused through failure to observe this warning.

## 1-2 Operating manuals

### ■ Related operating manuals

For operating manuals, download from Oriental Motor Website Download Page or contact your nearest Oriental Motor sales office.

- **AZ** Series/ Motorized Actuator equipped with **AZ** Series mini Driver RS-485 Communication Type USER MANUAL (this document)
- **AZ** Series/Motorized Actuator equipped with **AZ** Series OPERATING MANUAL Function Edition

Read the following operating manuals for motors and motorized actuators.

- OPERATING MANUAL Motor Edition
- OPERATING MANUAL Actuator Edition
- Motorized Actuator OPERATING MANUAL Function Setting Edition

### ■ How to use operating manuals

To use the product, read this manual together with the **AZ** Series OPERATING MANUAL Function Edition. This manual describes contents specific to the mini Driver RS-485 communication type, and the **AZ** Series OPERATING MANUAL Function Edition describes contents common to the **AZ** Series products. Refer to the **AZ** Series OPERATING MANUAL Function Edition for the contents not included in this manual. For each control method, reference destinations are indicated according to the flow of use.

#### ● How to read reference destinations

The title name of the operating manual is described in the reference destination.



The title number described in the reference destination may be changed. Use the title name when checking the reference destination.

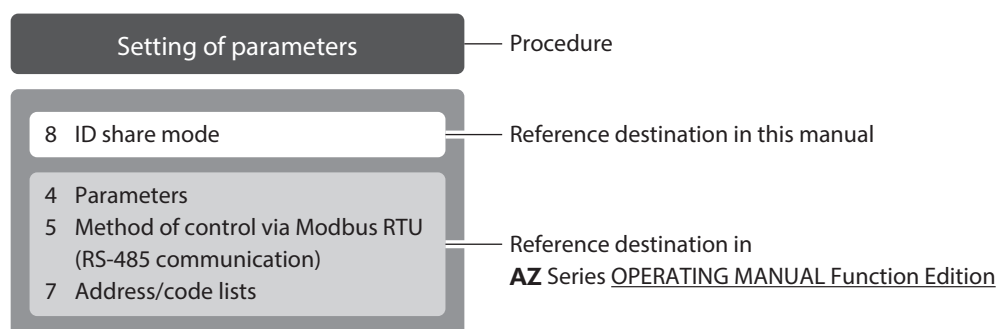

● When controlling with Modbus RTU (RS-485 communication)

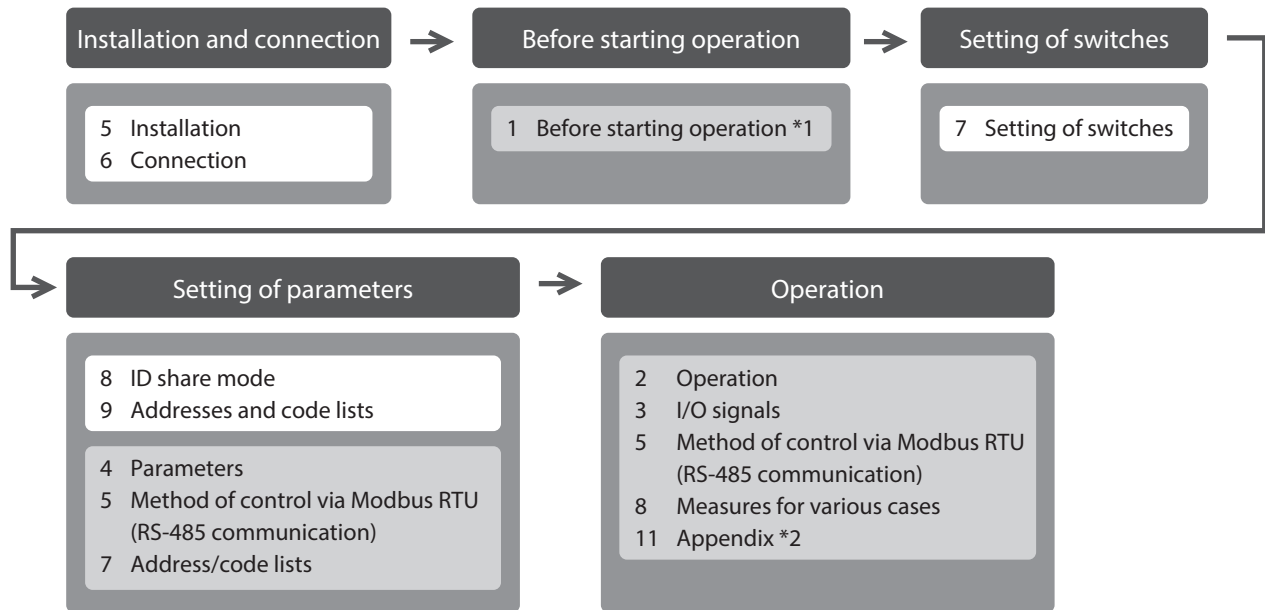

\*1 When a motorized actuator is used, the following contents cannot be operated via RS-485 communication. Use the support software **MEXE02**.

- Copying the fixed value (parameter) of the ABZO sensor to driver
- Creation of recovery data file and method of recovery

\*2 Refer to this manual for “LEDs of the driver.” (⇒ p.12)

● When controlling via industrial network

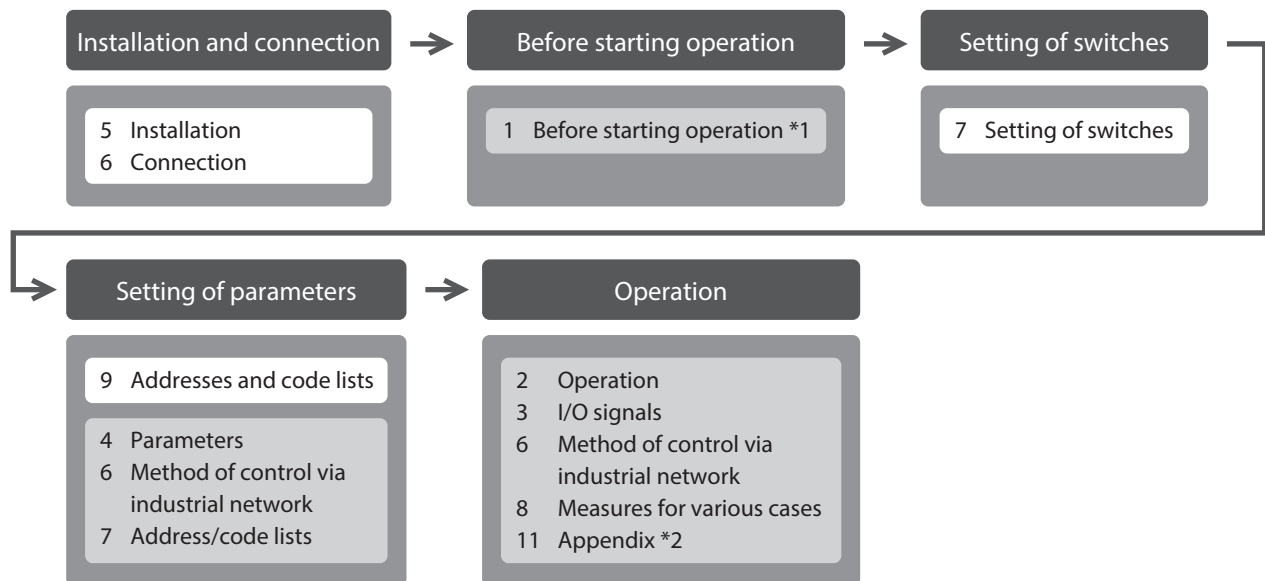

\*1 When a motorized actuator is used, the following contents cannot be operated via industrial network. Use the support software **MEXE02**.

- Copying the fixed value (parameter) of the ABZO sensor to driver
- Creation of recovery data file and method of recovery

\*2 Refer to this manual for “LEDs of the driver.” (⇒ p.12)

■ Description of power supplies

This manual describes contents when a main power supply and a control power supply are used.

The mini Driver can also be used with a main power supply only.

When using it with only the main power supply, replace “main power supply and control power supply” or “control power supply” with “main power supply” to read this manual.

## 1-3 Overview of the product

The **AZ** Series mini Driver RS-485 communication type is the dedicated driver for the **AZ** Series products.

- **Compact and light weight**

Compact and lightweight are achieved, offering the dimensions of 47×53×24 mm (1.85×2.09×0.94 in.) and the mass of 56 g (1.98 oz.).

- **Compatible with network communications**

With Modbus RTU (RS-485 communication) or via industrial networks using an Oriental Motor's network converter, operation data and parameters can be set, and also executing and stopping operation can be controlled. Operation data and parameters can also be set using the support software **MEXE02**.

## 1-4 System configuration

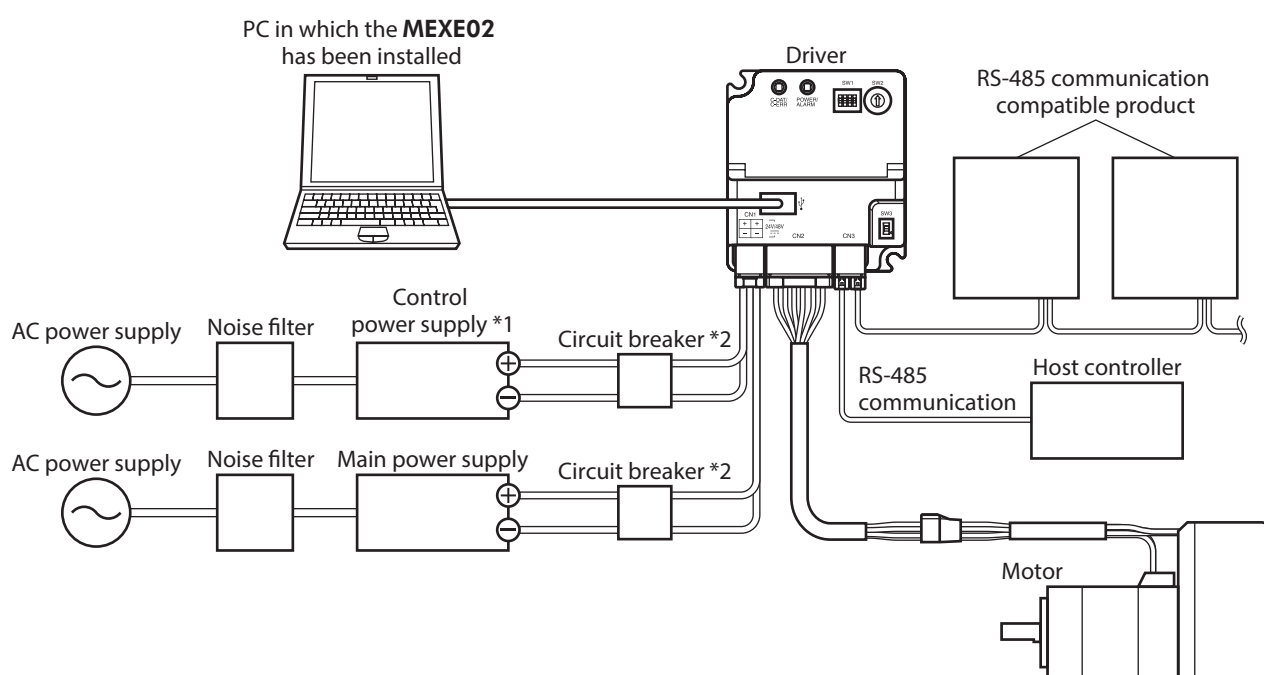





\*1 Connecting the control power supply allows you to continue monitoring even if the main power supply is shut off. Connect it as necessary.

\*2 It is recommended that a circuit breaker or a circuit protector is connected because incorrect wiring may cause the internal input circuit to short-circuit.

## 2 Safety precautions

The precautions described below are intended to ensure the safe and correct use of the product, and to prevent the user and other personnel from exposure to the risk of injury. Use the product only after carefully reading and fully understanding these instructions.

 <b>WARNING</b>	Handling the product without observing the instructions that accompany a “WARNING” symbol may result in serious injury or death.
 <b>CAUTION</b>	Handling the product without observing the instructions that accompany a “CAUTION” symbol may result in injury or property damage.
	The items under this heading contain important handling instructions that the user should observe to ensure safe use of the product.
	The items under this heading contain related information and contents to gain a further understanding of the text in this manual.

### **WARNING**

#### General

- Do not use the product in explosive or corrosive environments, in the presence of flammable gases, locations subjected to splashing water, or near combustibles. Doing so may result in fire, electric shock, or injury.
- Assign qualified personnel to the task of installing, wiring, operating/controlling, inspecting and troubleshooting the product. Handling by unqualified personnel may result in fire, electric shock, injury or damage to equipment.
- Do not transport, install, connect or inspect the product while the power is supplied. Doing so may result in electric shock.
- Do not touch the driver while the power is on. Doing so may result in fire or electric shock.
- When the driver generates an alarm (any of the driver's protective functions is triggered), first remove the cause and then clear the protective function. Continuing the operation without removing the cause of the problem may cause malfunction of the motor and driver, leading to injury or damage to equipment.

#### Installation

- Install the driver in an enclosure. Failure to do so may result in electric shock or injury.

#### Connection

- Keep the input power voltage of the driver within the product specifications. Failure to do so may result in fire or electric shock.
- Connect the product securely according to the wiring diagram. Failure to do so may result in fire or electric shock.
- Do not forcibly bend, pull, or pinch the connection cable. Doing so may result in fire or electric shock.

#### Operation

- Turn off the main power supply and control power supply in the event of a power failure. Failure to do so may result in injury or damage to equipment.
- Do not remove the motor excitation during operation. Doing so may cause the motor to stop and lose the holding force, resulting in injury or damage to equipment.

#### Repair, disassembly and modification

- Do not disassemble or modify the driver. Doing so may result in injury or damage to equipment.

 **CAUTION****General**

- Do not use the driver beyond the specifications. Doing so may result in electric shock, injury, or damage to equipment.
- Keep your fingers and objects out of the openings in the driver. Failure to do so may result in fire, electrical shock, or injury.
- Do not touch the driver while operating or immediately after stopping. Doing so may result in a skin burn(s).
- Do not forcibly bend or pull the cable that is connected to the driver. Doing so may cause damage to the product.

**Installation**

- Keep the area around the driver free of combustible materials. Failure to do so may result in fire or a skin burn(s).
- Do not leave anything around the driver that would obstruct ventilation. Doing so may result in damage to equipment.

**Operation**

- Use a motor and a driver only in the specified combination. An incorrect combination may cause a fire.
- Take measures against static electricity when operating the switches of the driver. Failure to do so may result in the driver malfunction or damage to equipment.
- Provide an emergency-stop device or emergency-stop circuit external to the equipment so that the entire equipment will operate safely in the event of a system failure or malfunction. Failure to do so may result in injury.
- When moving the moving part by hands, put the motor into a non-excitation state. Operating in a state where the motor is excited may cause injury.
- For the main power supply and control power supply, use a DC power supply with reinforced insulation on its primary and secondary sides. Failure to do so may result in electric shock.
- When an abnormal condition has occurred, immediately stop operation to turn off the main power supply and control power supply. Failure to do so may result in fire, electrical shock, or injury.

## 3 Precautions for use

This chapter explains restrictions and requirements the user should consider when using the product.

- **Always use Oriental Motor cables to connect a motor and a driver.**

Refer to the cable models on p.62.

- **When conducting the insulation resistance measurement or the dielectric strength test, be sure to separate the connection between the motor and the driver.**

Conducting the insulation resistance measurement or dielectric strength test with the motor and driver connected may result in damage to the product.

- **Note when connecting a main power supply and a control power supply in a state of grounding the positive side**

The USB communication connector, CN1, and CN2 connectors on the driver are not electrically insulated. When grounding the positive terminals of a main power supply and a control power supply, do not connect any equipment (PC, etc.) whose negative terminal is grounded. Doing so may cause the driver and this equipment to short, damaging both. When connecting, do not ground equipment.

- **Saving data to the non-volatile memory**

Do not turn off the control power supply while writing the data to the non-volatile memory, and also do not turn off for five seconds after the completion of writing the data. Doing so may abort writing the data and cause an alarm of EEPROM error to generate. The non-volatile memory can be rewritten approximately 100,000 times.

- **Noise elimination measures**

Refer to p.20 for the noise elimination measures.

- **Regeneration**

When operating a large load inertia at a high speed, the regenerative energy generated may increase the voltage of the main power supply, causing an alarm of the overvoltage to generate. To prevent damage to the driver, reconsider the operating conditions so that regenerative voltage does not generate.

- **Static electricity measures for the driver**

The driver uses components that are sensitive to static electricity. Take measures against static electricity since static electricity may cause the driver to malfunction or suffer damage.

### ■ Notes when the connection cable is used

Note the following points when an Oriental Motor cable is used.

- **When inserting the connector**

Hold the connector main body, and insert it in straight securely. Inserting the connector in an inclined state may result in damage to terminals or a connection failure.

- **When pulling out the connector**

Pull out the connector in straight while releasing the lock part of the connector. Pulling out the connector with holding the cable may result in damage to the connector.

- **Bending radius of cable**

- Use the cable in a condition where the bending radius of the cable is as follows.

Cable type: More than 6 times the cable diameter

Connector type: More than 2.8 times the cable diameter

- Do not bend the lead wires part or secure with a clamp, etc. Doing so may result in damage to the connector.

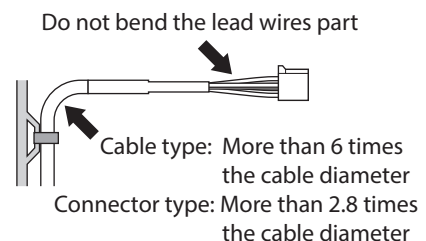

- **How to fix the cable**

Fix the cable near the connectors at two places as shown in the figure or fix it with a wide clamp to take measures to prevent stress from being applied to the connectors.

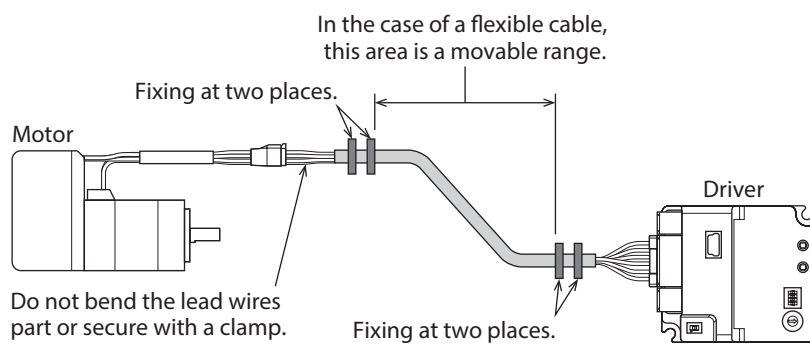

## 4 Preparation

### 4-1 Checking the product

Verify that the items listed below are included. Report any missing or damaged items to the Oriental Motor sales office from which you purchased the product.

- Driver ..... 1 unit
- Instructions and Precautions for Safe Use ..... 1 copy

### 4-2 How to identify the product model

Check the driver model against the model shown on the nameplate. Refer to "4-4 Information about nameplate" for how to identify the nameplate.

**AZD** - **K** **R** **2** **D**  
 1            2    3    4    5

1	Series	<b>AZD: AZ Series driver</b>
2	Power supply input	<b>K: DC power input</b>
3	Driver figure	<b>R: Compact</b>
4	Reference number	
5	Type	<b>D: RS-485 communication type</b>

### 4-3 Products possible to combine

Products with which the driver can be combined are listed below. Check the model name of the product with the nameplate.

Power supply type	Product type	Applicable Series	Model name representing Series name *1	Example of model name
DC power input	Stepping motor	<b>AZ Series</b>	<b>AZM</b>	<b>AZM46AK</b>
	Motorized actuator	<b>EAC Series *2</b>	<b>EACM</b>	<b>EACM2E05AZAK</b>
		<b>EAS Series *2</b>	<b>EASM</b>	<b>EASM4NXD005AZAK</b>
		<b>EZS Series *2</b>	<b>EZSM</b>	<b>EZSM6D005AZAK</b>
		<b>DR Series</b>	<b>DR</b>	<b>DR28G2.5B03-AZAKU</b>
		<b>DRS2 Series</b>	<b>DRSM</b>	<b>DRSM60-05A4AZAK</b>
		<b>DGII Series *2</b>	<b>DGM</b> <b>DGB</b> <b>DGR</b>	<b>DGM85R-AZAK</b> <b>DGB85R12-AZAKR</b> <b>DGR85R36-AZAKHR</b>
		<b>EH Series *2</b>	<b>EH</b>	<b>EH4-AZAKH</b>
<b>L Series *2</b>	<b>LM</b>	<b>LM4F150AZAK-1</b>		

\*1 The driver described in this manual can be combined with products that begin with these model names.

\*2 For these motorized actuators, the equipped motors have been evaluated to affix the CE Marking. The model name of the equipped motor can be checked as follows.

**EAC Series, EAS Series, EZS Series:** Check with the motor nameplate.

**DGII Series, EH Series, L Series:** Check with "P/N (Motor P/N)" described on the actuator nameplate.

### 4-4 Information about nameplate

The figure shows an example.

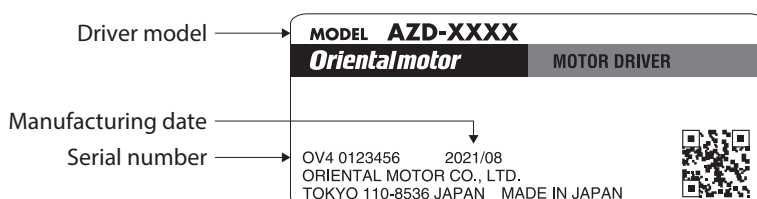

## 4-5 Names and functions of parts

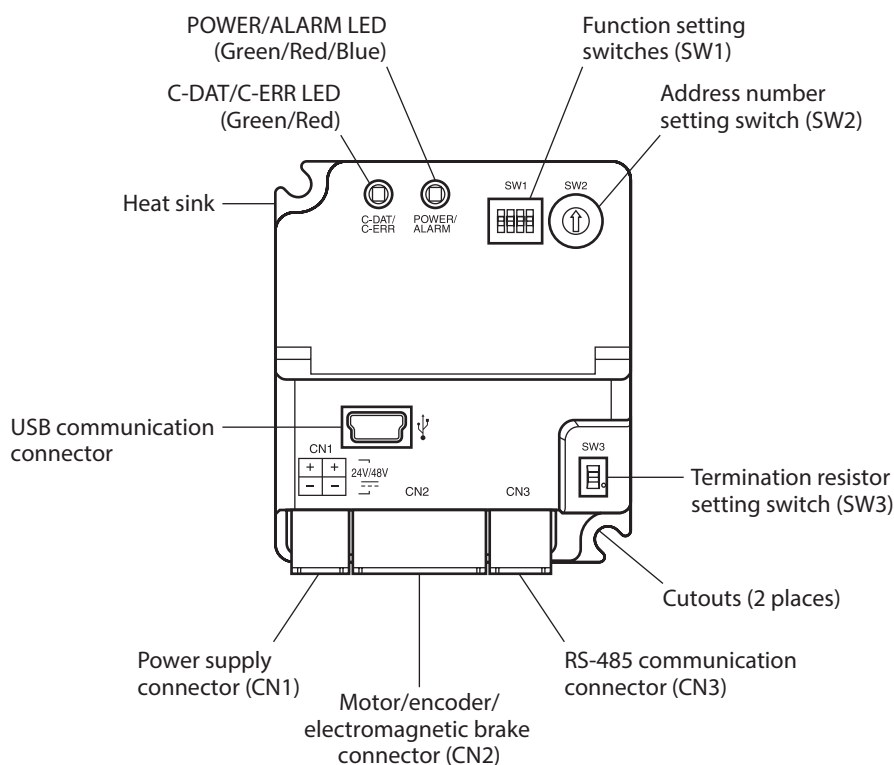

Type	Name	Description
LED	C-DAT/C-ERR LED (Green/Red)	This LED indicates the status of RS-485 communication.
	POWER/ALARM LED (Green/Red/Blue)	This LED indicates the status of the driver.
Switch	Function setting switches (SW1)	<ul style="list-style-type: none"> <li>• No.1: Sets the address number (server address) of RS-485 communication using together with the address number setting switch (SW2). Factory setting: OFF</li> <li>• No.2: Sets the RS-485 communication protocol. Factory setting: ON</li> <li>• No.3: Sets the transmission rate of RS-485 communication. Factory setting: ON</li> <li>• No.4: Not used.</li> </ul>
	Address number setting switch (SW2)	Sets the address number (server address) of RS-485 communication using together with the function setting switch SW1-No.1. Factory setting: 1
	Termination resistor setting switch (SW3)	Sets the termination resistor (120 Ω) of RS-485 communication. Factory setting: OFF
Connector	Power supply connector (CN1)	Connects a main power supply and a control power supply.
	Motor/encoder/electromagnetic brake connector (CN2)	Connects the motor, encoder, and electromagnetic brake.
	RS-485 communication connector (CN3)	Connects the RS-485 communication cable.
	USB connector 	Connects a PC in which the <b>MEXE02</b> has been installed. (USB2.0 mini-B port)

## 4-6 Indication of LEDs

The status of the driver and RS-485 communication can be checked using the indication of LEDs.



The lighting colors of the POWER/ALARM LED and the C-DAT/C-ERR LED can be changed from green to white using the "LED (PWR/C-DAT) color changing" parameter.

### ■ POWER/ALARM LED

This LED indicates the status of the driver.

LED status	Description
No light	The main power supply and the control power supply are not turned on.
Green light	The main power supply and/or the control power supply are turned on.
Blinking red	An alarm is being generated. The alarm message generated can be checked by counting the number of times the LED blinks. The LED is lit in green when the alarm is reset.
Blinking blue	Information is being generated. The LED is lit in green when the information is cleared.
Repeating "Green → Red → Simultaneously lit * → No light"	This is the driver simulation mode.

\* Green and red colors may overlap and it may be visible to yellow.

### ■ C-DAT/C-ERR LED

This LED indicates the status of RS-485 communication.

LED status	Description
Green light or blinking green	The driver communicates with the host controller properly via RS-485 communication.
Red light	An error occurs in communication with the host controller via RS-485 communication. The LED will be lit or blink in green when the communication status returns to the normal state.

# 5 Installation

## 5-1 Location for installation

The driver is designed and manufactured to be incorporated in equipment. Install it in a well-ventilated location that provides easy access for inspection. The location must also satisfy the following conditions:

- Inside an enclosure that is installed indoors (provide vent holes)
- Operating ambient temperature: 0 to +50 °C [+32 to +122 °F] (non-freezing)
- Operating ambient humidity: 85 % or less (non-condensing)
- Area free of explosive atmosphere, toxic gas (such as sulfuric gas), or liquid
- Area not exposed to direct sun
- Area free of excessive amount of dust, iron particles or the like
- Area not subject to splashing water (rain, water droplets), oil (oil droplets) or other liquids
- Area free of excessive salt
- Area not subject to continuous vibration or excessive shocks
- Area free of excessive electromagnetic noise (from welders, power machinery, etc.)
- Area free of radioactive materials, magnetic fields or vacuum
- Up to 1,000 m (3,300 ft.) above sea level

## 5-2 Installation method

The driver can be installed in any direction.

Install the driver onto a flat metal plate offering high heat conductivity [material: aluminum, 150×150×2 mm (5.91×5.91×0.08 in.) or equivalent].

When installing the driver, use the cutouts for mounting and secure to the metal plate with two screws (M3; not included).

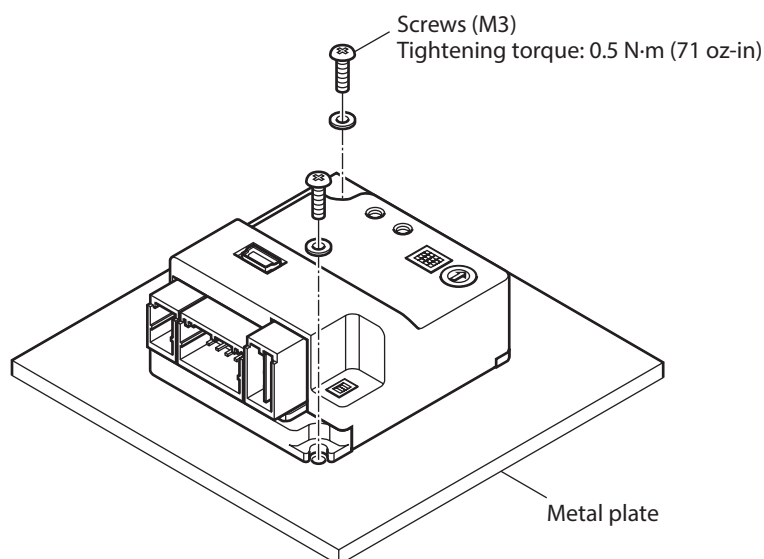

### Note

- Install the driver in an enclosure.
- Do not install any equipment that generates a large amount of heat or noise near the driver.
- Do not install the driver underneath a host controller or other equipment sensitive to heat.
- If the ambient temperature of the driver exceeds 50 °C (122 °F), reconsider the ventilation conditions such as providing forced cooling by using fans.

■ **Dimensions [Unit: mm (in.)]**

Mass: 56 g (1.98 oz.)

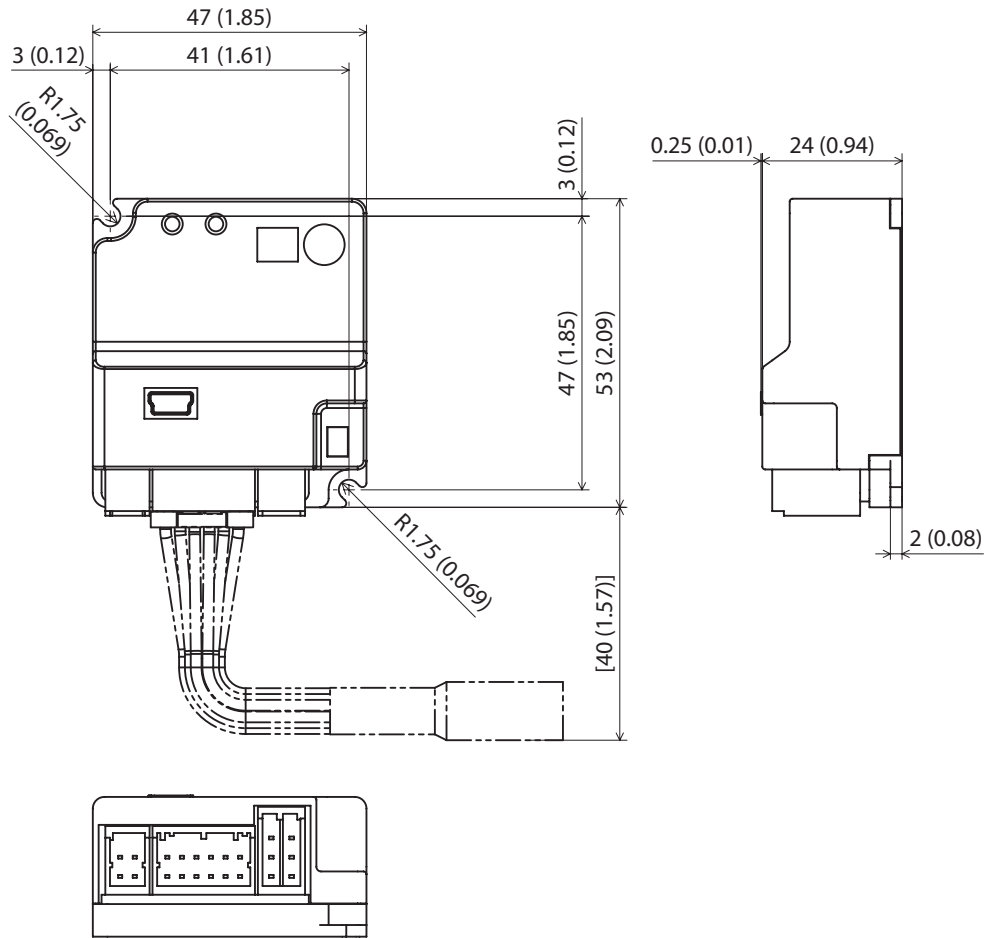

# 6 Connection

This chapter explains a connection example of a driver and a motor, connection methods of a main power supply and a control power supply, and others. It also explains installation and wiring methods to conform to the EMC Directive/Regulations as well as measures against electrical noise.

## 6-1 Connection example

The figure shows an example when the **AZM14** motor is connected.

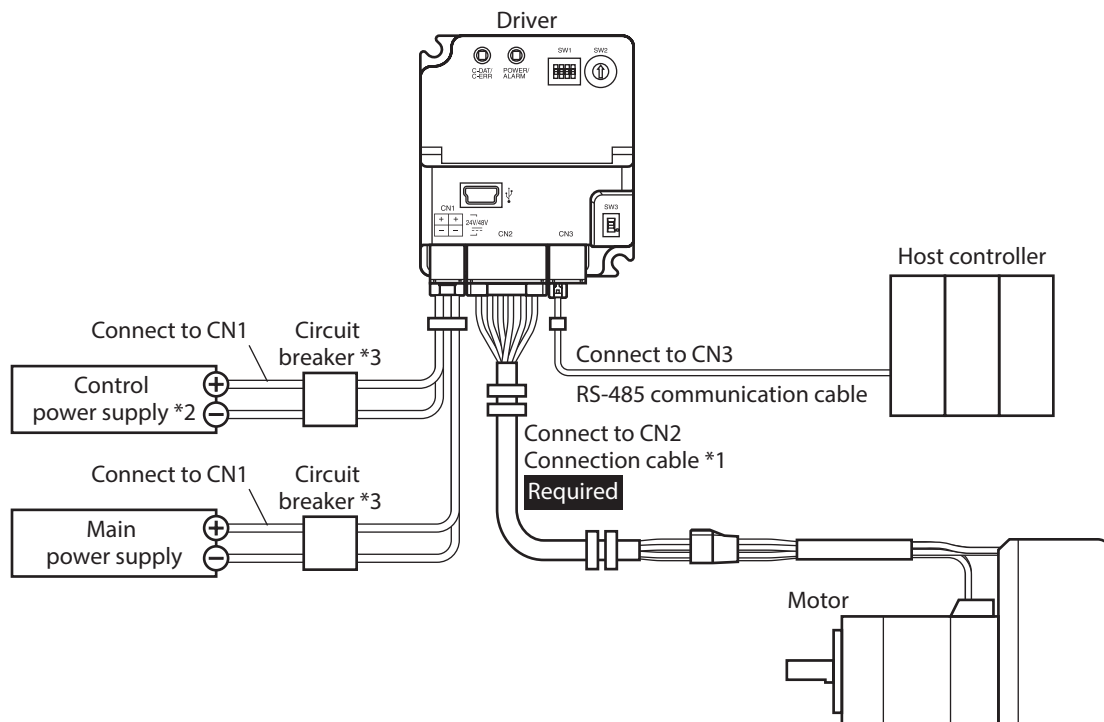

\*1 It is an Oriental motor cable. Purchase is required separately.

\*2 Connecting the control power supply allows you to continue monitoring even if the main power supply is shut off. Connect it as necessary.

\*3 It is recommended that a circuit breaker or a circuit protector is connected because incorrect wiring may cause the internal input circuit to short-circuit.

- Note**
- Connect the connectors securely. Insecure connections may cause malfunction or damage to the motor or driver.
  - When connecting the cables, secure them so that no load is applied to the CN1 to CN3 connectors. Applying a load to the connector may result in a connection failure, causing the driver to malfunction.
  - Keep 10 m (32.8 ft.) or less for the wiring distance between a motor and a driver. Exceeding 10 m (32.8 ft.) in the wiring distance may result in increase of the electrical noise emitted from the driver.
  - Keep 2 m (6.6 ft.) or less for the cable length of the main power supply and control power supply.

- memo**
- Before connecting or disconnecting a connector, turn off the main power supply and the control power supply, and check the POWER/ALARM LED has been turned off.
  - When disconnecting the connector, pull out while pressing the latches on the connector with fingers.
  - GND of the power supply connector and SG of the RS-485 communication connector are electrically insulated.

## 6-2 Connecting the main power supply and the control power supply (CN1)

Connect a main power supply to the CN1 connector.  
 Connecting the control power supply allows you to continue monitoring even if the main power supply is shut off.  
 Connect it as necessary.

**Note** Make sure the polarity of the power supply before connecting. Reverse-polarity connection may cause damage to the driver.

### ■ Applicable connector

Type	Part number	Applicable lead wire
Connector housing	1-1827864-2 (TE Connectivity)	AWG22 (0.34 to 0.37 mm <sup>2</sup> ) AWG20 (0.51 to 0.53 mm <sup>2</sup> ) AWG18 (0.85 to 0.87 mm <sup>2</sup> )
Contact	1827589-2 (TE Connectivity)	Lead wire insulation outer diameter: ø1.4 to 2.2 mm (ø0.055 to 0.087 in.)
Designated crimp tool	2119142-1 (TE Connectivity)	Lead wire insulation strip length: 1.7 to 2.3 mm (0.067 to 0.091 in.)

### ■ Pin assignment

The figure shows the view from the insertion side of lead wire.  
 Insert the lead wires with crimped contacts in the direction of the arrow.

Pin No.	Name	Description
B1	Control power supply	+24 VDC/+48 VDC
A1	GND	Ground for control power supply

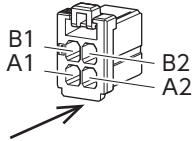

Pin No.	Name	Description
B2	Main power supply	+24 VDC/+48 VDC
A2	GND	Ground for main power supply

**memo** A1 and A2 are not electrically insulated.

### ■ Voltage specifications

The voltage specifications of power supply input include the rated voltage and the allowable operating voltage.  
 The voltage specifications are common for the main power supply and the control power supply.

Rated voltage	24 VDC±5 % 48 VDC±5 %
Allowable operating voltage	24 VDC input: 20 to 32 VDC (22.8 to 32 VDC) * 48 VDC input: 40 to 55 VDC

\* The value in parentheses ( ) is the one when the electromagnetic brake motor is connected.

**memo** Set the "main power mode" parameter to "0: 24 VDC" or "1: 48 VDC" when the main power supply starts up slowly or the voltage of the main power supply is unstable. (⇨ p.49)

### Internal input circuit

The driver can be used with the main power supply and control power supply, or with the main power supply only. When using only the main power supply, the power is supplied from the main power supply to the control power supply circuit inside the driver.

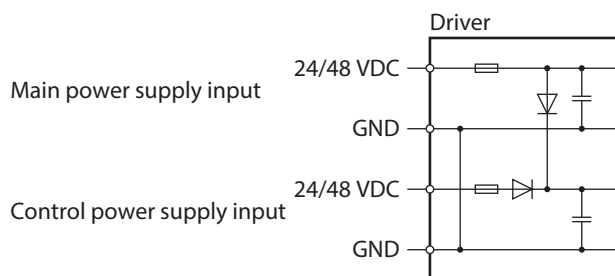

### Power supply current capacity

#### Current capacity for main power supply

The current capacity for the main power supply varies depending on the product combined. Check the current capacity in reference to the equipped motor model name when using the **EAC** Series, **EAS** Series, or **EZS** Series.

The box (□) in the model indicates an alphabet (**B**, **M**, or **R**) representing the shape of the actuator.

Series	Model	Rated voltage	Power supply current capacity
AZ Series EAC Series EAS Series EZS Series	AZM14	24 VDC±5 %	0.4 A or more
	AZM15		0.5 A or more
	AZM24, AZM26		1.4 A or more
	AZM46	24 VDC±5 % 48 VDC±5 %	1.6 A or more
	AZM48		2.1 A or more
	AZM66		3.7 A or more
	AZM69		3.5 A or more
DGII Series	DG□60	24 VDC±5 %	1.4 A or more
	DG□85	24 VDC±5 %	1.6 A or more
	DG□130	48 VDC±5 %	3.7 A or more
DR Series	DR20	24 VDC±5 %	0.4 A or more
	DR28		1.3 A or more
DRS2 Series	DRSM42	24 VDC±5 %	1.5 A or more
	DRSM60	48 VDC±5 %	2.6 A or more
EH Series	EH3	24 VDC±5 %	0.4 A or more
	EH4		1.4 A or more
L Series	LM2, LM4	24 VDC±5 % 48 VDC±5 %	3.7 A or more

#### Current capacity for control power supply

Rated voltage	Power supply current capacity	
	Without electromagnetic brake	With electromagnetic brake
24 VDC±5 % 48 VDC±5 %	0.15 A	0.4 A *

\* The **AZM46** type is 0.23 A.

## 6-3 Connecting the RS-485 communication cable (CN3)

Connect the RS-485 communication cable to the CN3 connector.

A cable to connect with the host controller and that to connect between drivers are required to be provided by the customer. Cables that connect to the network converter or the robot controller **MRC01** are provided by Oriental Motor separately. Refer to p.66 for the model name.

### ■ Applicable connector

Type	Part number	Applicable lead wire
Connector housing	1-1827579-1 (TE Connectivity)	AWG28 (0.08 mm <sup>2</sup> ) AWG26 (0.12 mm <sup>2</sup> ) AWG24 (0.2 mm <sup>2</sup> ) AWG22 (0.37 mm <sup>2</sup> ) Lead wire insulation outer diameter: ø1.08 to 1.9 mm (ø0.043 to 0.075 in.) Lead wire insulation strip length: 1.7 to 2.3 mm (0.067 to 0.091 in.)
Contact	1827588-2 (TE Connectivity)	
Designated crimp tool	2119143-1 (TE Connectivity)	

### ■ Pin assignment

The figure shows the view from the insertion side of contacts.

Pin No.	Signal name	Description
A1	SG1	Ground 1 for RS-485 communication
A2	SG2	Ground 2 for RS-485 communication
B1	TR1-	Negative side of signal 1 for RS-485 communication
B2	TR2-	Negative side of signal 2 for RS-485 communication
C1	TR1+	Positive side of signal 1 for RS-485 communication
C2	TR2+	Positive side of signal 2 for RS-485 communication

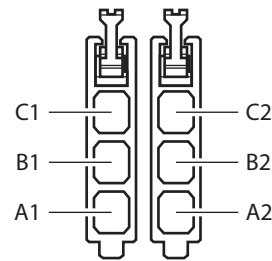

SG1 and SG2, TR1- and TR2-, and TR1+ and TR2+ are internally connected.

### Internal input circuit

GND of the power supply connector and SG of the RS-485 communication connector are electrically insulated. SW3 is a double-pole double-throw switch.

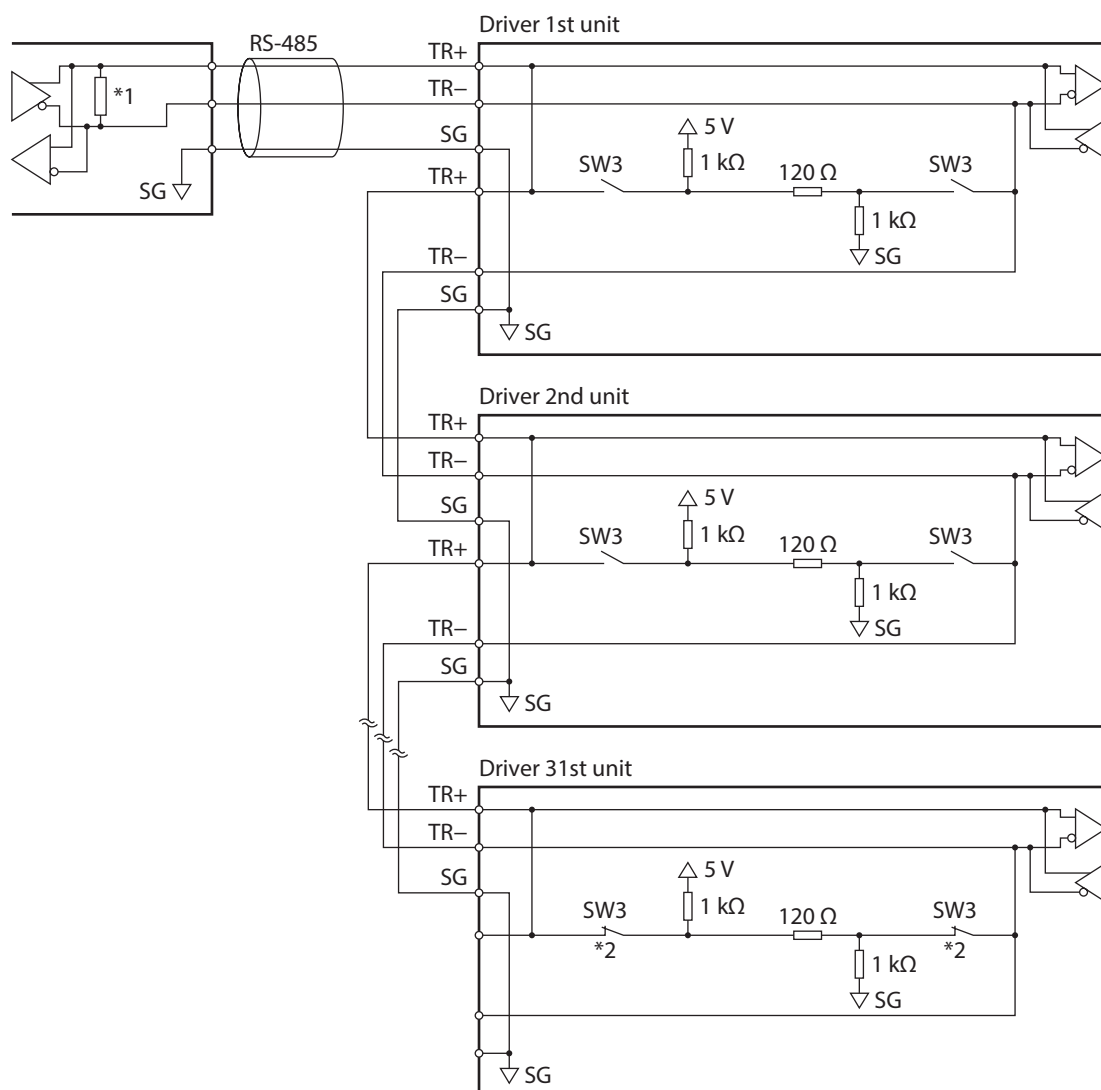

\*1 Termination resistor 120 Ω

\*2 Turn the termination resistor ON.

## 6-4 Connecting the USB cable

Using a USB cable with the following specifications, connect a PC in which the **MEXE02** has been installed to the USB connector.

Specifications	USB2.0 (Full speed)
Cable	Length: 3 m (9.8 ft.) or less Shape: A to mini B



- Connect the driver and a PC directly using a USB cable.
- In large electrically noisy environments, use the USB cable with a ferrite core or install a ferrite core to the USB cable.

## 6-5 Noise elimination measures

There are two types of electrical noise: One is noise that enters the driver from the outside and causes it to malfunction, and the other is noise that is emitted from the driver and causes peripheral equipment to malfunction. For noise entering the driver from the outside, take measures to prevent the driver from malfunctioning. It is necessary to take appropriate measures because the signal lines are very likely to be affected by the noise. For the noise that is emitted by the driver, take measures to suppress it.

### ■ Measures against electrical noise

- Install the driver inside a metal enclosure.
- Use a DC power supply that complies with the EMC Directive/Regulations for the power supply.
- When relays or electromagnetic switches are used, use noise filters or CR circuits to suppress the surge generated by these devices.
- Keep the cables as short as possible.
- Use shielded twisted pair cables for power lines and signal lines.
- Keep power lines, such as motor and power supply cables, at least 200 mm (7.87 in.) away from signal lines. Also do not bundle the cables or wire them in parallel. If the power cables and signal cables have to cross, cross them at right angle.
- Wrap the cable around a ferrite core. This will prevent the propagated noise from entering into the driver or from being emitted from the driver. To increase the effect of noise attenuation by the ferrite core, wrap the cable several more turns.
- To ground a shielded cable, use a conductive cable clamp that ensures contact with the entire circumference of the shielded cable, and ground it as close to the equipment as possible.
- Use a grounding wire that is as thick and short as possible for the connection.
- Choose a large and uniformly conductive surface for the grounding point.
- Ground the motor, driver and other peripheral control equipment so that a potential difference does not occur among the grounds.

## 6-6 Compliance with the EMC Directive/Regulations

Oriental Motor products are compliant with the EMC Directive/Regulations in accordance with "Example of installation and wiring" on p.21, under the terms of "6-5 Noise elimination measures" on p.20. The results of EMC testing of the equipment will vary depending on the type, layout, wiring method, etc. of the parts and components used. Verify compliance with the EMC Directive/Regulations in a condition where all parts and components, including Oriental Motor products, are assembled into the equipment.

### CAUTION

This equipment is not intended for use in residential environments nor for use on a low-voltage public network supplied in residential premises, and it may not provide adequate protection to radio reception interference in such environments.

● **Example of installation and wiring**

The figure shows an example when the cable type electromagnetic brake motor is used.

When connecting the following products, cover the motor cable with a shielded braided sleeving. Furthermore, EMC tests are performed with a shielded braided sleeving grounded at both ends with cable clamps.

- **AZ Series: AZM14, AZM15, AZM24, AZM26**
- **EAC Series: EACM2**
- **EAS Series: EASM2**
- **DR Series: DR20, DR28**
- **DGII Series: DGM60, DGR60**
- **EH Series: EH3, EH4**

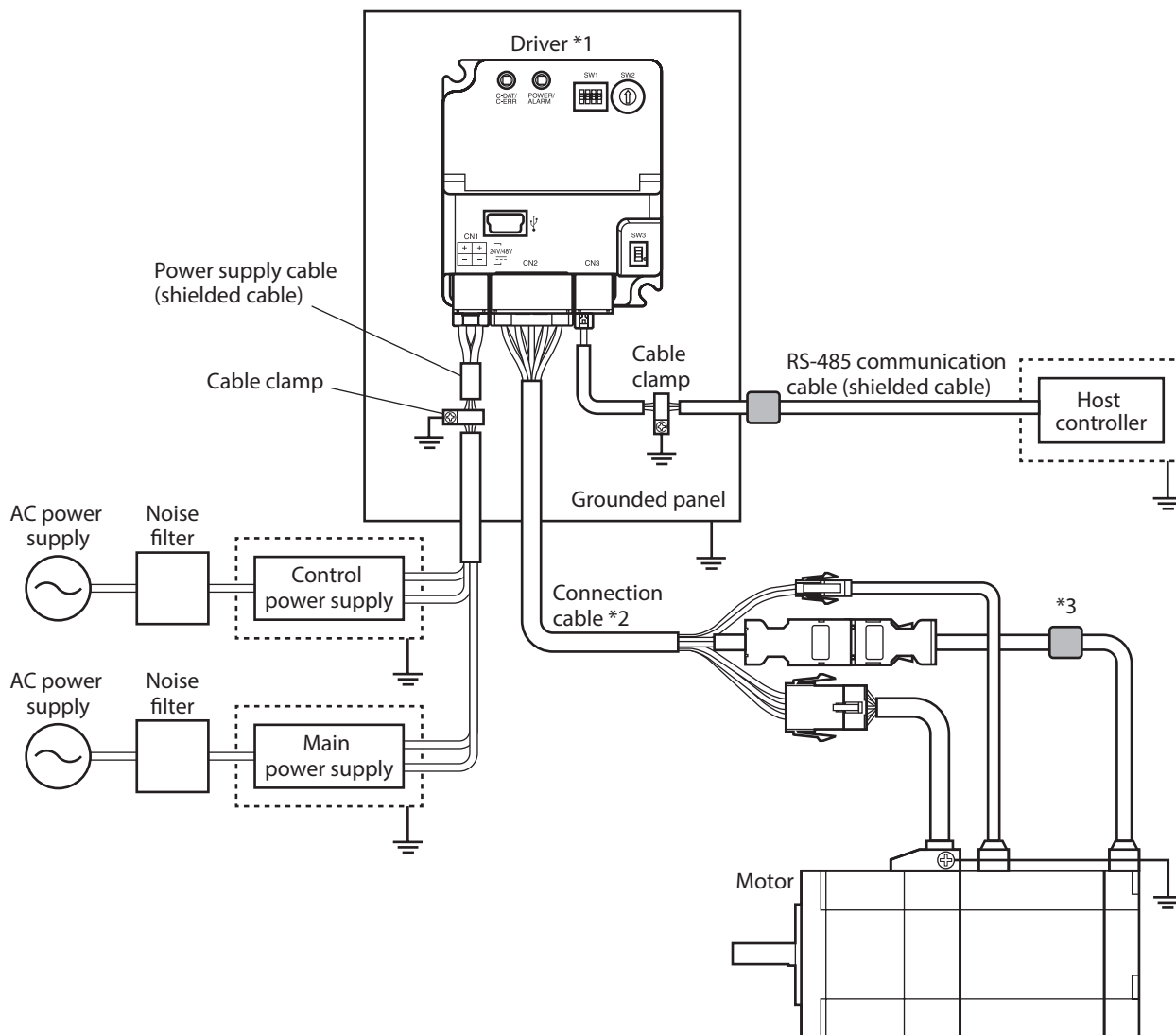

- is a shielding box.
- is a ferrite core.  
Model: ZCAT3035-1330 (TDK Corporation)
- ⏏ symbol indicate the grounding.

\*1 The driver is grounded by making the heat sink contact directly with the grounded panel.

\*2 An Oriental Motor cable is used.

\*3 For the **AZ** Series connector type motor, the EMC test is conducted in a state where a ferrite core is installed near the connector on the motor side of the connection cable.

# 7 Setting of switches

The figure shows the factory settings.

**Note** When setting the switch, turn on the main power supply and the control power supply again. The new setting is enabled when the main power supply and the control power supply are turned on again.

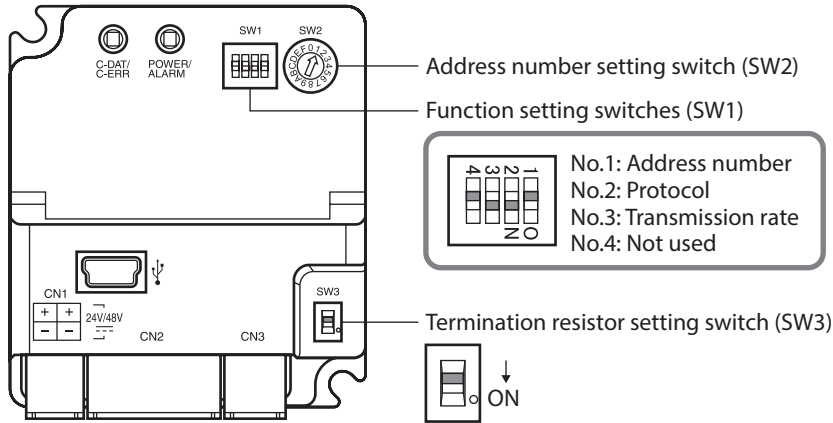

## 7-1 Protocol

Set the protocol of RS-485 communication using the function setting switch SW1-No.2.

**Factory setting ON**

SW1-No.2	Protocol
ON	Modbus RTU protocol
OFF	Connects to a network converter

## 7-2 Transmission rate

The transmission rate is set using the function setting switch SW1-No.3.  
Set the same value as the transmission rate of the host controller.

**Factory setting ON**

### ■ When using the driver with Modbus RTU (RS-485 communication)

SW1-No.3	Transmission rate (bps)
ON	230,400
OFF	115,200

**memo** To set a value other than the values in the table, set with the "Baudrate (Modbus)" parameter.

### ■ When using the driver via industrial network

Setting the transmission rate is not required.

## 7-3 Address number (server address)

Set the address number (server address) by concurrently using the address number setting switch SW2 and the function setting switch SW1-No.1. Make sure that each address number (server address) set for each driver is not duplicated.

**Factory settings** SW2: 1, SW1-No.1: OFF (address number 1)



The number of drivers that can be connected is different between Modbus RTU (RS-485 communication) and industrial network.

### ■ When using the driver with Modbus RTU (RS-485 communication)

The number of drivers that can be connected is 31 units maximum.

SW2	SW1-No.1	Address number (server address)	SW2	SW1-No.1	Address number (server address)
0	OFF	0 *	0	ON	16
1		1	1		17
2		2	2		18
3		3	3		19
4		4	4		20
5		5	5		21
6		6	6		22
7		7	7		23
8		8	8		24
9		9	9		25
A		10	A		26
B		11	B		27
C		12	C		28
D		13	D		29
E		14	E		30
F		15	F		31

\* In the case of Modbus protocol, do not use the address number 0 (server address 0) because it is reserved in the broadcast mode.

### ■ When using the driver via industrial network

The number of drivers that can be connected is 16 units maximum.

SW2	SW1-No.1	Address number (server address)
0	OFF	0
1		1
2		2
3		3
4		4
5		5
6		6
7		7
8		8
9		9
A		10
B		11
C		12
D		13
E		14
F		15

## 7-4 Termination resistor

Set a termination resistor to the driver located farthest (positioned at the end) from the host controller or the network converter.

Set the termination resistor setting switch (SW3) to ON to enable the termination resistor for RS-485 communication (120 Ω).

**Factory setting OFF**

SW3	Termination resistor (120 Ω)
OFF	Disable
ON	Enable

In the case of the following system configuration, setting the termination resistor is required for two drivers.

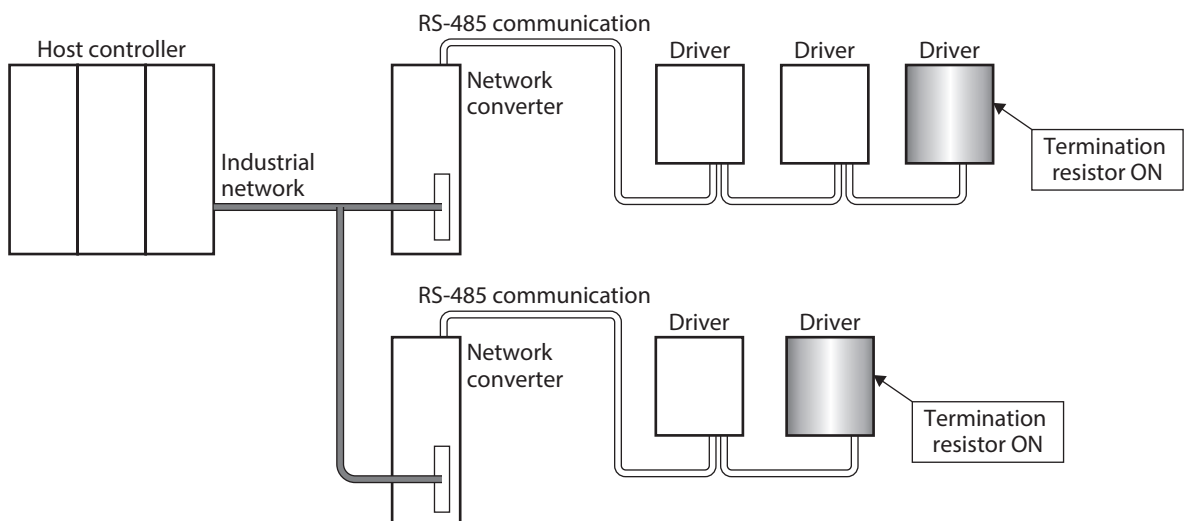

# 8 ID share mode

This chapter describes the ID share mode of Modbus RTU specific to the mini Driver.

When controlling the driver with other methods than the ID share mode, refer to the **AZ Series OPERATING MANUAL Function Edition** and “9 Addresses and codes lists” on p.45.

## 8-1 Overview of ID share mode

The ID share mode is Oriental Motor’s unique transmission mode in which multiple servers share a communication ID. The client sends a query to multiple servers. Each server executes the processing and returns a response. To read/write in the ID share mode, it is required to set a group of servers (share group) that operates in the ID share mode.

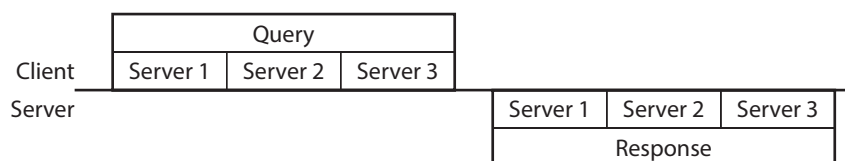

Even if a share group is set, communication can be performed in the unicast mode or the broadcast mode.

### ■ Features of ID share mode

- The client sends a query to multiple servers at once. Synchronization between servers is superior compared to the unicast mode.
- From the client, different information can separately be read/written from/to each server that shares the communication ID. Unlike the broadcast mode, different information can be written to multiple servers at one time.
- When a query is sent from the client, each server executes the processing and returns a response. Unlike the group send, a response is returned from all servers.

### ■ Overview of read

When reading data in the ID share mode, an ID of data to be read is required to set in the “Share read data” parameter. Setting the ID of data to be read in the “Share read data” parameter can read a value using the “Share read data” area of the ID share register address (\*).

\* It is the address dedicated to the ID share mode.

#### Setting an ID of data to be read

Register address	Name (parameter)
Upper: 0990h (2448) Lower: 0991h (2449)	Share read data 0
Upper: 0992h (2450) Lower: 0993h (2451)	Share read data 1
Upper: 0994h (2452) Lower: 0995h (2453)	Share read data 2

Setting with unicast mode or **MEXE02**

ID	Data to be read
0040h (64)	Present alarm
007Ch (124)	Driver temperature
007Dh (125)	Motor temperature

#### Reading a value

ID share register address	Name (area)
Upper: 0000h (0) Lower: 0001h (1)	Share read data 0
Upper: 0002h (2) Lower: 0003h (3)	Share read data 1
Upper: 0004h (4) Lower: 0005h (5)	Share read data 2

Read with ID share mode

Value	Data to be read
0	Present alarm
383	Driver temperature
426	Motor temperature

### ■ Overview of write

When writing data in the ID share mode, an ID of data to be written is required to set in the “Share write data” parameter. Setting the ID of data to be written in the “Share write data” parameter can write a value using the “Share write data” area of the ID share register address (\*).

\* It is the address dedicated to the ID share mode.

#### Setting an ID of data to be written

Register address	Name (parameter)
Upper: 09A8h (2472) Lower: 09A9h (2473)	Share write data 0
Upper: 09AAh (2474) Lower: 09ABh (2475)	Share write data 1
Upper: 09ACh (2476) Lower: 09ADh (2477)	Share write data 2

←  
Setting with unicast mode or **MEXE02**

ID	Data to be written
002Fh (47)	Direct data operation operating speed
0030h (48)	Direct data operation starting/changing rate
0031h (49)	Direct data operation stopping deceleration

#### Writing a value

ID share register address	Name (area)
Upper: 0000h (0) Lower: 0001h (1)	Share write data 0
Upper: 0002h (2) Lower: 0003h (3)	Share write data 1
Upper: 0004h (4) Lower: 0005h (5)	Share write data 2

←  
Write with ID share mode

Value	Data to be written
1,000	Direct data operation operating speed
1,000	Direct data operation starting/changing rate
2,000	Direct data operation stopping deceleration

### ■ Example of operation

This section explains the operation when the share group is set as shown in the figure and the command of positioning operation is sent from the client.

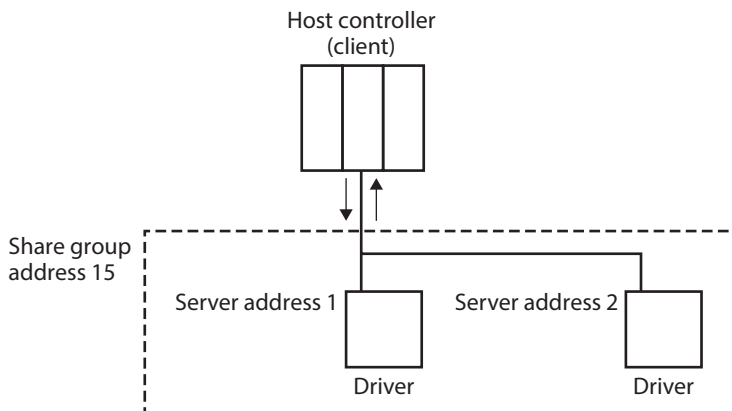

When a query is sent from the client to the share group address 15, the server addresses 1 and 2 start positioning operation. When each server executes the processing, a response is returned sequentially. The order in which responses are returned is set in the "Share control local ID" parameter. (⇒p.28)

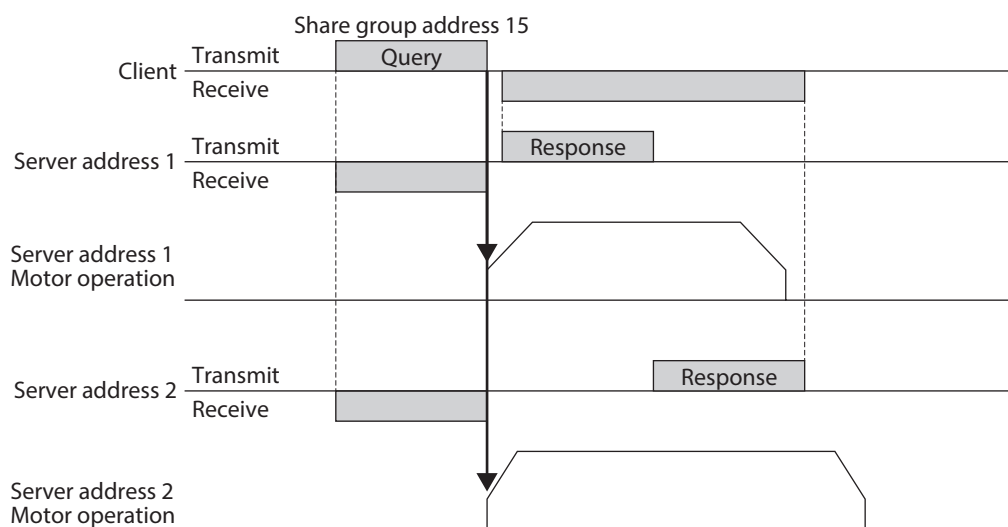

### ■ Corresponding function code

Function codes and message lengths supported by the ID share mode are shown below.

Function code	Function	Number of registers
03h	Reading from holding registers	1 to 24
10h	Writing to multiple holding registers	1 to 24
17h	Read/write of multiple holding registers	Read: 1 to 24 Write: 1 to 24

## 8-2 Flow of setting of ID share mode

To read/write data in the ID share mode, setting the share group and the data to be read/written is required.

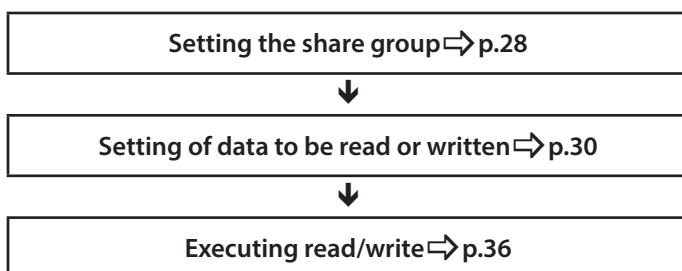

## 8-3 Setting of share group

Set a group (share group) that operates in the ID share mode to the driver. The share group can be set with the unicast mode or the **MEXE02**.

### ■ Related parameters

Recalculation and setup are immediately executed when the parameter is written.

MEXE02 code	Register address		Name	Description	Setting range	Initial value
	Upper	Lower				
p11	0980h (2432)	0981h (2433)	Share control global ID	Sets the communication ID shared in the ID share mode. The communication ID set here will be the share group address. Do not set "0" or the same value as the server address of the driver. The driver does not recognize the ID share mode, and it reads or writes a value different from the set data.	-1 (ID share mode is not used), 1 to 127 (Communication ID to share)	-1
	0982h (2434)	0983h (2435)	Share control number	Sets the number of server axes sharing the communication ID.	1 to 31	1
	0984h (2436)	0985h (2437)	Share control local ID	Sets an ID for identifying a server. Data is read/written in the order of ID set here. Set a number of ID consecutively starting from "1."	0 (ID share mode is not used), 1 to 31 (Server identification ID)	0

### ■ Setting example

This section explains how to set a share group in the figure.

To set a share group, use "Writing to multiple holding registers (10h)" of the function code.

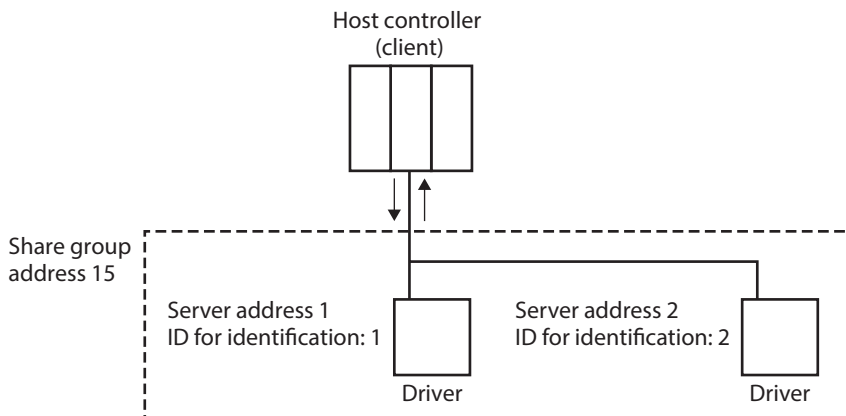

### ● Setting item

Description	Register address	Server address 1		Server address 2	
		Value write	Corresponding decimal	Value write	Corresponding decimal
Share control global ID (upper)	0980h (2432)	0000h	15	0000h	15
Share control global ID (lower)	0981h (2433)	000Fh		000Fh	
Share control number (upper)	0982h (2434)	0000h	2	0000h	2
Share control number (lower)	0983h (2435)	0002h		0002h	
Share control local ID (upper)	0984h (2436)	0000h	1	0000h	2
Share control local ID (lower)	0985h (2437)	0001h		0002h	

## ● Setting flow

1. Send the following query in the unicast mode to set a share group to the driver of the server address 1.

### Query (unicast mode)

Field name		Data	Description	
Server address		01h	Driver of server address 1	
Function code		10h	Writing to multiple holding registers	
Data	Register address (upper)	09h	Register address to start writing from = Share control global ID (upper): 0980h	
	Register address (lower)	80h		
	Number of registers (upper)	00h	Number of registers to be written from the starting register address = 6 registers (0006h)	
	Number of registers (lower)	06h		
	Number of data bytes		0Ch	Twice the number of registers in the query = 12
	Value write to register address (upper)		00h	Value written to register address 0980h = Share control global ID (upper): 0000h
	Value write to register address (lower)		00h	
	Value write to register address +1 (upper)		00h	Value written to register address 0981h = Share control global ID (lower): 000Fh
	Value write to register address +1 (lower)		0Fh	
	Value write to register address +2 (upper)		00h	Value written to register address 0982h = Share control number (upper): 0000h
	Value write to register address +2 (lower)		00h	
	Value write to register address +3 (upper)		00h	Value written to register address 0983h = Share control number (lower): 0002h
	Value write to register address +3 (lower)		02h	
	Value write to register address +4 (upper)		00h	Value written to register address 0984h = Share control local ID (upper): 0000h
	Value write to register address +4 (lower)		00h	
Value write to register address +5 (upper)		00h	Value written to register address 0985h = Share control local ID (lower): 0001h	
Value write to register address +5 (lower)		01h		
Error check (lower)		44h	Calculation result of CRC-16	
Error check (upper)		D5h		

### Response (unicast mode)

Field name		Data	Description
Server address		01h	Same as query
Function code		10h	Same as query
Data	Register address (upper)	09h	Same as query
	Register address (lower)	80h	
	Number of registers (upper)	00h	Same as query
	Number of registers (lower)	06h	
Error check (lower)		42h	Calculation result of CRC-16
Error check (upper)		7Fh	

2. Set a share group to the driver of the server address 2 as in the step 1.



Parameters having set in the unicast mode are cleared when the main power supply and the control power supply are turned off because they are stored in RAM. If the "Write batch NV memory" of the maintenance command is executed, parameters are saved in the non-volatile memory. Therefore, they are retained even if the main power supply and the control power supply are turned off.

## 8-4 Setting of data to be read or written

Set the data to be read in the “Share read data” parameter and the data to be written in the “Share write data” parameter.  
 Data can be set with the unicast mode or the **MEXE02**.

### ■ Related parameters

Recalculation and setup are immediately executed when the parameter is written.

MEXE02 code	Register address		Name	Description	Setting range	Initial value
	Upper	Lower				
p11	0990h (2448)	0991h (2449)	Share read data 0	Sets the ID of data to be read in the ID share mode.	ID list → p.31	0
	0992h (2450)	0993h (2451)	Share read data 1			
	0994h (2452)	0995h (2453)	Share read data 2			
	0996h (2454)	0997h (2455)	Share read data 3			
	0998h (2456)	0999h (2457)	Share read data 4			
	099Ah (2458)	099Bh (2459)	Share read data 5			
	099Ch (2460)	099Dh (2461)	Share read data 6			
	099Eh (2462)	099Fh (2463)	Share read data 7			
	09A0h (2464)	09A1h (2465)	Share read data 8			
	09A2h (2466)	09A3h (2467)	Share read data 9			
	09A4h (2468)	09A5h (2469)	Share read data 10			
	09A6h (2470)	09A7h (2471)	Share read data 11	Sets the ID of data to be written in the ID share mode.	ID list → p.31	0
	09A8h (2472)	09A9h (2473)	Share write data 0			
	09AAh (2474)	09ABh (2475)	Share write data 1			
	09ACh (2476)	09ADh (2477)	Share write data 2			
	09AEh (2478)	09AFh (2479)	Share write data 3			
	09B0h (2480)	09B1h (2481)	Share write data 4			
	09B2h (2482)	09B3h (2483)	Share write data 5			
	09B4h (2484)	09B5h (2485)	Share write data 6			
	09B6h (2486)	09B7h (2487)	Share write data 7			
09B8h (2488)	09B9h (2489)	Share write data 8				
09BAh (2490)	09BBh (2491)	Share write data 9				

MEXE02 code	Register address		Name	Description	Setting range	Initial value
	Upper	Lower				
p11	09BCh (2492)	09BDh (2493)	Share write data 10	Sets the ID of data to be written in the ID share mode.	ID list ⇒ Refer to the next table.	0
	09BEh (2494)	09BFh (2495)	Share write data 11			

● **Data that can be set in the “Share read data” parameter and the “Share write data” parameter**

This section shows data that can be read or written in the ID share mode. Use “ID” in the table when setting the data. “R/W” in the table represents “READ/WRITE.”

ID		Name	Description	R/W
Hex	Dec			
002Ch	44	Direct data operation operation data number	Selects the operation data number used for direct data operation. [Setting range] 0 to 255	R/W
002Dh	45	Direct data operation operation type	Sets the operation type for direct data operation. [Setting range] 0: No setting 1: Absolute positioning 2: Incremental positioning (based on command position) 3: Incremental positioning (based on feedback position) 7: Continuous operation (position control) 8: Wrap absolute positioning 9: Wrap proximity positioning 10: Wrap absolute positioning (FWD) 11: Wrap absolute positioning (RVS) 12: Wrap absolute push-motion 13: Wrap proximity push-motion 14: Wrap push-motion (FWD) 15: Wrap push-motion (RVS) 16: Continuous operation (speed control) 17: Continuous operation (push-motion) 18: Continuous operation (torque control) 20: Absolute positioning push-motion 21: Incremental positioning push-motion (based on command position) 22: Incremental positioning push-motion (based on feedback position)	R/W
002Eh	46	Direct data operation position	Sets the target position for direct data operation. [Setting range] –2,147,483,648 to 2,147,483,647 steps	R/W
002Fh	47	Direct data operation operating speed	Sets the operating speed for direct data operation. [Setting range] –4,000,000 to 4,000,000 Hz	R/W
0030h	48	Direct data operation starting/changing rate	Sets the acceleration/deceleration rate or the acceleration/ deceleration time for direct data operation. [Setting range] 1 to 1,000,000,000 (1=0.001 kHz/s, 1=0.001 s, or 1=0.001 ms/kHz)	R/W
0031h	49	Direct data operation stopping deceleration	Sets the stopping deceleration rate or the stop time for direct data operation. [Setting range] 1 to 1,000,000,000 (1=0.001 kHz/s, 1=0.001 s, or 1=0.001 ms/kHz)	R/W
0032h	50	Direct data operation operating current	Sets the operating current for direct data operation. [Setting range] 0 to 1,000 (1=0.1 %)	R/W

ID		Name	Description	R/W
Hex	Dec			
0033h	51	Direct data operation trigger	Sets the trigger for direct data operation. [Setting range] –7: Operation data number –6: Operation type –5: Position –4: Operating speed –3: Starting/changing speed rate –2: Stopping deceleration –1: Operating current 0: Disable 1: All data updated	R/W
0034h	52	Direct data operation forwarding destination	Selects the stored area when the next direct data is transferred during direct data operation. [Setting range] 0: Execution memory 1: Buffer memory	R/W
003Ah	58	Driver input command (2nd)	The same input command as “Driver input command (reference)” is automatically set.	W
003Ch	60	Driver input command (automatic OFF)	The same input command as “Driver input command (reference)” is automatically set. If the input signal is turned ON with this command, it is automatically turned OFF after 250 $\mu$ s.	W
003Eh	62	Driver input command (reference)	Sets the input command to the driver.	W
003Fh	63	Driver output status	Reads the output status of the driver.	R
0040h	64	Present alarm	Indicates the alarm code presently being generated.	R
0056h	86	Present communication error	Indicates the communication error code received last time.	R
0063h	99	Command position	Indicates the present command position. When the wrap function is enabled, the value on the wrap coordinates is indicated.	R
0064h	100	Command speed (r/min)	Indicates the present command speed. (r/min)	R
0065h	101	Command speed (Hz)	Indicates the present command speed. (Hz)	R
0066h	102	Feedback position	Indicates the present feedback position.	R
0067h	103	Feedback speed (r/min)	Indicates the present feedback speed. (r/min)	R
0068h	104	Feedback speed (Hz)	Indicates the present feedback speed. (Hz)	R
006Ah	106	Direct I/O	Indicates the status of direct I/O. (Arrangement of bits $\Rightarrow$ p.46)	R
006Bh	107	Torque monitor	Indicates the torque presently generated as a percentage of the maximum holding torque.	R
006Dh	109	Cumulative load monitor	Indicates the integrated value of the load during operation. (Internal unit) The load is cumulated regardless of the rotation direction of the motor. Refer to the <b>AZ</b> Series <u>OPERATING MANUAL Function Edition</u> for details about the cumulative load monitor.	R
007Ch	124	Driver temperature	Indicates the present driver temperature. (1=0.1 $^{\circ}$ C)	R
007Dh	125	Motor temperature	Indicates the present motor temperature. (1=0.1 $^{\circ}$ C)	R
007Eh	126	Odometer	Indicates the cumulative travel distance of the motor in revolutions. (1=0.1 krev) This cannot be cleared by the customer.	R
007Fh	127	Tripmeter	Indicates the travel distance of the motor in revolutions. (1=0.1 krev) This can be cleared by the customer.	R

ID		Name	Description	R/W
Hex	Dec			
00A1h	161	Main power supply time	Indicates the time elapsed since the main power supply was turned on in minutes.	R
00A2h	162	Control power supply count	Indicates the number of times the control power supply was turned on.	R
00A3h	163	Inverter voltage	Indicates the inverter voltage of the driver. (1=0.1 V)	R
00A4h	164	Main power supply voltage	Indicates the main power supply voltage. (1=0.1 V)	R
00A9h	169	Elapsed time from BOOT	Indicates the time elapsed since the control power supply was turned on. For a driver that the control power supply is not connected, it indicates the time elapsed since the main power supply was turned on.	R
00ACh	172	RS-485 communication normal reception frame counter (All)	Indicates the number of normal frames received.	R
00ADh	173	RS-485 communication normal reception frame counter (Only own address)	Indicates the number of normal frames received to own address.	R
00B8h	184	I/O status 1	Indicates the ON-OFF status of the internal I/O. (Arrangement of bits ⇨ p.46)	R
00B9h	185	I/O status 2		R
00BAh	186	I/O status 3		R
00BBh	187	I/O status 4		R
00BCh	188	I/O status 5		R
00BDh	189	I/O status 6		R
00BEh	190	I/O status 7		R
00BFh	191	I/O status 8		R
00C0h	192	Alarm reset	Resets the alarm being generated presently. Some alarms cannot be reset.	W
00D3h	211	Clear information	Clears the information.	W

## ■ Setting example of data to be read

To set data, use "Writing to multiple holding registers (10h)" of the function code.

This section explains an example that "Present alarm," "Driver temperature," and "Motor temperature" are set in the "Share read data" parameter of the server addresses 1 and 2.

### ● Setting item

Description	Register address	Data to be read	ID	
			Hex	Dec
Share read data 0 (upper)	0990h (2448)	Present alarm	0000h	64
Share read data 0 (lower)	0991h (2449)		0040h	
Share read data 1 (upper)	0992h (2450)	Driver temperature	0000h	124
Share read data 1 (lower)	0993h (2451)		007Ch	
Share read data 2 (upper)	0994h (2452)	Motor temperature	0000h	125
Share read data 2 (lower)	0995h (2453)		007Dh	



Different data can be set for each server address.

- Setting example

Server address 1: Present alarm, Driver temperature, Motor temperature

Server address 2: Odometer, Tripmeter, Main power supply time

- **Setting flow**

1. Send the following query in the unicast mode, and set the data to be read to the driver of the server address 1.

**Query (unicast mode)**

Field name		Data	Description	
Server address		01h	Driver of server address 1	
Function code		10h	Writing to multiple holding registers	
Data	Register address (upper)	09h	Register address to start writing from = Share read data 0 (upper): 0990h	
	Register address (lower)	90h		
	Number of registers (upper)	00h	Number of registers to be written from the starting register address = 6 registers (0006h)	
	Number of registers (lower)	06h		
	Number of data bytes		0Ch	Twice the number of registers in the query
	Value write to register address (upper)		00h	Value written to register addresses 0990h and 0991h = Present alarm ID (0000h, 0040h)
	Value write to register address (lower)		00h	
	Value write to register address +1 (upper)		00h	
	Value write to register address +1 (lower)		40h	
	Value write to register address +2 (upper)		00h	Value written to register addresses 0992h and 0993h = Driver temperature ID (0000h, 007Ch)
	Value write to register address +2 (lower)		00h	
	Value write to register address +3 (upper)		00h	
	Value write to register address +3 (lower)		7Ch	
	Value write to register address +4 (upper)		00h	Value written to register addresses 0994h and 0995h = Motor temperature ID (0000h, 007Dh)
	Value write to register address +4 (lower)		00h	
	Value write to register address +5 (upper)		00h	
Value write to register address +5 (lower)		7Dh		
Error check (lower)		10h	Calculation result of CRC-16	
Error check (upper)		C1h		

**Response (unicast mode)**

Field name		Data	Description
Server address		01h	Same as query
Function code		10h	Same as query
Data	Register address (upper)	09h	Same as query
	Register address (lower)	90h	
	Number of registers (upper)	00h	Same as query
	Number of registers (lower)	06h	
Error check (lower)		43h	Calculation result of CRC-16
Error check (upper)		BAh	

2. Set the data to be read to the driver of the server address 2 as in the step 1.



Parameters having set in the unicast mode are cleared when the main power supply and the control power supply are turned off because they are stored in RAM. If the "Write batch NV memory" of the maintenance command is executed, parameters are saved in the non-volatile memory. Therefore, they are retained even if the main power supply and the control power supply are turned off.

## ■ Setting example of data to be written

To set parameters, use "Writing to multiple holding registers (10h)" of the function code.

This section explains an example that "Direct data operation operating speed," "Direct data operation starting/ changing rate," and "Direct data operation stopping deceleration" are set in the "Share write data" parameter of the server addresses 1 and 2.

### ● Setting item

Description	Register address	Data to be written	ID	
			Hex	Dec
Share write data 0 (upper)	09A8h (2472)	Direct data operation operating speed	0000h	47
Share write data 0 (lower)	09A9h (2473)		002Fh	
Share write data 1 (upper)	09AAh (2474)	Direct data operation starting/ changing rate	0000h	48
Share write data 1 (lower)	09ABh (2475)		0030h	
Share write data 2 (upper)	09ACh (2476)	Direct data operation stopping deceleration	0000h	49
Share write data 2 (lower)	09ADh (2477)		0031h	



Different data can be set for each server address.

- Setting example

Server address 1: Direct data operation operating speed, Direct data operation starting/ changing rate, Direct data operation stopping deceleration

Server address 2: Direct data operation operation data number, Direct data operation operation type, Direct data operation operating current

### ● Setting flow

1. Send the following query in the unicast mode, and set the data to be written to the driver of the server address 1.

#### Query (unicast mode)

Field name	Data	Description	
Server address	01h	Driver of server address 1	
Function code	10h	Writing to multiple holding registers	
Data	Register address (upper)	09h	
	Register address (lower)	A8h	Register address to start writing from = Share write data 0 (upper): 09A8h
	Number of registers (upper)	00h	Number of registers to be written from the starting register address = 6 registers (0006h)
	Number of registers (lower)	06h	
	Number of data bytes	0Ch	Twice the number of registers in the query
	Value write to register address (upper)	00h	Value written to register addresses 09A8h and 09A9h = Direct data operation operating speed ID (0000h, 002Fh)
	Value write to register address (lower)	00h	
	Value write to register address +1 (upper)	00h	
	Value write to register address +1 (lower)	2Fh	
	Value write to register address +2 (upper)	00h	Value written to register addresses 09AAh and 09ABh = Direct data operation starting/ changing rate ID (0000h, 0030h)
	Value write to register address +2 (lower)	00h	
	Value write to register address +3 (upper)	00h	
	Value write to register address +3 (lower)	30h	
	Value write to register address +4 (upper)	00h	Value written to register addresses 09ACh and 09ADh = Direct data operation stopping deceleration ID (0000h, 0031h)
Value write to register address +4 (lower)	00h		
Value write to register address +5 (upper)	00h		
Value write to register address +5 (lower)	31h		
Error check (lower)	FAh	Calculation result of CRC-16	
Error check (upper)	DAh		

**Response (unicast mode)**

Field name		Data	Description
Server address		01h	Same as query
Function code		10h	Same as query
Data	Register address (upper)	09h	Same as query
	Register address (lower)	A8h	
	Number of registers (upper)	00h	Same as query
	Number of registers (lower)	06h	
Error check (lower)		C2h	Calculation result of CRC-16
Error check (upper)		77h	

2. Set the data to be written to the driver of the server address 2 as in the step 1.



Parameters having set in the unicast mode are cleared when the main power supply and the control power supply are turned off because they are stored in RAM. If the "Write batch NV memory" of the maintenance command is executed, parameters are saved in the non-volatile memory. Therefore, they are retained even if the main power supply and the control power supply are turned off.

## 8-5 Executing read/write

Read and write data in the ID share mode.

The following function codes are used for reading and writing data.

- Read only: Reading from a holding register(s) (03h)
- Write only: Writing to multiple holding registers (10h)
- Read/write: Read/write of multiple holding registers (17h)

When "Read/write of multiple holding registers (17h)" of the function code is used, write is executed first, and then read is executed. Queries are sent in the order of read and write. The order to send cannot be changed.

### ■ Read

Read the value (16 bits) using the "Share read data" area of the ID share register address. Up to 24 successive registers (24 × 16 bits) can be read.

Read the upper and lower values at the same time. If not, an invalid value may be read.

If multiple holding registers are read, they are executed in the order of ID share register addresses.

#### ID share register address of "Share read data" area

ID share register address		Name
Upper	Lower	
0000h (0)	0001h (1)	Share read data 0
0002h (2)	0003h (3)	Share read data 1
0004h (4)	0005h (5)	Share read data 2
0006h (6)	0007h (7)	Share read data 3
0008h (8)	0009h (9)	Share read data 4
000Ah (10)	000Bh (11)	Share read data 5

ID share register address		Name
Upper	Lower	
000Ch (12)	000Dh (13)	Share read data 6
000Eh (14)	000Fh (15)	Share read data 7
0010h (16)	0011h (17)	Share read data 8
0012h (18)	0013h (19)	Share read data 9
0014h (20)	0015h (21)	Share read data 10
0016h (22)	0017h (23)	Share read data 11

## ■ Write

Write the value (16 bits) using the “Share write data” area of the ID share register address. Up to 24 registers (24 × 16 bits) can be written.

Write the upper and lower values at the same time. If not, an invalid value may be written.

Write is executed in the order of ID share register addresses. Note that even when an exception response is returned because some data is invalid as being outside the specified range, etc., other data may have been written properly.

### ID share register address of “Share write data” area

ID share register address		Name
Upper	Lower	
0000h (0)	0001h (1)	Share write data 0
0002h (2)	0003h (3)	Share write data 1
0004h (4)	0005h (5)	Share write data 2
0006h (6)	0007h (7)	Share write data 3
0008h (8)	0009h (9)	Share write data 4
000Ah (10)	000Bh (11)	Share write data 5

ID share register address		Name
Upper	Lower	
000Ch (12)	000Dh (13)	Share write data 6
000Eh (14)	000Fh (15)	Share write data 7
0010h (16)	0011h (17)	Share write data 8
0012h (18)	0013h (19)	Share write data 9
0014h (20)	0015h (21)	Share write data 10
0016h (22)	0017h (23)	Share write data 11

## ■ Example of read

Read “Present alarm,” “Driver temperature” and “Motor temperature” from the server addresses 1 and 2.

Description	ID share register address	Server address 1		Server address 2	
		Value read	Corresponding decimal	Value read	Corresponding decimal
Present alarm (upper)	0000h (0): Share read data 0 (upper)	0000h	0	0000h	48
Present alarm (lower)	0001h (1): Share read data 0 (lower)	0000h		0030h	
Driver temperature (upper)	0002h (2): Share read data 1 (upper)	0000h	383	0000h	450
Driver temperature (lower)	0003h (3): Share read data 1 (lower)	017Fh		01C2h	
Motor temperature (upper)	0004h (4): Share read data 2 (upper)	0000h	426	0000h	538
Motor temperature (lower)	0005h (5): Share read data 2 (lower)	01AAh		021Ah	

### Query (ID share mode)

Field name		Data	Description
Server address		0Fh	Share group address 15
Function code		03h	Reading from holding registers
Data	ID share register address (upper)	00h	ID share register address to start reading from = Share read data 0 (upper): 0000h
	ID share register address (lower)	00h	
	Number of registers (upper)	00h	
	Number of registers (lower)	0Eh	
Error check (lower)		C5h	Calculation result of CRC-16
Error check (upper)		20h	

\* Number of registers = (number of ID share register addresses to be read + 1) × Share control number

- Number of register addresses to be read: 6 (0000h to 0005h)
- +1: Error check between servers
- Share control number: 2



Note that the number of registers in the ID share mode is calculated differently from that in other transmission modes of RS-485 communication.

## Response (ID share mode)

Field name		Data	Description	
Server address		0Fh	Same as query	
Function code		03h	Same as query	
Data	Number of data bytes	1Ch	Twice the number of registers in the query	
	*1	Value read from ID share register address (upper)	00h	Value read from ID share register address 0000h = Present alarm (upper): 0000h
		Value read from ID share register address (lower)	00h	
		Value read from ID share register address +1 (upper)	00h	Value read from ID share register address 0001h = Present alarm (lower): 0000h
		Value read from ID share register address +1 (lower)	00h	
		Value read from ID share register address +2 (upper)	00h	Value read from ID share register address 0002h = Driver temperature (upper): 0000h
		Value read from ID share register address +2 (lower)	00h	
		Value read from ID share register address +3 (upper)	01h	Value read from ID share register address 0003h = Driver temperature (lower): 017Fh
		Value read from ID share register address +3 (lower)	7Fh	
		Value read from ID share register address +4 (upper)	00h	Value read from ID share register address 0004h = Motor temperature (upper): 0000h
		Value read from ID share register address +4 (lower)	00h	
		Value read from ID share register address +5 (upper)	01h	Value read from ID share register address 0005h = Motor temperature (lower): 01AAh
		Value read from ID share register address +5 (lower)	AAh	
		Error check for between servers (lower) *3	B6h	Calculation result of CRC-16 (The value varies depending on the monitor value.)
Error check for between servers (upper) *3	10h			
Data	*2	Value read from ID share register address (upper)	00h	Value read from ID share register address 0000h = Present alarm (upper): 0000h
		Value read from ID share register address (lower)	00h	
		Value read from ID share register address +1 (upper)	00h	Value read from ID share register address 0001h = Present alarm (lower): 0030h
		Value read from ID share register address +1 (lower)	30h	
		Value read from ID share register address +2 (upper)	00h	Value read from ID share register address 0002h = Driver temperature (upper): 0000h
		Value read from ID share register address +2 (lower)	00h	
		Value read from ID share register address +3 (upper)	01h	Value read from ID share register address 0003h = Driver temperature (lower): 01C2h
		Value read from ID share register address +3 (lower)	C2h	
		Value read from ID share register address +4 (upper)	00h	Value read from ID share register address 0004h = Motor temperature (upper): 0000h
		Value read from ID share register address +4 (lower)	00h	
		Value read from ID share register address +5 (upper)	02h	Value read from ID share register address 0005h = Motor temperature (lower): 021Ah
		Value read from ID share register address +5 (lower)	1Ah	
		Error check for between servers (lower) *3	ACh	Calculation result of CRC-16 (The value varies depending on the monitor value.)
	Error check for between servers (upper) *3	AAh		
Error check (lower)	00h	Calculation result of CRC-16		
Error check (upper)	00h			

\*1 Server address 1 (Share control local ID: 1)

\*2 Server address 2 (Share control local ID: 2)

\*3 Each time data is sent to each server, an error check is performed on the data that has already been sent.

## ■ Example of write

Write "Direct data operation operating speed," "Direct data operation starting/changing rate," and "Direct data operation stopping deceleration" to the server addresses 1 and 2.

Description	ID share register address	Server address 1		Server address 2	
		Value write	Corresponding decimal	Value write	Corresponding decimal
Direct data operation operating speed (upper)	0000h (0): Share write data 0 (upper)	0000h	1,000	0000h	2,000
Direct data operation operating speed (lower)	0001h (1): Share write data 0 (lower)	03E8h		07D0h	
Direct data operation starting/changing rate (upper)	0002h (2): Share write data 1 (upper)	0000h	1,000	0000h	2,000
Direct data operation starting/changing rate (lower)	0003h (3): Share write data 1 (lower)	03E8h		07D0h	
Direct data operation stopping deceleration (upper)	0004h (4): Share write data 2 (upper)	0000h	2,000	0000h	5,000
Direct data operation stopping deceleration (lower)	0005h (5): Share write data 2 (lower)	07D0h		1388h	

### Query (ID share mode)

Field name		Data	Description	
Server address		0Fh	Share group address 15	
Function code		10h	Writing to multiple holding registers	
Data	ID share register address (upper)	00h	ID share register address to start writing from = Share write data 0 (upper): 0000h	
	ID share register address (lower)	00h		
	Number of registers (upper)	00h	Number of registers to be written from the starting ID share register address = 12 registers (000Ch) *1	
	Number of registers (lower)	0Ch		
	Number of data bytes		18h	Twice the number of registers in the query
	*2	Value write to ID share register address (upper)	00h	Value written to ID share register address 0000h = Direct data operation operating speed (upper): 0000h
		Value write to ID share register address (lower)	00h	
		Value write to ID share register address +1 (upper)	03h	Value written to ID share register address 0001h = Direct data operation operating speed (lower): 03E8h
		Value write to ID share register address +1 (lower)	E8h	
		Value write to ID share register address +2 (upper)	00h	Value written to ID share register address 0002h = Direct data operation starting/changing rate (upper): 0000h
		Value write to ID share register address +2 (lower)	00h	
		Value write to ID share register address +3 (upper)	03h	Value written to ID share register address 0003h = Direct data operation starting/changing rate (lower): 03E8h
		Value write to ID share register address +3 (lower)	E8h	
		Value write to ID share register address +4 (upper)	00h	Value written to ID share register address 0004h = Direct data operation stopping deceleration (upper): 0000h
Value write to ID share register address +4 (lower)		00h		
Value write to ID share register address +5 (upper)		07h	Value written to ID share register address 0005h = Direct data operation stopping deceleration (lower): 07D0h	
Value write to ID share register address +5 (lower)		D0h		

Field name		Data	Description	
Data	*3	Value write to ID share register address (upper)	00h	Value written to ID share register address 0000h = Direct data operation operating speed (upper): 0000h
		Value write to ID share register address (lower)	00h	
		Value write to ID share register address +1 (upper)	07h	Value written to ID share register address 0001h = Direct data operation operating speed (lower): 07D0h
		Value write to ID share register address +1 (lower)	D0h	
		Value write to ID share register address +2 (upper)	00h	Value written to ID share register address 0002h = Direct data operation starting/ changing rate (upper): 0000h
		Value write to ID share register address +2 (lower)	00h	
		Value write to ID share register address +3 (upper)	07h	Value written to ID share register address 0003h = Direct data operation starting/ changing rate (lower): 07D0h
		Value write to ID share register address +3 (lower)	D0h	
		Value write to ID share register address +4 (upper)	00h	Value written to ID share register address 0004h = Direct data operation stopping deceleration (upper): 0000h
		Value write to ID share register address +4 (lower)	00h	
		Value write to ID share register address +5 (upper)	13h	Value written to ID share register address 0005h = Direct data operation stopping deceleration (lower): 1388h
		Value write to ID share register address +5 (lower)	88h	
Error check (lower)		99h	Calculation result of CRC-16	
Error check (upper)		21h		

\*1 Number of registers = (Share control number) × Number of ID share register addresses to be written

- Share control number: 2
- Number of register addresses to be written: 6 (0000h to 0005h)

\*2 Server address 1 (Share control local ID: 1)

\*3 Server address 2 (Share control local ID: 2)



Note that the number of registers in the ID share mode is calculated differently from that in other transmission modes of RS-485 communication.

### Response (ID share mode)

Field name		Data	Description
Server address		0Fh	Same as query
Function code		10h	Same as query
Data	ID share register address (upper)	00h	Same as query
	ID share register address (lower)	00h	
	Number of registers (upper)	00h	Same as query
	Number of registers (lower)	0Ch	
Error check (lower)		C1h	Calculation result of CRC-16
Error check (upper)		22h	

## ■ Example of read/write

Write values to "Direct data operation operating speed," "Direct data operation starting/changing rate," and "Direct data operation stopping deceleration" first, and read "Present alarm," "Driver temperature," and "Motor temperature."

Description	ID share register address	Server address 1		Server address 2	
		Value write	Corresponding decimal	Value write	Corresponding decimal
Direct data operation operating speed (upper)	0000h (0): Share write data 0 (upper)	0000h	1,000	0000h	2,000
Direct data operation operating speed (lower)	0001h (1): Share write data 0 (lower)	03E8h		07D0h	
Direct data operation starting/changing rate (upper)	0002h (2): Share write data 1 (upper)	0000h	1,000	0000h	2,000
Direct data operation starting/changing rate (lower)	0003h (3): Share write data 1 (lower)	03E8h		07D0h	
Direct data operation stopping deceleration (upper)	0004h (4): Share write data 2 (upper)	0000h	2,000	0000h	5,000
Direct data operation stopping deceleration (lower)	0005h (5): Share write data 2 (lower)	07D0h		1388h	

Description	ID share register address	Server address 1		Server address 2	
		Value read	Corresponding decimal	Value read	Corresponding decimal
Present alarm (upper)	0000h (0): Share read data 0 (upper)	0000h	0	0000h	48
Present alarm (lower)	0001h (1): Share read data 0 (lower)	0000h		0030h	
Driver temperature (upper)	0002h (2): Share read data 1 (upper)	0000h	383	0000h	450
Driver temperature (lower)	0003h (3): Share read data 1 (lower)	017Fh		01C2h	
Motor temperature (upper)	0004h (4): Share read data 2 (upper)	0000h	426	0000h	538
Motor temperature (lower)	0005h (5): Share read data 2 (lower)	01AAh		021Ah	

### Query (ID share mode)

Field name		Data	Description
Server address		0Fh	Share group address 15
Function code		17h	Read/write of multiple holding registers
Data	(Read) ID share register address (upper)	00h	ID share register address to start reading from = Share read data 0 (upper): 0000h
	(Read) ID share register address (lower)	00h	
	(Read) Number of registers (upper)	00h	Number of registers to be read from the starting ID share register address = 14 registers (000Eh) *1
	(Read) Number of registers (lower)	0Eh	
	(Write) ID share register address (upper)	00h	ID share register address to start writing from = Share write data 0 (upper): 0000h
	(Write) ID share register address (lower)	00h	
	(Write) Number of registers (upper)	00h	Number of registers to be written from the starting ID share register address = 12 registers (000Ch) *2
	(Write) Number of registers (lower)	0Ch	
(Write) Number of data bytes		18h	Twice the number of registers in the query

Field name		Data	Description	
Data	*3	Value write to ID share register address (upper)	00h	Value written to ID share register address 0000h = Direct data operation operating speed (upper): 0000h
		Value write to ID share register address (lower)	00h	
		Value write to ID share register address +1 (upper)	03h	Value written to ID share register address 0001h = Direct data operation operating speed (lower): 03E8h
		Value write to ID share register address +1 (lower)	E8h	
		Value write to ID share register address +2 (upper)	00h	Value written to ID share register address 0002h = Direct data operation starting/ changing rate (upper): 0000h
		Value write to ID share register address +2 (lower)	00h	
		Value write to ID share register address +3 (upper)	03h	Value written to ID share register address 0003h = Direct data operation starting/ changing rate (lower): 03E8h
		Value write to ID share register address +3 (lower)	E8h	
		Value write to ID share register address +4 (upper)	00h	Value written to ID share register address 0004h = Direct data operation stopping deceleration (upper): 0000h
		Value write to ID share register address +4 (lower)	00h	
		Value write to ID share register address +5 (upper)	07h	Value written to ID share register address 0005h = Direct data operation stopping deceleration (lower): 07D0h
		Value write to ID share register address +5 (lower)	D0h	
	*4	Value write to ID share register address (upper)	00h	Value written to ID share register address 0000h = Direct data operation operating speed (upper): 0000h
			00h	
		Value write to ID share register address +1 (upper)	07h	Value written to ID share register address 0001h = Direct data operation operating speed (lower): 07D0h
			D0h	
		Value write to ID share register address +2 (upper)	00h	Value written to ID share register address 0002h = Direct data operation starting/ changing rate (upper): 0000h
			00h	
		Value write to ID share register address +3 (upper)	07h	Value written to ID share register address 0003h = Direct data operation starting/ changing rate (lower): 07D0h
			D0h	
		Value write to ID share register address +4 (upper)	00h	Value written to ID share register address 0004h = Direct data operation stopping deceleration (upper): 0000h
			00h	
		Value write to ID share register address +5 (upper)	13h	Value written to ID share register address 0005h = Direct data operation stopping deceleration (lower): 1388h
			88h	
Error check (lower)	A2h	Calculation result of CRC-16		
Error check (upper)	94h			

\*1 Number of registers = (number of ID share register addresses to be read + 1) × Share control number

- Number of register addresses to be read: 6 (0000h to 0005h)
- +1: Error check between servers
- Share control number: 2

\*2 Number of registers = (Share control number) × Number of ID share register addresses to be written

- Share control number: 2
- Number of register addresses to be written: 6 (0000h to 0005h)

\*3 Server address 1 (Share control local ID: 1)

\*4 Server address 2 (Share control local ID: 2)

**Note** Note that the number of registers in the ID share mode is calculated differently from that in other transmission modes of RS-485 communication.

## Response (ID share mode)

Field name		Data	Description	
Server address		0Fh	Same as query	
Function code		17h	Same as query	
Data	(Read) Number of data bytes	1Ch	Twice the number of registers in the query	
	*1	Value read from ID share register address (upper)	00h	Value read from ID share register address 0000h = Present alarm (upper): 0000h
		Value read from ID share register address (lower)	00h	
		Value read from ID share register address +1 (upper)	00h	Value read from ID share register address 0001h = Present alarm (lower): 0000h
		Value read from ID share register address +1 (lower)	00h	
		Value read from ID share register address +2 (upper)	00h	Value read from ID share register address 0002h = Driver temperature (upper): 0000h
		Value read from ID share register address +2 (lower)	00h	
		Value read from ID share register address +3 (upper)	01h	Value read from ID share register address 0003h = Driver temperature (lower): 017Fh
		Value read from ID share register address +3 (lower)	7Fh	
		Value read from ID share register address +4 (upper)	00h	Value read from ID share register address 0004h = Motor temperature (upper): 0000h
		Value read from ID share register address +4 (lower)	00h	
		Value read from ID share register address +5 (upper)	01h	Value read from ID share register address 0005h = Motor temperature (lower): 01AAh
		Value read from ID share register address +5 (lower)	AAh	
		Error check for between servers (lower) *3	A2h	Calculation result of CRC-16 (The value varies depending on the monitor value.)
		Error check for between servers (upper) *3	04h	
	*2	Value read from ID share register address (upper)	00h	Value read from ID share register address 0000h = Present alarm (upper): 0000h
		Value read from ID share register address (lower)	00h	
		Value read from ID share register address +1 (upper)	00h	Value read from ID share register address 0001h = Present alarm (lower): 0030h
		Value read from ID share register address +1 (lower)	30h	
		Value read from ID share register address +2 (upper)	00h	Value read from ID share register address 0002h = Driver temperature (upper): 0000h
		Value read from ID share register address +2 (lower)	00h	
		Value read from ID share register address +3 (upper)	01h	Value read from ID share register address 0003h = Driver temperature (lower): 01C2h
		Value read from ID share register address +3 (lower)	C2h	
		Value read from ID share register address +4 (upper)	00h	Value read from ID share register address 0004h = Motor temperature (upper): 0000h
		Value read from ID share register address +4 (lower)	00h	
		Value read from ID share register address +5 (upper)	02h	Value read from ID share register address 0005h = Motor temperature (lower): 021Ah
		Value read from ID share register address +5 (lower)	1Ah	
		Error check for between servers (lower) *3	ACH	Calculation result of CRC-16 (The value varies depending on the monitor value.)
Error check for between servers (upper) *3		AAh		

## ID share mode

Field name	Data	Description
Error check (lower)	00h	Calculation result of CRC-16
Error check (upper)	00h	

\*1 Server address 1 (Share control local ID: 1)

\*2 Server address 2 (Share control local ID: 2)

\*3 Whenever data is sent to each server, error check is performed on the data having sent until then.

# 9 Addresses and codes lists

Refer to the **AZ Series OPERATING MANUAL Function Edition** for addresses and codes not described in this chapter. This chapter describes the following.

- Addresses and codes specific to the mini Driver
- Addresses and codes not compatible with the mini Driver among those described in the **AZ series OPERATING MANUAL Function Edition**

## 9-1 Addresses and codes specific to the mini Driver

In addition to addresses and codes specific to the mini Driver, this section describes addresses and codes specific to the mini Driver among those described in the **AZ Series OPERATING MANUAL Function Edition**.

### ■ Monitor commands

Modbus communication Register address		Name	Description	Industrial network Command code																																				
Upper	Lower																																							
00D4h (212)	00D5h (213)	Direct I/O	Indicates the status of the extended input and the virtual input. (Arrangement of bits ⇨ p.46)	206Ah (8298)																																				
0148h (328)	0149h (329)	Main power supply voltage	Indicates the voltage of the main power supply. (1=0.1 V)	20A4h (8356)																																				
014Ah (330)	014Bh (331)	DIP SW	Indicates the input status of the function setting switch (SW1). The table below shows the relation between the read value and the function setting switch (SW1). <table border="1" style="margin: 10px auto;"> <thead> <tr> <th>READ value</th> <th>SW1-No.3</th> <th>SW1-No.2</th> <th>SW1-No.1</th> </tr> </thead> <tbody> <tr> <td>0</td> <td>ON</td> <td>ON</td> <td>ON</td> </tr> <tr> <td>1</td> <td>ON</td> <td>ON</td> <td>OFF</td> </tr> <tr> <td>2</td> <td>ON</td> <td>OFF</td> <td>ON</td> </tr> <tr> <td>3</td> <td>ON</td> <td>OFF</td> <td>OFF</td> </tr> <tr> <td>4</td> <td>OFF</td> <td>ON</td> <td>ON</td> </tr> <tr> <td>5</td> <td>OFF</td> <td>ON</td> <td>OFF</td> </tr> <tr> <td>6</td> <td>OFF</td> <td>OFF</td> <td>ON</td> </tr> <tr> <td>7</td> <td>OFF</td> <td>OFF</td> <td>OFF</td> </tr> </tbody> </table>	READ value	SW1-No.3	SW1-No.2	SW1-No.1	0	ON	ON	ON	1	ON	ON	OFF	2	ON	OFF	ON	3	ON	OFF	OFF	4	OFF	ON	ON	5	OFF	ON	OFF	6	OFF	OFF	ON	7	OFF	OFF	OFF	20A5h (8357)
READ value	SW1-No.3	SW1-No.2	SW1-No.1																																					
0	ON	ON	ON																																					
1	ON	ON	OFF																																					
2	ON	OFF	ON																																					
3	ON	OFF	OFF																																					
4	OFF	ON	ON																																					
5	OFF	ON	OFF																																					
6	OFF	OFF	ON																																					
7	OFF	OFF	OFF																																					
0150h (336)	0151h (337)	RS-485 Reception frame counter	Indicates the number of times that a message was received via RS-485 communication (Modbus).	20A8h (8360)																																				
0170h (368)	0171h (369)	I/O status 1	Indicates the ON-OFF status of the internal I/O. (Arrangement of bits ⇨ p.46)	20B8h (8376)																																				
0172h (370)	0173h (371)	I/O status 2		20B9h (8377)																																				
0174h (372)	0175h (373)	I/O status 3		20BAh (8378)																																				
0176h (374)	0177h (375)	I/O status 4		20BBh (8379)																																				
0178h (376)	0179h (377)	I/O status 5		20BCh (8380)																																				
017Ah (378)	017Bh (379)	I/O status 6		20BDh (8381)																																				
017Ch (380)	017Dh (381)	I/O status 7		20BEh (8382)																																				

Modbus communication Register address		Name	Description	Industrial network Command code
Upper	Lower			
017Eh (382)	017Fh (383)	I/O status 8	Indicates the ON-OFF status of the internal I/O. (Arrangement of bits ⇨ "I/O status")	20BFh (8383)
0A0Ah (2570)	0A0Bh (2571)	Alarm history details (R-I/O input)	Indicates the description of the alarm history specified by the "Alarm history details" of the maintenance command.	2505h (9477)

● **Direct I/O**

The arrangement of bits for direct I/O is indicated.

Modbus communication Register address	Description								Industrial network Command code
	Bit 15	Bit 14	Bit 13	Bit 12	Bit 11	Bit 10	Bit 9	Bit 8	
00D4h (212)	–	–	–	–	–	–	–	–	206Ah (8298)
	Bit 7	Bit 6	Bit 5	Bit 4	Bit 3	Bit 2	Bit 1	Bit 0	
	–	–	–	–	–	–	–	–	
00D5h (213)	Bit 15	Bit 14	Bit 13	Bit 12	Bit 11	Bit 10	Bit 9	Bit 8	
	VIR-IN3	VIR-IN2	VIR-IN1	VIR-IN0	–	–	–	–	
	Bit 7	Bit 6	Bit 5	Bit 4	Bit 3	Bit 2	Bit 1	Bit 0	
–	–	–	–	–	–	–	–	–	

● **I/O status**

The arrangement of bits for internal I/O is indicated.

**Input signals**

Modbus communication Register address	Description								Industrial network Command code
	Bit 15	Bit 14	Bit 13	Bit 12	Bit 11	Bit 10	Bit 9	Bit 8	
0170h (368)	SLIT	HOMES	RV-LS	FW-LS	RV-BLK	FW-BLK	–	–	20B8h (8376)
	Bit 7	Bit 6	Bit 5	Bit 4	Bit 3	Bit 2	Bit 1	Bit 0	
	SPD-LMT	CRNT-LMT	T-MODE	–	–	CCM	–	HMI	
0171h (369)	Bit 15	Bit 14	Bit 13	Bit 12	Bit 11	Bit 10	Bit 9	Bit 8	
	–	INFO-CLR	LAT-CLR	–	–	EL-PRST	P-PRESET	ALM-RST	
	Bit 7	Bit 6	Bit 5	Bit 4	Bit 3	Bit 2	Bit 1	Bit 0	
BREAK-ATSQ	PAUSE	STOP	STOP-COFF	CLR	C-ON	FREE	Not used	–	
0172h (370)	Bit 15	Bit 14	Bit 13	Bit 12	Bit 11	Bit 10	Bit 9	Bit 8	20B9h (8377)
	–	–	RV-PSH	FW-PSH	RV-SPD	FW-SPD	RV-POS	FW-POS	
	Bit 7	Bit 6	Bit 5	Bit 4	Bit 3	Bit 2	Bit 1	Bit 0	
RV-JOG-C	FW-JOG-C	RV-JOG-P	FW-JOG-P	RV-JOG-H	FW-JOG-H	RV-JOG	FW-JOG	–	
0173h (371)	Bit 15	Bit 14	Bit 13	Bit 12	Bit 11	Bit 10	Bit 9	Bit 8	
	D-SEL7	D-SEL6	D-SEL5	D-SEL4	D-SEL3	D-SEL2	D-SEL1	D-SEL0	
	Bit 7	Bit 6	Bit 5	Bit 4	Bit 3	Bit 2	Bit 1	Bit 0	
–	–	ZHOME	HOME	NEXT	–	SSTART	START	–	

Modbus communication Register address	Description								Industrial network Command code	
	Bit 15	Bit 14	Bit 13	Bit 12	Bit 11	Bit 10	Bit 9	Bit 8		
0174h (372)	Bit 15	Bit 14	Bit 13	Bit 12	Bit 11	Bit 10	Bit 9	Bit 8	20BAh (8378)	
	R15	R14	R13	R12	R11	R10	R9	R8		
	Bit 7	Bit 6	Bit 5	Bit 4	Bit 3	Bit 2	Bit 1	Bit 0		
	R7	R6	R5	R4	R3	R2	R1	R0		
0175h (373)	Bit 15	Bit 14	Bit 13	Bit 12	Bit 11	Bit 10	Bit 9	Bit 8		
	–	–	–	–	TEACH	–	–	–		
	Bit 7	Bit 6	Bit 5	Bit 4	Bit 3	Bit 2	Bit 1	Bit 0		
	M7	M6	M5	M4	M3	M2	M1	M0		
0176h (374)	Bit 15	Bit 14	Bit 13	Bit 12	Bit 11	Bit 10	Bit 9	Bit 8		20BBh (8379)
	–	–	–	–	–	–	–	–		
	Bit 7	Bit 6	Bit 5	Bit 4	Bit 3	Bit 2	Bit 1	Bit 0		
	–	–	–	–	–	–	–	–		
0177h (375)	Bit 15	Bit 14	Bit 13	Bit 12	Bit 11	Bit 10	Bit 9	Bit 8		
	–	–	–	–	–	–	–	–		
	Bit 7	Bit 6	Bit 5	Bit 4	Bit 3	Bit 2	Bit 1	Bit 0		
	–	–	–	–	–	–	–	–		

### Output signal

Modbus communication Register address	Description								Industrial network Command code	
	Bit 15	Bit 14	Bit 13	Bit 12	Bit 11	Bit 10	Bit 9	Bit 8		
0178h (376)	Bit 15	Bit 14	Bit 13	Bit 12	Bit 11	Bit 10	Bit 9	Bit 8	20BCh (8380)	
	MAREA	–	TIM	RND-ZERO	ZSG	RV-SLS	FW-SLS	RND-OVF		
	Bit 7	Bit 6	Bit 5	Bit 4	Bit 3	Bit 2	Bit 1	Bit 0		
	ORGN-STLD	PRST-STLD	PRST-DIS	–	–	ELPRST-MON	ABSPEN	HOME-END		
0179h (377)	Bit 15	Bit 14	Bit 13	Bit 12	Bit 11	Bit 10	Bit 9	Bit 8		
	AUTO-CD	CRNT	VA	TLC	–	IN-POS	–	SYS-BSY		
	Bit 7	Bit 6	Bit 5	Bit 4	Bit 3	Bit 2	Bit 1	Bit 0		
	INFO	MOVE	–	READY	SYS-RDY	ALM-B	ALM-A	CONST-OFF		
017Ah (378)	Bit 15	Bit 14	Bit 13	Bit 12	Bit 11	Bit 10	Bit 9	Bit 8		20BDh (8381)
	–	–	–	–	–	–	–	–		
	Bit 7	Bit 6	Bit 5	Bit 4	Bit 3	Bit 2	Bit 1	Bit 0		
	–	–	USR-OUT1	USR-OUT0	–	–	–	–		
017Bh (379)	Bit 15	Bit 14	Bit 13	Bit 12	Bit 11	Bit 10	Bit 9	Bit 8		
	–	–	–	–	–	–	MBC	MPS		
	Bit 7	Bit 6	Bit 5	Bit 4	Bit 3	Bit 2	Bit 1	Bit 0		
	AREA7	AREA6	AREA5	AREA4	AREA3	AREA2	AREA1	AREA0		

Modbus communication Register address	Description								Industrial network Command code
017Ch (380)	Bit 15	Bit 14	Bit 13	Bit 12	Bit 11	Bit 10	Bit 9	Bit 8	20BEh (8382)
	D-END7	D-END6	D-END5	D-END4	D-END3	D-END2	D-END1	D-END0	
	Bit 7	Bit 6	Bit 5	Bit 4	Bit 3	Bit 2	Bit 1	Bit 0	
	M-ACT7	M-ACT6	M-ACT5	M-ACT4	M-ACT3	M-ACT2	M-ACT1	M-ACT0	
017Dh (381)	Bit 15	Bit 14	Bit 13	Bit 12	Bit 11	Bit 10	Bit 9	Bit 8	
	M-CHG	–	DCMD-FULL	DCMD-RDY	–	NEXT-LAT	JUMP1-LAT	JUMP0-LAT	
	Bit 7	Bit 6	Bit 5	Bit 4	Bit 3	Bit 2	Bit 1	Bit 0	
	DELAY-BSY	SEQ-BSY	PAUSE-BSY	OPE-BSY	–	–	SPD-LMTD	CRNT-LMTD	
017Eh (382)	Bit 15	Bit 14	Bit 13	Bit 12	Bit 11	Bit 10	Bit 9	Bit 8	20BFh (8383)
	INFO-RBT	INFO-CFG	INFO-IOTEST	INFO-DSLMTD	–	–	–	–	
	Bit 7	Bit 6	Bit 5	Bit 4	Bit 3	Bit 2	Bit 1	Bit 0	
	–	–	INFO-ODO	INFO-TRIP	INFO-CULD1	INFO-CULD0	INFO-RV-OT	INFO-FW-OT	
017Fh (383)	Bit 15	Bit 14	Bit 13	Bit 12	Bit 11	Bit 10	Bit 9	Bit 8	
	INFO-NET-E	INFO-RND-E	INFO-EGR-E	–	INFO-PR-REQ	INFO-ZHOME	INFO-START	INFO-SPD	
	Bit 7	Bit 6	Bit 5	Bit 4	Bit 3	Bit 2	Bit 1	Bit 0	
	–	INFO-OLTIME	INFO-UVOLT	INFO-OVOLT	INFO-MTRTMP	INFO-DRVTMP	INFO-POSERR	INFO-USRIO	

## ■ Parameter R/W commands

Timing to update parameters are shown in the table.  
In this manual, each update timing is represented in an alphabet.

Notation	Description
A	Recalculation and setup are immediately executed when the parameter is written.
B	Recalculation and setup are executed when the operation is stopped.
C	Recalculation and setup are executed after Configuration is executed or the main power supply and control power supply are turned on again.
D	Recalculation and setup are executed after the main power supply and control power supply are turned on again.

### ● Base setting parameter

Modbus communication Register address		Name	Description	Update	Industrial network Command code	
Upper	Lower				READ	WRITE
03FAh (1018)	03FBh (1019)	Main power mode	<p>Sets the voltage mode of the main power supply. The voltage mode of the main power supply is discriminated in 50 ms after the main power supply is turned on. Set this parameter to "0: 24 VDC" or "1: 48 VDC" when the main power supply starts up slowly or the voltage of the main power supply is unstable.</p> <p><b>[Setting range]</b>            -1: Automatic discrimination (discriminates the input main power supply voltage automatically.)            0: 24 VDC            1: 48 VDC            [Initial value: -1]</p>	D	01FDh (509)	11FDh (4605)

### ● Information setting parameters

Modbus communication Register address		Name	Description	Update	Industrial network Command code	
Upper	Lower				READ	WRITE
0356h (854)	0357h (855)	Overvoltage information (INFO-OVOLT)	<p>Sets the condition in which the overvoltage information (INFO-OVOLT) is generated.</p> <p><b>[Setting range]</b>            140 to 630 (1=0.1 V)            [Initial value: 630]</p>	A	01ABh (427)	11ABh (4523)
0358h (856)	0359h (857)	Undervoltage information (INFO-UVOLT)	<p>Sets the condition in which the undervoltage information (INFO-UVOLT) is generated.</p> <p><b>[Setting range]</b>            140 to 630 (1=0.1 V)            [Initial value: 140]</p>	A	01ACh (428)	11ACh (4524)

● LED status indication setting parameters

Modbus communication Register address		Name	Description	Update	Industrial network Command code	
Upper	Lower				READ	WRITE
03D0h (976)	03D1h (977)	Number of times the GREEN LED blinks at booting	Sets the number of times that the C-DAT/C-ERR LED blinks in green when the main power supply is turned on. <b>[Setting range]</b> 0 to 9 times [Initial value: 0]	A	01E8h (488)	11E8h (4584)
03D2h (978)	03D3h (979)	Number of times the RED LED blinks at booting	Sets the number of times that the C-DAT/C-ERR LED blinks in red when the main power supply is turned on. <b>[Setting range]</b> 0 to 9 times [Initial value: 0]	A	01E9h (489)	11E9h (4585)
03D4h (980)	03D5h (981)	Number of times the BLUE LED blinks at booting	Sets the number of times that the C-DAT/C-ERR LED blinks in blue when the main power supply is turned on. <b>[Setting range]</b> 0 to 9 times [Initial value: 0]	A	01EAh (490)	11EAh (4586)
03EAh (1002)	03EBh (1003)	LED-OUT mode	Sets the information to be indicated by the POWER/ALARM LED and the C-DAT/C-ERR LED. <b>[Setting range]</b> Check with the table below. [Initial value: 1]	A	01F5h (501)	11F5h (4597)
03F4h (1012)	03F5h (1013)	LED-OUT-BLUE function (I/O status output)	Selects the output signal to be indicated by the blue LED. * <b>[Setting range]</b> Output signals ⇨ p.53 [Initial value: 128 (CONST-OFF)]	A	01FAh (506)	11FAh (4602)
03F6h (1014)	03F7h (1015)	LED-OUT-BLUE inverting mode (I/O status output)	Changes the ON-OFF status of the output signal to be indicated by the blue LED. <b>[Setting range]</b> 0: Not invert 1: Invert [Initial value: 0]	A	01FBh (507)	11FBh (4603)
03F8h (1016)	03F9h (1017)	LED (PWR/C-DAT) color changing	Sets the lighting colors of the POWER/ALARM LED and the C-DAT/C-ERR LED. <b>[Setting range]</b> 0: Green 1: White [Initial value: 0]	A	01FCh (508)	11FCh (4604)

\* This is enabled when the "LED-OUT mode" parameter is set to "0."

Setting range of "LED-OUT mode" parameter

Setting value	POWER/ALARM LED	C-DAT/C-ERR LED
-3	LED is not lightened *	
-2	LED is not lightened (except when an alarm is generated) *	
-1	Normal operation	LED is not lightened
0		I/O status
1		Normal operation

\* The POWER/ALARM LED is lit in red for maximum one second when the main power supply is turned on.

- **RS-485 communication setting parameter**

Modbus communication Register address		Name	Description	Update	Industrial network Command code	
Upper	Lower				READ	WRITE
138Ch (5004)	138Dh (5005)	Communication error detection (Modbus)	When the RS-485 communication error has occurred for the set number of times, an alarm of RS-485 communication error is generated. <b>[Setting range]</b> 0 (disable), 1 to 10 times [Initial value: 3]	A	09C6h (2502)	19C6h (6598)

## 9-2 Addresses and codes not compatible with the mini Driver

- **Monitor command**

Modbus communication Register address		Name	Industrial network Command code
Upper	Lower		
014Eh (334)	014Fh (335)	ROT SW1	20A7h (8359)

- **Power removal function setting parameters**

All parameters are disabled (not compatible).

- **I/O parameters**

Modbus communication Register address		Name	Industrial network Command code	
Upper	Lower		READ	WRITE
0E18h (3608)	0E19h (3609)	PLS-XMODE pulse multiplying factor	070Ch (1804)	170Ch (5900)
0E26h (3622)	0E27h (3623)	PLS-LOST check algorithm	0713h (1811)	1713h (5907)
0E28h (3624)	0E29h (3625)	MON-REQ0 output data selection	0714h (1812)	1714h (5908)
0E2Ah (3626)	0E2Bh (3627)	MON-REQ1 output data selection	0715h (1813)	1715h (5909)
0E2Ch (3628)	0E2Dh (3629)	PLS-OUT output data selection	0716h (1814)	1716h (5910)
0E2Eh (3630)	0E2Fh (3631)	PLS-OUT maximum frequency	0717h (1815)	1717h (5911)

- **Direct I/O setting parameters**

All parameters are disabled (not compatible).

- **Extended input setting parameters**

All parameters are disabled (not compatible).

- **Differential output setting parameters**

All parameters are disabled (not compatible).

## ■ Driver mode setting parameters

Modbus communication Register address		Name	Industrial network Command code	
Upper	Lower		READ	WRITE
03E0h (992)	03E1h (993)	PULSE-I/F mode selection	01F0h (496)	11F0h (4592)

## 9-3 I/O signals assignment list

### ■ Input signals

To assign signals via industrial network, use the “assignment numbers” in the table instead of the signal names.

Assignment number	Signal name	Assignment number	Signal name	Assignment number	Signal name
0	Not used	35	NEXT	65	M1
1	FREE	36	HOME	66	M2
2	C-ON	37	ZHOME	67	M3
3	CLR	40	D-SEL0	68	M4
4	STOP-COFF	41	D-SEL1	69	M5
5	STOP	42	D-SEL2	70	M6
6	PAUSE	43	D-SEL3	71	M7
7	BREAK-ATSQ	44	D-SEL4	75	TEACH
8	ALM-RST	45	D-SEL5	80	R0
9	P-PRESET	46	D-SEL6	81	R1
10	EL-PRST	47	D-SEL7	82	R2
13	LAT-CLR	48	FW-JOG	83	R3
14	INFO-CLR	49	RV-JOG	84	R4
16	HMI	50	FW-JOG-H	85	R5
18	CCM	51	RV-JOG-H	86	R6
21	T-MODE	52	FW-JOG-P	87	R7
22	CRNT-LMT	53	RV-JOG-P	88	R8
23	SPD-LMT	54	FW-JOG-C	89	R9
26	FW-BLK	55	RV-JOG-C	90	R10
27	RV-BLK	56	FW-POS	91	R11
28	FW-LS	57	RV-POS	92	R12
29	RV-LS	58	FW-SPD	93	R13
30	HOMES	59	RV-SPD	94	R14
31	SLIT	60	FW-PSH	95	R15
32	START	61	RV-PSH		
33	SSTART	64	M0		

## ■ Output signals

To assign signals via industrial network, use the “assignment numbers” in the table instead of the signal names.

Assignment number	Signal name	Assignment number	Signal name	Assignment number	Signal name
0	Not used	56	FW-POS_R	145	ABSPEN
1	FREE_R	57	RV-POS_R	146	ELPRST-MON
2	C-ON_R	58	FW-SPD_R	149	PRST-DIS
3	CLR_R	59	RV-SPD_R	150	PRST-STLD
4	STOP-COFF_R	60	FW-PSH_R	151	ORGN-STLD
5	STOP_R	61	RV-PSH_R	152	RND-OVF
6	PAUSE_R	64	M0_R	153	FW-SLS
7	BREAK-ATSQ_R	65	M1_R	154	RV-SLS
8	ALM-RST_R	66	M2_R	155	ZSG
9	P-PRESET_R	67	M3_R	156	RND-ZERO
10	EL-PRST_R	68	M4_R	157	TIM
13	LAT-CLR_R	69	M5_R	159	MAREA
14	INFO-CLR_R	70	M6_R	160	AREA0
16	HMI_R	71	M7_R	161	AREA1
18	CCM_R	75	TEACH_R	162	AREA2
21	T-MODE_R	80	R0_R	163	AREA3
22	CRNT-LMT_R	81	R1_R	164	AREA4
23	SPD-LMT_R	82	R2_R	165	AREA5
26	FW-BLK_R	83	R3_R	166	AREA6
27	RV-BLK_R	84	R4_R	167	AREA7
28	FW-LS_R	85	R5_R	168	MPS
29	RV-LS_R	86	R6_R	169	MBC
30	HOMES_R	87	R7_R	180	USR-OUT0
31	SLIT_R	88	R8_R	181	USR-OUT1
32	START_R	89	R9_R	192	CRNT-LMTD
33	SSTART_R	90	R10_R	193	SPD-LMTD
35	NEXT_R	91	R11_R	196	OPE-BSY
36	HOME_R	92	R12_R	197	PAUSE-BSY
37	ZHOME_R	93	R13_R	198	SEQ-BSY
40	D-SEL0_R	94	R14_R	199	DELAY-BSY
41	D-SEL1_R	95	R15_R	200	JUMP0-LAT
42	D-SEL2_R	128	CONST-OFF	201	JUMP1-LAT
43	D-SEL3_R	129	ALM-A	202	NEXT-LAT
44	D-SEL4_R	130	ALM-B	204	DCMD-RDY
45	D-SEL5_R	131	SYS-RDY	205	DCMD-FULL
46	D-SEL6_R	132	READY	207	M-CHG
47	D-SEL7_R	134	MOVE	208	M-ACT0
48	FW-JOG_R	135	INFO	209	M-ACT1
49	RV-JOG_R	136	SYS-BSY	210	M-ACT2
50	FW-JOG-H_R	138	IN-POS	211	M-ACT3
51	RV-JOG-H_R	140	TLC	212	M-ACT4
52	FW-JOG-P_R	141	VA	213	M-ACT5
53	RV-JOG-P_R	142	CRNT	214	M-ACT6
54	FW-JOG-C_R	143	AUTO-CD	215	M-ACT7
55	RV-JOG-C_R	144	HOME-END	216	D-END0

Assignment number	Signal name
217	D-END1
218	D-END2
219	D-END3
220	D-END4
221	D-END5
222	D-END6
223	D-END7
224	INFO-USRIO
225	INFO-POSERR
226	INFO-DRVTMP
227	INFO-MTRTMP
228	INFO-OVOLT
229	INFO-UVOLT
230	INFO-OLTIME
232	INFO-SPD
233	INFO-START
234	INFO-ZHOME
235	INFO-PR-REQ
237	INFO-EGR-E
238	INFO-RND-E
239	INFO-NET-E
240	INFO-FW-OT
241	INFO-RV-OT
242	INFO-CULD0
243	INFO-CULD1
244	INFO-TRIP
245	INFO-ODO
252	INFO-DSLMTD
253	INFO-IOTEST
254	INFO-CFG
255	INFO-RBT

# 10 Inspection and maintenance

---

## 10-1 Inspection

It is recommended that periodic inspections are conducted for the items listed below after each operation of the motor. If an abnormality is found, discontinue any use and contact your nearest Oriental Motor sales office.

### ■ Inspection item

- Check if the openings in the driver are clogged.
- Check if any of the mounting screws secured the driver is loose.
- Check if any of the connection parts of the driver is loose.
- Check if dust is deposited on the driver.
- Check if the driver has unusual smells or appearance defects.



The driver uses semiconductor components. Static electricity may damage the semiconductor components of the driver, so be extremely careful when handling them.

## 10-2 Warranty

Check on the Oriental Motor Website for the product warranty.

## 10-3 Disposal

Dispose the product correctly in accordance with laws and regulations, or instructions of local governments.

# 11 Troubleshooting

## 11-1 Detection of communication errors

This driver has functions to detect abnormalities that may occur in communication, including two types: communication errors and alarms.

### ■ Communication errors

If a communication error of the RS-485 communication error (error code 84h) occurs, the C-DAT/C-ERR LED will be lit in red and the POWER/ALARM LED will blink in blue. When any other communication error occurs, all LEDs remain off. The communication error can be checked with the "Communication error history" command or the **MEXE02**.

**Note** The communication error history is cleared when the main power supply and control power supply of the driver is turned off because it is stored in RAM.

### ● Communication error list

#### For RS-485 communication

Refer to the **AZ Series OPERATING MANUAL Function Edition** for details about causes.

Type of communication error	Error code	Cause
RS-485 communication error	84h	A transmission error was detected.
Command not yet defined	88h	An exception response (exception code 01h, 02h) was detected.
Execution disable due to user I/F communication in progress	89h	An exception response (exception code 04h) was detected.
Execution disable due to non-volatile memory processing in progress	8Ah	
Out of setting range	8Ch	An exception response (exception code 03h, 04h) was detected.
Command execute disable	8Dh	An exception response (exception code 04h) was detected.

#### For industrial network

Error code	Type of communication error	Cause	Remedial action
84h	RS-485 communication error	One of the following errors was detected. <ul style="list-style-type: none"> <li>• Framing error</li> <li>• BCC error</li> </ul>	<ul style="list-style-type: none"> <li>• Check the connection with the network converter.</li> <li>• Check the setting of RS-485 communication.</li> </ul>
88h	Command not yet defined	A command requested by the host controller could not be executed because of being undefined.	<ul style="list-style-type: none"> <li>• Check the setting value for the command.</li> <li>• Check the flame configuration.</li> </ul>
89h	Execution disable due to user I/F communication in progress	A command requested by the host controller could not be executed because the driver and the <b>MEXE02</b> was being communicated.	Wait until the <b>MEXE02</b> is completed processing.
8Ah	Execution disable due to non-volatile memory processing in progress	A command could not be executed because the driver was under processing of the non-volatile memory. <ul style="list-style-type: none"> <li>• Internal processing was in progress. (SYS-BSY is ON.)</li> <li>• An alarm of the EEPROM error was being generated.</li> </ul>	<ul style="list-style-type: none"> <li>• Wait until the internal processing is completed.</li> <li>• When the EEPROM error occurred, initialize all parameters using the <b>MEXE02</b> or via RS-485 communication.</li> </ul>

Error code	Type of communication error	Cause	Remedial action
8Ch	Out of setting range	The setting data requested by the host controller could not be executed due to out of range.	Check the setting data.
8Dh	Command execute disable	When the command is unable to execute, it was tried to execute.	Check the driver status.

■ **Alarms related to communication**

If an alarm is generated, the ALM-A output is turned ON and the ALM-B output is turned OFF to stop the motor. At the same time, the POWER/ALARM LED blinks in red.

● **Alarm lists related to communication**

**For RS-485 communication**

Alarm code	Alarm type	Cause
84h	RS-485 communication error	The RS-485 communication error occurred consecutively by the number of times set in the "Communication error detection (Modbus)" parameter.
85h	RS-485 communication timeout	The time set in the "Communication timeout (Modbus)" parameter has elapsed, and yet the communication could not be established with the host controller.

**For industrial network**

Alarm code	Alarm type	Cause
81h	Network bus error	The host network of the network converter was in a disconnected state while the motor was operated.
83h	Communication switch setting error	The setting of the function setting switch SW1-No.3 was out of specifications.
84h	RS-485 communication error	A communication error with the network converter occurred three times consecutively.
85h	RS-485 communication timeout	Communication with the network converter was not performed for more than 200 ms.
8Eh	Network converter error	An alarm was generated in the network converter.

## 11-2 Alarm

If an alarm specific to the mini Driver is generated, the motor stops. The POWER/ALARM LED blinks in red simultaneously. At this time, the motor current is cut off and the motor holding force is lost. When an electromagnetic brake motor is used, the electromagnetic brake is in a state of holding the motor shaft.

Before resetting an alarm, always remove the cause of the alarm and ensure safety, and perform one of the reset operations specified below.

- Execute the alarm reset via RS-485 communication.
- Turn the ALM-RST input ON. (It is enabled at the ON edge.)
- Execute the alarm reset using the **MEXE02**.
- Turn off the main power supply and the control power supply, and on again. (The main power supply only if the control power supply is not connected)

This section explains alarms specific to the mini Driver. Refer to the **AZ Series OPERATING MANUAL Function Edition** when any other alarm not described here is generated.

Alarm code	Number of LED blinks	Alarm type	Cause	Remedial action	How to reset
22h	3	Overvoltage	<ul style="list-style-type: none"> <li>• The voltage of the main power supply exceeded the permissible value (*).</li> <li>• A large load inertia was suddenly stopped.</li> <li>• Vertical operation (elevating operation) was performed.</li> </ul>	<ul style="list-style-type: none"> <li>• Check the input voltage of the main power supply.</li> <li>• Decrease the load.</li> <li>• Increase the acceleration/ deceleration time or slow the acceleration/deceleration rate.</li> </ul>	Any of reset operations
29h	9	CPU peripheral circuit error	<ul style="list-style-type: none"> <li>• A temperature significantly higher or lower than the specifications was detected.</li> <li>• The driver internal circuit was damaged.</li> </ul>	<ul style="list-style-type: none"> <li>• Reconsider the ambient temperature and ventilation condition.</li> <li>• Turn off the main power supply and the control power supply, and check if the driver is damaged. After that, turn on the main power supply and the control power supply again. If the alarm has still not reset, the driver may be damaged. Contact your nearest Oriental Motor sales office.</li> </ul>	Turn on the main power supply and control power supply again

\* It is 36 VDC when the "Main power mode" parameter is set to "24 VDC," and 63 VDC when it is set to "48 VDC."

## 11-3 Information

The driver is equipped with a function to generate information output before an alarm is generated.

If information is generated, the POWER/ALARM LED blinks in blue.

This section explains information specific to the mini Driver. Refer to the **AZ** Series [OPERATING MANUAL Function Edition](#) when information not included here is generated.

Information item	Information bit output signal	Cause	Clear condition
Overvoltage	INFO-OVOLT	<ul style="list-style-type: none"> <li>• The voltage of the main power supply exceeded the value set in the "Overvoltage information" parameter.</li> <li>• A large load inertia was suddenly stopped.</li> <li>• Vertical operation (elevating operation) was performed.</li> </ul>	The voltage of the main power supply fell below the value set in the "Overvoltage information" parameter.
Undervoltage	INFO-UVOLT	<ul style="list-style-type: none"> <li>• The voltage of the main power supply fell below the value set in the "Undervoltage information" parameter.</li> <li>• The main power supply was shut off momentarily or a voltage was insufficient.</li> </ul>	The voltage of the main power supply exceeded the value set in the "Undervoltage information" parameter.

### Related parameter

Name	Description	Initial value
Overvoltage information (INFO-OVOLT)	Sets the condition in which the overvoltage information (INFO-OVOLT) is generated. <b>[Setting range]</b> 140 to 630 (1=0.1 V)	630
Undervoltage information (INFO-UVOLT)	Sets the condition in which the undervoltage information (INFO-UVOLT) is generated. <b>[Setting range]</b> 140 to 630 (1=0.1 V)	140

## 11-4 Troubleshooting and remedial actions

In motor operation, the motor or the driver may not operate properly due to an improper setting or wrong connection.

When the motor cannot be operated properly, refer to the contents provided in this chapter and take an appropriate remedial action.

If the problem persists, contact your nearest Oriental Motor sales office.

Phenomenon	Possible cause	Remedial action
<ul style="list-style-type: none"> <li>• The motor is not excited.</li> <li>• The motor output shaft can be rotated by hand.</li> </ul>	Connection error of the motor cable.	Check the motor connection.
	The FREE input is being ON.	Turn the FREE input OFF.
The motor has a holding torque even if it is put into a non-excitation state.	Effect of dynamic brake.	If the motor is put into a non-excitation state using the C-ON input or the STOP-COFF input, the motor windings are brought into a state of being short-circuited inside the driver, generating a larger holding torque than when no current is supplied (dynamic brake). To release the dynamic brake, shut off the main power supply and control power supply or turn the FREE input ON.
The motor does not rotate.	When an electromagnetic brake motor is used, the electromagnetic brake is in a state of holding the motor shaft.	<ul style="list-style-type: none"> <li>• Check the connection of the electromagnetic brake.</li> <li>• Make the input voltage of the control power supply higher than 22.8 VDC.</li> </ul>
	The position (travel amount) is not set in the operation data when positioning operation is performed.	Check the operation data.
	When JOG operation, high-speed JOG operation, or continuous macro operation is performed, the input in the forward direction and that in the reverse direction are simultaneously ON.	Turn both inputs in the forward direction and the reverse direction OFF, and then turn either one ON.
	The STOP input is being ON.	Turn the STOP input OFF.
The motor rotates in the direction opposite to the specified direction.	The "Motor rotation direction" parameter is set wrongly.	Check the setting of the "Motor rotation direction" parameter.
The gearhead output shaft rotates in the direction opposite to the motor.	A geared motor that rotates in the direction opposite to the motor output shaft is used.	<ul style="list-style-type: none"> <li>• With the <b>TS</b> geared type, the gearhead output shaft rotates in the direction opposite to the motor when the gear ratio is 20 or 30.</li> <li>• With the Harmonic geared type, the gearhead output shaft always rotates in the direction opposite to the motor.</li> </ul>
Motor operation is unstable.	Connection error of the motor cable or the power supply cable.	Check the connections for the driver, the motor, and the main power supply.
	A value set in the "Base current" parameter is too low.	Check the setting of the "Base current" parameter. If the motor current value is low with respect to a load, the torque will also be low and the operation will be unstable.
	The "Main power mode" parameter is set wrongly.	Check the setting of the "Main power mode" parameter.
	The main power supply starts up slowly or the voltage of the main power supply is unstable.	Set the "Main power mode" parameter to "0: 24 VDC" or "1: 48 VDC" according to the rated voltage of the main power supply.

Phenomenon	Possible cause	Remedial action
Motor vibration is too large.	The load is small.	Lower the current with the "Base current" parameter. If the motor output torque is too large with respect to a load, vibration will increase.
	The "Main power mode" parameter is set wrongly.	Check the setting of the "Main power mode" parameter.
	The main power supply starts up slowly or the voltage of the main power supply is unstable.	Set the "Main power mode" parameter to "0: 24 VDC" or "1: 48 VDC" according to the rated voltage of the main power supply.
The electromagnetic brake is not put into a state of releasing the motor shaft.	The power is not supplied to the electromagnetic brake.	Check the connection of the electromagnetic brake.
	A voltage for the electromagnetic brake is insufficient.	Make the input voltage of the control power supply higher than 22.8 VDC.



When an alarm is being generated, check the alarm message via RS-485 communication or using the **MEXE02**.



## ■ Connection cables/Flexible connection cables (For AZM46, AZM48, AZM66, AZM69)

These cables are used when connecting a motor and a driver.  
The figure shows an example when the electromagnetic brake motor is used.

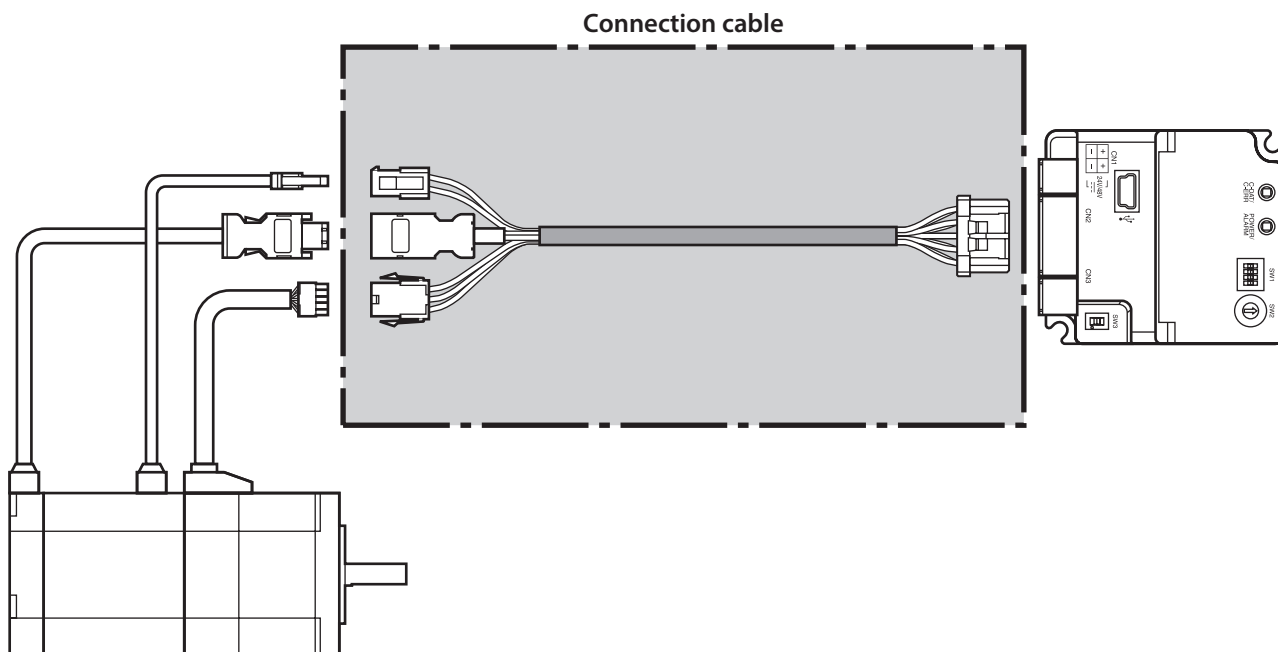

When installing the motor on a moving part, use a flexible cable.

### ● Connection cables

#### For motor/encoder

Model	Length [m (ft.)]
CCM005Z2ABF	0.5 (1.6)
CCM010Z2ABF	1 (3.3)
CCM030Z2ABF	3 (9.8)
CCM050Z2ABF	5 (16.4)
CCM100Z2ABF	10 (32.8)

#### For motor/encoder/electromagnetic brake

Model	Length [m (ft.)]
CCM005Z2ACF	0.5 (1.6)
CCM010Z2ACF	1 (3.3)
CCM030Z2ACF	3 (9.8)
CCM050Z2ACF	5 (16.4)
CCM100Z2ACF	10 (32.8)

### ● Flexible connection cables

#### For motor/encoder

Model	Length [m (ft.)]
CCM005Z2ABR	0.5 (1.6)
CCM010Z2ABR	1 (3.3)
CCM030Z2ABR	3 (9.8)
CCM050Z2ABR	5 (16.4)
CCM100Z2ABR	10 (32.8)

#### For motor/encoder/electromagnetic brake

Model	Length [m (ft.)]
CCM005Z2ACR	0.5 (1.6)
CCM010Z2ACR	1 (3.3)
CCM030Z2ACR	3 (9.8)
CCM050Z2ACR	5 (16.4)
CCM100Z2ACR	10 (32.8)

## ■ Extension cables/Flexible extension cables

These cables are used when extending a connection cable (add between the driver and connection cable).  
 Use if the length of the connection cable used is not enough when extending the distance between a motor and a driver.  
 The extension cables and the flexible extension cables are common to all motors.  
 The figure shows an example when the **AZM14** motor is connected.

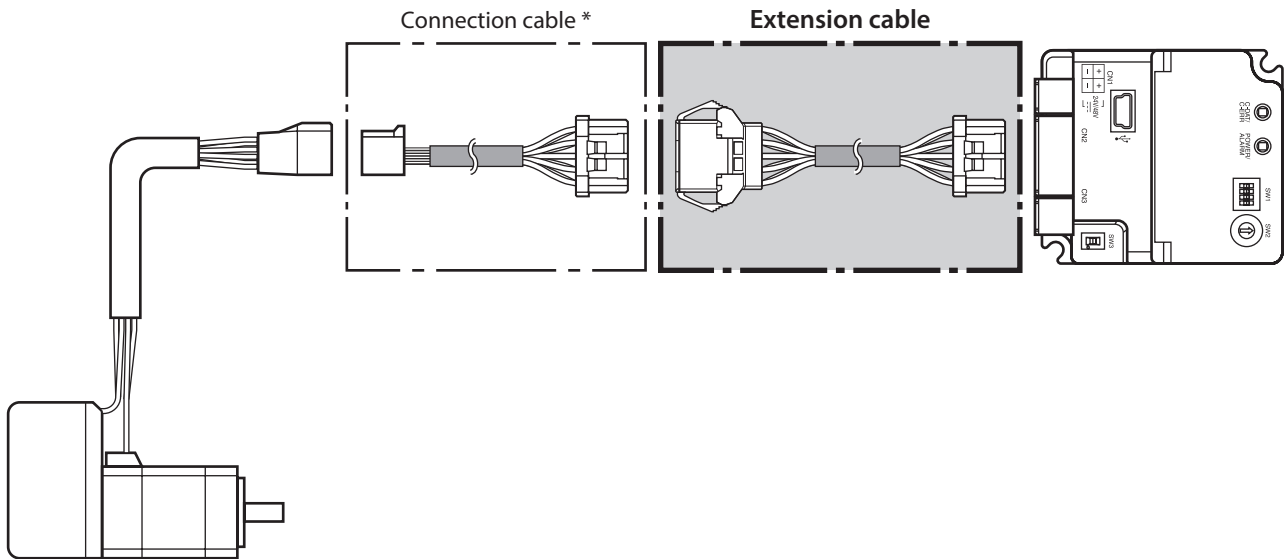

\* Use the connection cable used.



- When installing the motor on a moving part, use a flexible cable.
- When extending the wiring length by connecting an extension cable to the connection cable, make the total cable length 10 m (32.8 ft.) or less.

### ● Extension cables

Model	Length [m (ft.)]
<b>CCM010Z2ADFT</b>	1 (3.3)
<b>CCM030Z2ADFT</b>	3 (9.8)
<b>CCM050Z2ADFT</b>	5 (16.4)

### ● Flexible extension cables

Model	Length [m (ft.)]
<b>CCM010Z2ADRT</b>	1 (3.3)
<b>CCM030Z2ADRT</b>	3 (9.8)
<b>CCM050Z2ADRT</b>	5 (16.4)

## 12-2 Connection cables (For connector type)

### ■ Connection cables/Flexible connection cables

These cables are used when connecting a motor and a driver.

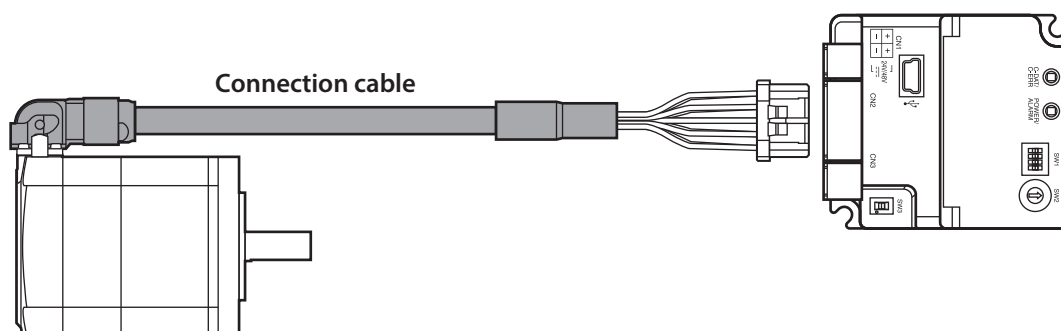

The model name of the connection cable varies depending on the outlet direction from the motor. Refer to the figures below.

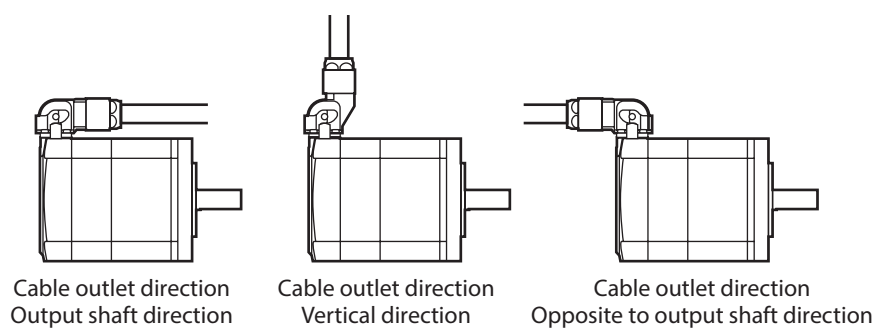

When installing the motor on a moving part, use a flexible cable.

### ● Connection cables

Length [m (ft.)]	Cable outlet direction		
	Output shaft direction	Vertical direction	Opposite to output shaft direction
0.2 (0.7)	<b>CCM002Z1EFF</b>	<b>CCM002Z1EVF</b>	<b>CCM002Z1EBF</b>
0.5 (1.6)	<b>CCM005Z1EFF</b>	<b>CCM005Z1EVF</b>	<b>CCM005Z1EBF</b>
1 (3.3)	<b>CCM010Z1EFF</b>	<b>CCM010Z1EVF</b>	<b>CCM010Z1EBF</b>
2 (6.6)	<b>CCM020Z1EFF</b>	<b>CCM020Z1EVF</b>	<b>CCM020Z1EBF</b>
3 (9.8)	<b>CCM030Z1EFF</b>	<b>CCM030Z1EVF</b>	<b>CCM030Z1EBF</b>
5 (16.4)	<b>CCM050Z1EFF</b>	<b>CCM050Z1EVF</b>	<b>CCM050Z1EBF</b>
7 (23.0)	<b>CCM070Z1EFF</b>	<b>CCM070Z1EVF</b>	<b>CCM070Z1EBF</b>
10 (32.8)	<b>CCM100Z1EFF</b>	<b>CCM100Z1EVF</b>	<b>CCM100Z1EBF</b>

● Flexible connection cables

Length [m (ft.)]	Cable outlet direction		
	Output shaft direction	Vertical direction	Opposite to output shaft direction
0.5 (1.6)	<b>CCM005Z1EFR</b>	<b>CCM005Z1EVR</b>	<b>CCM005Z1EBR</b>
1 (3.3)	<b>CCM010Z1EFR</b>	<b>CCM010Z1EVR</b>	<b>CCM010Z1EBR</b>
2 (6.6)	<b>CCM020Z1EFR</b>	<b>CCM020Z1EVR</b>	<b>CCM020Z1EBR</b>
3 (9.8)	<b>CCM030Z1EFR</b>	<b>CCM030Z1EVR</b>	<b>CCM030Z1EBR</b>
5 (16.4)	<b>CCM050Z1EFR</b>	<b>CCM050Z1EVR</b>	<b>CCM050Z1EBR</b>
7 (23.0)	<b>CCM070Z1EFR</b>	<b>CCM070Z1EVR</b>	<b>CCM070Z1EBR</b>
10 (32.8)	<b>CCM100Z1EFR</b>	<b>CCM100Z1EVR</b>	<b>CCM100Z1EBR</b>

■ Extension cables/Flexible extension cables

These cables are used when extending a connection cable (add between the driver and connection cable). Use if the length of the connection cable used is not enough when extending the distance between a motor and a driver.

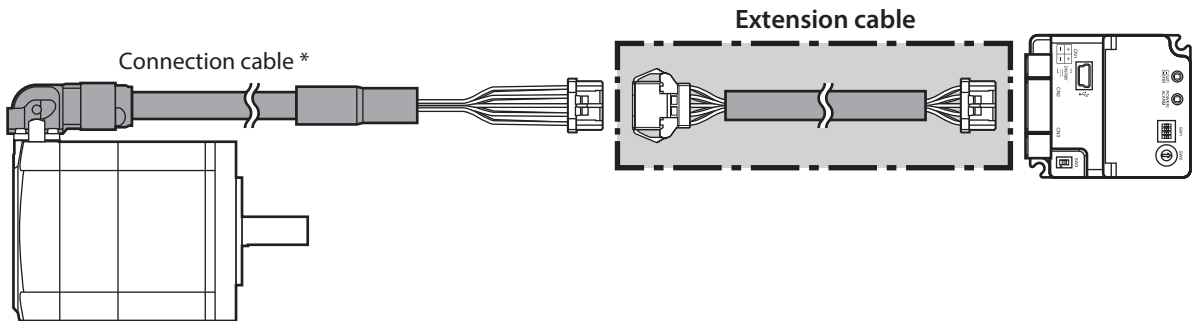

\* Use the connection cable used.



- When installing the motor on a moving part, use a flexible cable.
- When extending the wiring length by connecting an extension cable to the connection cable, make the total cable length 10 m (32.8 ft.) or less.

● Extension cables

Model	Length [m (ft.)]
<b>CCM010Z2ADFT</b>	1 (3.3)
<b>CCM030Z2ADFT</b>	3 (9.8)
<b>CCM050Z2ADFT</b>	5 (16.4)

● Flexible extension cables

Model	Length [m (ft.)]
<b>CCM010Z2ADRT</b>	1 (3.3)
<b>CCM030Z2ADRT</b>	3 (9.8)
<b>CCM050Z2ADRT</b>	5 (16.4)

## 12-3 RS-485 communication cables

These cables are used when connecting a driver with a network converter or robot controller **MRC01**.

Model	Length [m (ft.)]
<b>CC02FLT6</b>	2 (6.6)
<b>CC05FLT6</b>	5 (16.4)



These cables cannot be used for connection between drivers.

## 12-4 Power supply cable

This cable is used when connecting a driver to power supplies.

Model: **LCD06ZZAY** [0.6 m (2 ft.)]

# 13 Reference materials

## 13-1 Timing chart

### ■ Power activation

- When a control power supply is not connected

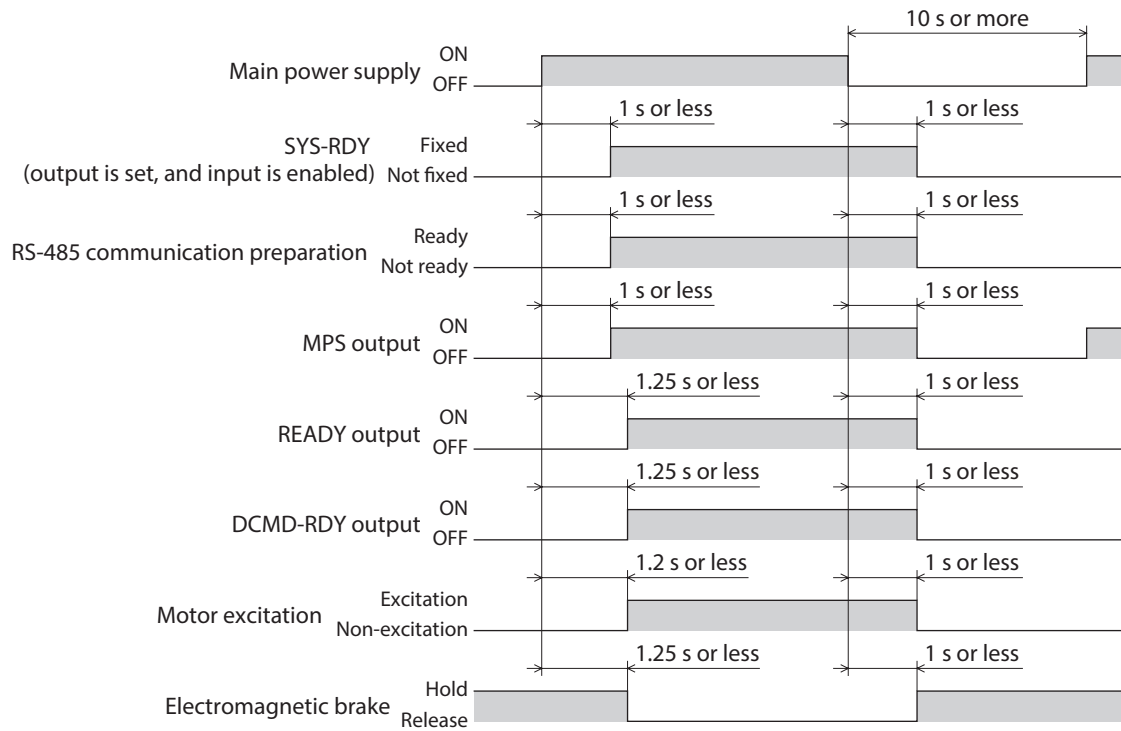

● When a control power supply is connected

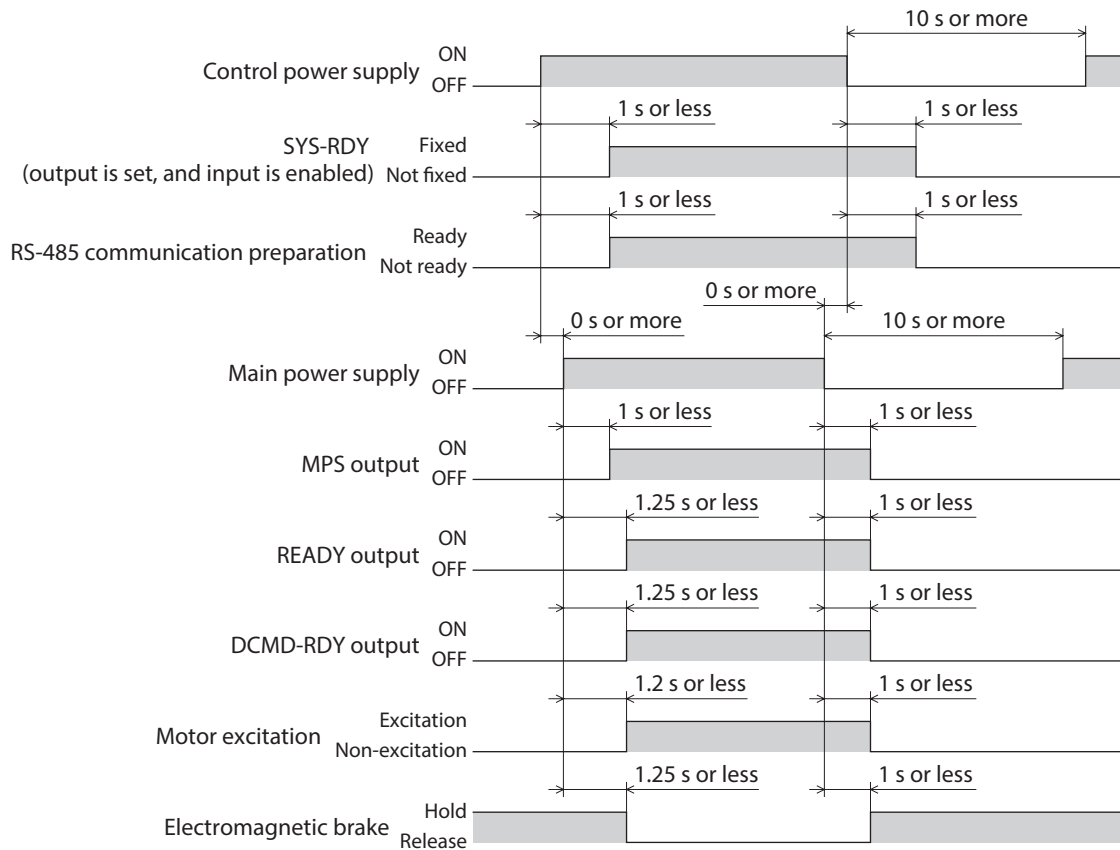

■ Excitation

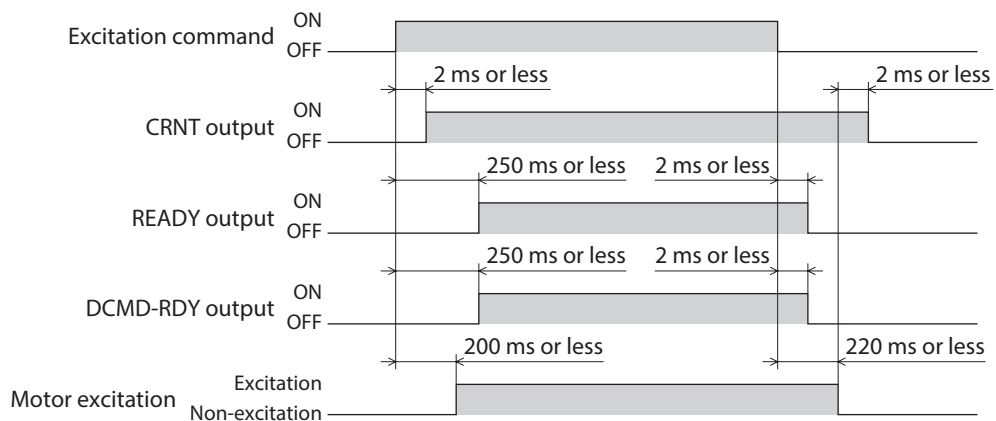

## 13-2 Specifications

### ■ Product specifications

Main power supply	Rated voltage	24 VDC±5 % 48 VDC±5 %
	Input current	0.4 to 3.7 A *1
	Allowable operating voltage	24 VDC input: 20 to 32 VDC (22.8 to 32 VDC) *2 48 VDC input: 40 to 55 VDC
Control power supply	Rated voltage	24 VDC±5 % 48 VDC±5 %
	Input current	0.15 A (0.4 A) *3
	Allowable operating voltage	24 VDC input: 20 to 32 VDC (22.8 to 32 VDC) *2 48 VDC input: 40 to 55 VDC

\*1 The input current varies depending on the motor combined. Refer to p.17.

\*2 The value in parentheses ( ) is the one when the electromagnetic brake motor is connected.

\*3 The value in parentheses ( ) is the one when the electromagnetic brake motor is connected. The **AZM46** type is 0.23 A.

### ■ General specifications

Degree of protection		IP10
Operating environment	Ambient temperature	0 to +50 °C [+32 to +122 °F] (non-freezing)
	Humidity	85 % or less (non-condensing)
	Altitude	Up to 1,000 m (3,300 ft.) above sea level
	Surrounding atmosphere	No corrosive gas, dust, water or oil.
Storage environment Shipping environment	Ambient temperature	-25 to +70 °C [-13 to +158 °F] (non-freezing)
	Humidity	85 % or less (non-condensing)
	Altitude	Up to 3,000 m (10,000 ft.) above sea level
	Surrounding atmosphere	No corrosive gas, dust, water or oil.

## 13-3 Regulations and standards

### ■ UL Standards, CSA Standards

This product is recognized by UL under the UL and CSA Standards.

The driver is not provided with the electronic motor overload protection and the motor overtemperature protection specified in UL and CSA Standards.

### ■ CE Marking/UKCA Marking

This product is affixed with the marks under the following directives/regulations.

#### ● EU EMC Directive/UK EMC Regulation

Refer to "6-6 Compliance with the EMC Directive/Regulations" on p.20 for details about conformity.

#### ● EU RoHS Directive/UK RoHS Regulation

This product does not contain the substances exceeding the restriction values.



- Unauthorized reproduction or copying of all or part of this Manual is prohibited.  
If a new copy is required to replace an original manual that has been damaged or lost, please contact your nearest Oriental Motor sales office.
- Oriental Motor shall not be liable whatsoever for any problems relating to industrial property rights arising from use of any information, circuit, equipment or device provided or referenced in this manual.
- Characteristics, specifications and dimensions are subject to change without notice.
- While we make every effort to offer accurate information in the manual, we welcome your input. Should you find unclear descriptions, errors or omissions, please contact your nearest Oriental Motor sales office.
- **Orientalmotor**, **αSTEP**, and ABZO sensor are registered trademarks or trademarks of Oriental Motor Co., Ltd., in Japan and other countries.  
Modbus is a registered trademark of the Schneider Automation Inc.  
Other product names and company names mentioned in this manual may be registered trademarks or trademarks of their respective companies and are hereby acknowledged. The third-party products mentioned in this manual are recommended products, and references to their names shall not be construed as any form of performance guarantee. Oriental Motor is not liable whatsoever for the performance of these third-party products.

© Copyright ORIENTAL MOTOR CO., LTD. 2021

Published in December 2025

- Please contact your nearest Oriental Motor office for further information.

ORIENTAL MOTOR U.S.A. CORP.  
Technical Support Tel:800-468-3982  
8:30am EST to 5:00pm PST (M-F)

ORIENTAL MOTOR (EUROPA) GmbH  
Schiessstraße 44, 40549 Düsseldorf, Germany  
Technical Support Tel:00 800/22 55 66 22

ORIENTAL MOTOR (UK) LTD.  
Blythe Valley Business Park,  
Central Blvd Blythe Valley Park,  
Solihull B90 8AG, United Kingdom  
Tel:+44-1926-671220

ORIENTAL MOTOR (FRANCE) SARL  
Tel:+33-1 47 86 97 50

ORIENTAL MOTOR ITALIA s.r.l.  
Tel:+39-02-93906347

ORIENTAL MOTOR ASIA PACIFIC PTE. LTD.  
Singapore  
Tel:1800-842-0280

ORIENTAL MOTOR (MALAYSIA) SDN. BHD.  
Tel:1800-806-161

ORIENTAL MOTOR (THAILAND) CO., LTD.  
Tel:1800-888-881

ORIENTAL MOTOR (INDIA) PVT. LTD.  
Tel:1800-120-1995 (For English)  
1800-121-4149 (For Hindi)

TAIWAN ORIENTAL MOTOR CO., LTD.  
Tel:0800-060708

SHANGHAI ORIENTAL MOTOR CO., LTD.  
Tel:400-820-6516

INA ORIENTAL MOTOR CO., LTD.  
Korea  
Tel:080-777-2042

ORIENTAL MOTOR CO., LTD.  
4-8-1 Higashiueno, Taito-ku, Tokyo  
110-8536 Japan  
Tel:+81-3-6744-0361  
[www.orientalmotor.co.jp/ja](http://www.orientalmotor.co.jp/ja)