

αSTEP

AZ Series / Motorized Actuator

equipped with AZ Series

mini Driver

EtherNet/IP™ Compatible

USER MANUAL

Introduction

Hardware

Implicit communication

Parameter ID lists

Troubleshooting

Reference materials

Thank you for purchasing an Oriental Motor product.

This Manual describes product handling procedures and safety precautions.

- Please read it thoroughly to ensure safe operation.
- Always keep the manual where it is readily available.

1 Introduction

| | | |
|-----|-----------------------------------|----|
| 1 | Before using the product..... | 6 |
| 2 | Operating manuals | 7 |
| 2-1 | Related operating manuals..... | 7 |
| 2-2 | How to use operating manuals..... | 7 |
| 3 | Overview of the product..... | 9 |
| 4 | Safety precautions | 10 |
| 5 | Precautions for use | 12 |

2 Hardware

| | | |
|-----|--|----|
| 1 | System configuration | 16 |
| 2 | Preparation..... | 17 |
| 2-1 | Checking the product..... | 17 |
| 2-2 | How to identify the product model | 17 |
| 2-3 | Products possible to combine | 17 |
| 2-4 | Information about nameplate | 18 |
| 2-5 | Names and functions of parts | 18 |
| 2-6 | Indication of LEDs..... | 19 |
| 3 | Installation..... | 21 |
| 3-1 | Installation location | 21 |
| 3-2 | Installation method..... | 21 |
| 4 | Connection | 23 |
| 4-1 | Connection example | 23 |
| 4-2 | Connecting the main power supply and the control power supply (CN1)..... | 24 |
| 4-3 | Connecting the EtherNet/IP cable (CN3, CN4) | 26 |
| 4-4 | Connecting the USB cable..... | 26 |
| 4-5 | Connecting input signals (CN5)..... | 26 |
| 4-6 | Noise elimination measures..... | 27 |
| 4-7 | Conformity to EMC Directive/Regulations | 28 |
| 5 | Setting of IP address..... | 30 |
| 5-1 | Setting method of IP address..... | 30 |
| 5-2 | When using the IP address setting switch..... | 30 |
| 5-3 | When setting with parameters | 31 |
| 5-4 | When setting with DHCP server..... | 32 |
| 6 | Inspection and maintenance | 33 |
| 6-1 | Inspection..... | 33 |
| 6-2 | Warranty..... | 33 |
| 6-3 | Disposal | 33 |
| 7 | Cable..... | 34 |
| 7-1 | Connection cables (For cable type)..... | 34 |
| 7-2 | Connection cables (For connector type)..... | 37 |
| 7-3 | Power supply cable | 38 |

3 Implicit communication

| | | |
|-----|--|----|
| 1 | Flow of Implicit communication..... | 40 |
| 2 | Guidance | 41 |
| 3 | Communication specifications | 44 |
| 4 | Implicit message..... | 45 |
| 4-1 | Implicit message format..... | 45 |
| 4-2 | Input data | 46 |
| 4-3 | Output data | 49 |
| 4-4 | Processing order of Implicit communication | 53 |
| 4-5 | Data writing | 54 |
| 4-6 | Data reading | 55 |
| 5 | Example of execution for operation | 57 |
| 5-1 | Positioning operation..... | 57 |
| 5-2 | Continuous operation..... | 58 |
| 6 | Direct data operation | 59 |
| 6-1 | Overview of direct data operation | 59 |
| 6-2 | Output data and parameters required for direct data operation..... | 60 |
| 6-3 | Operation example | 63 |

4 Parameter ID lists

| | | |
|-----|---|----|
| 1 | Timing for parameter to update..... | 68 |
| 2 | Maintenance commands | 69 |
| 3 | Monitor commands | 70 |
| 4 | Operation data R/W commands | 76 |
| 4-1 | Base address of each operation data number..... | 76 |
| 4-2 | Parameter ID | 78 |
| 4-3 | Setting example | 79 |
| 5 | Operation I/O event R/W commands..... | 80 |
| 5-1 | Base address of operation I/O event..... | 80 |
| 5-2 | Parameter ID for operation I/O event R/W command | 80 |
| 6 | Protect release commands | 81 |
| 7 | Extended operation data setting R/W command | 82 |
| 8 | Parameter R/W commands..... | 83 |
| 8-1 | Driver action simulation setting parameter..... | 83 |
| 8-2 | Base setting parameter | 83 |
| 8-3 | Coordinate parameters..... | 84 |
| 8-4 | Operation parameters..... | 84 |
| 8-5 | Direct data operation parameters | 84 |
| 8-6 | ABZO sensor setting parameters | 85 |
| 8-7 | Mechanism settings parameters..... | 85 |
| 8-8 | Initial coordinate generation & wrap coordinate parameters..... | 85 |

| | | |
|----------|--|-----------|
| 8-9 | JOG/HOME/ZHOME operation information setting parameters..... | 86 |
| 8-10 | Alarm setting parameters..... | 87 |
| 8-11 | Information setting parameters..... | 87 |
| 8-12 | I/O parameters..... | 89 |
| 8-13 | Direct I/O setting parameters..... | 92 |
| 8-14 | Remote I/O setting parameters..... | 92 |
| 8-15 | Virtual input parameters..... | 93 |
| 8-16 | User output setting parameters..... | 94 |
| 8-17 | Driver mode setting parameters..... | 94 |
| 8-18 | EtherNet/IP communication setting parameters..... | 94 |
| 9 | I/O signals assignment list..... | 96 |
| 9-1 | Input signals..... | 96 |
| 9-2 | Output signals..... | 97 |

5 Troubleshooting

| | | |
|----------|--|------------|
| 1 | Detection of communication errors..... | 100 |
| 1-1 | Communication timeout..... | 100 |
| 1-2 | IP address conflict..... | 100 |
| 2 | Alarms..... | 101 |
| 2-1 | Alarm reset..... | 101 |
| 2-2 | Alarm history..... | 101 |
| 2-3 | Generation condition of alarms..... | 101 |
| 2-4 | Alarm list..... | 102 |
| 2-5 | Timing chart..... | 107 |
| 3 | Information..... | 109 |
| 3-1 | Information history..... | 112 |
| 3-2 | Information list..... | 112 |
| 4 | Troubleshooting and remedial actions..... | 115 |

6 Reference materials

| | | |
|----------|---------------------------------------|------------|
| 1 | Timing chart..... | 118 |
| 2 | Specifications..... | 120 |
| 2-1 | Product specifications..... | 120 |
| 2-2 | General specifications..... | 120 |
| 3 | Regulations and standards..... | 121 |

1 Introduction



This part explains the product overview and safety precautions in addition to the types and descriptions about operating manuals.

◆ Table of contents

| | | |
|----------|--|-----------|
| 1 | Before using the product | 6 |
| 2 | Operating manuals | 7 |
| | 2-1 Related operating manuals..... | 7 |
| | 2-2 How to use operating manuals | 7 |
| 3 | Overview of the product..... | 9 |
| 4 | Safety precautions | 10 |
| 5 | Precautions for use..... | 12 |

1 Before using the product

Only qualified personnel of electrical and mechanical engineering should work with the product. Use the product correctly after thoroughly reading the section "4 Safety precautions" on p.10. In addition, be sure to observe the contents described in warning, caution, and note in this manual. The product described in this document has been designed and manufactured to be incorporated in general industrial equipment. Do not use for any other purpose. Oriental Motor Co., Ltd. is not responsible for any compensation for damage caused through failure to observe this warning.

2 Operating manuals

2-1 Related operating manuals

For operating manuals, download from Oriental Motor Website Download Page or contact your nearest Oriental Motor sales office.

- **AZ** Series / Motorized Actuator equipped with **AZ** Series mini Driver EtherNet/IP Compatible USER MANUAL (this document)
- **AZ** Series / Motorized Actuator equipped with **AZ** Series OPERATING MANUAL Function Edition

Read the following operating manuals for motors and motorized actuators.

- OPERATING MANUAL Motor Edition
- OPERATING MANUAL Actuator Edition
- Motorized Actuator OPERATING MANUAL Function Setting Edition

2-2 How to use operating manuals

To use the product, read this manual together with the **AZ** Series OPERATING MANUAL Function Edition. This manual describes contents specific to the mini Driver EtherNet/IP compatible, and the **AZ** Series OPERATING MANUAL Function Edition describes contents common to the **AZ** Series products. Refer to the **AZ** Series OPERATING MANUAL Function Edition for the contents not included in this manual.

Reference destinations are indicated according to the flow of use.

■ How to read reference destinations

The title name of the operating manual is described in the reference destination.



The title number described in the reference destination may be changed. Use the title name when checking the reference destination.

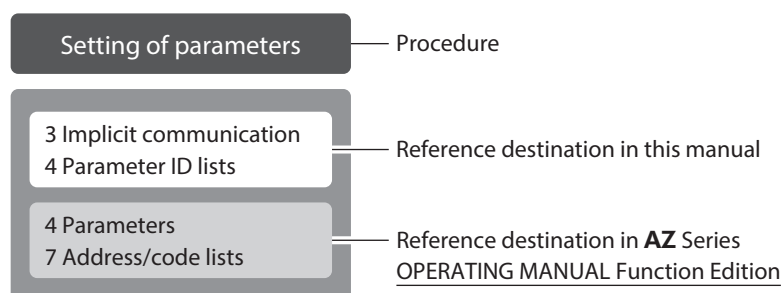

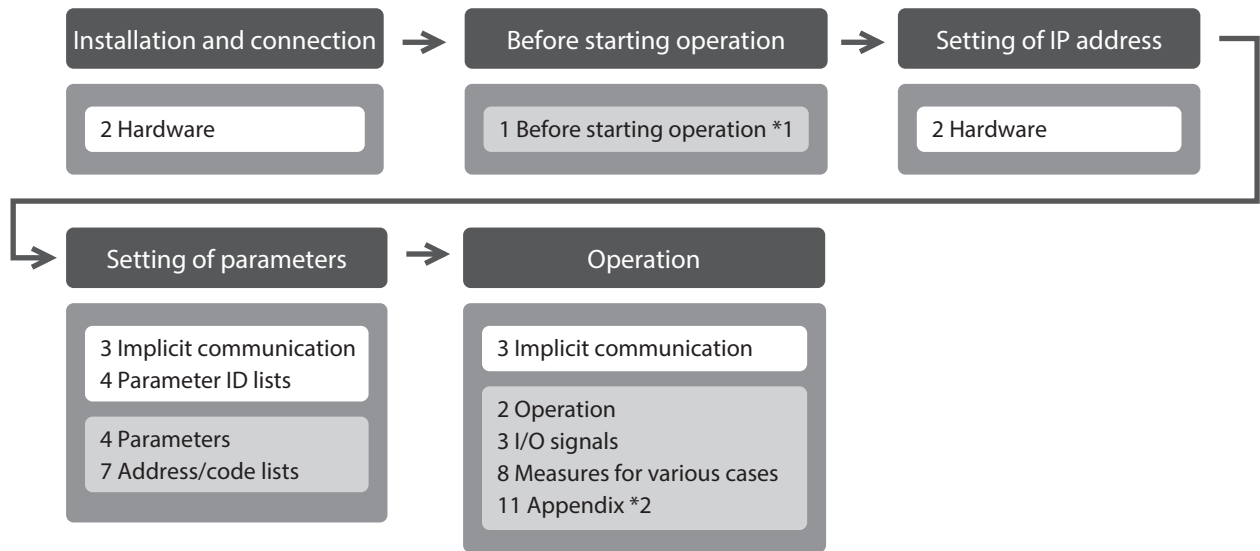

*1 When a motorized actuator is used, the following contents cannot be operated via EtherNet/IP. Use the support software **MEXE02**.

- Copying the fixed value (parameter) of the ABZO sensor to driver
- Creation of recovery data file and method of recovery

*2 Refer to this manual for "LEDs of the driver." (⇒ p.19)

■ Description of power supplies

This manual describes contents when a main power supply and a control power supply are used.

The mini Driver can also be used with a main power supply only. When using it with only the main power supply, replace "main power supply and control power supply" or "control power supply" with "main power supply" to read this manual.

3 Overview of the product

The **AZ** Series mini Driver EtherNet/IP compatible is the dedicated driver for the **AZ** Series products.

■ Compact and light weight

Compact and lightweight are achieved, offering the dimensions of 69 mm×56 mm×30 mm (2.72 in.×2.2 in.×1.18 in.) and the mass of 0.11 kg (0.24 lb.).

■ Compatible with EtherNet/IP

Direct data operation can be started, and operation data and parameters can be set via Implicit communication (periodic communication) of EtherNet/IP.

■ Setting methods of operation data and parameters

Operation data and parameters can be set via EtherNet/IP or using the **MEXE02** software. This manual describes how to set operation data and parameters via EtherNet/IP.

■ Equipped with direct data operation function

Direct data operation is a function to start operation at the same time as rewriting of the data. It can be used when the setting of the operation data is changed frequently, such as changing the speed or travel amount according to a load.





■ Providing the EDS File

The EDS file (Electronic Data Sheets file) is a file that describes the specific information of the EtherNet/IP compatible products. Importing the EDS file to the setting tool of the scanner can perform the settings of EtherNet/IP before the driver is delivered to you.

For details, contact your nearest Oriental Motor sales office.

4 Safety precautions

The precautions described below are intended to ensure the safe and correct use of the product, and to prevent the user and other personnel from exposure to the risk of injury. Use the product only after carefully reading and fully understanding these instructions.

| | |
|--|--|
|  WARNING | Handling the product without observing the instructions that accompany a "WARNING" symbol may result in serious injury or death. |
|  CAUTION | Handling the product without observing the instructions that accompany a "CAUTION" symbol may result in injury or property damage. |
|  | The items under this heading contain important handling instructions that the user should observe to ensure safe use of the product. |
|  | The items under this heading contain related information and contents to gain a further understanding of the text in this manual. |

 **WARNING**

General

- Do not use the product in explosive or corrosive environments, in the presence of flammable gases, in places subjected to splashing water, or near combustibles. Doing so may result in fire, electric shock, or injury.
- Assign qualified personnel to the task of installing, wiring, operating/controlling, inspecting and troubleshooting the product. Handling by unqualified personnel may result in fire, electric shock, injury, or damage to equipment.
- Do not transport, install, connect or inspect the product while the power is supplied. Doing so may result in electric shock.
- Do not touch the driver while the power is supplied. Doing so may result in fire or electric shock.
- When an alarm of the driver is generated (any of the driver's protective functions is triggered), remove the cause before resetting the alarm (protective function). Continuing the operation without removing the cause of the problem may cause malfunction of the motor and the driver, leading to injury or damage to equipment.

Installation

- Install the driver in an enclosure. Failure to do so may result in electric shock or injury.

Connection

- Observe the product specifications for the power supply voltage of the driver. Failure to do so may result in fire or electric shock.
- Connect the product securely according to the connection diagram. Failure to do so may result in fire or electric shock.
- Do not forcibly bend, pull, or pinch the connection cable. Doing so may result in fire or electric shock.

Operation

- Turn off the main power supply and the control power supply in the event of a power failure. Failure to do so may result in injury or damage to equipment.
- Do not remove the motor excitation during operation. Doing so may cause the motor to stop and lose the holding force, resulting in injury or damage to equipment.

Repair, disassembly, and modification

- Do not disassemble or modify the driver. Doing so may result in injury or damage to equipment.

 **CAUTION****General**

- Do not use the driver beyond the specifications. Doing so may result in electric shock, injury, or damage to equipment.
- Keep your fingers and objects out of the openings in the driver. Failure to do so may result in fire, electrical shock, or injury.
- Do not touch the driver during operation or immediately after stopping. Doing so may result in a skin burn(s).
- Do not forcibly bend or pull the cable that is connected to the driver. Doing so may cause damage to the product.

Installation

- Keep the area around the driver free of combustible materials. Failure to do so may result in fire or a skin burn(s).
- Do not leave anything around the driver that would obstruct ventilation. Doing so may result in damage to equipment.

Operation

- Use a motor and a driver only in the specified combination. An incorrect combination may cause a fire.
- Take measures against static electricity when operating the switches of the driver. Failure to do so may result in the driver malfunction or damage to equipment.
- Provide an emergency-stop device or emergency-stop circuit external to the equipment so that the entire equipment will operate safely in the event of a system failure or malfunction. Failure to do so may result in injury.
- When moving the moving part manually, put the motor into a non-excitation state. Continuing the work while the motor is in an excitation state may result in injury.
- For the main power supply and the control power supply, use a DC power supply with reinforced insulation on its primary and secondary sides. Failure to do so may result in electric shock.
- When an abnormal condition has occurred, immediately stop operation to turn off the main power supply and control power supply. Failure to do so may result in fire, electrical shock or injury.

5 Precautions for use

This chapter explains restrictions and requirements the user should consider when using the product.

- **Always use Oriental Motor cables to connect a motor and a driver.**

Refer to the cable models on p.34.

- **When conducting the insulation resistance measurement or the dielectric strength test, be sure to separate the connection between the motor and the driver.**

Conducting the insulation resistance measurement or the dielectric strength test with the motor and driver connected may result in damage to the product.

- **Note when connecting a main power supply and a control power supply in a state of grounding the positive side**

The USB connector on the driver is not electrically insulated. When grounding the positive terminals of a main power supply and a control power supply, do not connect any equipment (PC, etc.) whose negative terminal is grounded. Doing so may cause the driver and this equipment to short, damaging both. When connecting, do not ground equipment.

- **Saving data to the non-volatile memory**

Do not turn off the main power supply and control power supply while writing the data to the non-volatile memory, and also do not turn off for 5 seconds after the completion of writing the data. Doing so may abort writing the data and cause an alarm of EEPROM error to generate. The non-volatile memory can be rewritten approximately 100,000 times.

- **Noise elimination measures**

Refer to p.27 for noise elimination measures.

- **Regeneration**

When operating a large load inertia at a high speed, the regenerative energy generated may increase the voltage of the main power supply, causing an alarm of Overvoltage to generate. To prevent damage to the driver, reconsider the operating conditions so that regenerative voltage does not generate.

■ Notes when the connection cable is used

Note the following points when an Oriental Motor cable is used.

- **When inserting the connector**

Hold the connector main body, and insert it in straight securely. Inserting the connector in an inclined state may result in damage to terminals or a connection failure.

- **When pulling out the connector**

Pull out the connector in straight while releasing the lock part of the connector. Pulling out the connector with holding the cable may result in damage to the connector.

- **Bending radius of cable**

- Use the cable in a condition where the bending radius of the cable is as follows.

Cable type: More than 6 times the cable diameter

Connector type: More than 2.8 times the cable diameter

- Do not bend the lead wires part or secure with a clamp, etc. Doing so may result in damage to the connector.

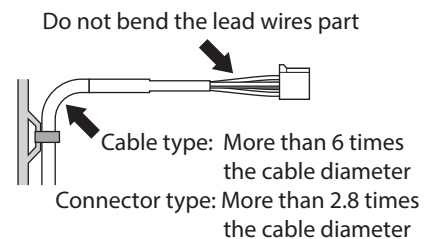

● **How to fix the cable**

Fix the cable at two places near the connectors as shown in the figure or fix it with a wide clamp to take measures to prevent stress from being applied to the connectors.

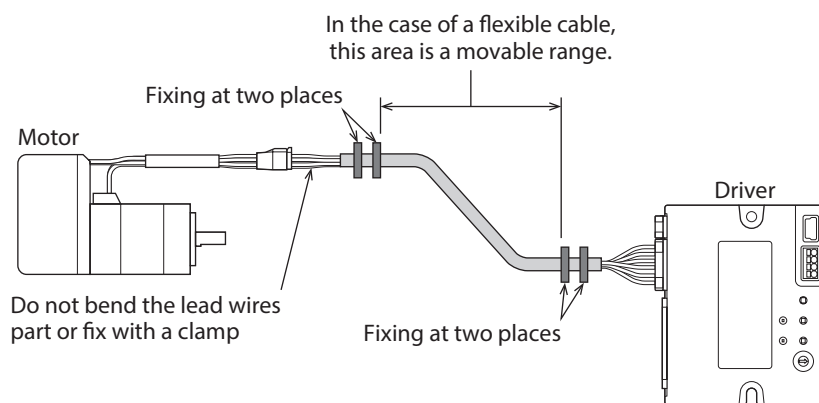

2 Hardware

This part explains names and functions of each part of the driver, installation and connection methods, and so on.

◆Table of contents

| | | | | |
|----------|--|-----------|--|--|
| 1 | System configuration..... | 16 | | |
| 2 | Preparation..... | 17 | | |
| 2-1 | Checking the product..... | 17 | | |
| 2-2 | How to identify the product model..... | 17 | | |
| 2-3 | Products possible to combine..... | 17 | | |
| 2-4 | Information about nameplate..... | 18 | | |
| 2-5 | Names and functions of parts..... | 18 | | |
| 2-6 | Indication of LEDs..... | 19 | | |
| 3 | Installation..... | 21 | | |
| 3-1 | Installation location..... | 21 | | |
| 3-2 | Installation method..... | 21 | | |
| 4 | Connection..... | 23 | | |
| 4-1 | Connection example..... | 23 | | |
| 4-2 | Connecting the main power supply and the control power supply (CN1)..... | 24 | | |
| 4-3 | Connecting the EtherNet/IP cable (CN3, CN4)..... | 26 | | |
| 4-4 | Connecting the USB cable..... | 26 | | |
| 4-5 | Connecting input signals (CN5)..... | 26 | | |
| 4-6 | Noise elimination measures..... | 27 | | |
| 4-7 | Conformity to EMC Directive/Regulations..... | 28 | | |
| 5 | Setting of IP address..... | 30 | | |
| 5-1 | Setting method of IP address..... | 30 | | |
| 5-2 | When using the IP address setting switch..... | 30 | | |
| 5-3 | When setting with parameters..... | 31 | | |
| 5-4 | When setting with DHCP server..... | 32 | | |
| 6 | Inspection and maintenance..... | 33 | | |
| 6-1 | Inspection..... | 33 | | |
| 6-2 | Warranty..... | 33 | | |
| 6-3 | Disposal..... | 33 | | |
| 7 | Cable..... | 34 | | |
| 7-1 | Connection cables (For cable type)..... | 34 | | |
| 7-2 | Connection cables (For connector type)..... | 37 | | |
| 7-3 | Power supply cable..... | 38 | | |

1 System configuration

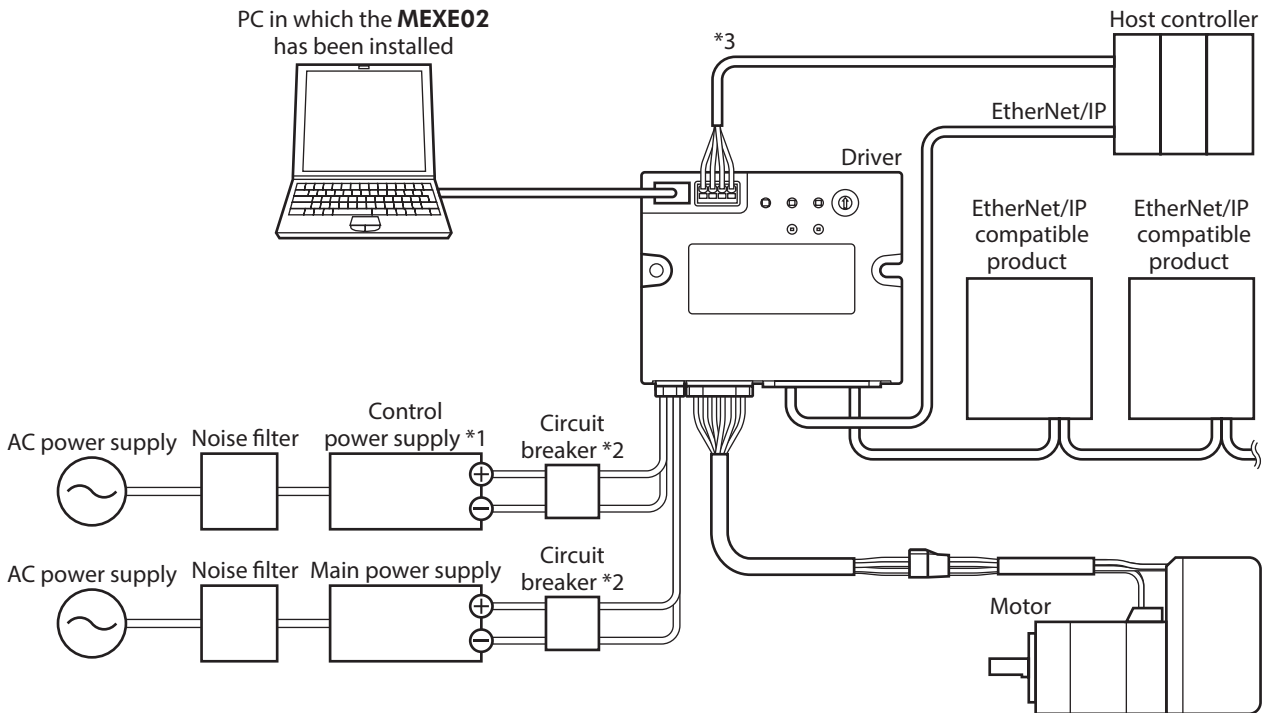

- *1 Connecting the control power supply allows you to continue monitoring even if the main power supply is shut off. Connect it as necessary.
- *2 It is recommended that a circuit breaker or a circuit protector is connected because incorrect wiring of the power supply may cause the internal input circuit to short-circuit.
- *3 Connect when using direct inputs or sensors.

2 Preparation

This chapter explains the items you should check, as well as names and functions of each part.

2-1 Checking the product

Verify that the items listed below are included. Report any missing or damaged items to the Oriental Motor sales office from which you purchased the product.

- Driver 1 unit
- Instructions and Precautions for Safe Use 1 copy

2-2 How to identify the product model

Check the driver model against the model shown on the nameplate. Refer to "2-4 Information about nameplate" on p.18 for how to identify the nameplate.

AZD - K R EP
 1 2 3 4

| | | |
|---|--------------------|------------------------------|
| 1 | Series | AZD: AZ Series driver |
| 2 | Power supply input | K: DC power input |
| 3 | Driver figure | R: Compact |
| 4 | Type | EP: EtherNet/IP |

2-3 Products possible to combine

Products with which the driver can be combined are listed below. Check the model name of the product with the nameplate.

| Power supply type | Product type | Applicable Series | Model name representing Series name *1 | Example of model name |
|-------------------|--------------------|-----------------------|--|---------------------------------------|
| DC power input | Stepping Motor | AZ Series | AZM | AZM46AK |
| | Motorized actuator | EAC Series *2 | EACM | EACM2E05AZAK |
| | | EAS Series *2 | EASM | EASM4NXD005AZAK |
| | | EZS Series *2 | EZSM | EZSM6D005AZAK |
| | | DR Series | DR | DR28G2.5B03-AZAKU |
| | | DRS2 Series | DRSM | DRSM60-05A4AZAK |
| | | DGII Series *2 | DGM DGB | DGM85R-AZAK DGB85R12-AZAKR |
| | | EH Series *2 | EH | EH4-AZAKH |
| | | L Series *2 | LM | LM4F150AZAK-1 |

*1 The driver described in this manual can be combined with products that begin with these model names.

*2 For these motorized actuators, the equipped motors have been evaluated to affix the CE Marking. The model name of the equipped motor can be checked as follows..

EAC Series, EAS Series, EZS Series: Check with the motor nameplate.

DGII Series, EH Series, L Series: Check with "P/N (Motor P/N)" described on the actuator nameplate.

2-4 Information about nameplate

The figure shows an example.

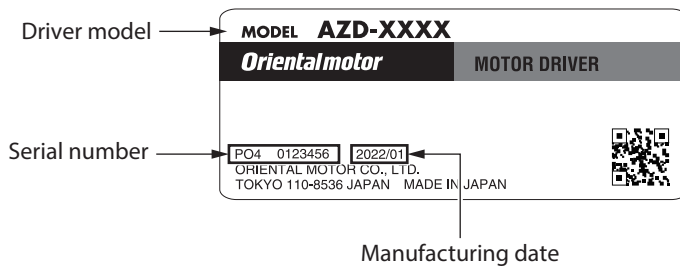

2-5 Names and functions of parts

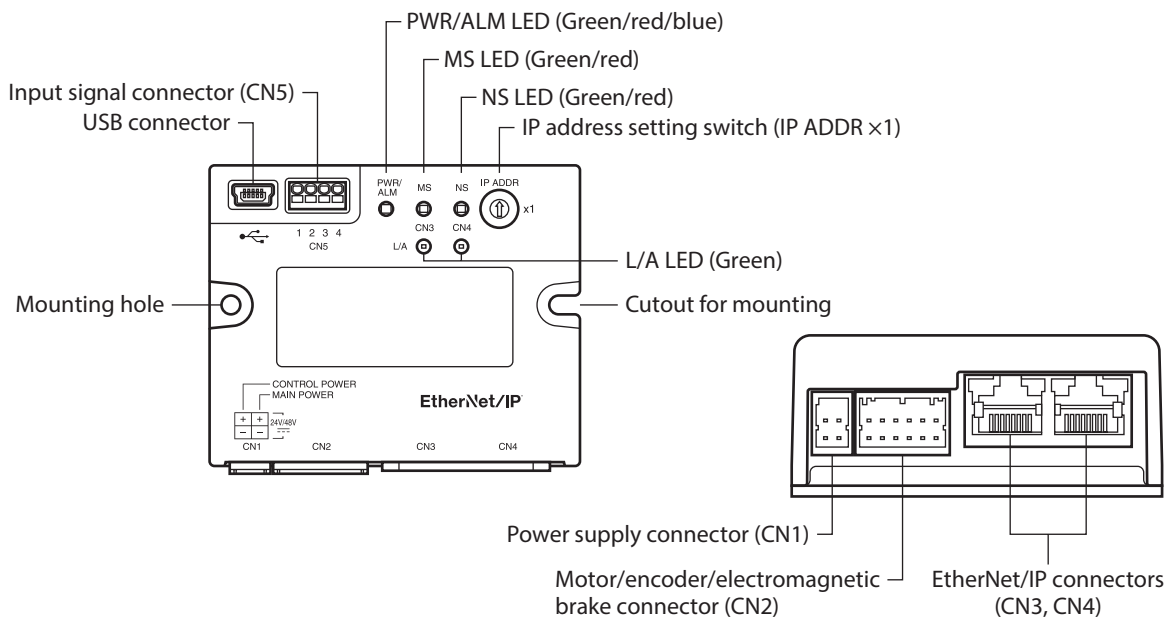

| Type | Name | Sign | Description |
|-----------|---|---|--|
| LED | PWR/ALM LED (Green/Red/Blue) | PWR/ALM | This LED indicates the status of the driver. |
| | MS LED (Green/Red) | MS | This LED indicates the status of the driver. |
| | NS LED (Green/Red) | NS | This LED indicates the communication status of EtherNet/IP. |
| | L/A LED (Green) | L/A | This LED indicates the LINK/ACT status of EtherNet/IP. |
| Switch | IP address setting switch | IP ADDR ×1 | Sets the IP address. Factory setting: 0 (×1: 0) |
| Connector | Power supply connector (CN1) | + , - | Connects a main power supply and a control power supply. |
| | Motor/encoder/electromagnetic brake connector (CN2) | - | Connects the motor, the encoder, and the electromagnetic brake. |
| | USB connector |  | Connects a PC in which the MEXE02 software has been installed. (USB2.0 mini-B port) |
| | EtherNet/IP connectors (CN3, CN4) | - | Connects the EtherNet/IP cable. |
| | Input signals connector (CN5) | - | Connects when using direct inputs or sensors. |

2-6 Indication of LEDs

■ PWR/ALM LED

This LED indicates the status of the driver.

| LED status | Description |
|---|---|
| No light | The main power supply and the control power supply are not turned on. |
| Green light | The main power supply and/or the control power supply are turned on. |
| Blinking red | An alarm is being generated. The alarm message generated can be checked by counting the number of times the LED blinks. The LED is lit in green when the alarm is reset. |
| Blinking blue | <ul style="list-style-type: none"> Information is being generated. The LED is lit in green when the information is cleared. Remote operation is being executed with the MEXE02 software. The LED is lit in green when remote operation is completed. |
| Repeating "Green → Red → Simultaneously lit * → No light" | This is the driver simulation mode. |

* Green and red colors may overlap and it may be visible to orange.

■ MS LED

This LED indicates the status of the driver.

| LED status | | Description |
|----------------------|----------|--|
| Green | Red | |
| No light | No light | The main power supply and the control power supply of the driver are not turned on. |
| Blinking | No light | The communication setting of EtherNet/IP is invalid. |
| Light | No light | The driver operates properly. |
| No light | Blinking | <ul style="list-style-type: none"> An alarm that can be reset with EtherNet/IP or the MEXE02 software was generated. The setting of an IP address is duplicated in the same system. |
| No light | Light | An alarm that cannot be reset with EtherNet/IP or the MEXE02 software was generated. |
| Blinking alternately | | Self-diagnosis when turning on the power is executing. |

The blinking state of the LED is as follows.

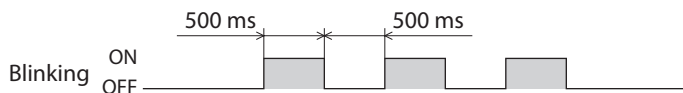

■ NS LED

This LED indicates the communication status of EtherNet/IP.

| LED status | | Description |
|----------------------|----------|---|
| Green | Red | |
| No light | No light | <ul style="list-style-type: none"> This is in an offline state. The main power supply and the control power supply of the driver are not turned on. |
| Blinking | No light | This is in an online state. Connection has not been established with the scanner. |
| Light | No light | This is in an online state. Connection is being established with the scanner. |
| No light | Blinking | Connection timed out with the scanner. |
| No light | Light | The setting of an IP address is duplicated in the same system. |
| Blinking alternately | | Self-diagnosis when turning on the power is executing. |

The blinking state of the LED is as follows.

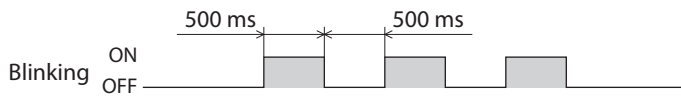

■ L/A LED

This LED indicates the LINK/ACT status of EtherNet/IP.

| LED status | Description |
|------------|--|
| No light | <ul style="list-style-type: none"> This is in an offline state. The frame of EtherNet/IP is not sent and received. |
| Blinking | <ul style="list-style-type: none"> This is in an online state. The frame of EtherNet/IP is sent and received. |
| Light | <ul style="list-style-type: none"> This is in an online state. The frame of EtherNet/IP is not sent and received. |

3 Installation

This chapter explains the installation location and installation method of the driver.

3-1 Installation location

The driver is designed and manufactured to be incorporated in equipment. Install it in a well-ventilated location that provides easy access for inspection. The location must also satisfy the following conditions:

- Inside an enclosure that is installed indoors (provide vent holes)
- Operating ambient temperature: 0 to +50 °C [+32 to 122 °F] (non-freezing)
- Operating ambient humidity: 85 % or less (non-condensing)
- Area free of explosive atmosphere, toxic gas (such as sulfuric gas), or liquid
- Area not exposed to direct sun
- Area free of excessive amount of dust, iron particles or the like
- Area not subject to splashing water (rain, water droplets), oil (oil droplets) or other liquids
- Area free of excessive salt
- Area not subject to continuous vibration or excessive shocks
- Area free of excessive electromagnetic noise (from welders, power machinery, etc.)
- Area free of radioactive materials, magnetic fields or vacuum
- Up to 1,000 m (3,300 ft.) above sea level

3-2 Installation method

The driver can be installed in any direction.

Install the driver onto a flat metal plate offering high heat conductivity [material: aluminum, 150×150×2 mm (5.91×5.91×0.08 in.) or equivalent].

When installing the driver, use the mounting holes and the cutouts for mounting to secure on the metal plate with two screws (M3: not included).

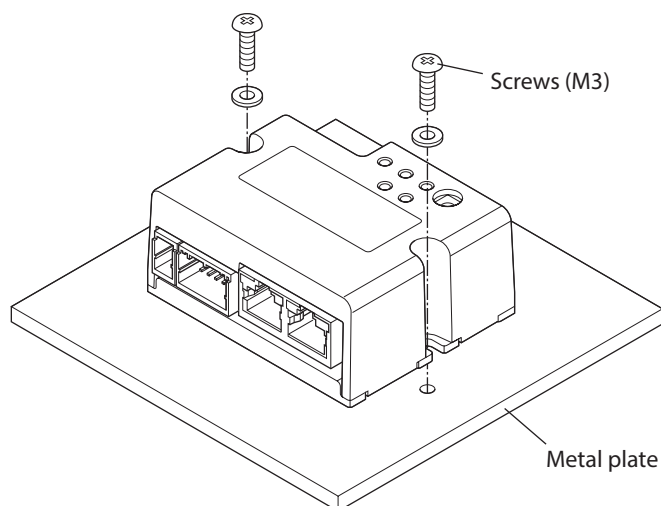

Note

- Install the driver in an enclosure.
- Do not install any equipment that generates a large amount of heat or noise near the driver.
- Do not install the driver underneath a scanner or equipment vulnerable to heat.
- If the ambient temperature of the driver exceeds 50 °C (122 °F), reconsider the ventilation conditions such as providing forced cooling by using fans.

■ **Dimensions [Unit: mm (in.)]**

Mass: 0.11 kg (0.24 lb.)

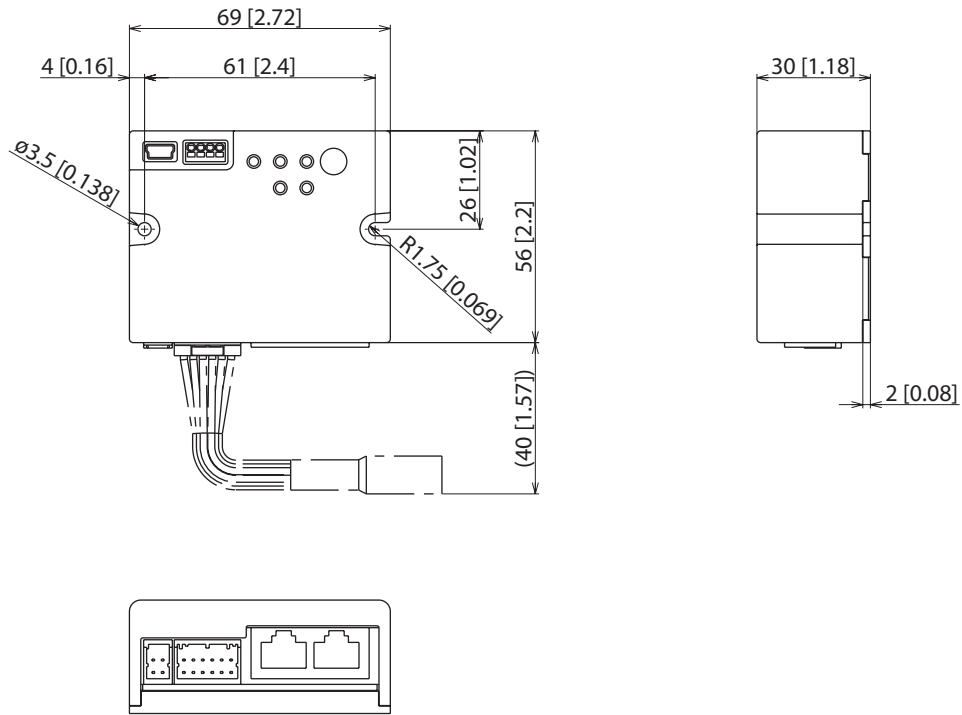

4 Connection

This chapter explains a connection example of a driver and a motor, connection methods of a main power supply and a control power supply, and so on.
It also explains installation and wiring methods to conform to the EMC Directive/Regulations as well as measures against electrical noise.

⚠ WARNING

For protection against electric shock, do not turn on the main power supply and the control power supply until the wiring is completed.

4-1 Connection example

The figure shows an example when the **AZM14** motor is connected.

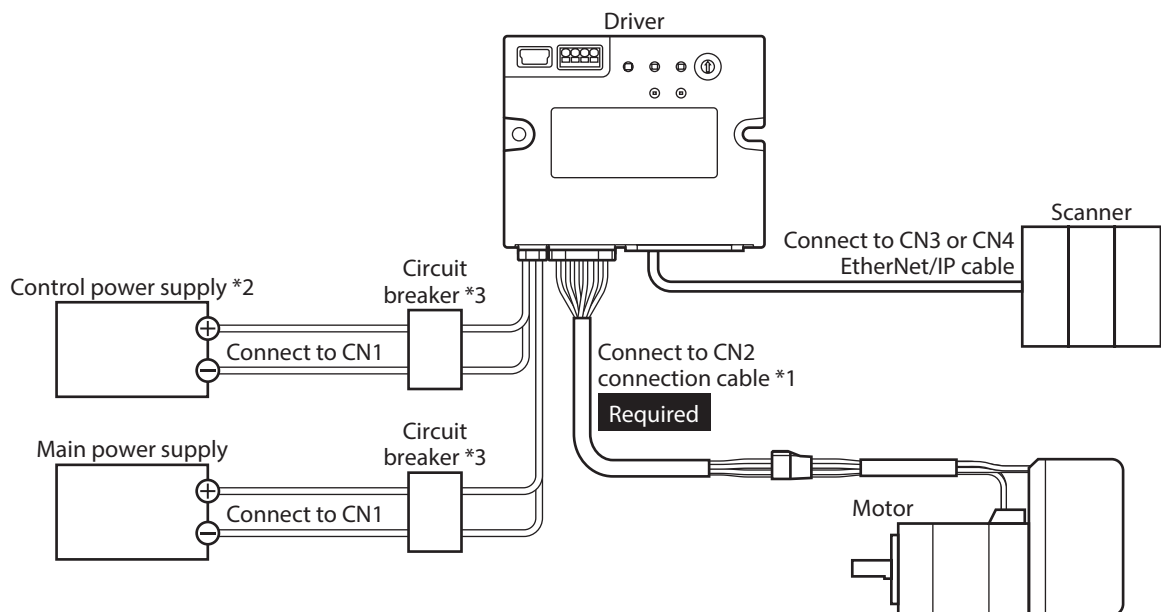

*1 It is an Oriental motor cable. Purchase is required separately.

*2 Connecting the control power supply allows you to continue monitoring even if the main power supply is shut off. Connect it as necessary.

*3 It is recommended that a circuit breaker or a circuit protector is connected because incorrect wiring may cause the internal input circuit to short-circuit.

Note

- Connect the connectors securely. Insecure connections may cause malfunction or damage to the motor or the driver.
- When connecting the cables, secure them so that no load is applied to the connectors. Applying a load to the connector may result in a connection failure, causing the driver to malfunction.
- Keep 10 m (32.8 ft.) or less for the wiring distance between a motor and a driver. Exceeding 10 m (32.8 ft.) in the wiring distance may result in increase of the electrical noise emitted from the driver.
- Keep 2 m (6.6 ft.) or less for the cable length of the main power supply and control power supply cables.

memo

- Before connecting or disconnecting a connector, turn off the main power supply and the control power supply, and check the PWR/ALM LED has been turned off.
- When disconnecting the connector, pull out while pressing the latches on the connector with fingers.

4-2 Connecting the main power supply and the control power supply (CN1)

Connect a main power supply to the CN1 connector.
 Connecting the control power supply allows you to continue monitoring even if the main power supply is shut off.
 Connect it as necessary.

Note Make sure the polarity of the power supply before connecting. Reverse-polarity connection may cause damage to the driver.

■ Applicable connector

| Type | Part number | Applicable lead wire |
|-----------------------|-------------------------------|---|
| Connector housing | 1-1827864-2 (TE Connectivity) | AWG22 (0.34 to 0.37 mm ²) AWG20 (0.51 to 0.53 mm ²) AWG18 (0.85 to 0.87 mm ²) Lead wire insulation outer diameter: ø1.4 to 2.2 mm (ø0.055 to 0.087 in.) Lead wire insulation strip length: 1.7 to 2.3 mm (0.067 to 0.091 in.) |
| Contact | 1827589-2 (TE Connectivity) | |
| Designated crimp tool | 2119142-1 (TE Connectivity) | |

■ Pin assignment

The figure shows the view from the insertion side of contacts.

| Pin No. | Name | Description |
|---------|----------------------|---------------------------------|
| A1 | GND | Ground for control power supply |
| A2 | GND | Ground for main power supply |
| B1 | Control power supply | +24 VDC / +48 VDC |
| B2 | Main power supply | +24 VDC / +48 VDC |

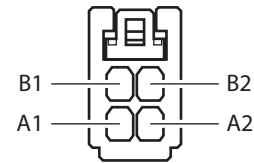

memo A1 and A2 are not electrically insulated.

■ Voltage specifications

The voltage specifications of power supply input include the rated voltage and the allowable operating voltage.
 The voltage specifications are common for the main power supply and the control power supply.

| | |
|-----------------------------|---|
| Rated voltage | 24 VDC±5 % 48 VDC±5 % |
| Allowable operating voltage | 24 VDC input: 20 to 32 VDC (22.8 to 32 VDC) * 48 VDC input: 40 to 55 VDC |

* The value in parentheses () is the one when the electromagnetic brake motor is connected.

memo Set the "Main power mode" parameter to "0: 24 VDC" or "1: 48 VDC" when the main power supply starts up slowly or the voltage of the main power supply is unstable. (⇒ p.83)

Internal input circuit

The driver can be used with the main power supply and control power supply, or with the main power supply only. When using only the main power supply, the power is supplied from the main power supply to the control power supply circuit inside the driver.

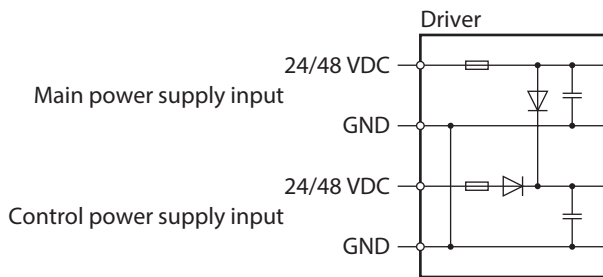

Power supply current capacity

Current capacity for main power supply

The current capacity for the main power supply varies depending on the product combined.

Check the current capacity in reference to the equipped motor model when using the **EAC Series**, **EAS Series**, or **EZS Series**.

| Series | Model | Rated voltage | Power supply current capacity |
|---|--------------|--------------------------|-------------------------------|
| AZ Series EAC Series EAS Series EZS Series | AZM14 | 24 VDC±5 % | 0.4 A or more |
| | AZM15 | | 0.5 A or more |
| | AZM24, AZM26 | | 1.4 A or more |
| | AZM46 | 24 VDC±5 % 48 VDC±5 % | 1.6 A or more |
| | AZM48 | | 2.1 A or more |
| | AZM66 | | 3.7 A or more |
| | AZM69 | | 3.5 A or more |
| DGII Series | DGM60 | 24 VDC±5 % | 1.4 A or more |
| | DGB85 | 24 VDC±5 % 48 VDC±5 % | 1.6 A or more |
| | DGB130 | | 3.7 A or more |
| | DGM85 | | 1.6 A or more |
| | DGM130 | | 3.7 A or more |
| DR Series | DR20 | | 24 VDC±5 % |
| | DR28 | 1.3 A or more | |
| DRS2 Series | DRSM42 | 24 VDC±5 % | 1.5 A or more |
| | DRSM60 | 48 VDC±5 % | 2.6 A or more |
| EH Series | EH3 | 24 VDC±5 % | 0.4 A or more |
| | EH4 | | 1.4 A or more |
| L Series | LM2, LM4 | 24 VDC±5 % 48 VDC±5 % | 3.7 A or more |

Current capacity for control power supply

| Rated voltage | Power supply current capacity | |
|--------------------------|-------------------------------|----------------------------|
| | Without electromagnetic brake | With electromagnetic brake |
| 24 VDC±5 % 48 VDC±5 % | 0.15 A | 0.4 A 30* |

* The **AZM46** type is 0.23 A.

4-3 Connecting the EtherNet/IP cable (CN3, CN4)

Connect the EtherNet/IP cable to the EtherNet/IP connector (CN3, CN4).

Pin assignment

| Signal name | Description |
|-------------|--------------------|
| TXP | Transmitted data + |
| TXN | Transmitted data - |
| RXP | Received data + |
| N.C. | - |
| N.C. | - |
| RXN | Received data - |
| N.C. | - |
| N.C. | - |

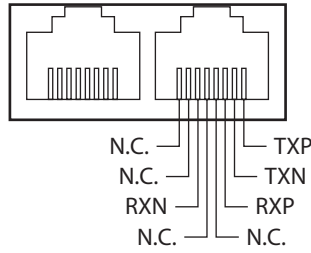

4-4 Connecting the USB cable

Using a USB cable of the following specifications, connect a PC in which the **MEXE02** software has been installed to the USB connector.

| | |
|----------------|---|
| Specifications | USB2.0 (full speed) |
| Cable | Length: 3 m (9.8 ft.) or less Shape: A to mini B |



- Connect the driver and a PC directly using a USB cable.
- In large electrically noisy environments, use the USB cable with a ferrite core or install a ferrite core to the USB cable.

4-5 Connecting input signals (CN5)

Connect when using direct inputs or sensors.

Applicable lead wire and terminal

| | |
|-----------------------------|---|
| Applicable lead wire | <ul style="list-style-type: none"> • AWG26 to 20 (0.14 to 0.5 mm²) • Lead wire strip length: 6 mm (0.24 in.) |
| Applicable ferrule terminal | Without sleeve: 0.25 to 0.5 mm ² With sleeve: 0.25 to 0.34 mm ² |

Pin assignment

| Pin No. | Signal name | Description * |
|---------|-------------|------------------------|
| 1 | IN0+ | Control input 0 (STOP) |
| 2 | IN0- | |
| 3 | IN1+ | Control input 1 (FREE) |
| 4 | IN1- | |

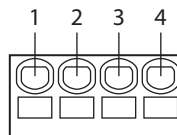

* (): Initial value

■ Connection example with a current sink output circuit

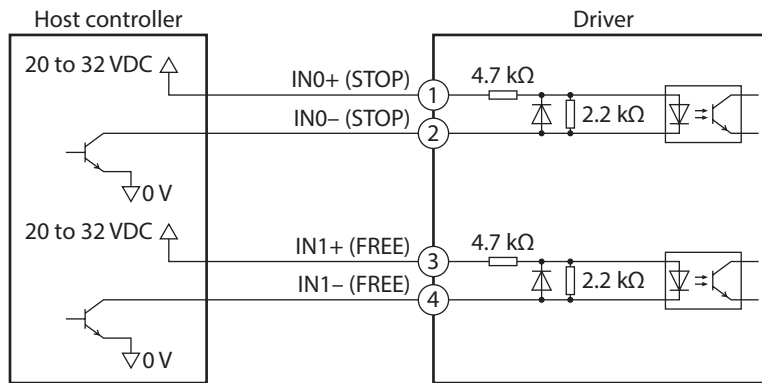

* Values in parentheses () are initial values.

■ Connection example with a current source output circuit

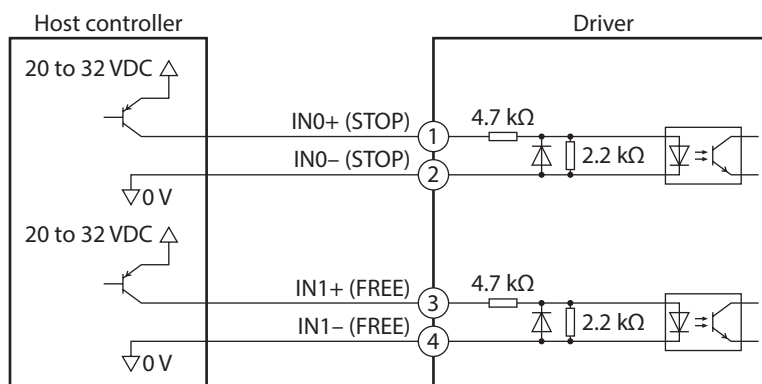

* (): Initial value

4-6 Noise elimination measures

There are two types of electrical noises: One is a noise to invade into the driver from the outside and cause the driver malfunction, and the other is a noise to emit from the driver and cause peripheral equipment malfunction.

For the noise that is invaded from the outside, take measures to prevent the driver malfunction. It is needed to take adequate measures because signal lines are very likely to be affected by the noise.

For the noise that is emitted from the driver, take measures to suppress it.

■ Measures against electrical noise

There are the following three methods mainly to take measures against the electrical noise.

● Noise suppression

- When relays or electromagnetic switches are used, use noise filters or CR circuits to suppress surge generated by them.
- Use an Oriental Motor connection cable when extending the wiring distance between the motor and the driver. Refer to p.34 for the model name. This is effective in suppressing the electrical noise emitted from the motor.
- Cover the driver by a metal plate such as aluminum. This is effective in shielding the electrical noise emitted from the driver.

● **Prevention of noise propagation**

- Connect a noise filter on the input side of the DC power supply.
- Place the power lines, such as the motor and power supply cables, keeping a distance of 200 mm (7.87 in.) or more from the signal lines, and also do not bundle them or wire them in parallel. If a power cable and a signal cable have to cross, cross them at a right angle.
- Use shielded twisted pair cables for power lines and signal lines.
- Keep cables as short as possible without coiling and bundling extra lengths.
- Grounding multiple points will increase effect to block electrical noise because impedance on the grounding points is decreased. However, ground them so that a potential difference does not occur among the grounding points.
- To ground a shielded cable, use a metal cable clamp that can maintain contact with the entire circumference of the shielded cable, and ground as near the product as possible.

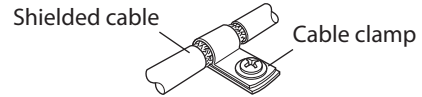

● **Suppression of effect by noise propagation**

- Loop the noise propagated cable around a ferrite core. Doing so will prevent the propagated noise invades into the driver or emits from the driver. The frequency band in which an effect by the ferrite core can be seen is generally 1 MHz or more. Check the frequency characteristics of the ferrite core used. When increasing the effect of noise attenuation by the ferrite core, loop the cable a lot.

4-7 Conformity to EMC Directive/Regulations

Effective measures must be taken against EMI that the motor and driver may give to adjacent control-system equipment, as well as EMS of the motor and driver itself, in order to prevent a serious functional impediment in the machinery. The use of the following installation and wiring methods will enable the motor and driver to be compliant with EMC Directive/Regulations.

Oriental Motor conducts EMC testing on its motors and drivers in accordance with "Example of installation and wiring" on p.29. The user is responsible for ensuring the machine's compliance with EMC, based on the installation and wiring explained below.

⚠ CAUTION

This equipment is not intended for use in residential environments nor for use on a low-voltage public network supplied in residential premises, and it may not provide adequate protection to radio reception interference in such environments.

● **Connecting the main power supply and the control power supply**

Use DC power supplies compliant with EMC Directive/Regulations for the main power supply and the control power supply. Use shielded cables to wire and ground as short as possible. Refer to "Prevention of noise propagation" for how to ground the shielded cable.

● **Ferrite core**

Install the following ferrite core (or equivalent) to the places shown in "Example of installation and wiring" on p.29. Part No.: ZCAT3035-1330 (TDK Corporation)

● **Connecting the motor cable**

Use an Oriental Motor connection cable when extending the wiring distance between the motor and the driver. Refer to p.34 for the model name.

● **Connecting the signal cable**

Refer to "Prevention of noise propagation."

● **How to ground**

- Wires used to ground the motor must be as thick and short as possible so that no potential difference is generated between the grounding points.
- Choose a large, thick and uniformly conductive surface for the grounding point.
- Make sure to ground the Protective Earth Terminal of the motor.

● **Example of installation and wiring**

The figure shows an example when the cable type electromagnetic brake motor is used.

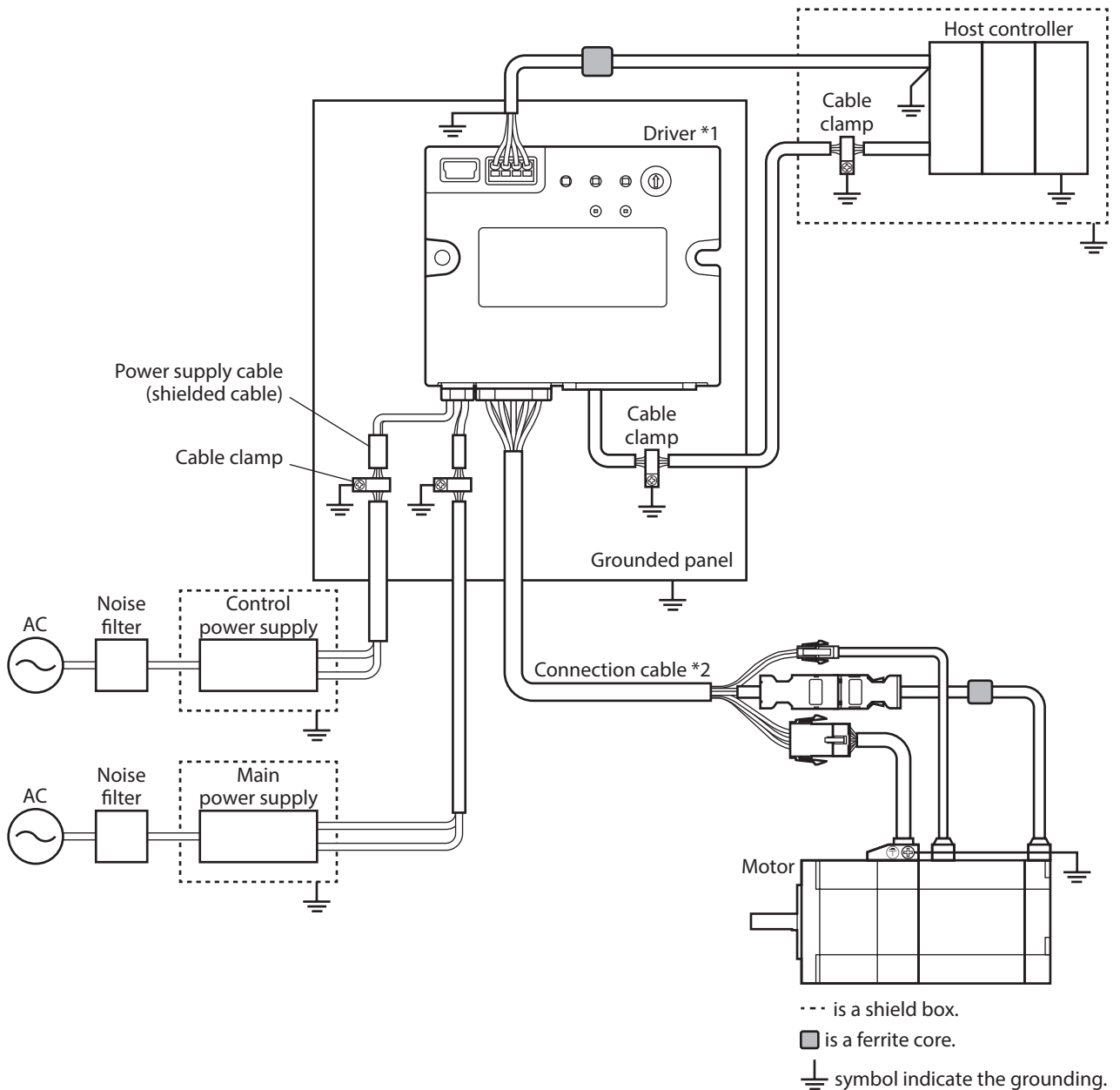

*1 The driver is grounded by making the heat sink contact directly with the grounded panel.

*2 An Oriental Motor cable is used.

Note

- The driver uses components that are sensitive to static electricity. Take measures against static electricity since static electricity may cause the driver to malfunction or suffer damage.
- When connecting the following products, cover the motor cable with a shielded braided sleeving. Use the cable clamps to ground both ends of the shielded braided sleeving.
 - **AZ Series: AZM14, AZM15, AZM24, AZM26**
 - **EAC Series: EACM2**
 - **EAS Series: EASM2**
 - **DR Series: DR20, DR28**
 - **DGII Series: DGM60**
 - **EH Series: EH3, EH4**

5 Setting of IP address

The IP address, subnet mask, and default gateway are configured respectively as follows.

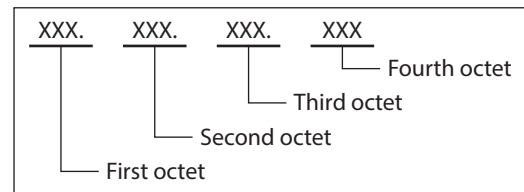

5-1 Setting method of IP address

The following three methods can be used to set the IP address, subnet mask, and default gateway.

| Setting method | Set item | | Specific setting method | | |
|---------------------------|---------------------------|-----------------------------------|--|---------------|-----------------|
| | IP address setting switch | "Configuration Control" parameter | IP address | Subnet mask | Default gateway |
| IP address setting switch | 1 to E | 0 * | First octet to third octet: Parameter Fourth octet: IP address setting switch | Parameter | Parameter |
| | F | 0 * | 192.168.1.1 | 255.255.255.0 | 0.0.0.0 |
| Parameter | 0 | 0 | Parameter | Parameter | Parameter |
| DHCP server | 0 | 2 | DHCP server | DHCP server | DHCP server |

* If the IP address setting switch is other than "0," the "Configuration Control" parameter is automatically set to "0: Parameter."

5-2 When using the IP address setting switch

■ Setting of IP address

Set the first octet to third octet with the parameters. Set the fourth octet with the IP address setting switch.

● First octet to third octet

Related parameters

| Parameter name | Description | Setting range | Initial value |
|----------------|--|---------------|---------------|
| IP Address 1 | Sets the first octet of the IP address. | 0 to 255 | 192 |
| IP Address 2 | Sets the second octet of the IP address. | | 168 |
| IP Address 3 | Sets the third octet of the IP address. | | 1 |

● Fourth octet

Set the fourth octet of the IP address using the IP address setting switch (IP ADDR ×1).

The setting range of the IP address setting switch is 1 to 14 (Eh).

The IP address setting switch is hexadecimal. Convert the IP address from decimal to hexadecimal to set.

Factory setting: 0 (Setting of parameter or DHCP server is enabled)

Setting example

| Setting of switch | Value of IP address | Note |
|-------------------|---|---|
| 0 | The setting of the parameter or DHCP server is enabled. | Whether either the parameter or the DHCP server is enabled can be checked with the "Configuration Control" parameter. |
| 1 | XXX.XXX.XXX.1 | The fourth octet is set to "1." |
| E | XXX.XXX.XXX.14 | The fourth octet is set to "14." |
| F | 192.168.1.1 | This value is applied regardless of the setting of the parameter or the DHCP server. |



- When setting the switch, turn on the main power supply and the control power supply again. The new setting is enabled when the main power supply and the control power supply are turned on again.
- When connecting two or more EtherNet/IP compatible products, set so that an IP address is not duplicated. If an IP address is duplicated, a communication error of the "IP address conflict" is detected.

■ Setting of subnet mask and default gateway

Set the subnet mask and default gateway with the parameters.

Related parameters

| Parameter name | Description | Setting range | Initial value |
|-------------------|---|---------------|---------------|
| Network Mask 1 | Sets the first octet of the subnet mask. | 0 to 255 | 255 |
| Network Mask 2 | Sets the second octet of the subnet mask. | | 255 |
| Network Mask 3 | Sets the third octet of the subnet mask. | | 255 |
| Network Mask 4 | Sets the fourth octet of the subnet mask. | | 0 |
| Gateway Address 1 | Sets the first octet of the default gateway. | 0 to 255 | 0 |
| Gateway Address 2 | Sets the second octet of the default gateway. | | 0 |
| Gateway Address 3 | Sets the third octet of the default gateway. | | 0 |
| Gateway Address 4 | Sets the fourth octet of the default gateway. | | 0 |



When the switch is set to "F", the following values are applied regardless of the setting of the parameter or the DHCP server.

- Subnet mask: 255.255.255.0
- Default gateway: 0.0.0.0

5-3 When setting with parameters

Set the IP address setting switch of the driver to "0" and the "Configuration Control" parameter to "0: Parameter." The parameters and the DHCP server cannot be used in combination.

Related parameters

| Parameter name | Description | Setting range | Initial value |
|-----------------------|---|--------------------------------|---------------|
| Configuration Control | Sets how to obtain the IP address. | 0: Parameter 2: DHCP server | 2 |
| IP Address 1 | Sets the first octet of the IP address. | 0 to 255 | 192 |
| IP Address 2 | Sets the second octet of the IP address. | | 168 |
| IP Address 3 | Sets the third octet of the IP address. | | 1 |
| IP Address 4 | Sets the fourth of the IP address. | | 1 |
| Network Mask 1 | Sets the first octet of the subnet mask. | 0 to 255 | 255 |
| Network Mask 2 | Sets the second octet of the subnet mask. | | 255 |
| Network Mask 3 | Sets the third octet of the subnet mask. | | 255 |
| Network Mask 4 | Sets the fourth octet of the subnet mask. | | 0 |
| Gateway Address 1 | Sets the first octet of the default gateway. | 0 to 255 | 0 |
| Gateway Address 2 | Sets the second octet of the default gateway. | | 0 |
| Gateway Address 3 | Sets the third octet of the default gateway. | | 0 |
| Gateway Address 4 | Sets the fourth octet of the default gateway. | | 0 |



When connecting two or more EtherNet/IP compatible products, set so that an IP address is not duplicated. If an IP address is duplicated, a communication error of the "IP address conflict" is detected.

5-4 When setting with DHCP server

The IP address, subnet mask and default gateway are automatically assigned from the DHCP server. Set the IP address setting switch of the driver to "0" and the "Configuration Control" parameter to "2: DHCP server." The parameters and the DHCP server cannot be used in combination.



If the main power supply and the control power supply is shut off, the IP address obtained from the DHCP server is cleared.

Related parameter

| Parameter name | Description | Setting range | Initial value |
|-----------------------|------------------------------------|--------------------------------|---------------|
| Configuration Control | Sets how to obtain the IP address. | 0: Parameter 2: DHCP server | 2 |

6 Inspection and maintenance

6-1 Inspection

It is recommended that periodic inspections are conducted for the items listed below after each operation of the motor. If any failure is found, discontinue any use and contact your nearest office.

■ Inspection item

- Check if the openings in the driver are clogged.
- Check if the installation place of the driver is loose.
- Check if any of the connection parts of the driver is loose.
- Check if dust is deposited on the driver.
- Check if the driver has unusual smells or appearance defects.



The driver uses semiconductor components. Static electricity may damage the semiconductor components of the driver, so be extremely careful when handling them.

6-2 Warranty

Check on the Oriental Motor Website for the product warranty.

6-3 Disposal

Dispose the product correctly in accordance with laws and regulations, or instructions of local governments.

7 Cable

7-1 Connection cables (For cable type)

■ Connection cables/Flexible connection cables (For AZM14, AZM15, AZM24, AZM26)

These cables are used when connecting a motor and a driver.

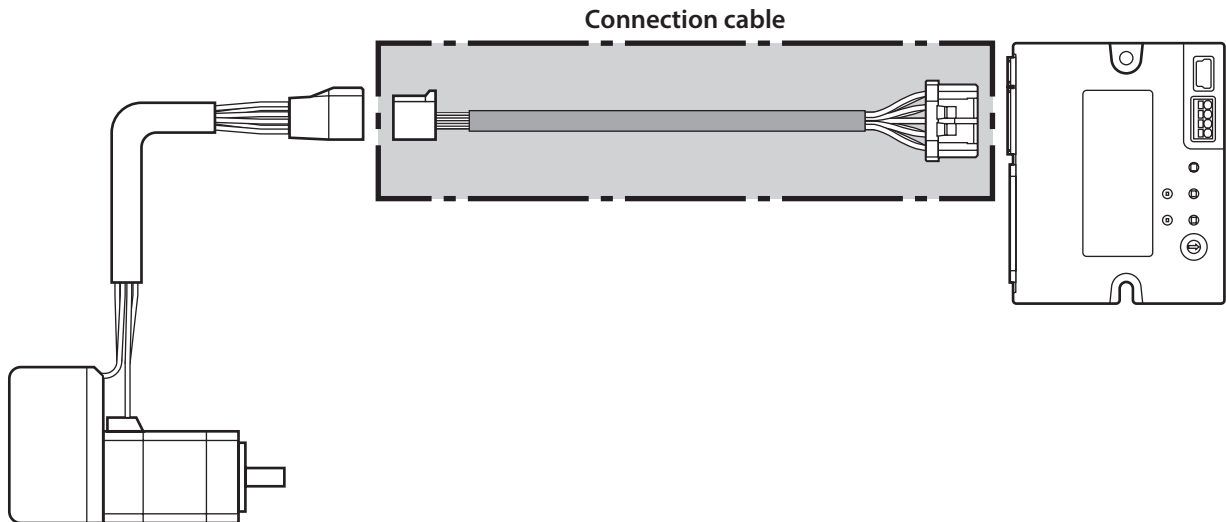

memo When installing the motor on a moving part, use a flexible cable.

● Connection cables For motor/encoder

| Model | Length [m (ft.)] |
|--------------------|---------------------|
| CCM005Z2AAF | 0.5 (1.6) |
| CCM010Z2AAF | 1 (3.3) |
| CCM030Z2AAF | 3 (9.8) |
| CCM050Z2AAF | 5 (16.4) |
| CCM100Z2AAF | 10 (32.8) |

● Flexible connection cables For motor/encoder

| Model | Length [m (ft.)] |
|--------------------|---------------------|
| CCM005Z2AAR | 0.5 (1.6) |
| CCM010Z2AAR | 1 (3.3) |
| CCM030Z2AAR | 3 (9.8) |
| CCM050Z2AAR | 5 (16.4) |
| CCM100Z2AAR | 10 (32.8) |

■ Connection cables/Flexible connection cables (For AZM46, AZM48, AZM66, AZM69)

These cables are used when connecting a motor and a driver.
The figure shows an example when the electromagnetic brake motor is used.

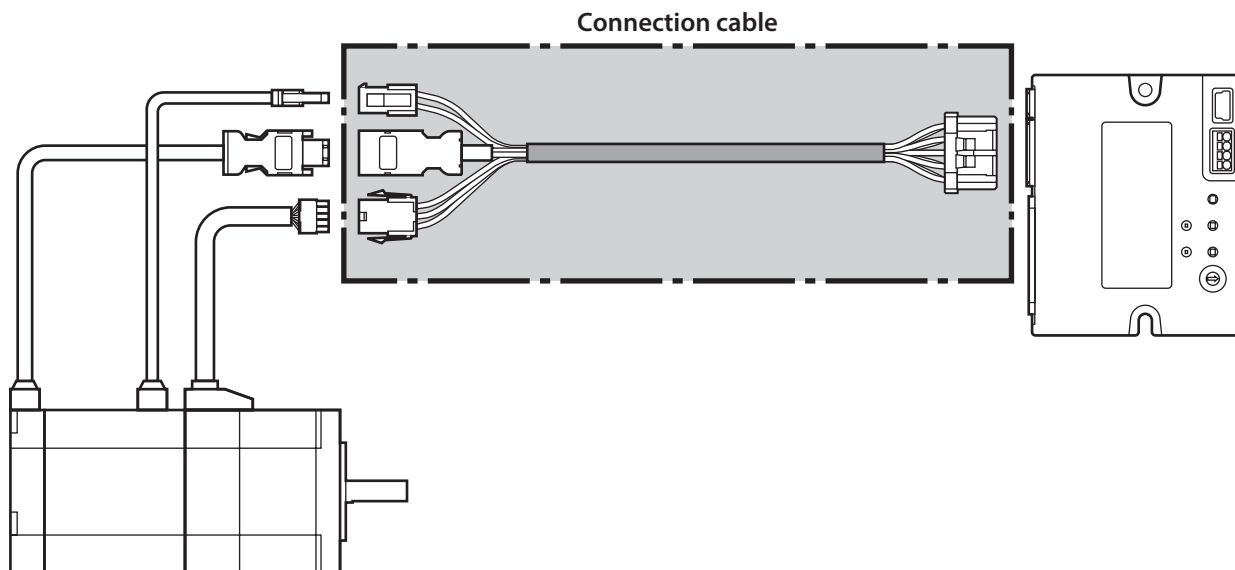

When installing the motor on a moving part, use a flexible cable.

● Connection cables

For motor/encoder

| Model | Length [m (ft.)] |
|-------------|---------------------|
| CCM005Z2ABF | 0.5 (1.6) |
| CCM010Z2ABF | 1 (3.3) |
| CCM030Z2ABF | 3 (9.8) |
| CCM050Z2ABF | 5 (16.4) |
| CCM100Z2ABF | 10 (32.8) |

For motor/encoder/electromagnetic brake

| Model | Length [m (ft.)] |
|-------------|---------------------|
| CCM005Z2ACF | 0.5 (1.6) |
| CCM010Z2ACF | 1 (3.3) |
| CCM030Z2ACF | 3 (9.8) |
| CCM050Z2ACF | 5 (16.4) |
| CCM100Z2ACF | 10 (32.8) |

● Flexible connection cables

For motor/encoder

| Model | Length [m (ft.)] |
|-------------|---------------------|
| CCM005Z2ABR | 0.5 (1.6) |
| CCM010Z2ABR | 1 (3.3) |
| CCM030Z2ABR | 3 (9.8) |
| CCM050Z2ABR | 5 (16.4) |
| CCM100Z2ABR | 10 (32.8) |

For motor/encoder/electromagnetic brake

| Model | Length [m (ft.)] |
|-------------|---------------------|
| CCM005Z2ACR | 0.5 (1.6) |
| CCM010Z2ACR | 1 (3.3) |
| CCM030Z2ACR | 3 (9.8) |
| CCM050Z2ACR | 5 (16.4) |
| CCM100Z2ACR | 10 (32.8) |

■ Extension cables/Flexible extension cables

These cables are used when extending a connection cable (add between the driver and connection cable).
 Use if the length of the connection cable used is not enough when extending the distance between a motor and a driver.
 The extension cables and the flexible extension cables are common to all motors.
 The figure shows an example when the **AZM14** motor is connected.

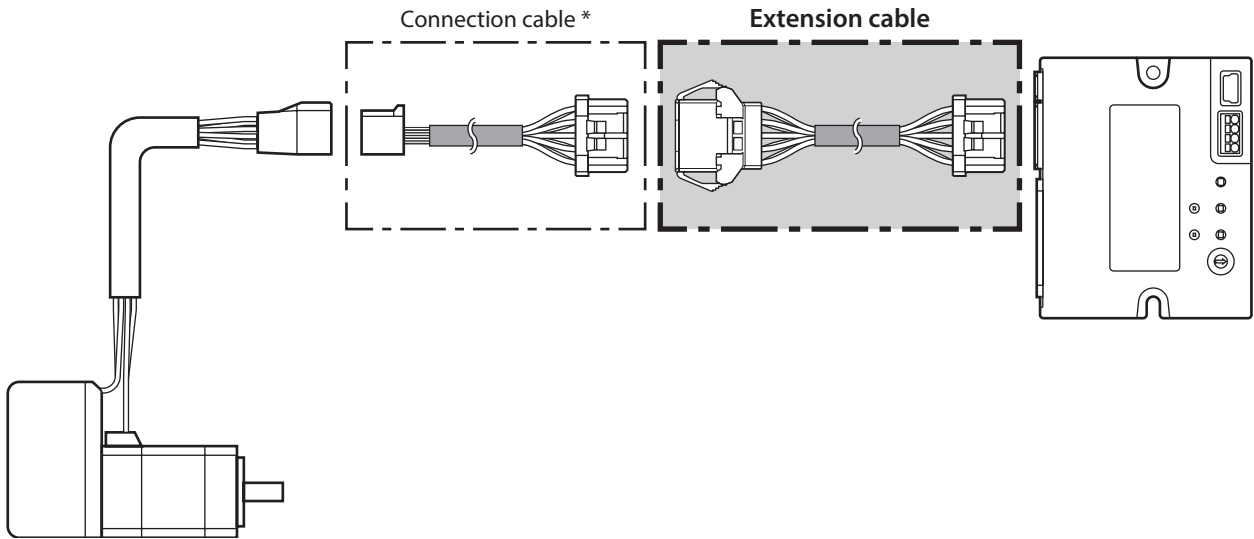

* Use the connection cable used.



- When installing the motor on a moving part, use a flexible cable.
- When extending the wiring length by connecting an extension cable to the connection cable, make the total cable length 10 m (32.8 ft.) or less.

● Extension cables

| Model | Length [m (ft.)] |
|---------------------|------------------|
| CCM010Z2ADFT | 1 (3.3) |
| CCM030Z2ADFT | 3 (9.8) |
| CCM050Z2ADFT | 5 (16.4) |

● Flexible extension cables

| Model | Length [m (ft.)] |
|---------------------|------------------|
| CCM010Z2ADRT | 1 (3.3) |
| CCM030Z2ADRT | 3 (9.8) |
| CCM050Z2ADRT | 5 (16.4) |

7-2 Connection cables (For connector type)

■ Connection cables/Flexible connection cables

These cables are used when connecting a motor and a driver.

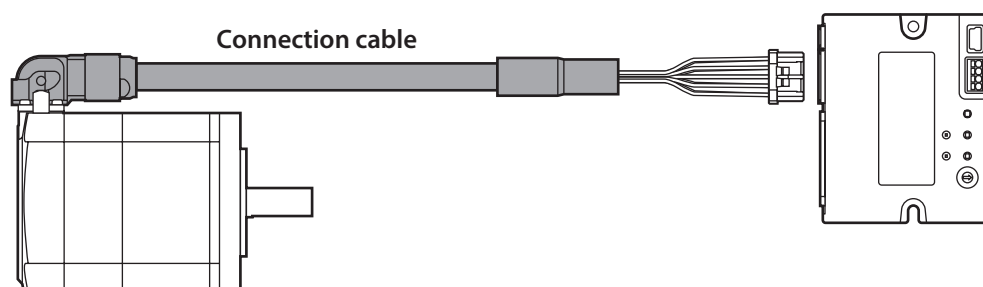

The model name of the connection cable varies depending on the outlet direction from the motor. Refer to the figures below.

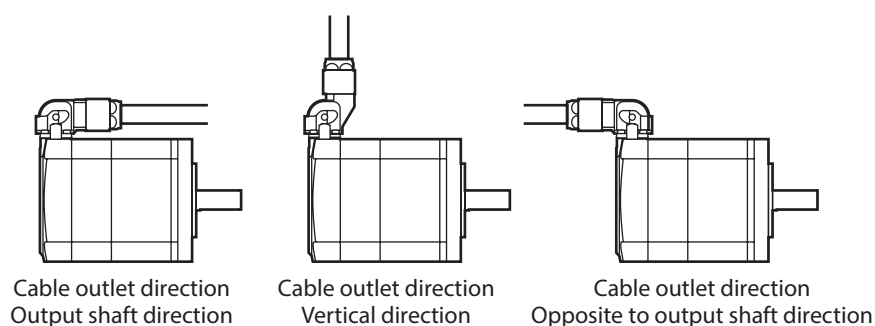

When installing the motor on a moving part, use a flexible cable.

● Connection cables

| Length [m (ft.)] | Cable outlet direction | | |
|---------------------|---------------------------|--------------------|---------------------------------------|
| | Output shaft direction | Vertical direction | Opposite to output shaft direction |
| 0.2 (0.7) | CCM002Z1EFF | CCM002Z1EVF | CCM002Z1EBF |
| 0.5 (1.6) | CCM005Z1EFF | CCM005Z1EVF | CCM005Z1EBF |
| 1 (3.3) | CCM010Z1EFF | CCM010Z1EVF | CCM010Z1EBF |
| 2 (6.6) | CCM020Z1EFF | CCM020Z1EVF | CCM020Z1EBF |
| 3 (9.8) | CCM030Z1EFF | CCM030Z1EVF | CCM030Z1EBF |
| 5 (16.4) | CCM050Z1EFF | CCM050Z1EVF | CCM050Z1EBF |
| 7 (23.0) | CCM070Z1EFF | CCM070Z1EVF | CCM070Z1EBF |
| 10 (32.8) | CCM100Z1EFF | CCM100Z1EVF | CCM100Z1EBF |

● Flexible connection cables

| Length [m (ft.)] | Cable outlet direction | | |
|---------------------|---------------------------|--------------------|---------------------------------------|
| | Output shaft direction | Vertical direction | Opposite to output shaft direction |
| 0.5 (1.6) | CCM005Z1EFR | CCM005Z1EVR | CCM005Z1EBR |
| 1 (3.3) | CCM010Z1EFR | CCM010Z1EVR | CCM010Z1EBR |
| 2 (6.6) | CCM020Z1EFR | CCM020Z1EVR | CCM020Z1EBR |
| 3 (9.8) | CCM030Z1EFR | CCM030Z1EVR | CCM030Z1EBR |
| 5 (16.4) | CCM050Z1EFR | CCM050Z1EVR | CCM050Z1EBR |
| 7 (23.0) | CCM070Z1EFR | CCM070Z1EVR | CCM070Z1EBR |
| 10 (32.8) | CCM100Z1EFR | CCM100Z1EVR | CCM100Z1EBR |

■ Extension cables/Flexible extension cables

These cables are used when extending a connection cable (add between the driver and connection cable). Use if the length of the connection cable used is not enough when extending the distance between a motor and a driver.

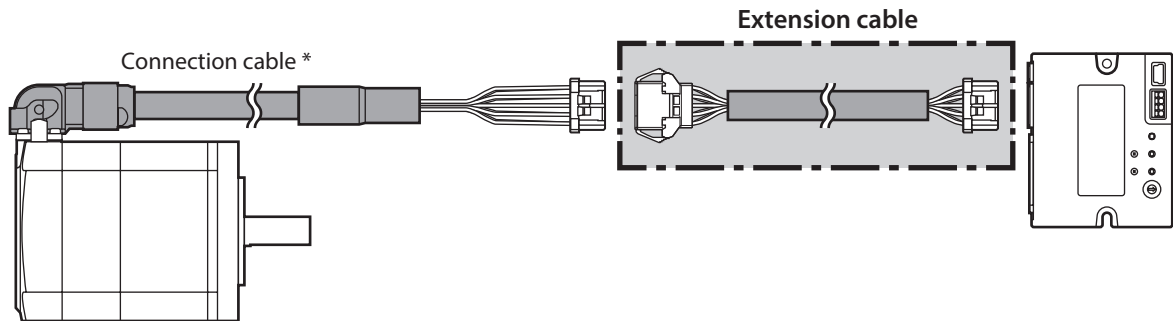

* Use the connection cable used.



- When installing the motor on a moving part, use a flexible cable.
- When extending the wiring length by connecting an extension cable to the connection cable, make the total cable length 10 m (32.8 ft.) or less.

● Extension cables

| Model | Length [m (ft.)] |
|---------------------|---------------------|
| CCM010Z2ADFT | 1 (3.3) |
| CCM030Z2ADFT | 3 (9.8) |
| CCM050Z2ADFT | 5 (16.4) |

● Flexible extension cables

| Model | Length [m (ft.)] |
|---------------------|---------------------|
| CCM010Z2ADRT | 1 (3.3) |
| CCM030Z2ADRT | 3 (9.8) |
| CCM050Z2ADRT | 5 (16.4) |

7-3 Power supply cable

This cable is used when connecting a driver to power supplies.

Model: **LCD06Z2AY** [0.6 m (2 ft.)]

3 Implicit communication

This part explains how to control via Implicit communication.

◆ Table of contents

| | | |
|----------|---|-----------|
| 1 | Flow of Implicit communication..... | 40 |
| 2 | Guidance | 41 |
| 3 | Communication specifications | 44 |
| 4 | Implicit message..... | 45 |
| | 4-1 Implicit message format | 45 |
| | 4-2 Input data | 46 |
| | 4-3 Output data | 49 |
| | 4-4 Processing order of Implicit communication | 53 |
| | 4-5 Data writing | 54 |
| | 4-6 Data reading | 55 |
| 5 | Example of execution for operation .. | 57 |
| | 5-1 Positioning operation | 57 |
| | 5-2 Continuous operation..... | 58 |
| 6 | Direct data operation | 59 |
| | 6-1 Overview of direct data operation | 59 |
| | 6-2 Output data and parameters required for direct data operation..... | 60 |
| | 6-3 Operation example | 63 |



1 Flow of Implicit communication

The contents of are explained in this manual.

Refer to the **AZ Series OPERATING MANUAL Function Edition** for the contents of .

 is the title name described in the reference destination.

memo Be sure to turn off the main power supply and control power supply of the driver before setting the switch. Setting the switch while the main power supply and/or the control power supply are in an on-state will not enable the new setting.

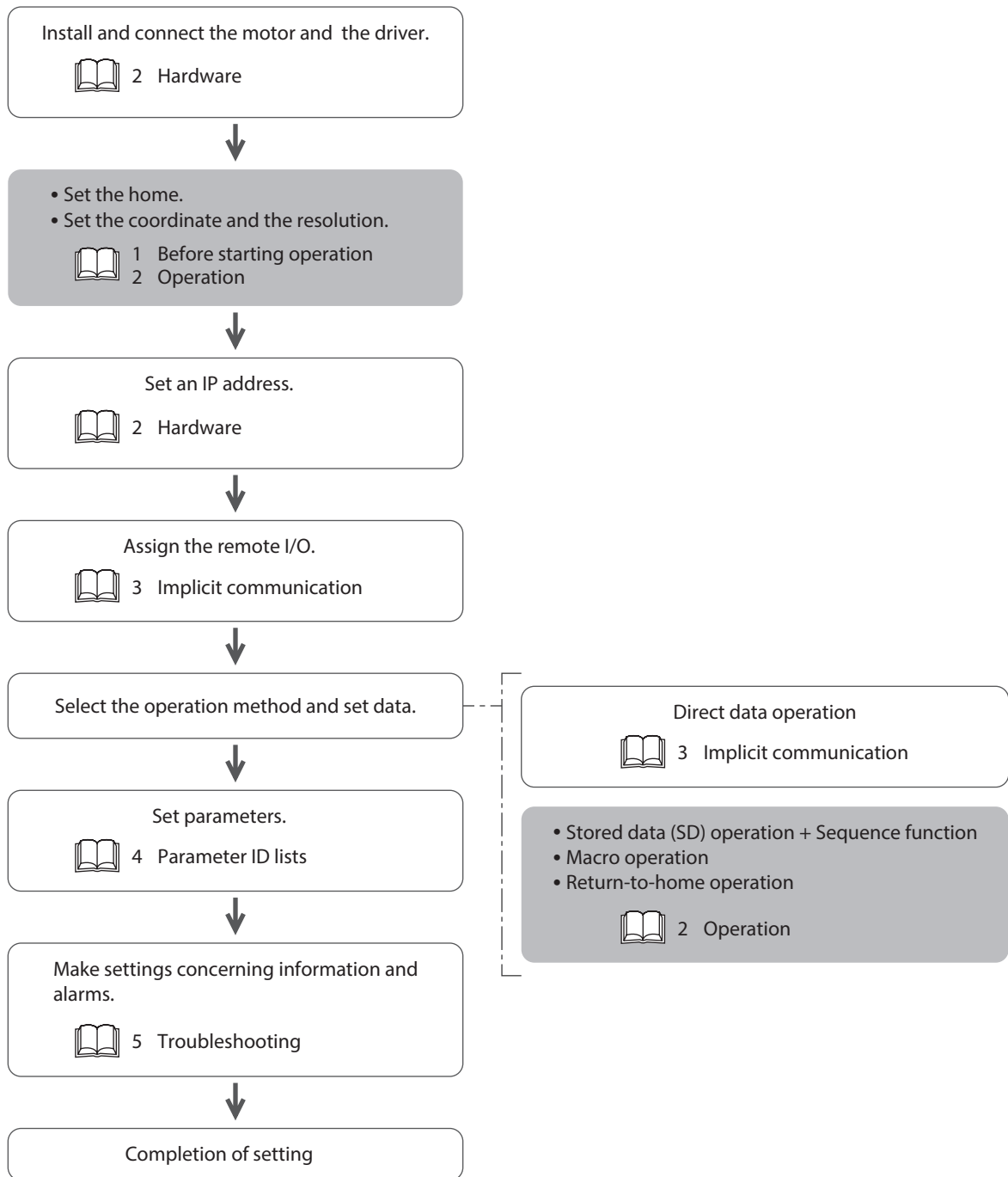

2 Guidance

If you are new to this product, read this chapter to understand the operating methods along with the operation flow. This is an example how to set the operation data and start the motor using a scanner.

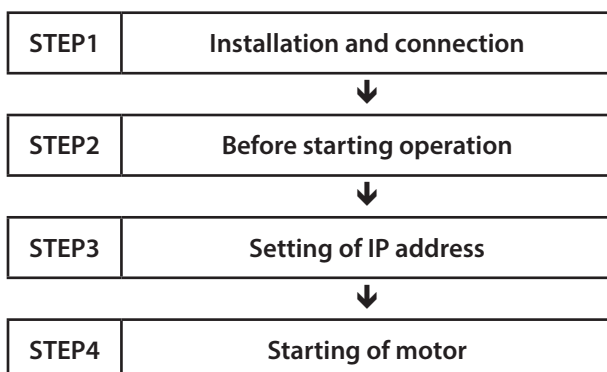

- **Operating conditions**

This operation is performed under the following conditions.

- | |
|---|
| <ul style="list-style-type: none">● Number of drivers connected: 1 unit● IP address: 192.168.1.2 |
|---|

Note

- Before operating the motor, check the condition of the surrounding area to ensure safety.
 - Before starting based on the guidance, import the EDS file to the setting tool of the scanner and register the system configuration in advance. For details, contact your nearest Oriental Motor sales office.
-

STEP 1 Check the installation and the connection.

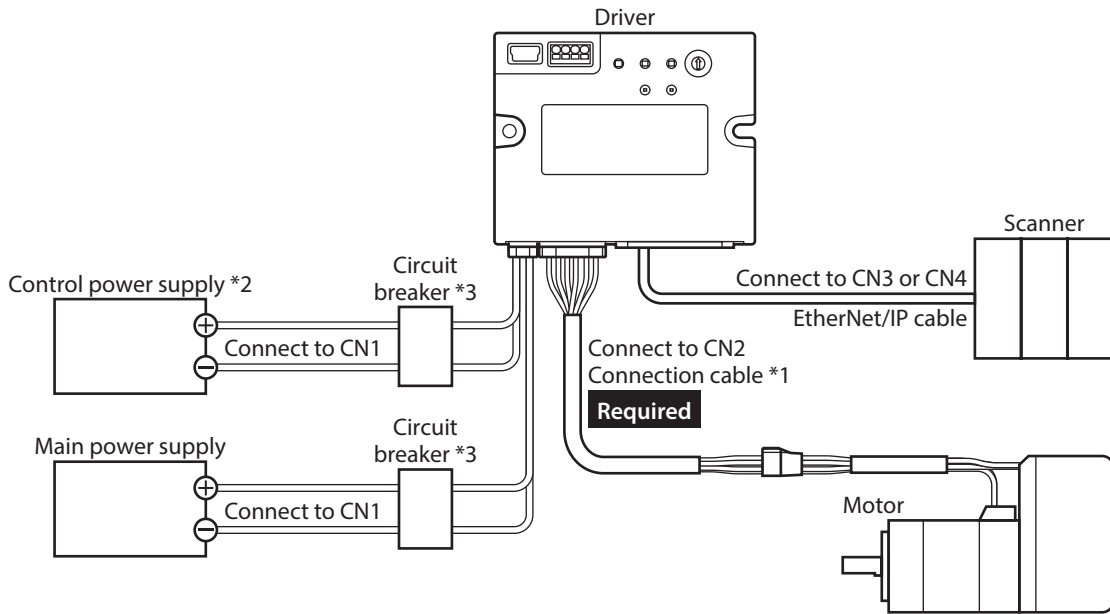

- *1 It is an Oriental motor cable. Purchase is required separately.
- *2 Connecting the control power supply allows you to continue monitoring even if the main power supply is shut off. Connect it as necessary.
- *3 It is recommended that a circuit breaker or a circuit protector is connected because incorrect wiring may cause the internal input circuit to short-circuit.

STEP 2 Make preparations for operation.

Refer to "Before starting operation" in the **AZ Series OPERATING MANUAL Function Edition**.

STEP 3 Set an IP address.

Set an IP address using the IP address setting switch (IP ADDR ×1) on the driver.

1. Set the IP address setting switch as shown below.

Setting: 2 (192.168.1.2)

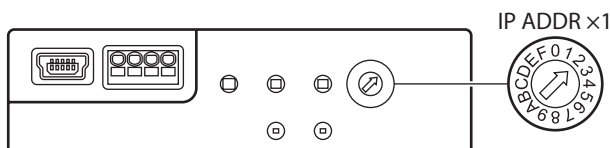

2. Turn on the main power supply and the control power supply again.

Note Be sure to turn off the main power supply and control power supply of the driver before setting the switch. Setting the switch while the main power supply and/or the control power supply are in an on-state will not enable the new setting.

STEP 4 The scanner starts the motor.

As an example, this section explains how to perform the following positioning operation.

● Setting example

- Operation data number: 1
- Position: 5,000 steps
- Other settings: Initial values

● Operation processing flow

Descriptions are given using the scanner as the subject.

1. Set the following operation data to turn the WR-REQ ON.
The operation data is set in the driver. When the setting is completed, the WR-END is turned ON.

| Byte | Description | Setting value | Note |
|----------|--------------------|---------------|---|
| 34, 35 | Write parameter ID | 3105 | Parameter ID of "Position" of operation data No.1 |
| 36 to 39 | Write data | 5,000 | Position: 5,000 steps |

2. Turn the WR-REQ OFF.
The WR-END is returned to OFF.
3. Check the READY has been turned ON.
4. Select the operation data No.1 to turn the START ON.
Positioning operation is started.
5. Check the READY has been turned OFF, and turn the START OFF.

STEP 5 Were you able to operate?

How did it go? Were you able to operate properly? If the motor does not operate, check the following points.

- Is the PWR/ALM LED blinking in red?
An alarm is being generated. Refer to p.101 for details.
- Are the main power supply, control power supply, the motor, and the EtherNet/IP cable connected securely?
- Is the IP address set correctly?
- Is the NS LED lit in red or blinking in red?
A communication error is being detected. Refer to p.100 for details.

3 Communication specifications

| | | |
|-----------------------------|------------------------------------|--|
| Communication standards | | EtherNet/IP (conforms to CT18) |
| Vendor ID | | 187: Oriental Motor Company |
| Device type | | 43: Generic Device |
| Transmission rate | | 10/100 Mbps (autonegotiation) |
| Communication mode | | Full duplex/Half duplex (autonegotiation) |
| Cable specifications | | Shielded twisted pair (STP) cable straight-through/crossover cable, category 5e or higher is recommended |
| Number of occupied bytes | Output (scanner → driver) | 40 bytes |
| | Input (driver → scanner) | 56 bytes |
| Implicit communication | Number of connections | 2 |
| | Connection type | Exclusive Owner, Input Only |
| | Communication cycle (RPI) | 1 to 3,200 ms |
| | Connection type (scanner → driver) | Point-to-Point |
| | Connection type (driver → scanner) | Point-to-Point, Multicast |
| | Data trigger | Cyclic |
| IP address setting method | | IP address setting switch, parameter, DHCP |
| Network topology | | Star, Linear bus, Ring (Device Level Ring) |

4 Implicit message

4-1 Implicit message format

This section shows transfer contents of implicit message. The order of data is in little-endian format.

| Byte | Input (driver → scanner) | Output (scanner → driver) |
|--------|-----------------------------------|--|
| 0, 1 | Remote I/O (R-OUT) | Remote I/O (R-IN) |
| 2, 3 | Operation data number selection_R | Operation data number selection |
| 4, 5 | Fixed I/O (OUT) | Fixed I/O (IN) |
| 6, 7 | Present alarm | Direct data operation operation type |
| 8, 9 | Feedback position (lower) | Direct data operation position (lower) |
| 10, 11 | Feedback position (upper) | Direct data operation position (upper) |
| 12, 13 | Feedback speed [Hz] (lower) | Direct data operation operating speed (lower) |
| 14, 15 | Feedback speed [Hz] (upper) | Direct data operation operating speed (upper) |
| 16, 17 | Command position (lower) | Direct data operation starting/changing rate (lower) |
| 18, 19 | Command position (upper) | Direct data operation starting/changing rate (upper) |
| 20, 21 | Torque monitor | Direct data operation stopping deceleration (lower) |
| 22, 23 | CST operating current | Direct data operation stopping deceleration (upper) |
| 24, 25 | Information (lower) | Direct data operation operating current |
| 26, 27 | Information (upper) | Direct data operation forwarding destination |
| 28, 29 | Reserved | Reserved |
| 30, 31 | Read parameter ID_R | Read parameter ID |
| 32, 33 | Read/write status | Write request |
| 34, 35 | Write parameter ID_R | Write parameter ID |
| 36, 37 | Read data (lower) | Write data (lower) |
| 38, 39 | Read data (upper) | Write data (upper) |
| 40, 41 | Assignable monitor 0 (lower) | – |
| 42, 43 | Assignable monitor 0 (upper) | – |
| 44, 45 | Assignable monitor 1 (lower) | – |
| 46, 47 | Assignable monitor 1 (upper) | – |
| 48, 49 | Assignable monitor 2 (lower) | – |
| 50, 51 | Assignable monitor 2 (upper) | – |
| 52, 53 | Assignable monitor 3 (lower) | – |
| 54, 55 | Assignable monitor 3 (upper) | – |

Note For Implicit message, all data in the message format is periodically exchanged between the driver and the scanner. Therefore, check all data when setting it. If only some data is set, the data that is not set will be undefined, which may cause the driver to malfunction.

4-2 Input data

Data transferred from a driver to a scanner is called Input data.

Input data format

Contents of the Input data are as follows. The order of data is in little-endian format.

| Assembly Instance | Attribute | Byte | Size (byte) | Description |
|-------------------|-----------|----------------------|-------------|-----------------------------------|
| 100 | 3 | 0, 1 | 2 | Remote I/O (R-OUT) |
| | | 2, 3 | 2 | Operation data number selection_R |
| | | 4, 5 | 2 | Fixed I/O (OUT) |
| | | 6, 7 | 2 | Present alarm |
| | | 8 to 11 | 4 | Feedback position |
| | | 12 to 15 | 4 | Feedback speed |
| | | 16 to 19 | 4 | Command position |
| | | 20, 21 | 2 | Torque monitor |
| | | 22, 23 | 2 | CST operating current |
| | | 24 to 27 | 4 | Information |
| | | 28, 29 | 2 | Reserved |
| | | 30, 31 | 2 | Read parameter ID_R |
| | | 32, 33 | 2 | Read/write status |
| | | 34, 35 | 2 | Write parameter ID_R |
| | | 36 to 39 | 4 | Read data |
| | | 40 to 43 | 4 | Assignable monitor 0 |
| 44 to 47 | 4 | Assignable monitor 1 | | |
| 48 to 51 | 4 | Assignable monitor 2 | | |
| 52 to 55 | 4 | Assignable monitor 3 | | |

Details of Input data

Remote I/O (R-OUT)

This is the I/O accessed via EtherNet/IP.

The assignments of signals can be changed using the "R-OUT output function" parameters.

| Bit | Name | Description | Initial assignment |
|-----|---------|---|--------------------|
| 0 | R-OUT0 | Output in response to a signal assigned with the "R-OUT output function" parameter. | 64: M0_R |
| 1 | R-OUT1 | | 65: M1_R |
| 2 | R-OUT2 | | 66: M2_R |
| 3 | R-OUT3 | | 32: START_R |
| 4 | R-OUT4 | | 144: HOME-END |
| 5 | R-OUT5 | | 132: READY |
| 6 | R-OUT6 | | 135: INFO |
| 7 | R-OUT7 | | 129: ALM-A |
| 8 | R-OUT8 | | 136: SYS-BSY |
| 9 | R-OUT9 | | 160: AREA0 |
| 10 | R-OUT10 | | 161: AREA1 |
| 11 | R-OUT11 | | 162: AREA2 |
| 12 | R-OUT12 | | 157: TIM |
| 13 | R-OUT13 | | 134: MOVE |
| 14 | R-OUT14 | | 138: IN-POS |
| 15 | R-OUT15 | | 140: TLC |

- **Operation data number selection_R**

| Bit | Name | Description |
|---------|----------|--|
| 0 | M0_R | Output in response to an input signal. |
| 1 | M1_R | |
| 2 | M2_R | |
| 3 | M3_R | |
| 4 | M4_R | |
| 5 | M5_R | |
| 6 | M6_R | |
| 7 | M7_R | |
| 8 to 15 | Reserved | 0 is returned. |

- **Fixed I/O (OUT)**

This is the I/O accessed via EtherNet/IP. Assignments of signals cannot be changed.

| Bit | Name | Description |
|-----|-------------|---|
| 0 | SEQ-BSY | Output while stored data operation is performed. |
| 1 | MOVE | Output while the motor operates. |
| 2 | IN-POS | Output when positioning operation is completed. |
| 3 | START_R | Output in response to an input signal. |
| 4 | HOME-END | Output when high-speed return-to-home operation or return-to-home operation is completed, or position preset is executed. |
| 5 | READY | Output when the driver is ready to operate. |
| 6 | DCMD-RDY | Output when the driver is ready to start direct data operation. |
| 7 | ALM-A | Output the alarm status of the driver. (Normally open) |
| 8 | TRIG_R | Output in response to an input signal. |
| 9 | TRIG-MODE_R | Output in response to an input signal. |
| 10 | SET-ERR | Output when an error occurs in any of the settings of the operation type, position, operating speed, starting/changing speed rate, stopping deceleration, operating current, or forwarding destination for direct data operation. |
| 11 | EXE-ERR | Output when direct data operation is failed to execute. |
| 12 | DCMD-FULL | Output when data is being written to the buffer area of direct data operation. |
| 13 | STOP_R | Output in response to an input signal. |
| 14 | Reserved | 0 is returned. |
| 15 | TLC | Output when the output torque reaches the upper limit value. |

- **Present alarm**

| Bit | Name | Description |
|---------|---------------|--|
| 0 to 15 | Present alarm | This indicates the alarm code presently being generated. |

- **Feedback position**

| Bit | Name | Description |
|---------|-------------------|--|
| 0 to 31 | Feedback position | This indicates the present feedback position. (step) When the wrap function is enabled, the value on the wrap coordinates is indicated. |

- **Feedback speed**

| Bit | Name | Description |
|---------|----------------|---|
| 0 to 31 | Feedback speed | This indicates the present feedback speed. (Hz) |

● **Command position**

| Bit | Name | Description |
|---------|------------------|---|
| 0 to 31 | Command position | This indicates the present command position. (step) When the wrap function is enabled, the value on the wrap coordinates is indicated. |

● **Torque monitor**

| Bit | Name | Description |
|---------|----------------|--|
| 0 to 15 | Torque monitor | This indicates the torque presently generated as a percentage of the maximum holding torque. (1=0.1 %) |

● **CST operating current**

| Bit | Name | Description |
|---------|-----------------------|--|
| 0 to 15 | CST operating current | This indicates the operating current of the α control (CST) mode. (1=0.1 %) |

● **Information**

| Bit | Name | Description |
|---------|-------------|--|
| 0 to 31 | Information | This indicates the information code presently being generated. |

● **Read parameter ID_R**

| Bit | Name | Description |
|---------|---------------------|---|
| 0 to 15 | Read parameter ID_R | This indicates a response of the read parameter ID. |

● **Read/write status**

| Bit | Name | Description |
|--------|------------|--|
| 0 to 6 | Reserved | 0 is returned. |
| 7 | RD-ERR | Output when an error occurred in reading. If reading is performed properly, the RD-REQ is turned OFF |
| 8 | WR-END | Output in response to the WR-REQ. The WR-END is also turned ON while the WR-REQ is ON. OFF: Write request waiting ON: Write completed |
| 9 | SYS-BSY | Output when the driver is in an internal processing state. |
| 10 | Reserved | 0 is returned. |
| 11 | WR-SET-ERR | Output when the write parameter ID or write data is out of the setting range. |
| 12 | WR-IF-ERR | Output when writing cannot be performed due to user I/F communication in progress. |
| 13 | WR-NV-ERR | Output when writing cannot be performed due to non-volatile memory processing in progress. |
| 14 | WR-EXE-ERR | Output when a command cannot be executed. |
| 15 | WR-ERR | Output when an error occurred in writing. If the WR-REQ is turned OFF or writing is performed properly, the WR-ERR is also turned OFF. |

● **Write parameter ID_R**

| Bit | Name | Description |
|---------|----------------------|---|
| 0 to 15 | Write parameter ID_R | This indicates a response of the write parameter ID . |

● **Read data**

| Bit | Name | Description |
|---------|-----------|--|
| 0 to 31 | Read data | This indicates the value of the parameter shown in the parameter ID_R. |

- **Assignable monitor**

| Bit | Name | Description |
|---------|------------------------|--|
| 0 to 31 | Assignable monitor n * | This indicates the value of the parameter set in the "Assignable monitor address n" parameter. |

* n: 0 to 3

4-3 Output data

Data transferred from a scanner to a driver is called Output data.

- **Output data format**

Contents of the Output data are as follows. The order of data is in little-endian format.

| Assembly Instance | Attribute | Byte | Size (byte) | Description |
|-------------------|-----------|----------|-------------|--|
| 101 | 3 | 0, 1 | 2 | Remote I/O (R-IN) |
| | | 2, 3 | 2 | Operation data number selection |
| | | 4, 5 | 2 | Fixed I/O (IN) |
| | | 6, 7 | 2 | Direct data operation operation type |
| | | 8 to 11 | 4 | Direct data operation position |
| | | 12 to 15 | 4 | Direct data operation operating speed |
| | | 16 to 19 | 4 | Direct data operation starting/changing rate |
| | | 20 to 23 | 4 | Direct data operation stopping deceleration |
| | | 24, 25 | 2 | Direct data operation operating current |
| | | 26, 27 | 2 | Direct data operation forwarding destination |
| | | 28, 29 | 2 | Reserved |
| | | 30, 31 | 2 | Read parameter ID |
| | | 32, 33 | 2 | Write request |
| | | 34, 35 | 2 | Write parameter ID |
| | | 36 to 39 | 4 | Write data |

■ Details of Output data

- Remote I/O (R-IN)

This is the I/O accessed via EtherNet/IP.

The assignments of signals can be changed using the “R-IN input function” parameters.

| Bit | Name | Description | Initial assignment |
|-----|--------|---|--------------------|
| 0 | R-IN0 | These are used to execute the signal assigned with the “R-IN input function” parameter. | 0: Not used |
| 1 | R-IN1 | | |
| 2 | R-IN2 | | |
| 3 | R-IN3 | | |
| 4 | R-IN4 | | |
| 5 | R-IN5 | | |
| 6 | R-IN6 | | |
| 7 | R-IN7 | | |
| 8 | R-IN8 | | |
| 9 | R-IN9 | | |
| 10 | R-IN10 | | |
| 11 | R-IN11 | | |
| 12 | R-IN12 | | |
| 13 | R-IN13 | | |
| 14 | R-IN14 | | |
| 15 | R-IN15 | | |

- Operation data number selection

| Bit | Name | Description | Initial value |
|---------|----------|---|---------------|
| 0 | M0 | The operation data number is selected using these eight bits. | 0 |
| 1 | M1 | | |
| 2 | M2 | | |
| 3 | M3 | | |
| 4 | M4 | | |
| 5 | M5 | | |
| 6 | M6 | | |
| 7 | M7 | | |
| 8 to 15 | Reserved | A value is disregarded. | 0 |

● **Fixed I/O (IN)**

This is the I/O accessed via EtherNet/IP.
 Assignments of signals cannot be changed.

| Bit | Name | Description | Initial value |
|-----|-----------|--|---------------|
| 0 | FW-JOG | This is used to execute JOG operation in the forward direction. | 0 |
| 1 | RV-JOG | This is used to execute JOG operation in the reverse direction. | |
| 2 | Reserved | A value is disregarded. | |
| 3 | START | This is used to execute stored data operation. | |
| 4 | ZHOME | This is used to execute high-speed return-to-home operation. | |
| 5 | STOP | This is used to stop the motor. | |
| 6 | FREE | This is used to shut off the motor current to put the motor into a non-excitation state. When an electromagnetic brake motor is used, the electromagnetic brake is in a state of releasing the motor shaft. | |
| 7 | ALM-RST | This is used to reset the alarm generated presently. | |
| 8 | TRIG | This is used to execute direct data operation. | |
| 9 | TRIG-MODE | This is used to set the judgment level for the TRIG. 0: Start at ON edge 1: Start at ON level | |
| 10 | Reserved | A value is disregarded. | |
| 11 | Reserved | A value is disregarded. | |
| 12 | FW-JOG-P | This is used to execute inching operation in the forward direction. | |
| 13 | RV-JOG-P | This is used to execute inching operation in the reverse direction. | |
| 14 | FW-POS | This is used to execute continuous operation in the forward direction. | |
| 15 | RV-POS | This is used to execute continuous operation in the reverse direction. | |

● **Direct data operation operation type**

| Bit | Name | Description | Initial value |
|---------|--------------------------------------|--|---------------|
| 0 to 15 | Direct data operation operation type | This is used to set the operation type for direct data operation. [Setting range] 0: No setting 1: Absolute positioning 2: Incremental positioning (based on command position) 3: Incremental positioning (based on feedback position) 7: Continuous operation (Position control) 8: Wrap absolute positioning 9: Wrap proximity positioning 10: Wrap forward direction absolute positioning 11: Wrap reverse direction absolute positioning 12: Wrap absolute push-motion 13: Wrap proximity push-motion 14: Wrap forward direction push-motion 15: Wrap reverse direction push-motion 16: Continuous operation (Speed control) 17: Continuous operation (Push-motion) 18: Continuous operation (Torque control) 20: Absolute positioning push-motion 21: Incremental positioning push-motion (based on command position) 22: Incremental positioning push-motion (based on feedback position) | 2 |

● Direct data operation position

| Bit | Name | Description | Initial value |
|---------|--------------------------------|--|---------------|
| 0 to 31 | Direct data operation position | This is used to set the target position for direct data operation. [Setting range] -2,147,483,648 to 2,147,483,647 steps | 0 |

● Direct data operation operating speed

| Bit | Name | Description | Initial value |
|---------|---------------------------------------|---|---------------|
| 0 to 31 | Direct data operation operating speed | This is used to set the operating speed for direct data operation. [Setting range] -4,000,000 to 4,000,000 Hz | 1,000 |

● Direct data operation starting/changing rate

| Bit | Name | Description | Initial value |
|---------|--|--|---------------|
| 0 to 31 | Direct data operation starting/changing rate | This is used to set the starting/changing rate or the starting/ changing time for direct data operation. [Setting range] 1 to 1,000,000,000 (1=0.001 kHz/s, 1=0.001 s, or 1=0.001 ms/kHz) | 1,000,000 |

● Direct data operation stopping deceleration

| Bit | Name | Description | Initial value |
|---------|---|--|---------------|
| 0 to 31 | Direct data operation stopping deceleration | This is used to set the stopping deceleration rate or the stop time for direct data operation. [Setting range] 1 to 1,000,000,000 (1=0.001 kHz/s, 1=0.001 s, or 1=0.001 ms/kHz) | 1,000,000 |

● Direct data operation operating current

| Bit | Name | Description | Initial value |
|---------|---|---|---------------|
| 0 to 15 | Direct data operation operating current | This is used to set the operating current for direct data operation. [Setting range] 0 to 1,000 (1=0.1 %) | 1,000 |

● Direct data operation forwarding destination

| Bit | Name | Description | Initial value |
|---------|--|---|---------------|
| 0 to 15 | Direct data operation forwarding destination | This is used to select the stored area when the next direct data is transferred during direct data operation. [Setting range] 0: Execution memory 1: Buffer memory | 0 |

● Read parameter ID

| Bit | Name | Description | Initial value |
|---------|-------------------|---|---------------|
| 0 to 15 | Read parameter ID | This is used to set the parameter ID to be read from. | 0 |

- Write request

| Bit | Name | Description | Initial value |
|---------|----------|---|---------------|
| 0 | WR-REQ | This is used to set the write request. [Setting range] 0: Disable 1: Write request (ON edge) | 0 |
| 1 to 15 | Reserved | A value is disregarded. | 0 |

- Write parameter ID

| Bit | Name | Description | Initial value |
|---------|--------------------|--|---------------|
| 0 to 15 | Write parameter ID | This is used to set the parameter ID to be written to. | 0 |

- Write data

| Bit | Name | Description | Initial value |
|---------|------------|---|---------------|
| 0 to 31 | Write data | This is used to set a value to be written to the parameter specified by the write parameter ID. | 0 |

4-4 Processing order of Implicit communication

The processing order of Implicit communication is shown below.

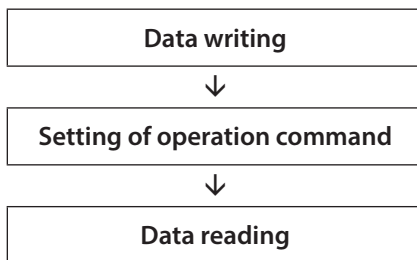

- If multiple operation commands are set in the Implicit message format, the operation command of direct data operation is prioritized.
- If the operation commands for remote I/O (R-IN) and fixed I/O (IN) are set at the same time, operation will be as follows.
 - If the same operation command is set: The motor will start.
 - If different operation commands are set: The motor will not start, and information of Start operation error will be generated.

4-5 Data writing

This section explains the flow that data is written from the scanner to the driver via Implicit communication.

■ Area of Implicit message format used

Input (transfer from driver to scanner)

| Byte | Description |
|--------|----------------------|
| 32, 33 | Read/write status |
| 34, 35 | Write parameter ID_R |

Output (transfer from scanner to driver)

| Byte | Description |
|----------|--------------------|
| 32, 33 | Write request |
| 34, 35 | Write parameter ID |
| 36 to 39 | Write data |

■ Flow that data is written to

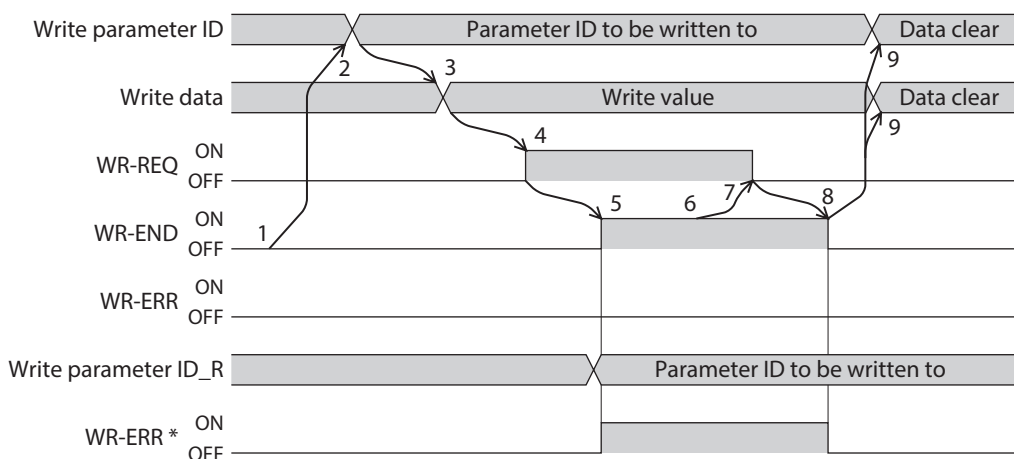
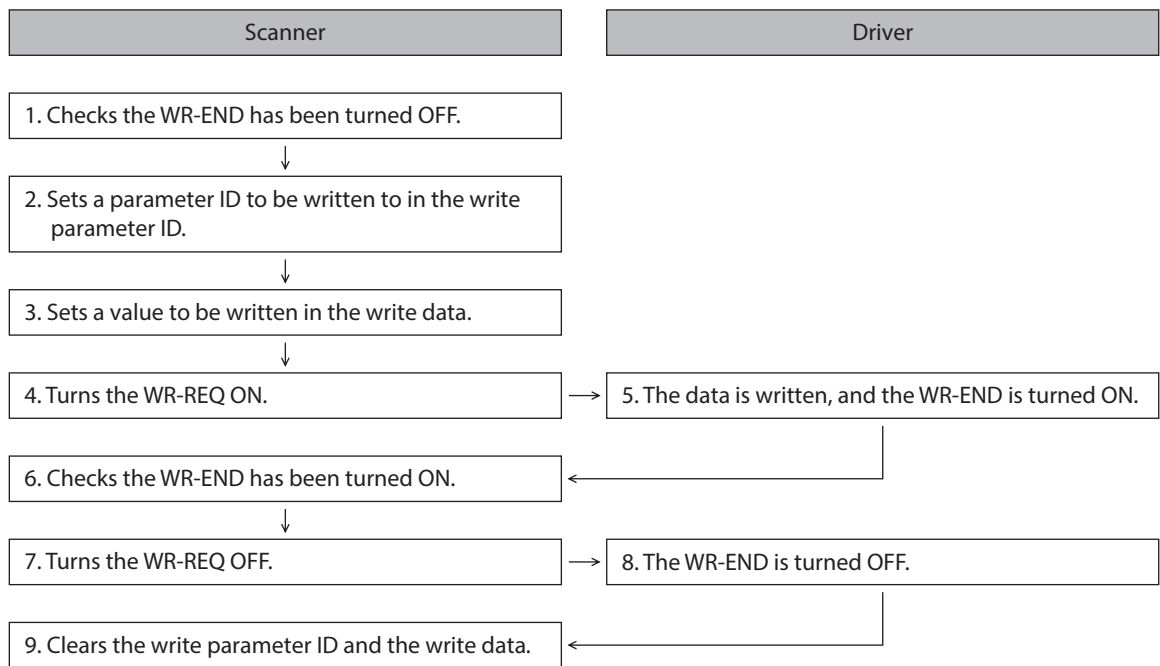

* If an error occurs while data is being written, the WR-END and WR-ERR are simultaneously turned ON.

4-6 Data reading

This section explains the flow that data is read from the driver to the scanner via Implicit communication. There are the following two methods to read data.

- Use an area of "Read data"
- Use an area of "Assignable monitor"

■ When an area of read data is used

● Area of Implicit message format used

Input (transfer from driver to scanner)

| Byte | Description |
|----------|---------------------|
| 30, 31 | Read parameter ID_R |
| 32, 33 | Read/write status |
| 36 to 39 | Read data |

Output (transfer from scanner to driver)

| Byte | Description |
|--------|-------------------|
| 30, 31 | Read parameter ID |

● Flow that data is read from

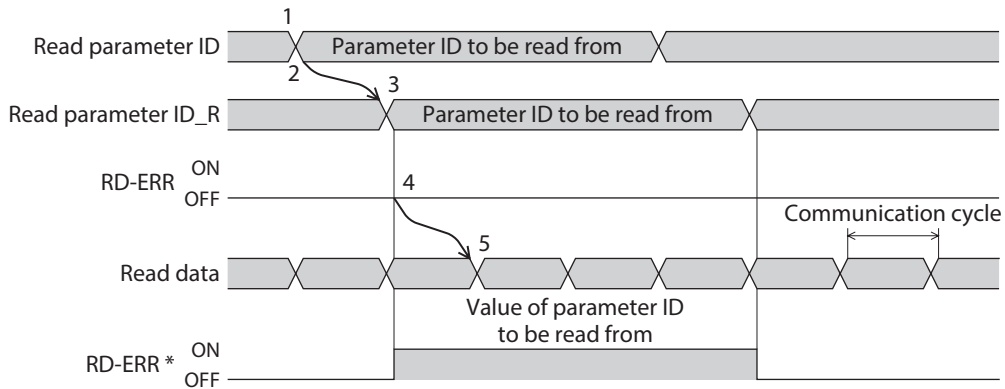
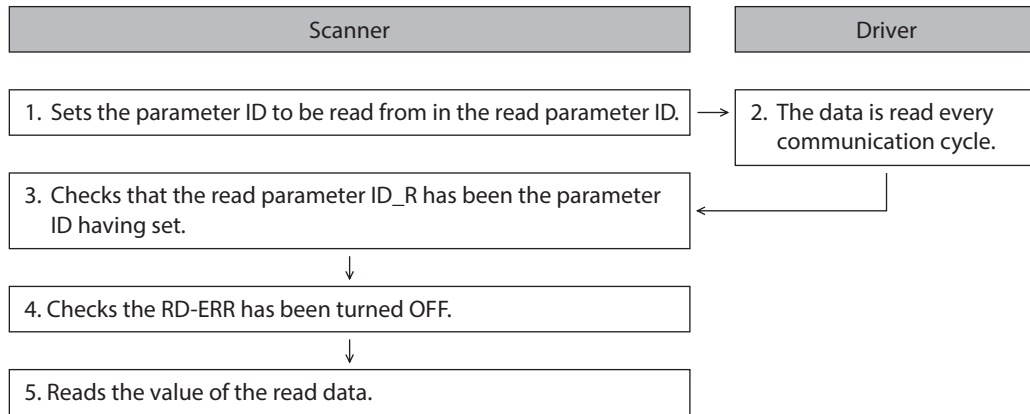

* If the parameter ID out of setting range is set to the read parameter ID, the RD-ERR is turned ON at the same time when the read parameter ID_R is updated.

■ **When an area of assignable monitor is used**

- Area of Implicit message format used

Input (transfer from driver to scanner)

| Byte | Description |
|----------|--|
| 40 to 55 | Assignable monitor 0 to assignable monitor 3 |

- Flow that data is read from

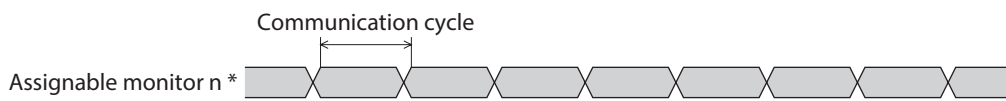
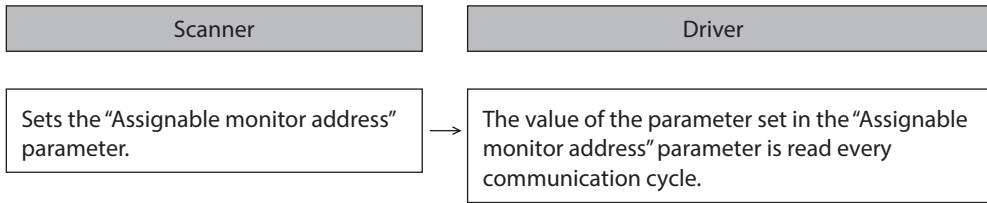

* n: 0 to 3

- Related parameters

| Parameter ID | | Name | Description | Initial value |
|--------------|-------|------------------------------|--|------------------------------|
| Dec | Hex | | | |
| 25600 | 6400h | Assignable monitor address 0 | Sets the parameter ID to show on the assignable monitor. [Setting range] Set from items of "3 Monitor commands" on p.70 | 124: Driver temperature |
| 25601 | 6401h | Assignable monitor address 1 | | 125: Motor temperature |
| 25602 | 6402h | Assignable monitor address 2 | | 109: Cumulative load monitor |
| 25603 | 6403h | Assignable monitor address 3 | | 127: Tripmeter |

5 Example of execution for operation

This chapter describes operations that operation data is set using the write data area. The method to execute operation is common to fixed I/O and remote I/O.

5-1 Positioning operation

As an example, this section explains how to perform the following positioning operation.

- **Setting example**

- Operation data number: 1
- Position: 5,000 steps
- Other settings: Initial values

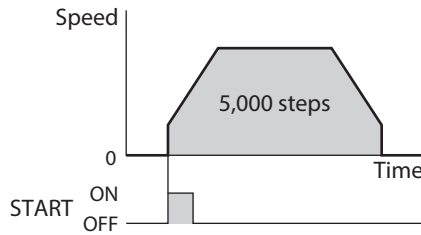

- **Operation processing flow**

Descriptions are given using the scanner as the subject.

1. Set the following operation data to turn the WR-REQ ON.
The operation data is set in the driver. When the setting is completed, the WR-END is turned ON.

- Output (scanner → driver)

| Byte | Description | Setting value | Note |
|----------|--------------------|---------------|---|
| 34, 35 | Write parameter ID | 3105 | Parameter ID of "Position" of operation data No.1 |
| 36 to 39 | Write data | 5,000 | Position: 5,000 steps |

- Input (driver → scanner)

| Byte | Description | Response | Note |
|--------|----------------------|----------|---|
| 34, 35 | Write parameter ID_R | 3105 | Parameter ID of "Position" of operation data No.1 |

2. Turn the WR-REQ OFF.
The WR-END is returned to OFF.
3. Check the READY has been turned ON.
4. Select the operation data No.1 to turn the START ON.
Positioning operation is started.
5. Check the READY has been turned OFF, and turn the START OFF.

5-2 Continuous operation

As an example, this section explains how to perform the following continuous operation.

- **Setting example**

- Operation data number: 0
- Rotation direction: Forward direction
- Other settings: Initial values

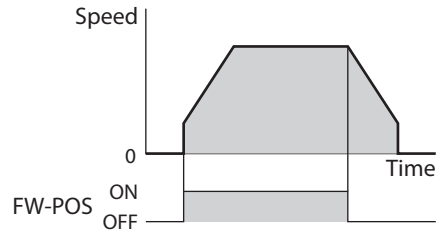

- **Operation processing flow**

Descriptions are given using the scanner as the subject.

1. Check the READY has been turned ON.
2. Set the following operation data to turn the FW-POS ON.
Continuous operation is started.

- Output (scanner → driver)

| Byte | Description | Setting value | Note |
|------|---------------------------------|---------------|--------------------------------------|
| 2, 3 | Operation data number selection | 0 | The operation data No.0 is selected. |

3. To stop continuous operation, turn the FW-POS OFF.
The motor decelerates to a stop.

6 Direct data operation

6-1 Overview of direct data operation

Direct data operation is a mode that allows start of operation at the same time as rewriting of data.

It is suitable to frequently change operation data such as the position (travel amount) or the operating speed, or to applications to adjust the position finely.

There are the following seven types of triggers to start operation at the same time as rewriting of data.

- One of the following items: Operation type, position, operating speed, starting/changing speed rate, stopping deceleration, and operating current
- The above six items are collectively rewritten

Direct data operation is executed with the TRIG of fixed I/O (IN).

A condition to execute direct data operation can be selected from the following two types using the TRIG-MODE of fixed I/O (IN).

- Start at ON edge of TRIG: The motor will start according to the operation data being set when the TRIG is turned ON.
- Start at ON level of TRIG: The motor will start at the same time when the data of the trigger set in the "Direct data operation trigger setting" parameter is changed.

■ Application example 1 of direct data operation

The position (travel amount) or the operating speed should be adjusted each time a load is changed because the feed rate is different in each load.

● Setting example

- Position (travel amount): Change as desired
- Operating speed: Change as desired
- TRIG-MODE: Start at ON edge of TRIG

● Operation processing flow

Descriptions are given using the scanner as the subject.

1. Write the position and the operating speed.
2. Turn the TRIG ON.

● Result

When the TRIG is turned ON, the changed value is updated immediately, and operation is performed with the new position and operating speed.

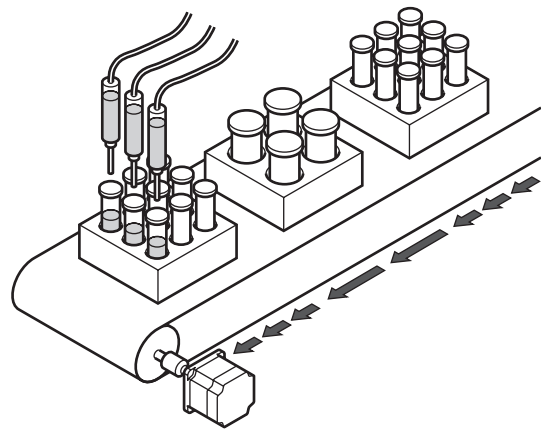

■ Application example 2 of direct data operation

The operating speed should be changed immediately with the touch screen because a large load is inspected at a lower speed.

● Setting example

- Operating speed: Change as desired
- Trigger: Operating speed (setting value of trigger: -4)
- TRIG-MODE: Start at ON level of TRIG

● Operation processing flow

Descriptions are given using the scanner as the subject.

1. Write “-4” to the “Direct data operation trigger setting” parameter.
2. Write the data of the operating speed.
3. Turn the TRIG ON.
4. Change the operating speed.

● Result

When the TRIG is turned ON, operation is started. If the operating speed is changed, the changed value is updated immediately, and the operation is performed at the new operating speed.

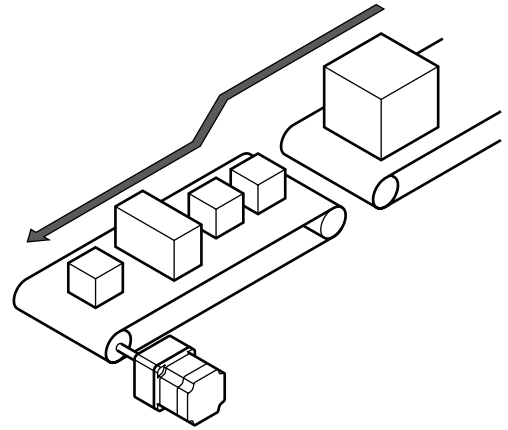

6-2 Output data and parameters required for direct data operation

● Related Output data

| Byte | Name | Description | Initial value |
|----------|---------------------------------------|--|---------------|
| 6, 7 | Direct data operation operation type | This is used to set the operation type for direct data operation. [Setting range] 0: No setting 1: Absolute positioning 2: Incremental positioning (based on command position) 3: Incremental positioning (based on feedback position) 7: Continuous operation (Position control) 8: Wrap absolute positioning 9: Wrap proximity positioning 10: Wrap forward direction absolute positioning 11: Wrap reverse direction absolute positioning 12: Wrap absolute push-motion 13: Wrap proximity push-motion 14: Wrap forward direction push-motion 15: Wrap reverse direction push-motion 16: Continuous operation (Speed control) 17: Continuous operation (Push-motion) 18: Continuous operation (Torque control) 20: Absolute positioning push-motion 21: Incremental positioning push-motion (based on command position) 22: Incremental positioning push-motion (based on feedback position) | 2 |
| 8 to 11 | Direct data operation position | This is used to set the target position for direct data operation. [Setting range] -2,147,483,648 to 2,147,483,647 steps | 0 |
| 12 to 15 | Direct data operation operating speed | This is used to set the operating speed for direct data operation. [Setting range] -4,000,000 to 4,000,000 Hz | 1,000 |

| Byte | Name | Description | Initial value |
|----------|--|---|---------------|
| 16 to 19 | Direct data operation starting/changing rate | This is used to set the acceleration/deceleration rate or the acceleration/deceleration time for direct data operation. [Setting range] 1 to 1,000,000,000 (1=0.001 kHz/s, 1=0.001 s, or 1=0.001 ms/kHz) | 1,000,000 |
| 20 to 23 | Direct data operation stopping deceleration | This is used to set the stopping deceleration rate or the stop time for direct data operation. [Setting range] 1 to 1,000,000,000 (1=0.001 kHz/s, 1=0.001 s, or 1=0.001 ms/kHz) | 1,000,000 |
| 24, 25 | Direct data operation operating current | This is used to set the operating current for direct data operation. [Setting range] 0 to 1,000 (1=0.1 %) | 1,000 |
| 26, 27 | Direct data operation forwarding destination | This is used to select the stored area when the next direct data is transferred during direct data operation. [Setting range] 0: Execution memory 1: Buffer memory | 0 |

● Related parameter

| Parameter ID | | Name | Description | Initial value |
|--------------|-------|---------------------------------------|--|---------------|
| Dec | Hex | | | |
| 24852 | 6114h | Direct data operation trigger setting | Sets the trigger to execute direct data operation. The trigger setting is enabled only when the TRIG-MODE is set to "1: Start at ON level." [Setting range] -6: Operation type -5: Position -4: Operating speed -3: Starting/changing speed rate -2: Stopping deceleration -1: Operating current 0: Disable 1: All data updated | 1 |

■ Trigger setting

This is a trigger to start operation at the same time as rewriting of data in direct data operation. The trigger setting is enabled only when the TRIG-MODE is set to "1: Start at ON level."

● When the trigger setting is "0"

Direct data operation is disabled.

● When the trigger setting is "1"

When the TRIG is turned from OFF to ON, direct data operation is started. After that, if any of data is changed, the motor will be started. The motor will be started only when data is changed.

● When the trigger setting is "-1 to -6"

When the TRIG is turned from OFF to ON, direct data operation is started. After that, only when the data corresponding to the trigger is changed, the motor will be started. Even if data other than the trigger is changed, the motor will not be started.

■ Data forwarding destination

During direct data operation, the stored area when the next direct data is transferred can be selected.

- **When the forwarding destination is set to “0: Execution memory”**

If the TRIG is turned from OFF to ON or the data corresponding to the trigger is changed, the data during operation can be rewritten to the next direct data.

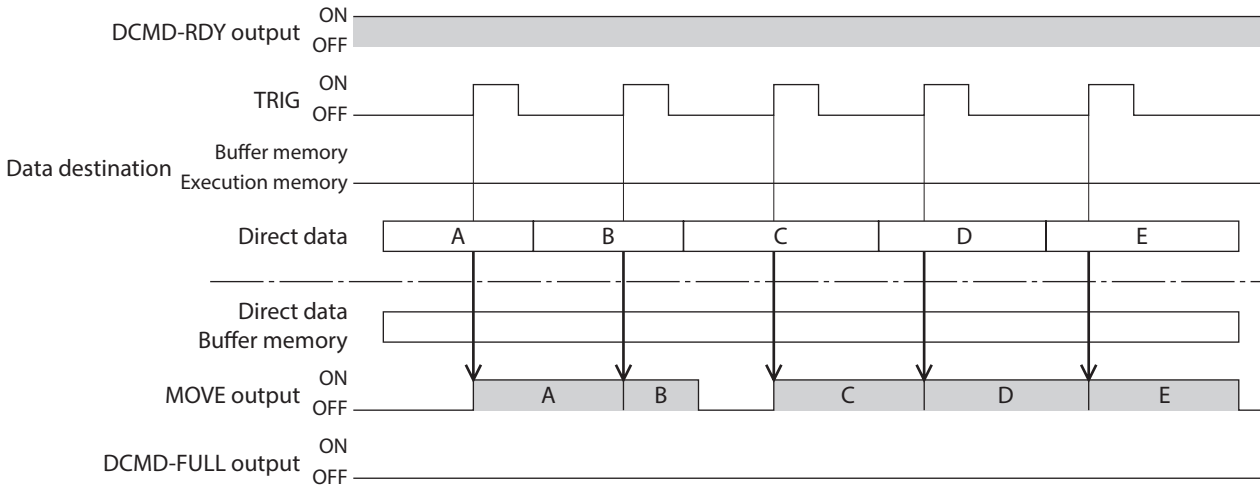

- **When the forwarding destination is set to “1: Buffer memory”**

If the TRIG is turned from OFF to ON or the data corresponding to the trigger is changed, the next direct data is saved in the buffer memory. When the data during operation is completed, operation of the buffer memory is automatically started. One direct data can be stored in the buffer memory.

If the next direct data is written to the buffer memory, the DCMD-FULL output is turned ON.

During stop or continuous operation, if “Buffer memory” is specified, the data is not stored in the buffer memory and it is rewritten to the next direct data immediately.

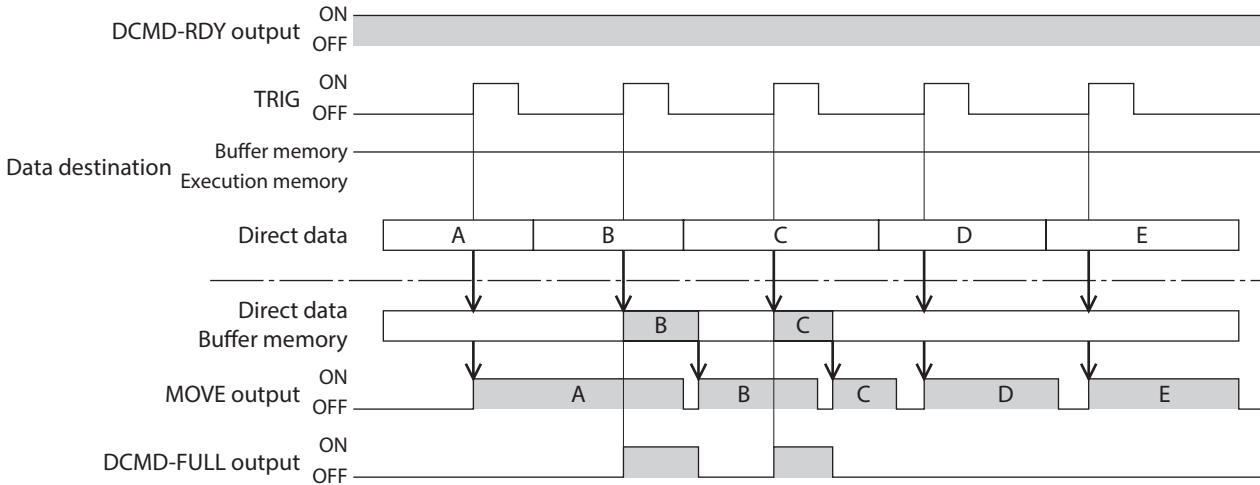

memo The direct data cannot be written to the buffer memory while the DCMD-FULL output is being ON.

6-3 Operation example

A condition to execute direct data operation can be selected from the ON edge or ON level of TRIG of fixed I/O (IN). A condition can be selected with the TRIG-MODE of fixed I/O (IN).

Note Before operating the motor, check the condition of the surrounding area to ensure safety.

■ When direct data operation is executed at ON edge of TRIG

As an example, this section explains how to perform the following direct data operation.

● Setting example

- Operation type: Incremental positioning (based on command position)
- Position: 5,000 steps
- Operating speed: 1,000 Hz
- Starting/changing speed rate: 1,000 kHz/s
- Stopping deceleration: 1,000 kHz/s
- Operating current: 100 %
- Forwarding destination: Execution memory

● Operation processing flow

Descriptions are given using the scanner as the subject.

1. Check the DCMD-RDY has been turned ON.
2. Set the following data.

- Output (scanner → driver)

| Byte | Description | Setting value | Note |
|----------|--|---------------|---|
| 4, 5 | TRIG-MODE [bit 9 of fixed I/O (IN)] | 0 | Start at ON edge |
| 6, 7 | Direct data operation operation type | 2 | Incremental positioning (based on command position) |
| 8 to 11 | Direct data operation position | 5,000 | 5,000 steps |
| 12 to 15 | Direct data operation operating speed | 1,000 | 1,000 Hz |
| 16 to 19 | Direct data operation starting/changing rate | 1,000,000 | 1,000 kHz/s |
| 20 to 23 | Direct data operation stopping deceleration | 1,000,000 | 1,000 kHz/s |
| 24, 25 | Direct data operation operating current | 1,000 | 100.0 % |
| 26, 27 | Direct data operation forwarding destination | 0 | Execution memory |

3. Turn the TRIG ON.
Direct data operation is started.
4. Check the TRIG_R has been turned ON, and turn the TRIG OFF.

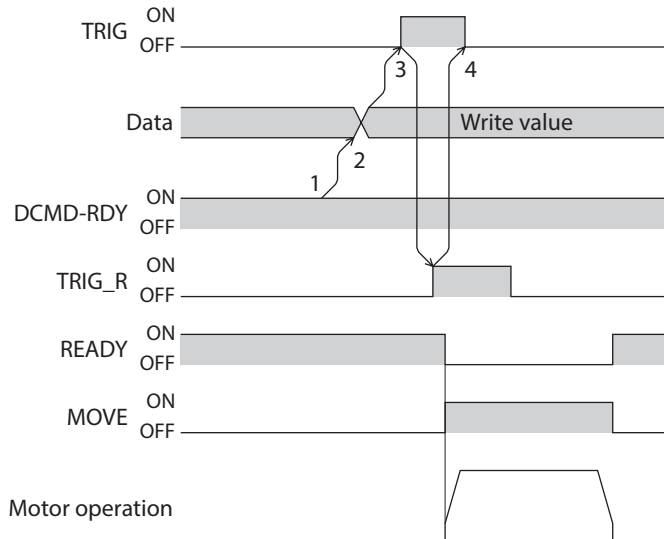

■ When direct data operation is executed at ON level of TRIG

This section explains how to execute the following direct data operation with setting the trigger to “position.” Set the trigger with the “Direct data operation trigger setting” parameter.

● Setting example

- Operation 1
Position: 7,000 steps
- Operation 2
Position: 3,000 steps
- Other settings

| Description | Setting value |
|------------------------|---|
| Operation type | Incremental positioning (based on command position) |
| Operating speed | 1,000 Hz |
| Starting/changing rate | 1,000 kHz/s |

| Description | Setting value |
|------------------------|------------------|
| Stopping deceleration | 1,000 kHz/s |
| Operating current | 100 % |
| Forwarding destination | Execution memory |

● Operation processing flow

Descriptions are given using the scanner as the subject.

1. Set the following parameters to turn the WR-REQ ON.
The parameter information is set to the driver. When the setting is completed, the WR-END is turned ON.

● Output (scanner → driver)

| Byte | Description | Setting value | Note |
|----------|--------------------|---------------|---|
| 34, 35 | Write parameter ID | 24852 | Parameter ID of “Direct data operation trigger setting” |
| 36 to 39 | Write data | –5 | Position |

2. Turn the WR-REQ OFF.
The WR-END is returned to OFF.
3. Check the DCMD-RDY has been turned ON.
4. Set the following data.

● Output (scanner → driver)

| Byte | Description | Setting value | Note |
|----------|--|---------------|---|
| 4, 5 | TRIG-MODE [bit 9 of fixed I/O (IN)] | 1 | Start at ON level |
| 6, 7 | Direct data operation operation type | 2 | Incremental positioning (based on command position) |
| 8 to 11 | Direct data operation position | 7,000 | 7,000 steps |
| 12 to 15 | Direct data operation operating speed | 1,000 | 1,000 Hz |
| 16 to 19 | Direct data operation starting/changing rate | 1,000,000 | 1,000 kHz/s |
| 20 to 23 | Direct data operation stopping deceleration | 1,000,000 | 1,000 kHz/s |
| 24, 25 | Direct data operation operating current | 1,000 | 100 % |
| 26, 27 | Direct data operation forwarding destination | 0 | Execution memory |

5. Turn the TRIG ON.
Direct data operation of the operation 1 is started.
6. Check the operation 1 is completed, and set the following data.
Direct data operation of the operation 2 is started.

● Output (scanner → driver)

| Byte | Description | Setting value | Note |
|---------|--------------------------------|---------------|-------------|
| 8 to 11 | Direct data operation position | 3,000 | 3,000 steps |



- To execute direct data operation of the operation 2, set a different value from the operation 1 in the “position” of the operation 2.
- If a value other than the “position” is changed, direct data operation of the operation 2 will not be executed.

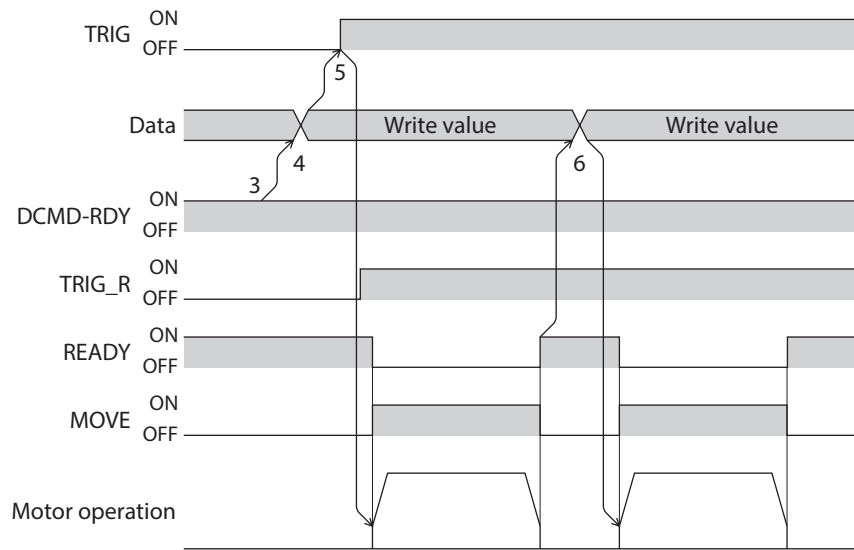

4 Parameter ID lists

This part describes the parameter ID lists to be set via EtherNet/IP.
Data and parameters described here can also be set using the MEXE02 software.

◆ Table of contents

| | | | | |
|----------|--|-----------|--|--|
| 1 | Timing for parameter to update | 68 | | |
| 2 | Maintenance commands..... | 69 | | |
| 3 | Monitor commands..... | 70 | | |
| 4 | Operation data R/W commands | 76 | | |
| | 4-1 Base address of each operation data number..... | 76 | | |
| | 4-2 Parameter ID..... | 78 | | |
| | 4-3 Setting example..... | 79 | | |
| 5 | Operation I/O event R/W commands | 80 | | |
| | 5-1 Base address of operation I/O event..... | 80 | | |
| | 5-2 Parameter ID for operation I/O event R/W command..... | 80 | | |
| 6 | Protect release commands | 81 | | |
| 7 | Extended operation data setting R/W command..... | 82 | | |
| 8 | Parameter R/W commands | 83 | | |
| | 8-1 Driver action simulation setting parameter..... | 83 | | |
| | 8-2 Base setting parameter..... | 83 | | |
| | 8-3 Coordinate parameters..... | 84 | | |
| | 8-4 Operation parameters..... | 84 | | |
| | 8-5 Direct data operation parameters | 84 | | |
| | 8-6 ABZO sensor setting parameters | 85 | | |
| | 8-7 Mechanism settings parameters..... | 85 | | |
| | 8-8 Initial coordinate generation & wrap coordinate parameters..... | 85 | | |
| | 8-9 JOG/HOME/ZHOME operation information setting parameters | 86 | | |
| | 8-10 Alarm setting parameters..... | 87 | | |
| | 8-11 Information setting parameters..... | 87 | | |
| | 8-12 I/O parameters..... | 89 | | |
| | 8-13 Direct I/O setting parameters..... | 92 | | |
| | 8-14 Remote I/O setting parameters | 92 | | |
| | 8-15 Virtual input parameters..... | 93 | | |
| | 8-16 User output setting parameters..... | 94 | | |
| | 8-17 Driver mode setting parameters..... | 94 | | |
| | 8-18 EtherNet/IP communication setting parameters..... | 94 | | |
| 9 | I/O signals assignment list | 96 | | |
| | 9-1 Input signals | 96 | | |
| | 9-2 Output signals | 97 | | |

1 Timing for parameter to update

All data used with the driver is 32 bits wide.

Parameters are saved in the RAM or non-volatile memory of the driver. Parameters stored in the RAM are erased once the main power supply and control power supply are shut off, however, those stored in non-volatile memory are retained even if these power supplies are shut off.

When the control power supply of the driver is turned on, the parameters stored in the non-volatile memory are transferred to the RAM, and recalculation and setup for the parameters are executed in the RAM.

Parameters having set via Implicit communication are saved in the RAM. To save the parameters stored in the RAM to the non-volatile memory, execute the "Write batch NV memory" of the maintenance command.

When a parameter is changed, the timing to update the new value varies depending on the parameter. Refer to "Notation rules" for details about the update timing.

Note Do not shut off the main power supply and the control power supply while writing the data to the non-volatile memory, and also do not shut off for five seconds after the completion of writing the data. Doing so may abort the data write and cause an alarm of EEPROM error (alarm code 41h) to generate.

- memo**
- Parameters set via Implicit communication are saved in the RAM. For parameters that requires to turn on the main power supply and the control power supply again for updating, be sure to save them in the non-volatile memory before turning off the power supplies.
 - The non-volatile memory can be rewritten approximately 100,000 times.

■ Notation rules

● Timing to update

In this part, each update timing is represented in an alphabet.

| Notation | Update timing | Description |
|----------|---|---|
| A | Immediately | Recalculation and setup are immediately executed when the parameter is written. |
| B | After operation stop | Recalculation and setup are executed when the operation is stopped. |
| C | After executing Configuration | Recalculation and setup are executed after Configuration is executed or the main power supply and control power supply are turned on again. |
| D | After turning on the main power supply and control power supply again | Recalculation and setup are executed after the main power supply and control power supply are turned on again. |

● READ and WRITE

READ/WRITE may be represented as follows in this manual.

| Notation | Description |
|----------|-------------|
| R | READ |
| W | WRITE |
| R/W | READ/WRITE |

2 Maintenance commands

Maintenance commands are used to execute the alarm reset, clear latch information, batch processing of the non-volatile memory and others.

Refer to the **AZ Series OPERATING MANUAL Function Edition** for details about parameters. When checking the **AZ Series OPERATING MANUAL Function Edition**, use the parameter name instead of the parameter ID.

Note The maintenance commands include processing in which the memory is operated, such as batch processing of the non-volatile memory and P-PRESET. Exercise caution not to execute them unnecessarily in succession.

| Parameter ID | | Name | Setting range | Initial value | | |
|--------------|-------|--|---------------|---------------|--------------------------------|-----------------|
| Dec | Hex | | | | | |
| 192 | 00C0h | Alarm reset | - | - | | |
| 194 | 00C2h | Clear alarm history | | | | |
| 197 | 00C5h | P-PRESET execution | | | | |
| 198 | 00C6h | Configuration | | | | |
| 199 | 00C7h | Batch data initialization (excluding communication parameters) | | | | |
| 200 | 00C8h | Read batch NV memory | | | | |
| 201 | 00C9h | Write batch NV memory | | | | |
| 202 | 00CAh | All data batch initialization (including communication parameters) | | | | |
| 203 | 00CBh | Read from backup | | | | |
| 204 | 00CCh | Write to backup | | | | |
| 205 | 00CDh | Clear latch information | | | | |
| 206 | 00CEh | Clear sequence history | | | | |
| 207 | 00CFh | Clear tripmeter | | | | |
| 209 | 00D1h | ZSG-PRESET | | | | |
| 210 | 00D2h | Clear ZSG-PRESET | | | | |
| 211 | 00D3h | Clear information | | | | |
| 212 | 00D4h | Clear information history | | | | |
| 213 | 00D5h | Alarm history details | | | 1 to 10: Alarm history 1 to 10 | 0: Not selected |

■ Configuration

Configuration can be executed when all of the following conditions are satisfied.

- An alarm is not being generated.
- The motor is not operating.
- I/O test, teaching, remote operation, teaching, and downloading are not executed with the **MEXE02**.

The table below shows the driver status before and after Configuration is executed.

| Item | Configuration is ready to execute | Configuration is being executed | After configuration is executed |
|-----------------------|-----------------------------------|---------------------------------|---------------------------------|
| PWR/ALM LED | Green light | Blinking blue | Based on the driver condition. |
| Electromagnetic brake | Hold/release | Hold | |
| Motor excitation | Excitation/non-excitation | Non-excitation | |
| Output signal | Enable | Disable | Enable |
| Input signal | Enable | Disable | Enable |

memo The correct monitor value may not be returned even if monitoring is executed during configuration.

3 Monitor commands

Monitor commands are used to monitor the command position, command speed, alarm and information history and others. All commands are used for read (READ).

Refer to the **AZ** Series OPERATING MANUAL Function Edition for details about parameters. When checking the **AZ** Series OPERATING MANUAL Function Edition, use the parameter name instead of the parameter ID.

| Parameter ID | | Name |
|--------------|-------|--|
| Dec | Hex | |
| 64 | 0040h | Present alarm |
| 65 | 0041h | Alarm history 1 |
| 66 | 0042h | Alarm history 2 |
| 67 | 0043h | Alarm history 3 |
| 68 | 0044h | Alarm history 4 |
| 69 | 0045h | Alarm history 5 |
| 70 | 0046h | Alarm history 6 |
| 71 | 0047h | Alarm history 7 |
| 72 | 0048h | Alarm history 8 |
| 73 | 0049h | Alarm history 9 |
| 74 | 004Ah | Alarm history 10 |
| 97 | 0061h | Present selected data number |
| 98 | 0062h | Present operation data number |
| 99 | 0063h | Command position |
| 100 | 0064h | Command speed (r/min) |
| 101 | 0065h | Command speed (Hz) |
| 102 | 0066h | Feedback position |
| 103 | 0067h | Feedback speed (r/min) |
| 104 | 0068h | Feedback speed (Hz) |
| 105 | 0069h | Remaining dwell time |
| 106 | 006Ah | Direct I/O |
| 107 | 006Bh | Torque monitor (1=0.1 %) |
| 109 | 006Dh | Cumulative load monitor |
| 111 | 006Fh | Target position |
| 112 | 0070h | Next number |
| 113 | 0071h | Loop origin number |
| 114 | 0072h | Loop count |
| 115 | 0073h | Event monitor command position (NEXT) |
| 116 | 0074h | Event monitor feedback position (NEXT) |
| 117 | 0075h | Event monitor command position (JUMP0 – Low event) |
| 118 | 0076h | Event monitor feedback position (JUMP0 – Low event) |
| 119 | 0077h | Event monitor command position (JUMP1 – High event) |
| 120 | 0078h | Event monitor feedback position (JUMP1 – High event) |
| 121 | 0079h | Event monitor command position (Operation stop) |
| 122 | 007Ah | Event monitor feedback position (Operation stop) |
| 123 | 007Bh | Information |
| 124 | 007Ch | Driver temperature (1=0.1 °C) |
| 125 | 007Dh | Motor temperature (1=0.1 °C) |
| 126 | 007Eh | Odometer (1=0.1 kRev) |
| 127 | 007Fh | Tripmeter (1=0.1 kRev) |

| Parameter ID | | Name |
|--------------|-------|---|
| Dec | Hex | |
| 128 | 0080h | Sequence history 1 |
| 129 | 0081h | Sequence history 2 |
| 130 | 0082h | Sequence history 3 |
| 131 | 0083h | Sequence history 4 |
| 132 | 0084h | Sequence history 5 |
| 133 | 0085h | Sequence history 6 |
| 134 | 0086h | Sequence history 7 |
| 135 | 0087h | Sequence history 8 |
| 136 | 0088h | Sequence history 9 |
| 137 | 0089h | Sequence history 10 |
| 138 | 008Ah | Sequence history 11 |
| 139 | 008Bh | Sequence history 12 |
| 140 | 008Ch | Sequence history 13 |
| 141 | 008Dh | Sequence history 14 |
| 142 | 008Eh | Sequence history 15 |
| 143 | 008Fh | Sequence history 16 |
| 144 | 0090h | Feedback position 32-bit counter |
| 145 | 0091h | Command position 32-bit counter |
| 146 | 0092h | CST operating current (1=0.1 %) |
| 147 | 0093h | Loop count buffer |
| 160 | 00A0h | Main power supply count |
| 161 | 00A1h | Main power supply time (min) |
| 162 | 00A2h | Control power supply count *1 |
| 163 | 00A3h | Inverter voltage (1=0.1 V) |
| 164 | 00A4h | Main power supply voltage (1=0.1 V) |
| 167 | 00A7h | IP ADDR SW *2 |
| 169 | 00A9h | Elapsed time from BOOT (ms) |
| 184 | 00B8h | I/O status 1 |
| 185 | 00B9h | I/O status 2 |
| 186 | 00BAh | I/O status 3 |
| 187 | 00BBh | I/O status 4 |
| 188 | 00BCh | I/O status 5 |
| 189 | 00BDh | I/O status 6 |
| 190 | 00BEh | I/O status 7 |
| 191 | 00BFh | I/O status 8 |
| 1280 | 0500h | Alarm history details (Alarm code) |
| 1281 | 0501h | Alarm history details (Sub code) |
| 1282 | 0502h | Alarm history details (Driver temperature) |
| 1283 | 0503h | Alarm history details (Motor temperature) |
| 1284 | 0504h | Alarm history details (Inverter voltage) |
| 1285 | 0505h | Alarm history details (Physical I/O input) |
| 1286 | 0506h | Alarm history details (R-I/O output) |
| 1287 | 0507h | Alarm history details (Operation information 0) |
| 1288 | 0508h | Alarm history details (Operation information 1) |
| 1289 | 0509h | Alarm history details (Feedback position) |
| 1290 | 050Ah | Alarm history details (Elapsed time from Boot) [ms] |
| 1291 | 050Bh | Alarm history details (Elapsed time from starting operation) [ms] |

| Parameter ID | | Name |
|--------------|-------|---|
| Dec | Hex | |
| 1292 | 050Ch | Alarm history details (Main power supply time) [min] |
| 1296 | 0510h | Information history 1 |
| 1297 | 0511h | Information history 2 |
| 1298 | 0512h | Information history 3 |
| 1299 | 0513h | Information history 4 |
| 1300 | 0514h | Information history 5 |
| 1301 | 0515h | Information history 6 |
| 1302 | 0516h | Information history 7 |
| 1303 | 0517h | Information history 8 |
| 1304 | 0518h | Information history 9 |
| 1305 | 0519h | Information history 10 |
| 1306 | 051Ah | Information history 11 |
| 1307 | 051Bh | Information history 12 |
| 1308 | 051Ch | Information history 13 |
| 1309 | 051Dh | Information history 14 |
| 1310 | 051Eh | Information history 15 |
| 1311 | 051Fh | Information history 16 |
| 1312 | 0520h | Information time history 1 (ms) |
| 1313 | 0521h | Information time history 2 (ms) |
| 1314 | 0522h | Information time history 3 (ms) |
| 1315 | 0523h | Information time history 4 (ms) |
| 1316 | 0524h | Information time history 5 (ms) |
| 1317 | 0525h | Information time history 6 (ms) |
| 1318 | 0526h | Information time history 7 (ms) |
| 1319 | 0527h | Information time history 8 (ms) |
| 1320 | 0528h | Information time history 9 (ms) |
| 1321 | 0529h | Information time history 10 (ms) |
| 1322 | 052Ah | Information time history 11 (ms) |
| 1323 | 052Bh | Information time history 12 (ms) |
| 1324 | 052Ch | Information time history 13 (ms) |
| 1325 | 052Dh | Information time history 14 (ms) |
| 1326 | 052Eh | Information time history 15 (ms) |
| 1327 | 052Fh | Information time history 16 (ms) |
| 1472 | 05C0h | Latch monitor status (NEXT) |
| 1473 | 05C1h | Latch monitor command position (NEXT) |
| 1474 | 05C2h | Latch monitor feedback position (NEXT) |
| 1475 | 05C3h | Latch monitor target position (NEXT) |
| 1476 | 05C4h | Latch monitor operation number (NEXT) |
| 1477 | 05C5h | Latch monitor number of loop (NEXT) |
| 1480 | 05C8h | Latch monitor status (I/O event – Low event) |
| 1481 | 05C9h | Latch monitor command position (I/O event – Low event) |
| 1482 | 05CAh | Latch monitor feedback position (I/O event – Low event) |
| 1483 | 05CBh | Latch monitor target position (I/O event – Low event) |
| 1484 | 05CCh | Latch monitor operation number (I/O event – Low event) |
| 1485 | 05CDh | Latch monitor number of loop (I/O event – Low event) |
| 1488 | 05D0h | Latch monitor status (I/O event – High event) |
| 1489 | 05D1h | Latch monitor command position (I/O event – High event) |

| Parameter ID | | Name |
|--------------|-------|--|
| Dec | Hex | |
| 1490 | 05D2h | Latch monitor feedback position (I/O event – High event) |
| 1491 | 05D3h | Latch monitor target position (I/O event – High event) |
| 1492 | 05D4h | Latch monitor operation number (I/O event – High event) |
| 1493 | 05D5h | Latch monitor number of loop (I/O event – High event) |
| 1496 | 05D8h | Latch monitor status (Operation stop) |
| 1497 | 05D9h | Latch monitor command position (Operation stop) |
| 1498 | 05DAh | Latch monitor feedback position (Operation stop) |
| 1499 | 05DBh | Latch monitor target position (Operation stop) |
| 1500 | 05DCh | Latch monitor operation number (Operation stop) |
| 1501 | 05DDh | Latch monitor number of loop (Operation stop) |

*1 It will be the number of times the main power supply is turned on if the control power supply is not connected.

*2 It is not described on the **AZ** Series OPERATING MANUAL Function Edition. It indicates the input status of the IP address setting switch (IP ADDR ×1).

■ Direct I/O

The arrangement of bits for direct input is indicated.

| | | | | | | | |
|---------|---------|---------|---------|--------|--------|--------|--------|
| Bit 31 | Bit 30 | Bit 29 | Bit 28 | Bit 27 | Bit 26 | Bit 25 | Bit 24 |
| – | – | – | – | – | – | – | – |
| Bit 23 | Bit 22 | Bit 21 | Bit 20 | Bit 19 | Bit 18 | Bit 17 | Bit 16 |
| – | – | – | – | – | – | – | – |
| Bit 15 | Bit 14 | Bit 13 | Bit 12 | Bit 11 | Bit 10 | Bit 9 | Bit 8 |
| VIR-IN3 | VIR-IN2 | VIR-IN1 | VIR-IN0 | – | – | – | – |
| Bit 7 | Bit 6 | Bit 5 | Bit 4 | Bit 3 | Bit 2 | Bit 1 | Bit 0 |
| – | – | – | – | – | – | IN1 | IN0 |

■ I/O status

The arrangement of bits for internal I/O is indicated.

● Input signals

| Parameter ID | Description | | | | | | | |
|----------------|-------------|----------|-----------|----------|----------|----------|----------|---------|
| 184 (00B8h) | Bit 31 | Bit 30 | Bit 29 | Bit 28 | Bit 27 | Bit 26 | Bit 25 | Bit 24 |
| | SLIT | HOMES | RV-LS | FW-LS | RV-BLK | FW-BLK | – | – |
| | Bit 23 | Bit 22 | Bit 21 | Bit 20 | Bit 19 | Bit 18 | Bit 17 | Bit 16 |
| | SPD-LMT | CRNT-LMT | T-MODE | – | – | CCM | – | HMI |
| | Bit 15 | Bit 14 | Bit 13 | Bit 12 | Bit 11 | Bit 10 | Bit 9 | Bit 8 |
| | – | INFO-CLR | LAT-CLR | – | – | EL-PRST | P-PRESET | ALM-RST |
| | Bit 7 | Bit 6 | Bit 5 | Bit 4 | Bit 3 | Bit 2 | Bit 1 | Bit 0 |
| BREAK-ATSQ | PAUSE | STOP | STOP-COFF | CLR | C-ON | FREE | Not used | |
| 185 (00B9h) | Bit 31 | Bit 30 | Bit 29 | Bit 28 | Bit 27 | Bit 26 | Bit 25 | Bit 24 |
| | – | – | RV-PSH | FW-PSH | RV-SPD | FW-SPD | RV-POS | FW-POS |
| | Bit 23 | Bit 22 | Bit 21 | Bit 20 | Bit 19 | Bit 18 | Bit 17 | Bit 16 |
| | RV-JOG-C | FW-JOG-C | RV-JOG-P | FW-JOG-P | RV-JOG-H | FW-JOG-H | RV-JOG | FW-JOG |
| | Bit 15 | Bit 14 | Bit 13 | Bit 12 | Bit 11 | Bit 10 | Bit 9 | Bit 8 |
| | D-SEL7 | D-SEL6 | D-SEL5 | D-SEL4 | D-SEL3 | D-SEL2 | D-SEL1 | D-SEL0 |
| | Bit 7 | Bit 6 | Bit 5 | Bit 4 | Bit 3 | Bit 2 | Bit 1 | Bit 0 |
| – | – | ZHOME | HOME | NEXT | – | SSTART | START | |
| 186 (00BAh) | Bit 31 | Bit 30 | Bit 29 | Bit 28 | Bit 27 | Bit 26 | Bit 25 | Bit 24 |
| | R15 | R14 | R13 | R12 | R11 | R10 | R9 | R8 |
| | Bit 23 | Bit 22 | Bit 21 | Bit 20 | Bit 19 | Bit 18 | Bit 17 | Bit 16 |
| | R7 | R6 | R5 | R4 | R3 | R2 | R1 | R0 |
| | Bit 15 | Bit 14 | Bit 13 | Bit 12 | Bit 11 | Bit 10 | Bit 9 | Bit 8 |
| | – | – | – | – | TEACH | – | – | – |
| | Bit 7 | Bit 6 | Bit 5 | Bit 4 | Bit 3 | Bit 2 | Bit 1 | Bit 0 |
| M7 | M6 | M5 | M4 | M3 | M2 | M1 | M0 | |
| 187 (00BBh) | Bit 31 | Bit 30 | Bit 29 | Bit 28 | Bit 27 | Bit 26 | Bit 25 | Bit 24 |
| | – | – | – | – | – | – | – | – |
| | Bit 23 | Bit 22 | Bit 21 | Bit 20 | Bit 19 | Bit 18 | Bit 17 | Bit 16 |
| | – | – | – | – | – | – | – | – |
| | Bit 15 | Bit 14 | Bit 13 | Bit 12 | Bit 11 | Bit 10 | Bit 9 | Bit 8 |
| | – | – | – | – | – | – | – | – |
| | Bit 7 | Bit 6 | Bit 5 | Bit 4 | Bit 3 | Bit 2 | Bit 1 | Bit 0 |
| – | – | – | – | – | – | – | – | |

● Output signals

| Parameter ID | Description | | | | | | | |
|----------------|-------------|------------|-------------|-------------|-------------|-------------|------------|------------|
| 188 (00BCh) | Bit 31 | Bit 30 | Bit 29 | Bit 28 | Bit 27 | Bit 26 | Bit 25 | Bit 24 |
| | MAREA | – | TIM | RND-ZERO | ZSG | RV-SLS | FW-SLS | RND-OVF |
| | Bit 23 | Bit 22 | Bit 21 | Bit 20 | Bit 19 | Bit 18 | Bit 17 | Bit 16 |
| | ORGN-STLD | PRST-STLD | PRST-DIS | – | – | ELPRST-MON | ABSPEN | HOME-END |
| | Bit 15 | Bit 14 | Bit 13 | Bit 12 | Bit 11 | Bit 10 | Bit 9 | Bit 8 |
| | AUTO-CD | CRNT | VA | TLC | – | IN-POS | – | SYS-BSY |
| | Bit 7 | Bit 6 | Bit 5 | Bit 4 | Bit 3 | Bit 2 | Bit 1 | Bit 0 |
| INFO | MOVE | – | READY | SYS-RDY | ALM-B | ALM-A | CONST-OFF | |
| 189 (00BDh) | Bit 31 | Bit 30 | Bit 29 | Bit 28 | Bit 27 | Bit 26 | Bit 25 | Bit 24 |
| | – | – | – | – | – | – | – | – |
| | Bit 23 | Bit 22 | Bit 21 | Bit 20 | Bit 19 | Bit 18 | Bit 17 | Bit 16 |
| | – | – | USR-OUT1 | USR-OUT0 | – | – | – | – |
| | Bit 15 | Bit 14 | Bit 13 | Bit 12 | Bit 11 | Bit 10 | Bit 9 | Bit 8 |
| | – | – | – | – | – | – | MBC | MPS |
| | Bit 7 | Bit 6 | Bit 5 | Bit 4 | Bit 3 | Bit 2 | Bit 1 | Bit 0 |
| AREA7 | AREA6 | AREA5 | AREA4 | AREA3 | AREA2 | AREA1 | AREA0 | |
| 190 (00BEh) | Bit 31 | Bit 30 | Bit 29 | Bit 28 | Bit 27 | Bit 26 | Bit 25 | Bit 24 |
| | D-END7 | D-END6 | D-END5 | D-END4 | D-END3 | D-END2 | D-END1 | D-END0 |
| | Bit 23 | Bit 22 | Bit 21 | Bit 20 | Bit 19 | Bit 18 | Bit 17 | Bit 16 |
| | M-ACT7 | M-ACT6 | M-ACT5 | M-ACT4 | M-ACT3 | M-ACT2 | M-ACT1 | M-ACT0 |
| | Bit 15 | Bit 14 | Bit 13 | Bit 12 | Bit 11 | Bit 10 | Bit 9 | Bit 8 |
| | M-CHG | – | DCMD-FULL | DCMD-RDY | – | NEXT-LAT | JUMP1-LAT | JUMP0-LAT |
| | Bit 7 | Bit 6 | Bit 5 | Bit 4 | Bit 3 | Bit 2 | Bit 1 | Bit 0 |
| DELAY-BSY | SEQ-BSY | PAUSE-BSY | OPE-BSY | – | – | SPD-LMTD | CRNT-LMTD | |
| 191 (00BFh) | Bit 31 | Bit 30 | Bit 29 | Bit 28 | Bit 27 | Bit 26 | Bit 25 | Bit 24 |
| | INFO-RBT | INFO-CFG | INFO-IOTEST | INFO-DSLMTD | – | – | – | – |
| | Bit 23 | Bit 22 | Bit 21 | Bit 20 | Bit 19 | Bit 18 | Bit 17 | Bit 16 |
| | – | – | INFO-ODO | INFO-TRIP | INFO-CULD1 | INFO-CULD0 | INFO-RV-OT | INFO-FW-OT |
| | Bit 15 | Bit 14 | Bit 13 | Bit 12 | Bit 11 | Bit 10 | Bit 9 | Bit 8 |
| | INFO-NET-E | INFO-RND-E | INFO-EGR-E | – | INFO-PR-REQ | INFO-ZHOME | INFO-START | INFO-SPD |
| | Bit 7 | Bit 6 | Bit 5 | Bit 4 | Bit 3 | Bit 2 | Bit 1 | Bit 0 |
| – | INFO-OLTIME | INFO-UVOLT | INFO-OVOLT | INFO-MTRTMP | INFO-DRVTMP | INFO-POSERR | INFO-USRIO | |

4 Operation data R/W commands

This is a method in which the parameter ID (base address) of the base operation data number is specified to Input data.

Refer to "4-3 Setting example" on p.79 for how to use the base address.

4-1 Base address of each operation data number

| Base address | | Operation data | Base address | | Operation data | Base address | | Operation data | Base address | | Operation data |
|--------------|-------|----------------|--------------|-------|----------------|--------------|-------|----------------|--------------|-------|----------------|
| Dec | Hex | | Dec | Hex | | Dec | Hex | | Dec | Hex | |
| 3072 | 0C00h | No.0 | 4288 | 10C0h | No.38 | 5504 | 1580h | No.76 | 6720 | 1A40h | No.114 |
| 3104 | 0C20h | No.1 | 4320 | 10E0h | No.39 | 5536 | 15A0h | No.77 | 6752 | 1A60h | No.115 |
| 3136 | 0C40h | No.2 | 4352 | 1100h | No.40 | 5568 | 15C0h | No.78 | 6784 | 1A80h | No.116 |
| 3168 | 0C60h | No.3 | 4384 | 1120h | No.41 | 5600 | 15E0h | No.79 | 6816 | 1AA0h | No.117 |
| 3200 | 0C80h | No.4 | 4416 | 1140h | No.42 | 5632 | 1600h | No.80 | 6848 | 1AC0h | No.118 |
| 3232 | 0CA0h | No.5 | 4448 | 1160h | No.43 | 5664 | 1620h | No.81 | 6880 | 1AE0h | No.119 |
| 3264 | 0CC0h | No.6 | 4480 | 1180h | No.44 | 5696 | 1640h | No.82 | 6912 | 1B00h | No.120 |
| 3296 | 0CE0h | No.7 | 4512 | 11A0h | No.45 | 5728 | 1660h | No.83 | 6944 | 1B20h | No.121 |
| 3328 | 0D00h | No.8 | 4544 | 11C0h | No.46 | 5760 | 1680h | No.84 | 6976 | 1B40h | No.122 |
| 3360 | 0D20h | No.9 | 4576 | 11E0h | No.47 | 5792 | 16A0h | No.85 | 7008 | 1B60h | No.123 |
| 3392 | 0D40h | No.10 | 4608 | 1200h | No.48 | 5824 | 16C0h | No.86 | 7040 | 1B80h | No.124 |
| 3424 | 0D60h | No.11 | 4640 | 1220h | No.49 | 5856 | 16E0h | No.87 | 7072 | 1BA0h | No.125 |
| 3456 | 0D80h | No.12 | 4672 | 1240h | No.50 | 5888 | 1700h | No.88 | 7104 | 1BC0h | No.126 |
| 3488 | 0DA0h | No.13 | 4704 | 1260h | No.51 | 5920 | 1720h | No.89 | 7136 | 1BE0h | No.127 |
| 3520 | 0DC0h | No.14 | 4736 | 1280h | No.52 | 5952 | 1740h | No.90 | 7168 | 1C00h | No.128 |
| 3552 | 0DE0h | No.15 | 4768 | 12A0h | No.53 | 5984 | 1760h | No.91 | 7200 | 1C20h | No.129 |
| 3584 | 0E00h | No.16 | 4800 | 12C0h | No.54 | 6016 | 1780h | No.92 | 7232 | 1C40h | No.130 |
| 3616 | 0E20h | No.17 | 4832 | 12E0h | No.55 | 6048 | 17A0h | No.93 | 7264 | 1C60h | No.131 |
| 3648 | 0E40h | No.18 | 4864 | 1300h | No.56 | 6080 | 17C0h | No.94 | 7296 | 1C80h | No.132 |
| 3680 | 0E60h | No.19 | 4896 | 1320h | No.57 | 6112 | 17E0h | No.95 | 7328 | 1CA0h | No.133 |
| 3712 | 0E80h | No.20 | 4928 | 1340h | No.58 | 6144 | 1800h | No.96 | 7360 | 1CC0h | No.134 |
| 3744 | 0EA0h | No.21 | 4960 | 1360h | No.59 | 6176 | 1820h | No.97 | 7392 | 1CE0h | No.135 |
| 3776 | 0EC0h | No.22 | 4992 | 1380h | No.60 | 6208 | 1840h | No.98 | 7424 | 1D00h | No.136 |
| 3808 | 0EE0h | No.23 | 5024 | 13A0h | No.61 | 6240 | 1860h | No.99 | 7456 | 1D20h | No.137 |
| 3840 | 0F00h | No.24 | 5056 | 13C0h | No.62 | 6272 | 1880h | No.100 | 7488 | 1D40h | No.138 |
| 3872 | 0F20h | No.25 | 5088 | 13E0h | No.63 | 6304 | 18A0h | No.101 | 7520 | 1D60h | No.139 |
| 3904 | 0F40h | No.26 | 5120 | 1400h | No.64 | 6336 | 18C0h | No.102 | 7552 | 1D80h | No.140 |
| 3936 | 0F60h | No.27 | 5152 | 1420h | No.65 | 6368 | 18E0h | No.103 | 7584 | 1DA0h | No.141 |
| 3968 | 0F80h | No.28 | 5184 | 1440h | No.66 | 6400 | 1900h | No.104 | 7616 | 1DC0h | No.142 |
| 4000 | 0FA0h | No.29 | 5216 | 1460h | No.67 | 6432 | 1920h | No.105 | 7648 | 1DE0h | No.143 |
| 4032 | 0FC0h | No.30 | 5248 | 1480h | No.68 | 6464 | 1940h | No.106 | 7680 | 1E00h | No.144 |
| 4064 | 0FE0h | No.31 | 5280 | 14A0h | No.69 | 6496 | 1960h | No.107 | 7712 | 1E20h | No.145 |
| 4096 | 1000h | No.32 | 5312 | 14C0h | No.70 | 6528 | 1980h | No.108 | 7744 | 1E40h | No.146 |
| 4128 | 1020h | No.33 | 5344 | 14E0h | No.71 | 6560 | 19A0h | No.109 | 7776 | 1E60h | No.147 |
| 4160 | 1040h | No.34 | 5376 | 1500h | No.72 | 6592 | 19C0h | No.110 | 7808 | 1E80h | No.148 |
| 4192 | 1060h | No.35 | 5408 | 1520h | No.73 | 6624 | 19E0h | No.111 | 7840 | 1EA0h | No.149 |
| 4224 | 1080h | No.36 | 5440 | 1540h | No.74 | 6656 | 1A00h | No.112 | 7872 | 1EC0h | No.150 |
| 4256 | 10A0h | No.37 | 5472 | 1560h | No.75 | 6688 | 1A20h | No.113 | 7904 | 1EE0h | No.151 |

| Base address | | Operation data | Base address | | Operation data | Base address | | Operation data | Base address | | Operation data |
|--------------|-------|----------------|--------------|-------|----------------|--------------|-------|----------------|--------------|-------|----------------|
| Dec | Hex | | Dec | Hex | | Dec | Hex | | Dec | Hex | |
| 7936 | 1F00h | No.152 | 8768 | 2240h | No.178 | 9600 | 2580h | No.204 | 10432 | 28C0h | No.230 |
| 7968 | 1F20h | No.153 | 8800 | 2260h | No.179 | 9632 | 25A0h | No.205 | 10464 | 28E0h | No.231 |
| 8000 | 1F40h | No.154 | 8832 | 2280h | No.180 | 9664 | 25C0h | No.206 | 10496 | 2900h | No.232 |
| 8032 | 1F60h | No.155 | 8864 | 22A0h | No.181 | 9696 | 25E0h | No.207 | 10528 | 2920h | No.233 |
| 8064 | 1F80h | No.156 | 8896 | 22C0h | No.182 | 9728 | 2600h | No.208 | 10560 | 2940h | No.234 |
| 8096 | 1FA0h | No.157 | 8928 | 22E0h | No.183 | 9760 | 2620h | No.209 | 10592 | 2960h | No.235 |
| 8128 | 1FC0h | No.158 | 8960 | 2300h | No.184 | 9792 | 2640h | No.210 | 10624 | 2980h | No.236 |
| 8160 | 1FE0h | No.159 | 8992 | 2320h | No.185 | 9824 | 2660h | No.211 | 10656 | 29A0h | No.237 |
| 8192 | 2000h | No.160 | 9024 | 2340h | No.186 | 9856 | 2680h | No.212 | 10688 | 29C0h | No.238 |
| 8224 | 2020h | No.161 | 9056 | 2360h | No.187 | 9888 | 26A0h | No.213 | 10720 | 29E0h | No.239 |
| 8256 | 2040h | No.162 | 9088 | 2380h | No.188 | 9920 | 26C0h | No.214 | 10752 | 2A00h | No.240 |
| 8288 | 2060h | No.163 | 9120 | 23A0h | No.189 | 9952 | 26E0h | No.215 | 10784 | 2A20h | No.241 |
| 8320 | 2080h | No.164 | 9152 | 23C0h | No.190 | 9984 | 2700h | No.216 | 10816 | 2A40h | No.242 |
| 8352 | 20A0h | No.165 | 9184 | 23E0h | No.191 | 10016 | 2720h | No.217 | 10848 | 2A60h | No.243 |
| 8384 | 20C0h | No.166 | 9216 | 2400h | No.192 | 10048 | 2740h | No.218 | 10880 | 2A80h | No.244 |
| 8416 | 20E0h | No.167 | 9248 | 2420h | No.193 | 10080 | 2760h | No.219 | 10912 | 2AA0h | No.245 |
| 8448 | 2100h | No.168 | 9280 | 2440h | No.194 | 10112 | 2780h | No.220 | 10944 | 2AC0h | No.246 |
| 8480 | 2120h | No.169 | 9312 | 2460h | No.195 | 10144 | 27A0h | No.221 | 10976 | 2AE0h | No.247 |
| 8512 | 2140h | No.170 | 9344 | 2480h | No.196 | 10176 | 27C0h | No.222 | 11008 | 2B00h | No.248 |
| 8544 | 2160h | No.171 | 9376 | 24A0h | No.197 | 10208 | 27E0h | No.223 | 11040 | 2B20h | No.249 |
| 8576 | 2180h | No.172 | 9408 | 24C0h | No.198 | 10240 | 2800h | No.224 | 11072 | 2B40h | No.250 |
| 8608 | 21A0h | No.173 | 9440 | 24E0h | No.199 | 10272 | 2820h | No.225 | 11104 | 2B60h | No.251 |
| 8640 | 21C0h | No.174 | 9472 | 2500h | No.200 | 10304 | 2840h | No.226 | 11136 | 2B80h | No.252 |
| 8672 | 21E0h | No.175 | 9504 | 2520h | No.201 | 10336 | 2860h | No.227 | 11168 | 2BA0h | No.253 |
| 8704 | 2200h | No.176 | 9536 | 2540h | No.202 | 10368 | 2880h | No.228 | 11200 | 2BC0h | No.254 |
| 8736 | 2220h | No.177 | 9568 | 2560h | No.203 | 10400 | 28A0h | No.229 | 11232 | 2BE0h | No.255 |

4-2 Parameter ID

The setting item of operation data is set with the operation data R/W command.

The parameter ID for the setting item is arranged based on the base address of the operation data number.

(Base address → p.76)

For example, in the case of the setting item "Position," 1 is added to the base address.

| Parameter ID | Name | Setting range | Initial value | Update |
|------------------|---------------------------|--|---------------|--------|
| Base address +0 | Operation type | 1: Absolute positioning 2: Incremental positioning (based on command position) 3: Incremental positioning (based on feedback position) 7: Continuous operation (position control) 8: Wrap absolute positioning 9: Wrap proximity positioning 10: Wrap absolute positioning (FWD) 11: Wrap absolute positioning (RVS) 12: Wrap absolute push-motion 13: Wrap proximity push-motion 14: Wrap push-motion (FWD) 15: Wrap push-motion (RVS) 16: Continuous operation (Speed control) 17: Continuous operation (Push-motion) 18: Continuous operation (Torque control) 20: Absolute positioning push-motion 21: Incremental positioning push-motion (based on command position) 22: Incremental positioning push-motion (based on feedback position) | 2 | B |
| Base address +1 | Position | -2,147,483,648 to 2,147,483,647 steps | 0 | B |
| Base address +2 | Operating speed | -4,000,000 to 4,000,000 Hz | 1,000 | B |
| Base address +3 | Starting/changing rate | 1 to 1,000,000,000 (1=0.001 kHz/s, 1=0.001 s, or 1=0.001 ms/kHz) | 1,000,000 | B |
| Base address +4 | Stop | 1 to 1,000,000,000 (1=0.001 kHz/s, 1=0.001 s, or 1=0.001 ms/kHz) | 1,000,000 | B |
| Base address +5 | Operating current | 0 to 1,000 (1=0.1 %) | 1,000 | B |
| Base address +6 | Drive-complete delay time | 0 to 65,535 (1=0.001 s) | 0 | B |
| Base address +7 | Link | 0: No link 1: Manual sequential 2: Automatic sequential 3: Continuous sequential operation | 0 | B |
| Base address +8 | Next data number | -256: Stop -2: ↓↓ (+2) -1: ↓ (+1) 0 to 255: Operation data number | -1 | B |
| Base address +9 | Area offset | -2,147,483,648 to 2,147,483,647 steps | 0 | B |
| Base address +10 | Area width | -1: Disable 0 to 4,194,303: Set by 1 step | -1 | B |
| Base address +11 | Loop count | 0: None (-) 2 to 255: Number of loops (loop 2 { to loop 255 {) | 0 | B |
| Base address +12 | Loop offset | -4,194,304 to 4,194,303 steps | 0 | B |
| Base address +13 | Loop end point | 0: None (-) 1: Loop end (} L-End) | 0 | B |
| Base address +14 | (Low) I/O event number | -1: None (-) 0 to 31: Operation I/O event number (0 to 31) | -1 | B |

| Parameter ID | Name | Setting range | Initial value | Update |
|------------------|-------------------------|--|---------------|--------|
| Base address +15 | (High) I/O event number | -1: None (-) 0 to 31: Operation I/O event number (0 to 31) | -1 | B |

4-3 Setting example

As an example, this section explains how to set the following operation data to the operation data No.0 to No.2.

| Setting item | Operation data No.0 | Operation data No.1 | Operation data No.2 |
|-----------------------|----------------------|---|--|
| Operation type | Absolute positioning | Incremental positioning (based on command position) | Incremental positioning (based on feedback position) |
| Position [step] | 1,000 | 1,000 | 1,000 |
| Operating speed [Hz] | 1,000 | 1,000 | 1,000 |
| Operating current [%] | 50.0 | 70.0 | 100.0 |

■ Setting of operation data No.0

Seeing the table on p.76, we can find that the base address of the operation data No.0 is "3072 (0C00h)."
Based on this base address, the parameter ID for the setting item is calculated from the table on p.78.

| Setting item | Parameter ID | | | Setting value |
|-------------------|--------------------|-------------------|-------|---------------|
| | Calculation method | Dec | Hex | |
| Operation type | Base address +0 | $3072 + 0 = 3072$ | 0C00h | 1 |
| Position | Base address +1 | $3072 + 1 = 3073$ | 0C01h | 1,000 |
| Operating speed | Base address +2 | $3072 + 2 = 3074$ | 0C02h | 1,000 |
| Operating current | Base address +5 | $3072 + 5 = 3077$ | 0C05h | 500 |

■ Setting of operation data No.1

Seeing the table on p.76, we can find that the base address of the operation data No.1 is "3104 (0C20h)."
Based on this base address, the parameter ID for the setting item is calculated from the table on p.78.

| Setting item | Parameter ID | | | Setting value |
|-------------------|--------------------|-------------------|-------|---------------|
| | Calculation method | Dec | Hex | |
| Operation type | Base address +0 | $3104 + 0 = 3104$ | 0C20h | 2 |
| Position | Base address +1 | $3104 + 1 = 3105$ | 0C21h | 1,000 |
| Operating speed | Base address +2 | $3104 + 2 = 3106$ | 0C22h | 1,000 |
| Operating current | Base address +5 | $3104 + 5 = 3109$ | 0C25h | 700 |

■ Setting of operation data No.2

Seeing the table on p.76, we can find that the base address of the operation data No.2 is "3136 (0C40h)."
Based on this base address, the parameter ID for the setting item is calculated from the table on p.78.

| Setting item | Parameter ID | | | Setting value |
|-------------------|--------------------|-------------------|-------|---------------|
| | Calculation method | Dec | Hex | |
| Operation type | Base address +0 | $3136 + 0 = 3136$ | 0C40h | 3 |
| Position | Base address +1 | $3136 + 1 = 3137$ | 0C41h | 1,000 |
| Operating speed | Base address +2 | $3136 + 2 = 3138$ | 0C42h | 1,000 |
| Operating current | Base address +5 | $3136 + 5 = 3141$ | 0C45h | 1,000 |

5 Operation I/O event R/W commands

If a specified event (ON/OFF of I/O) is generated during operation of the motor, another operation can be started. This is called operation I/O event. This chapter explains the address to execute the operation I/O event.

5-1 Base address of operation I/O event

| Base address | | Operation I/O event number | Base address | | Operation I/O event number | Base address | | Operation I/O event number |
|--------------|-------|----------------------------|--------------|-------|----------------------------|--------------|-------|----------------------------|
| Dec | Hex | | Dec | Hex | | Dec | Hex | |
| 2560 | 0A00h | 0 | 2648 | 0A58h | 11 | 2736 | 0AB0h | 22 |
| 2568 | 0A08h | 1 | 2656 | 0A60h | 12 | 2744 | 0AB8h | 23 |
| 2576 | 0A10h | 2 | 2664 | 0A68h | 13 | 2752 | 0AC0h | 24 |
| 2584 | 0A18h | 3 | 2672 | 0A70h | 14 | 2760 | 0AC8h | 25 |
| 2592 | 0A20h | 4 | 2680 | 0A78h | 15 | 2768 | 0AD0h | 26 |
| 2600 | 0A28h | 5 | 2688 | 0A80h | 16 | 2776 | 0AD8h | 27 |
| 2608 | 0A30h | 6 | 2696 | 0A88h | 17 | 2784 | 0AE0h | 28 |
| 2616 | 0A38h | 7 | 2704 | 0A90h | 18 | 2792 | 0AE8h | 29 |
| 2624 | 0A40h | 8 | 2712 | 0A98h | 19 | 2800 | 0AF0h | 30 |
| 2632 | 0A48h | 9 | 2720 | 0AA0h | 20 | 2808 | 0AF8h | 31 |
| 2640 | 0A50h | 10 | 2728 | 0AA8h | 21 | | | |

5-2 Parameter ID for operation I/O event R/W command

The setting item of operation I/O event is set with the operation I/O event R/W command. The parameter ID for the setting item is arranged based on the base address of the operation I/O event. For example, in the case of the setting item "Dwell," 2 is added to the base address.

| Parameter ID | Name | Setting range | Initial value | Update |
|-----------------|-----------------------|--|----------------|--------|
| Base address +0 | Link | 0: No link 1: Manual sequential 2: Automatic sequential 3: Continuous sequential operation | 0 | B |
| Base address +1 | Next data number | -256: Stop -2: ↓↓ (+2) -1: ↓ (+1) 0 to 255: Operation data number | -256 | B |
| Base address +2 | Dwell | 0 to 65,535 (1=0.001 s) | 0 | B |
| Base address +3 | Event trigger I/O | Input signal list ⇨ p.96 Output signal list ⇨ p.97 | 0: No function | B |
| Base address +4 | Event trigger type | 0: Non 1: ON (calculated cumulative ms) 2: ON (ms) 3: OFF (calculated cumulative ms) 4: OFF (ms) 5: ON edge 6: OFF edge 7: ON (cumulative ms) 8: OFF (cumulative ms) | 0 | B |
| Base address +5 | Event trigger counter | 0 to 65,535 (1=1 ms or 1=once) | 0 | B |

6 Protect release commands

The key codes for reading/writing of data from/to the backup area and the key codes for release of function limitation by the HMI input are set.

Refer to the **AZ** Series [OPERATING MANUAL Function Edition](#) for details about parameters. When checking the **AZ** Series [OPERATING MANUAL Function Edition](#), use the parameter name instead of the parameter ID.

| Parameter ID | | Name | Setting range | Initial value |
|--------------|-------|------------------------|--------------------------|---------------|
| Dec | Hex | | | |
| 32 | 0020h | Backup DATA access key | Refer to the next table. | 0 |
| 33 | 0021h | Backup DATA write key | | |
| 34 | 0022h | HMI release key | | |

Key code table

| Process that requires protect release | Command name | Key code |
|---------------------------------------|------------------------|------------------------|
| Data writing to backup area | Backup DATA access key | 20519253 (01391955h) |
| | Backup DATA write key | 1977326743 (75DB9C97h) |
| Data reading from backup area | Backup DATA access key | 20519253 (01391955h) |
| Release of limitation by HMI input | HMI release key | 864617234 (33890312h) |

7 Extended operation data setting R/W command

Parameters for extended operation data setting can be set.

Refer to the **AZ Series OPERATING MANUAL Function Edition** for details about parameters. When checking the **AZ Series OPERATING MANUAL Function Edition**, use the parameter name instead of the parameter ID.

| Parameter ID | | Name | Setting range | Initial value | Update |
|--------------|-------|------------------------------------|--|---------------|--------|
| Dec | Hex | | | | |
| 320 | 0140h | Common acceleration rate or time | 1 to 1,000,000,000 (1=0.001 kHz/s, 1=0.001 s, or 1=0.001 ms/kHz) | 1,000,000 | A |
| 321 | 0141h | Common stopping deceleration | 1 to 1,000,000,000 (1=0.001 kHz/s, 1=0.001 s, or 1=0.001 ms/kHz) | 1,000,000 | A |
| 326 | 0146h | Rate selection | 0: The common rate is used 1: The rate of each operation data is used | 1 | A |
| 2048 | 0800h | Repeat start operation data number | -1: Disable 0 to 255: Operation data number | -1 | A |
| 2049 | 0801h | Repeat end operation data number | -1: Disable 0 to 255: Operation data number | -1 | A |
| 2050 | 0802h | Repeat time | -1: Disable 0 to 100,000,000 | -1 | A |



Rewrite the parameters of the extended operation data setting R/W command while operation is stopped.

8 Parameter R/W commands

These commands are used to write or read parameters.

Refer to the **AZ Series OPERATING MANUAL Function Edition** for details about parameters. When checking the **AZ Series OPERATING MANUAL Function Edition**, use the parameter name instead of the parameter ID.

8-1 Driver action simulation setting parameter

| Parameter ID | | Name | Setting range | Initial value | Update |
|--------------|-------|------------------------|--|---------------|--------|
| Dec | Hex | | | | |
| 511 | 01FFh | Driver simulation mode | 0: Use real motor 1: Virtual motor (when ABZO not connected = no ABZO information) 2: Virtual motor (when ABZO not connected = 1,800 rev wrap enable) 3: Virtual motor (when ABZO not connected = 900 rev wrap enable) | 0 | D |

8-2 Base setting parameter

| Parameter ID | | Name | Setting range | Initial value | Update |
|--------------|-------|--|--|---------------|--------|
| Dec | Hex | | | | |
| 294 | 0126h | Base current | 0 to 1,000 (1=0.1 %) | 1,000 | A |
| 296 | 0128h | Stop current | 0 to 1,000 (1=0.1 %) | 500 | A |
| 297 | 0129h | Command filter setting | 1: LPF (speed filter) 2: Moving average filter | 1 | B |
| 298 | 012Ah | Command filter time constant | 0 to 200 ms | 1 | B |
| 300 | 012Ch | Smooth drive function | 0: Disable 1: Enable | 1 | C |
| 301 | 012Dh | Current control mode | 0: Follow the CCM input 1: Alpha control mode (CST) 2: Servo emulation mode (SVE) | 0 | A |
| 302 | 012Eh | Servo emulation (SVE) ratio | 0 to 1,000 (1=0.1 %) | 1,000 | A |
| 303 | 012Fh | SVE position loop gain | 1 to 50 | 10 | A |
| 304 | 0130h | SVE speed loop gain | 10 to 200 | 180 | A |
| 305 | 0131h | SVE speed loop integral time constant | 100 to 2000 (1=0.1 ms) | 1,000 | A |
| 306 | 0132h | Automatic current cutback function | 0: Disable 1: Enable | 1 | A |
| 307 | 0133h | Automatic current cutback switching time | 0 to 1,000 ms | 100 | A |
| 308 | 0134h | Operating current ramp up rate | 0 to 100 ms/100 % | 0 | A |
| 309 | 0135h | Operating current ramp down rate | 0 to 100 ms/100 % | 0 | A |
| 311 | 0137h | Resonance suppression control frequency | 100 to 2,000 Hz | 1,000 | A |
| 312 | 0138h | Resonance suppression control gain | -500 to 500 | 0 | A |
| 313 | 0139h | Deviation acceleration suppressing gain | 0 to 500 | 45 | A |
| 506 | 01FAh | Main power mode * | -1: Automatic discrimination (discriminates the input power supply voltage automatically) 0: 24 VDC 1: 48 VDC | -1 | D |

* It is used to set the voltage mode of the main power supply. The voltage mode of the main power supply is discriminated in 50 ms after the main power supply is turned on. Set the "Main power mode" parameter to "0: 24 VDC" or "1: 48 VDC" when the main power supply starts up slowly or the voltage of the main power supply is unstable.

8-3 Coordinate parameters

| Parameter ID | | Name | Setting range | Initial value | Update |
|--------------|-------|-------------------------|---|----------------|--------|
| Dec | Hex | | | | |
| 451 | 01C3h | Software overtravel | -1: Disable 0: Immediate stop 1: Deceleration stop 2: Immediate stop with alarm 3: Deceleration stop with alarm | 3 | A |
| 452 | 01C4h | Positive software limit | -2,147,483,648 to 2,147,483,647 steps | 2,147,483,647 | A |
| 453 | 01C5h | Negative software limit | -2,147,483,648 to 2,147,483,647 steps | -2,147,483,648 | A |
| 454 | 01C6h | Preset position | -2,147,483,648 to 2,147,483,647 steps | 0 | A |

8-4 Operation parameters

| Parameter ID | | Name | Setting range | Initial value | Update |
|--------------|-------|---|-------------------------------|---------------|--------|
| Dec | Hex | | | | |
| 322 | 0142h | Starting speed | 0 to 4,000,000 Hz | 500 | B |
| 327 | 0147h | Acceleration/deceleration unit | 0: kHz/s 1: s 2: ms/kHz | 0 | C |
| 328 | 0148h | Permission of absolute positioning without setting absolute coordinates | 0: Disable 1: Enable | 0 | B |

8-5 Direct data operation parameters

| Parameter ID | | Name | Setting range | Initial value | Update |
|--------------|-------|---|--|---------------|--------|
| Dec | Hex | | | | |
| 272 | 0110h | Direct data operation zero speed command action | 0: Deceleration stop command 1: Speed zero command | 0 | B |
| 24852 | 6114h | Direct data operation trigger setting | -6: Operation type -5: Position -4: Speed -3: Starting/changing rate -2: Stopping deceleration -1: Operating current 0: Disable 1: Apply all data | 1 | A |

8-6 ABZO sensor setting parameters

| Parameter ID | | Name | Setting range | Initial value | Update |
|--------------|-------|---|---|---------------|--------|
| Dec | Hex | | | | |
| 2032 | 07F0h | Mechanism settings | 0: Prioritize ABZO setting 1: Manual setting | 0 | D |
| 2034 | 07F2h | Initial coordinate generation & wrap coordinate setting | 0: Prioritize ABZO setting 1: Manual setting | 0 | D |
| 2035 | 07F3h | Mechanism limit parameter setting | 0: Follow ABZO setting 1: Disable | 0 | D |
| 2036 | 07F4h | Mechanism protection parameter setting | 0: Follow ABZO setting 1: Disable | 0 | D |
| 2037 | 07F5h | JOG/HOME/ZHOME operation setting | 0: Prioritize ABZO setting 1: Manual setting | 0 | D |

8-7 Mechanism settings parameters

| Parameter ID | | Name | Setting range | Initial value | Update |
|--------------|-------|--------------------------------------|--|---------------|--------|
| Dec | Hex | | | | |
| 448 | 01C0h | Electronic gear A | 1 to 65,535 | 1 | C |
| 449 | 01C1h | Electronic gear B | 1 to 65,535 | 1 | C |
| 450 | 01C2h | Motor rotation direction | 0: Positive side=Counterclockwise 1: Positive side=Clockwise 2: Positive side=Counterclockwise (the driver parameter is applied) 3: Positive side=Clockwise (the driver parameter is applied) | 1 | C |
| 2017 | 07E1h | Mechanism lead pitch | 1 to 32,767 | 1 | C |
| 2033 | 07F1h | Gear ratio setting | 0: Gear ratio setting disable 1 to 32,767: Gear ratio (1=0.01) | 0 | C |
| 2553 | 09F9h | Mechanism lead decimal digit setting | 0: ×1 [mm] 1: ×0.1 [mm] 2: ×0.01 [mm] 3: ×0.001 [mm] | 0 | C |

8-8 Initial coordinate generation & wrap coordinate parameters

| Parameter ID | | Name | Setting range | Initial value | Update |
|--------------|-------|---|--------------------------------------|---------------|--------|
| Dec | Hex | | | | |
| 455 | 01C7h | Wrap setting | 0: Disable 1: Enable | 1 | C |
| 457 | 01C9h | Initial coordinate generation & wrap setting range | Refer to the next table. (1=0.1 rev) | 10 | C |
| 459 | 01CBh | Initial coordinate generation & wrap range offset ratio | 0 to 10,000 (1=0.01 %) | 5,000 | C |
| 460 | 01CCh | Initial coordinate generation & wrap range offset value | -536,870,912 to 536,870,911 steps | 0 | C |
| 461 | 01CDh | The number of the RND-ZERO output in wrap range | 1 to 536,870,911 divisions | 1 | C |

- Value that can be set in the "Initial coordinate generation & wrap setting range" parameter

Since the internal coordinate of the ABZO sensor is 1,800 rev (or 900 rev), select a value from the table, and set in the "Initial coordinate generation & wrap setting range" parameter. In the table, the values which are surrounded with thick box border cannot be set for the ABZO sensor of 900 revolutions.



The table shows the values when setting with the **MEXE02** software. When setting via Implicit communication, multiply the values in the table by 10.

| Wrap setting range [rev] | | | | | | |
|--------------------------|-----|------|------|------|-------|---------|
| 0.5 | 1.8 | 4.8 | 12.0 | 25.0 | 72.0 | 200.0 |
| 0.6 | 2.0 | 5.0 | 12.5 | 30.0 | 75.0 | 225.0 |
| 0.8 | 2.4 | 6.0 | 14.4 | 36.0 | 90.0 | 300.0 |
| 0.9 | 2.5 | 7.2 | 15.0 | 37.5 | 100.0 | 360.0 |
| 1.0 | 3.0 | 7.5 | 18.0 | 40.0 | 112.5 | 450.0 |
| 1.2 | 3.6 | 8.0 | 20.0 | 45.0 | 120.0 | 600.0 |
| 1.5 | 4.0 | 9.0 | 22.5 | 50.0 | 150.0 | 900.0 |
| 1.6 | 4.5 | 10.0 | 24.0 | 60.0 | 180.0 | 1,800.0 |

8-9 JOG/HOME/ZHOME operation information setting parameters

| Parameter ID | | Name | Setting range | Initial value | Update |
|--------------|-------|---|---|---------------|--------|
| Dec | Hex | | | | |
| 336 | 0150h | (JOG) Travel amount | 1 to 8,388,607 steps | 1 | B |
| 337 | 0151h | (JOG) Operating speed | 1 to 4,000,000 Hz | 1,000 | B |
| 338 | 0152h | (JOG) Acceleration/deceleration | 1 to 1,000,000,000 (1=0.001 kHz/s, 1=0.001 s, or 1=0.001 ms/kHz) | 1,000,000 | B |
| 339 | 0153h | (JOG) Starting speed | 0 to 4,000,000 Hz | 500 | B |
| 340 | 0154h | (JOG) Operating speed (high) | 1 to 4,000,000 Hz | 5000 | B |
| 344 | 0158h | (ZHOME) Operating speed | 1 to 4,000,000 Hz | 5000 | B |
| 345 | 0159h | (ZHOME) Acceleration/deceleration | 1 to 1,000,000,000 (1=0.001 kHz/s, 1=0.001 s, or 1=0.001 ms/kHz) | 1,000,000 | B |
| 346 | 015Ah | (ZHOME) Starting speed | 0 to 4,000,000 Hz | 500 | B |
| 350 | 015Eh | JOG/HOME/ZHOME command filter time constant | 1 to 200 ms | 1 | B |
| 351 | 015Fh | JOG/HOME/ZHOME operating current | 0 to 1,000 (1=0.1 %) | 1,000 | B |
| 352 | 0160h | (HOME) Home-seeking mode | 0: 2 sensors 1: 3 sensors * 2: One-way rotation 3: Push-motion | 2 | B |
| 353 | 0161h | (HOME) Starting direction | 0: Negative side 1: Positive side | 1 | B |
| 354 | 0162h | (HOME) Acceleration/deceleration | 1 to 1,000,000,000 (1=0.001 kHz/s, 1=0.001 s, or 1=0.001 ms/kHz) | 1,000,000 | B |
| 355 | 0163h | (HOME) Starting speed | 1 to 4,000,000 Hz | 500 | B |
| 356 | 0164h | (HOME) Operating speed | 1 to 4,000,000 Hz | 1,000 | B |
| 357 | 0165h | (HOME) Last speed | 1 to 10,000 Hz | 500 | B |
| 358 | 0166h | (HOME) SLIT detection | 0: Disable 1: Enable | 0 | B |
| 359 | 0167h | (HOME) TIM/ZSG signal detection | 0: Disable 1: TIM output 2: ZSG output | 0 | B |
| 360 | 0168h | (HOME) Position offset | -2,147,483,647 to 2,147,483,647 steps | 0 | B |

| Parameter ID | | Name | Setting range | Initial value | Update |
|--------------|-------|--|----------------------|---------------|--------|
| Dec | Hex | | | | |
| 361 | 0169h | (HOME) Backward steps in 2 sensor home-seeking | 0 to 8,388,607 steps | 500 | B |
| 362 | 016Ah | (HOME) Operating amount in uni-directional home-seeking | 0 to 8,388,607 steps | 500 | B |
| 363 | 016Bh | (HOME) Operating current for push-home-seeking | 0 to 1,000 (1=0.1 %) | 1,000 | B |
| 364 | 016Ch | (HOME) Backward steps after first entry in push-home-seeking | 0 to 8,388,607 steps | 0 | B |
| 365 | 016Dh | (HOME) Pushing time in push-home-seeking | 1 to 65,535 ms | 200 | B |
| 366 | 016Eh | (HOME) Backward steps in push-home-seeking | 0 to 8,388,607 steps | 500 | B |

* Two input signals are provided for the mini Driver. Return-to-home operation of the 3-sensor mode requires three inputs: HOMES input, FW-LS input, and RV-LS input. Therefore, return-to-home operation of the 3-sensor mode is not recommended for the mini Driver.

8-10 Alarm setting parameters

| Parameter ID | | Name | Setting range | Initial value | Update |
|--------------|-------|------------------------------------|--------------------------|---------------|--------|
| Dec | Hex | | | | |
| 384 | 0180h | Overload alarm | 1 to 300 (1=0.1 s) | 50 | A |
| 385 | 0181h | Excessive position deviation alarm | 1 to 30,000 (1=0.01 rev) | 300 | A |
| 24968 | 6188h | Network bus error alarm | 0: Disable 1: Enable | 1 | A |

8-11 Information setting parameters

| Parameter ID | | Name | Setting range | Initial value | Update |
|--------------|-------|--|---|---------------|--------|
| Dec | Hex | | | | |
| 416 | 01A0h | Driver temperature information (INFO-DRVTMP) | 40 to 85 °C | 85 | A |
| 417 | 01A1h | Overload time information (INFO-OLTIME) | 1 to 300 (1=0.1 s) | 50 | A |
| 418 | 01A2h | Speed information (INFO-SPD) | 0: Disable 1 to 12,000 r/min | 0 | A |
| 421 | 01A5h | Position deviation information (INFO-POSERR) | 1 to 30,000 (1=0.01 rev) | 300 | A |
| 424 | 01A8h | Motor temperature information (INFO-MTRTMP) | 40 to 120 °C | 85 | A |
| 427 | 01ABh | Overvoltage information (INFO-OVOLT) | 140 to 630 (1=0.1 V) | 630 | A |
| 428 | 01ACh | Undervoltage information (INFO-UVOLT) | 140 to 630 (1=0.1 V) | 140 | A |
| 431 | 01AFh | Trip meter information (INFO-TRIP) | 0: Disable 1 to 2,147,483,647 (1=0.1 kRev) | 0 | A |
| 432 | 01B0h | Odometer information (INFO-ODO) | 0: Disable 1 to 2,147,483,647 (1=0.1 kRev) | 0 | A |
| 433 | 01B1h | Cumulative load 0 information (INFO-CULD0) | 0 to 2,147,483,647 | 0 | A |
| 434 | 01B2h | Cumulative load 1 information (INFO-CULD1) | 0 to 2,147,483,647 | 0 | A |

| Parameter ID | | Name | Setting range | Initial value | Update |
|--------------|-------|---|--|-------------------|--------|
| Dec | Hex | | | | |
| 435 | 01B3h | Cumulative load value auto clear | 0: Disable 1: Enable | 1 | A |
| 436 | 01B4h | Cumulative load value count divisor | 1 to 32,767 | 1 | A |
| 444 | 01BCh | INFO-USRIO output selection | Output signals list ⇨ p.97 | 128: CONST-OFF | A |
| 445 | 01BDh | INFO-USRIO output inversion | 0: Not invert 1: Invert | 0 | A |
| 446 | 01BEh | Information LED condition | 0: Disable (LED does not blink) 1: Enable (LED blinks) | 1 | A |
| 447 | 01BFh | Information auto clear | 0: Disabled (not turned OFF automatically) 1: Enabled (turned OFF automatically) | 1 | A |
| 1952 | 07A0h | INFO action (Assigned I/O status information (INFO-USRIO)) | 0: No info reflect (Only the bit output is ON.) 1: Info reflect (The bit output and the INFO output are ON and the LED blinks.) | 1 | A |
| 1953 | 07A1h | INFO action (Position deviation information (INFO-POSERR)) | | | |
| 1954 | 07A2h | INFO action (Driver temperature information (INFO-DRVTMP)) | | | |
| 1955 | 07A3h | INFO action (Motor temperature information (INFO-MTRTMP)) | | | |
| 1956 | 07A4h | INFO action (Overvoltage information (INFO-OVOLT)) | | | |
| 1957 | 07A5h | INFO action (Undervoltage information (INFO-UVOLT)) | | | |
| 1958 | 07A6h | INFO action (Overload time information (INFO-OLTIME)) | | | |
| 1960 | 07A8h | INFO action (Speed information (INFO-SPD)) | | | |
| 1961 | 07A9h | INFO action (Start operation error information (INFO-START)) | | | |
| 1962 | 07AAh | INFO action (Start ZHOME error information (INFO-ZHOME)) | | | |
| 1963 | 07ABh | INFO action (PRESET request information (INFO-PR-REQ)) | | | |
| 1965 | 07ADh | INFO action (Electronic gear setting error information (INFO-EGR-E)) | | | |
| 1966 | 07AEh | INFO action (Wrap setting error information (INFO-RND-E)) | | | |
| 1968 | 07B0h | INFO action (Forward operation prohibition information (INFO-FW-OT)) | | | |
| 1969 | 07B1h | INFO action (Reverse operation prohibition information (INFO-RV-OT)) | | | |
| 1970 | 07B2h | INFO action (Cumulative load 0 information (INFO-CULD0)) | | | |
| 1971 | 07B3h | INFO action (Cumulative load 1 information (INFO-CULD1)) | | | |
| 1972 | 07B4h | INFO action (Tripmeter information (INFO-TRIP)) | | | |
| 1973 | 07B5h | INFO action (Odometer information (INFO-ODO)) | | | |
| 1980 | 07BCh | INFO action (Start operation restricted mode information (INFO-DSLMTD)) | | | |

| Parameter ID | | Name | Setting range | Initial value | Update |
|--------------|-------|--|--|---------------|--------|
| Dec | Hex | | | | |
| 1981 | 07BDh | INFO action (I/O test mode information (INFO-IOTEST)) | 0: No info reflect (Only the bit output is ON.) 1: Info reflect (The bit output and the INFO output are ON and the LED blinks.) | 1 | A |
| 1982 | 07BEh | INFO action (Configuration request information (INFO-CFG)) | | | |
| 1983 | 07BFh | INFO action (Reboot request information (INFO-RBT)) | | | |

8-12 I/O parameters

| Parameter ID | | Name | Setting range | Initial value | Update |
|--------------|-------|---|--|---------------|--------|
| Dec | Hex | | | | |
| 1792 | 0700h | STOP/STOP-COFF input action | 0: Both are immediate 1: (STOP) Dec. & (STOP-COFF) Imm. 2: (STOP) Imm. & (STOP-COFF) Dec. 3: Both are deceleration | 3 | A |
| 1793 | 0701h | FW-LS, RV-LS input action | -1: For homing sensor 0: Immediate stop 1: Deceleration stop 2: Immediate stop with alarm 3: Deceleration stop with alarm | 2 | A |
| 1794 | 0702h | FW-BLK/RV-BLK input action | 0: Immediate stop 1: Deceleration stop | 1 | A |
| 1795 | 0703h | IN-POS positioning completion signal range | 0 to 180 (1=0.1°) | 18 | A |
| 1796 | 0704h | IN-POS positioning completion signal offset | -18 to 18 (1=0.1°) | 0 | A |
| 1797 | 0705h | D-SEL drive start function | 0: Without START-Func. (only select data) (Only operation data number selection) 1: With START-Func (Operation data number selection + START function) | 1 | A |
| 1798 | 0706h | TEACH operation type setting | -1: Not set 1: Absolute positioning 8: Wrap absolute positioning | 1 | A |
| 1799 | 0707h | ZSG signal width | 1 to 1,800 (1=0.1°) | 18 | A |
| 1800 | 0708h | RND-ZERO signal width | 1 to 10,000 steps | 10 | A |
| 1801 | 0709h | RND-ZERO signal source | 0: Based on feedback position 1: Based on command position | 0 | A |
| 1802 | 070Ah | MOVE minimum ON time | 0 to 255 ms | 0 | A |
| 1803 | 070Bh | PAUSE standby condition selection | 0: Standstill mode (current cutback) 1: Operation mode (operating current is retained) | 0 | A |
| 1805 | 070Dh | CRNT-LMT operating current limit value | 0 to 1,000 (1=0.1 %) | 500 | A |
| 1806 | 070Eh | SPD-LMT speed limit type selection | 0: Ratio 1: Value | 0 | A |
| 1807 | 070Fh | SPD-LMT speed limit ratio | 1 to 100 % | 50 | A |
| 1808 | 0710h | SPD-LMT speed limit value | 1 to 4,000,000 Hz | 1,000 | A |
| 1809 | 0711h | JOG-C time from JOG-P to JOG | 1 to 5,000 (1=0.001 s) | 500 | B |
| 1810 | 0712h | JOG-C time from JOG to JOG-H | 1 to 5,000 (1=0.001 s) | 1,000 | B |

| Parameter ID | | Name | Setting range | Initial value | Update |
|--------------|-------|---|--|---------------|--------|
| Dec | Hex | | | | |
| 1816 | 0718h | VA mode selection | 0: Feedback speed attainment (speed at feedback position) 1: Speed at command position (only internal profile) 2: Speed at feedback position & command position (only internal profile) | 0 | B |
| 1817 | 0719h | VA detection speed range | 1 to 200 r/min | 30 | B |
| 1818 | 071Ah | MAREA output source | 0: Feedback position (ON after operation) 1: Command position (ON after operation) 2: Feedback position (MAREA output OFF at completion) 3: Command position (MAREA output OFF at completion) | 0 | A |
| 1856 | 0740h | AREA0 positive direction position/offset | -2,147,483,648 to 2,147,483,647 steps | 0 | A |
| 1857 | 0741h | AREA0 negative direction position/detection range | | | |
| 1858 | 0742h | AREA1 positive direction position/offset | | | |
| 1859 | 0743h | AREA1 negative direction position/detection range | | | |
| 1860 | 0744h | AREA2 positive direction position/offset | | | |
| 1861 | 0745h | AREA2 negative direction position/detection range | | | |
| 1862 | 0746h | AREA3 positive direction position/offset | | | |
| 1863 | 0747h | AREA3 negative direction position/detection range | | | |
| 1864 | 0748h | AREA4 positive direction position/offset | | | |
| 1865 | 0749h | AREA4 negative direction position/detection range | | | |
| 1866 | 074Ah | AREA5 positive direction position/offset | | | |
| 1867 | 074Bh | AREA5 negative direction position/detection range | | | |
| 1868 | 074Ch | AREA6 positive direction position/offset | | | |
| 1869 | 074Dh | AREA6 negative direction position/detection range | | | |
| 1870 | 074Eh | AREA7 positive direction position/offset | 0: Range setting with absolute value 1: Offset/width setting from the target position | 0 | A |
| 1871 | 074Fh | AREA7 negative direction position/detection range | | | |
| 1872 | 0750h | AREA0 range setting mode | | | |
| 1873 | 0751h | AREA1 range setting mode | | | |
| 1874 | 0752h | AREA2 range setting mode | | | |
| 1875 | 0753h | AREA3 range setting mode | | | |
| 1876 | 0754h | AREA4 range setting mode | | | |
| 1877 | 0755h | AREA5 range setting mode | | | |
| 1878 | 0756h | AREA6 range setting mode | | | |
| 1879 | 0757h | AREA7 range setting mode | | | |

| Parameter ID | | Name | Setting range | Initial value | Update |
|--------------|-------|---|---|---------------|--------|
| Dec | Hex | | | | |
| 1880 | 0758h | AREA0 positioning standard | 0: Based on feedback position 1: Based on command position | 0 | A |
| 1881 | 0759h | AREA1 positioning standard | | | |
| 1882 | 075Ah | AREA2 positioning standard | | | |
| 1883 | 075Bh | AREA3 positioning standard | | | |
| 1884 | 075Ch | AREA4 positioning standard | | | |
| 1885 | 075Dh | AREA5 positioning standard | | | |
| 1886 | 075Eh | AREA6 positioning standard | | | |
| 1887 | 075Fh | AREA7 positioning standard | 0 to 255: Operation data number | 0 | A |
| 1888 | 0760h | D-SEL0 operation number selection | | | |
| 1889 | 0761h | D-SEL1 operation number selection | | | |
| 1890 | 0762h | D-SEL2 operation number selection | | | |
| 1891 | 0763h | D-SEL3 operation number selection | | | |
| 1892 | 0764h | D-SEL4 operation number selection | | | |
| 1893 | 0765h | D-SEL5 operation number selection | | | |
| 1894 | 0766h | D-SEL6 operation number selection | | | |
| 1895 | 0767h | D-SEL7 operation number selection | 0 to 255: Operation data number | 0 | A |
| 1896 | 0768h | D-END0 operation number selection | | | |
| 1897 | 0769h | D-END1 operation number selection | | | |
| 1898 | 076Ah | D-END2 operation number selection | | | |
| 1899 | 076Bh | D-END3 operation number selection | | | |
| 1900 | 076Ch | D-END4 operation number selection | | | |
| 1901 | 076Dh | D-END5 operation number selection | | | |
| 1902 | 076Eh | D-END6 operation number selection | | | |
| 1903 | 076Fh | D-END7 operation number selection | 0: Stop current 1: Operating current | 0 | A |
| 2554 | 09FAh | Current setting during motor standstill at T-MODE | | | |

8-13 Direct I/O setting parameters

| Parameter ID | | Name | Setting range | Initial value | Update |
|--------------|-------|-------------------------------|---|---------------|--------|
| Dec | Hex | | | | |
| 2112 | 0840h | DIN0 input function | Input signals list ⇨ p.96 | 5: STOP | C |
| 2113 | 0841h | DIN1 input function | | 1: FREE | |
| 2128 | 0850h | DIN0 inverting mode | 0: Not invert | 0 | C |
| 2129 | 0851h | DIN1 inverting mode | 1: Invert | | |
| 2176 | 0880h | DIN0 composite input function | Input signals list ⇨ p.96 | 0: | C |
| 2177 | 0881h | DIN1 composite input function | | No function | |
| 2240 | 08C0h | DIN0 ON signal dead-time | 0 to 250 ms | 0 | C |
| 2241 | 08C1h | DIN1 ON signal dead-time | | | |
| 2256 | 08D0h | DIN0 1 shot signal | 0: The 1 shot signal function is disabled | 0 | C |
| 2257 | 08D1h | DIN1 1 shot signal | 1: The 1 shot signal function is enabled | | |

8-14 Remote I/O setting parameters

| Parameter ID | | Name | Setting range | Initial value | Update |
|--------------|-------|-------------------------|----------------------------|----------------|--------|
| Dec | Hex | | | | |
| 2304 | 0900h | R-IN0 input function | Input signals list ⇨ p.96 | 0: No function | C |
| 2305 | 0901h | R-IN1 input function | | | |
| 2306 | 0902h | R-IN2 input function | | | |
| 2307 | 0903h | R-IN3 input function | | | |
| 2308 | 0904h | R-IN4 input function | | | |
| 2309 | 0905h | R-IN5 input function | | | |
| 2310 | 0906h | R-IN6 input function | | | |
| 2311 | 0907h | R-IN7 input function | | | |
| 2312 | 0908h | R-IN8 input function | | | |
| 2313 | 0909h | R-IN9 input function | | | |
| 2314 | 090Ah | R-IN10 input function | | | |
| 2315 | 090Bh | R-IN11 input function | | | |
| 2316 | 090Ch | R-IN12 input function | | | |
| 2317 | 090Dh | R-IN13 input function | | | |
| 2318 | 090Eh | R-IN14 input function | | | |
| 2319 | 090Fh | R-IN15 input function | | | |
| 2320 | 0910h | R-OUT0 output function | Output signals list ⇨ p.97 | 64: M0_R | C |
| 2321 | 0911h | R-OUT1 output function | | 65: M1_R | |
| 2322 | 0912h | R-OUT2 output function | | 66: M2_R | |
| 2323 | 0913h | R-OUT3 output function | | 32: START_R | |
| 2324 | 0914h | R-OUT4 output function | | 144: HOME-END | |
| 2325 | 0915h | R-OUT5 output function | | 132: READY | |
| 2326 | 0916h | R-OUT6 output function | | 135: INFO | |
| 2327 | 0917h | R-OUT7 output function | | 129: ALM-A | |
| 2328 | 0918h | R-OUT8 output function | | 136: SYS-BSY | |
| 2329 | 0919h | R-OUT9 output function | | 160: AREA0 | |
| 2330 | 091Ah | R-OUT10 output function | | 161: AREA1 | |
| 2331 | 091Bh | R-OUT11 output function | | 162: AREA2 | |
| 2332 | 091Ch | R-OUT12 output function | | 157: TIM | |

| Parameter ID | | Name | Setting range | Initial value | Update |
|--------------|-------|-------------------------|----------------------------|---------------|--------|
| Dec | Hex | | | | |
| 2333 | 091Dh | R-OUT13 output function | Output signals list ⇨ p.97 | 134: MOVE | C |
| 2334 | 091Eh | R-OUT14 output function | | 138: IN-POS | |
| 2335 | 091Fh | R-OUT15 output function | | 140: TLC | |
| 2352 | 0930h | R-OUT0 OFF delay time | 0 to 250 ms | 0 | C |
| 2353 | 0931h | R-OUT1 OFF delay time | | | |
| 2354 | 0932h | R-OUT2 OFF delay time | | | |
| 2355 | 0933h | R-OUT3 OFF delay time | | | |
| 2356 | 0934h | R-OUT4 OFF delay time | | | |
| 2357 | 0935h | R-OUT5 OFF delay time | | | |
| 2358 | 0936h | R-OUT6 OFF delay time | | | |
| 2359 | 0937h | R-OUT7 OFF delay time | | | |
| 2360 | 0938h | R-OUT8 OFF delay time | | | |
| 2361 | 0939h | R-OUT9 OFF delay time | | | |
| 2362 | 093Ah | R-OUT10 OFF delay time | | | |
| 2363 | 093Bh | R-OUT11 OFF delay time | | | |
| 2364 | 093Ch | R-OUT12 OFF delay time | | | |
| 2365 | 093Dh | R-OUT13 OFF delay time | | | |
| 2366 | 093Eh | R-OUT14 OFF delay time | | | |
| 2367 | 093Fh | R-OUT15 OFF delay time | | | |

8-15 Virtual input parameters

| Parameter ID | | Name | Setting range | Initial value | Update |
|--------------|-------|---|-------------------------------|----------------|--------|
| Dec | Hex | | | | |
| 2368 | 0940h | Virtual input (VIR-IN0) function | Input signals list ⇨ p.96 | 0: No function | C |
| 2369 | 0941h | Virtual input (VIR-IN1) function | | | |
| 2370 | 0942h | Virtual input (VIR-IN2) function | | | |
| 2371 | 0943h | Virtual input (VIR-IN3) function | | | |
| 2372 | 0944h | Virtual input (VIR-IN0) source selection | Output signals list ⇨ p.97 | 128: CONST-OFF | C |
| 2373 | 0945h | Virtual input (VIR-IN1) source selection | | | |
| 2374 | 0946h | Virtual input (VIR-IN2) source selection | | | |
| 2375 | 0947h | Virtual input (VIR-IN3) source selection | 0: Not invert 1: Invert | 0 | C |
| 2376 | 0948h | Virtual input (VIR-IN0) inverting mode | | | |
| 2377 | 0949h | Virtual input (VIR-IN1) inverting mode | | | |
| 2378 | 094Ah | Virtual input (VIR-IN2) inverting mode | 0 to 250 ms | 0 | C |
| 2379 | 094Bh | Virtual input (VIR-IN3) inverting mode | | | |
| 2380 | 094Ch | Virtual input (VIR-IN0) ON signal dead time | | | |
| 2381 | 094Dh | Virtual input (VIR-IN1) ON signal dead time | 0: Disable 1: Enable | 0 | C |
| 2382 | 094Eh | Virtual input (VIR-IN2) ON signal dead time | | | |
| 2383 | 094Fh | Virtual input (VIR-IN3) ON signal dead time | | | |
| 2384 | 0950h | Virtual input (VIR-IN0) 1 shot signal mode | 0: Disable 1: Enable | 0 | C |
| 2385 | 0951h | Virtual input (VIR-IN1) 1 shot signal mode | | | |
| 2386 | 0952h | Virtual input (VIR-IN2) 1 shot signal mode | | | |
| 2387 | 0953h | Virtual input (VIR-IN3) 1 shot signal mode | | | |

8-16 User output setting parameters

| Parameter ID | | Name | Setting range | Initial value | Update |
|--------------|-------|--|-------------------------------|----------------|--------|
| Dec | Hex | | | | |
| 2400 | 0960h | User output (USR-OUT0) source A function | Output signals list ⇒ p.97 | 128: CONST-OFF | C |
| 2401 | 0961h | User output (USR-OUT1) source A function | | | |
| 2402 | 0962h | User output (USR-OUT0) source A inverting mode | 0: Not invert 1: Invert | 0 | C |
| 2403 | 0963h | User output (USR-OUT1) source A inverting mode | | | |
| 2404 | 0964h | User output (USR-OUT0) source B function | Output signals list ⇒ p.97 | 128: CONST-OFF | C |
| 2405 | 0965h | User output (USR-OUT1) source B function | | | |
| 2406 | 0966h | User output (USR-OUT0) source B inverting mode | 0: Not invert 1: Invert | 0 | C |
| 2407 | 0967h | User output (USR-OUT1) source B inverting mode | | | |
| 2408 | 0968h | User output (USR-OUT0) logical operation | 0: AND 1: OR | 1 | C |
| 2409 | 0969h | User output (USR-OUT1) logical operation | | | |

8-17 Driver mode setting parameters

| Parameter ID | | Name | Setting range | Initial value | Update |
|--------------|-------|---------------|-------------------------|---------------|--------|
| Dec | Hex | | | | |
| 498 | 01F2h | USB-ID enable | 0: Disable 1: Enable | 1 | D |
| 499 | 01F3h | USB-ID | 0 to 999,999,999 | 0 | D |
| 2555 | 09FBh | USB-PID | 0 to 31 | 0 | D |

8-18 EtherNet/IP communication setting parameters

● Assignable monitor setting parameters

| Parameter ID | | Name | Setting range | Initial value | Update |
|--------------|-------|------------------------------|---|------------------------------|--------|
| Dec | Hex | | | | |
| 25600 | 6400h | Assignable monitor address 0 | Set from items of "4 Parameter ID lists." | 124: Driver temperature | A |
| 25601 | 6401h | Assignable monitor address 1 | | 125: Motor temperature | |
| 25602 | 6402h | Assignable monitor address 2 | | 109: Cumulative load monitor | |
| 25603 | 6403h | Assignable monitor address 3 | | 127: Tripmeter | |

- **IP address setting parameters**

These are set using the **MEXE02** software. They cannot be read or written via Implicit communication.

| Parameter ID | | Name | Description | Setting range | Initial value | Update |
|--------------|-----|-----------------------|------------------------------------|--------------------------------|---------------|--------|
| Dec | Hex | | | | | |
| – | – | Configuration Control | Sets how to obtain the IP address. | 0: Parameter 2: DHCP server | 2 | D |
| – | – | IP Address 1 | Sets the IP address. | 0 to 255 | 192 | D |
| – | – | IP Address 2 | | | 168 | |
| – | – | IP Address 3 | | | 1 | |
| – | – | IP Address 4 | | | 1 | |
| – | – | Network Mask 1 | Sets the subnet mask. | 0 to 255 | 255 | D |
| – | – | Network Mask 2 | | | 255 | |
| – | – | Network Mask 3 | | | 255 | |
| – | – | Network Mask 4 | | | 0 | |
| – | – | Gateway Address 1 | Sets the default gateway. | 0 to 255 | 0 | D |
| – | – | Gateway Address 2 | | | 0 | |
| – | – | Gateway Address 3 | | | 0 | |
| – | – | Gateway Address 4 | | | 0 | |

9 I/O signals assignment list

To assign signals via industrial network, use the "assignment numbers" in the table instead of the signal names.

9-1 Input signals

| Assignment number | Signal name | Assignment number | Signal name | Assignment number | Signal name |
|-------------------|-------------|-------------------|-------------|-------------------|-------------|
| 0 | Not used | 33 | SSTART | 61 | RV-PSH |
| 1 | FREE | 35 | NEXT | 64 | M0 |
| 2 | C-ON | 36 | HOME | 65 | M1 |
| 3 | CLR | 37 | ZHOME | 66 | M2 |
| 4 | STOP-COFF | 40 | D-SEL0 | 67 | M3 |
| 5 | STOP | 41 | D-SEL1 | 68 | M4 |
| 6 | PAUSE | 42 | D-SEL2 | 69 | M5 |
| 7 | BREAK-ATSQ | 43 | D-SEL3 | 70 | M6 |
| 8 | ALM-RST | 44 | D-SEL4 | 71 | M7 |
| 9 | P-PRESET | 45 | D-SEL5 | 75 | TEACH |
| 10 | EL-PRST | 46 | D-SEL6 | 80 | R0 |
| 13 | LAT-CLR | 47 | D-SEL7 | 81 | R1 |
| 14 | INFO-CLR | 48 | FW-JOG | 82 | R2 |
| 16 | HMI | 49 | RV-JOG | 83 | R3 |
| 18 | CCM | 50 | FW-JOG-H | 84 | R4 |
| 21 | T-MODE | 51 | RV-JOG-H | 85 | R5 |
| 22 | CRNT-LMT | 52 | FW-JOG-P | 86 | R6 |
| 23 | SPD-LMT | 53 | RV-JOG-P | 87 | R7 |
| 26 | FW-BLK | 54 | FW-JOG-C | 88 | R8 |
| 27 | RV-BLK | 55 | RV-JOG-C | 89 | R9 |
| 28 | FW-LS | 56 | FW-POS | 90 | R10 |
| 29 | RV-LS | 57 | RV-POS | 91 | R11 |
| 30 | HOMES | 58 | FW-SPD | 92 | R12 |
| 31 | SLIT | 59 | RV-SPD | 93 | R13 |
| 32 | START | 60 | FW-PSH | 94 | R14 |
| | | | | 95 | R15 |

9-2 Output signals

| Assignment number | Signal name | Assignment number | Signal name | Assignment number | Signal name |
|-------------------|--------------|-------------------|-------------|-------------------|-------------|
| 0 | Not used | 56 | FW-POS_R | 145 | ABSPEN |
| 1 | FREE_R | 57 | RV-POS_R | 146 | ELPRST-MON |
| 2 | C-ON_R | 58 | FW-SPD_R | 149 | PRST-DIS |
| 3 | CLR_R | 59 | RV-SPD_R | 150 | PRST-STLD |
| 4 | STOP-COFF_R | 60 | FW-PSH_R | 151 | ORGN-STLD |
| 5 | STOP_R | 61 | RV-PSH_R | 152 | RND-OVF |
| 6 | PAUSE_R | 64 | M0_R | 153 | FW-SLS |
| 7 | BREAK-ATSQ_R | 65 | M1_R | 154 | RV-SLS |
| 8 | ALM-RST_R | 66 | M2_R | 155 | ZSG |
| 9 | P-PRESET_R | 67 | M3_R | 156 | RND-ZERO |
| 10 | EL-PRST_R | 68 | M4_R | 157 | TIM |
| 13 | LAT-CLR_R | 69 | M5_R | 159 | MAREA |
| 14 | INFO-CLR_R | 70 | M6_R | 160 | AREA0 |
| 16 | HMI_R | 71 | M7_R | 161 | AREA1 |
| 18 | CCM_R | 75 | TEACH_R | 162 | AREA2 |
| 21 | T-MODE_R | 80 | R0_R | 163 | AREA3 |
| 22 | CRNT-LMT_R | 81 | R1_R | 164 | AREA4 |
| 23 | SPD-LMT_R | 82 | R2_R | 165 | AREA5 |
| 26 | FW-BLK_R | 83 | R3_R | 166 | AREA6 |
| 27 | RV-BLK_R | 84 | R4_R | 167 | AREA7 |
| 28 | FW-LS_R | 85 | R5_R | 168 | MPS |
| 29 | RV-LS_R | 86 | R6_R | 169 | MBC |
| 30 | HOMES_R | 87 | R7_R | 180 | USR-OUT0 |
| 31 | SLIT_R | 88 | R8_R | 181 | USR-OUT1 |
| 32 | START_R | 89 | R9_R | 192 | CRNT-LMTD |
| 33 | SSTART_R | 90 | R10_R | 193 | SPD-LMTD |
| 35 | NEXT_R | 91 | R11_R | 196 | OPE-BSY |
| 36 | HOME_R | 92 | R12_R | 197 | PAUSE-BSY |
| 37 | ZHOME_R | 93 | R13_R | 198 | SEQ-BSY |
| 40 | D-SEL0_R | 94 | R14_R | 199 | DELAY-BSY |
| 41 | D-SEL1_R | 95 | R15_R | 200 | JUMPO-LAT |
| 42 | D-SEL2_R | 128 | CONST-OFF | 201 | JUMP1-LAT |
| 43 | D-SEL3_R | 129 | ALM-A | 202 | NEXT-LAT |
| 44 | D-SEL4_R | 130 | ALM-B | 204 | DCMD-RDY |
| 45 | D-SEL5_R | 131 | SYS-RDY | 205 | DCMD-FULL |
| 46 | D-SEL6_R | 132 | READY | 207 | M-CHG |
| 47 | D-SEL7_R | 134 | MOVE | 208 | M-ACT0 |
| 48 | FW-JOG_R | 135 | INFO | 209 | M-ACT1 |
| 49 | RV-JOG_R | 136 | SYS-BSY | 210 | M-ACT2 |
| 50 | FW-JOG-H_R | 138 | IN-POS | 211 | M-ACT3 |
| 51 | RV-JOG-H_R | 140 | TLC | 212 | M-ACT4 |
| 52 | FW-JOG-P_R | 141 | VA | 213 | M-ACT5 |
| 53 | RV-JOG-P_R | 142 | CRNT | 214 | M-ACT6 |
| 54 | FW-JOG-C_R | 143 | AUTO-CD | 215 | M-ACT7 |
| 55 | RV-JOG-C_R | 144 | HOME-END | 216 | D-END0 |

I/O signals assignment list

| Assignment number | Signal name | Assignment number | Signal name |
|-------------------|-------------|-------------------|-------------|
| 217 | D-END1 | 233 | INFO-START |
| 218 | D-END2 | 234 | INFO-ZHOME |
| 219 | D-END3 | 235 | INFO-PR-REQ |
| 220 | D-END4 | 237 | INFO-EGR-E |
| 221 | D-END5 | 238 | INFO-RND-E |
| 222 | D-END6 | 240 | INFO-FW-OT |
| 223 | D-END7 | 241 | INFO-RV-OT |
| 224 | INFO-USRIO | 242 | INFO-CULD0 |
| 225 | INFO-POSERR | 243 | INFO-CULD1 |
| 226 | INFO-DRVTMP | 244 | INFO-TRIP |
| 227 | INFO-MTRTMP | 245 | INFO-ODO |
| 228 | INFO-OVOLT | 252 | INFO-DSLMTD |
| 229 | INFO-UVOLT | 253 | INFO-IOTEST |
| 230 | INFO-OLTIME | 254 | INFO-CFG |
| 232 | INFO-SPD | 255 | INFO-RBT |

5 Troubleshooting

This part explains alarm and information functions.

◆ Table of contents

| | | |
|----------|---|------------|
| 1 | Detection of communication errors..... | 100 |
| 1-1 | Communication timeout | 100 |
| 1-2 | IP address conflict..... | 100 |
| 2 | Alarms..... | 101 |
| 2-1 | Alarm reset..... | 101 |
| 2-2 | Alarm history..... | 101 |
| 2-3 | Generation condition of alarms | 101 |
| 2-4 | Alarm list..... | 102 |
| 2-5 | Timing chart | 107 |
| 3 | Information..... | 109 |
| 3-1 | Information history..... | 112 |
| 3-2 | Information list..... | 112 |
| 4 | Troubleshooting and remedial actions | 115 |



1 Detection of communication errors

This chapter explains a function to detect that an error occurred in EtherNet/IP.

1-1 Communication timeout

If Implicit communication is interrupted due to disconnection of the EtherNet/IP cable or other reasons, the communication timeout is detected.

When the communication timeout is detected, the NS LED on the driver blinks in red.

When connection with the scanner is established again, the communication timeout is automatically cleared, and the NS LED on the driver returns to be lit in green.

If the communication timeout is detected, check the following points.

- Is the EtherNet/IP cable disconnected?
- Is the power supply for the scanner is turned on?

1-2 IP address conflict

If an IP address of the EtherNet/IP compatible products is duplicated in the same system, the IP address conflict is detected.

When the IP address conflict is detected, the NS LED on the driver is lit in red.

If the IP address conflict is detected, change the setting so that an IP address of the EtherNet/IP compatible products is not duplicated.

Check the IP address is not duplicated, and then turn on the control power supply again.

2 Alarms

This driver has the alarm function to protect from temperature rise, poor connection, error in operation, and the like. If an alarm is generated, the ALM-A output is turned ON and the ALM-B output is turned OFF to stop the motor. At the same time, the PWR/ALM LED blinks in red.

Details of the alarm being generated can be checked by counting the number of times the PWR/ALM LED blinks, or using EtherNet/IP or the **MEXE02** software.

2-1 Alarm reset

Before resetting an alarm, always remove the cause of the alarm and ensure safety, and perform one of the reset operations specified below.

- Turn the ALM-RST input ON. (It is enabled at the ON edge of the input.)
- Execute the alarm reset with the maintenance command via EtherNet/IP.
- Execute the alarm reset using the **MEXE02** software.
- Turn off the main power supply and the control power supply, and on again.



- Some alarms cannot be reset by other methods than turning on the main power supply and control power supply again. Refer to “2-4 Alarm list” on p.102.
- An alarm of the absolute position error can be reset if the position preset or return-to-home operation is performed. If it cannot be reset by these methods, the ABZO sensor may be damaged.

2-2 Alarm history

Up to 10 generated alarm items are stored in the non-volatile memory in order of the latest to the oldest. The alarm history stored in the non-volatile memory can be read or cleared if one of the following reset operations is performed.

- Read the alarm history by the monitor command via EtherNet/IP.
- Clear the alarm history by the maintenance command via EtherNet/IP.
- Read or clear the alarm history using the **MEXE02** software.

2-3 Generation condition of alarms

Alarms shown in the table will be generated if the generation condition is exceeded.

| Alarm code | Alarm name | Motor model | Generation condition |
|------------|-----------------------|---------------------------------------|----------------------|
| 21h | Main circuit overheat | – | 85 °C (185 °F) |
| 22h | Overvoltage | – | 36 V *1 63 V *2 |
| 26h | Motor overheat | – | 85 °C (185 °F) |
| 31h | Overspeed | AZM14, AZM15, AZM24, AZM26 | 8,000 r/min |
| | | AZM46, AZM48, AZM66 | 4,500 r/min |
| | | AZM69 | 2,500 r/min |
| 34h | Command pulse error | – | 38,400 r/min |

*1 When the Main power mode is 24 VDC.

*2 When the Main power mode is 48 VDC.

2-4 Alarm list

| Alarm code | Number of times LED blinks | Alarm type | Cause | Remedial action | How to reset | Motor excitation * |
|------------|----------------------------|------------------------------|--|--|--|--------------------|
| 10h | 4 | Excessive position deviation | <ul style="list-style-type: none"> When the motor was in a state of current ON, the deviation between the command position and the feedback position exceeded the value set in the "Excessive position deviation alarm" parameter in the motor shaft. A load is large, or the acceleration/deceleration time or the acceleration/deceleration rate is too short against the load. The operating range of positioning push-motion SD operation was exceeded. | <ul style="list-style-type: none"> Decrease the load. Increase the acceleration/ deceleration time or slow the acceleration/deceleration rate. increase the operating current. Reconsider the operation data. | Any of reset operations | Non-excitation |
| 20h | 5 | Overcurrent | The motor, the cable, and the driver output circuit were short-circuited. | Turn off the main power supply and the control power supply first, and check that the motor, the cable, and the driver are not damaged. After that, turn on the main power supply and the control power supply again. If the alarm is still not reset, the motor, the cable, or the driver may be damaged. Contact your nearest Oriental Motor sales office. | Turn on the main power supply and control power supply again | Non-excitation |
| 21h | 2 | Main circuit overheat | The internal temperature of the driver reached the upper limit of the specification value. | Reconsider the ventilation condition. | Any of reset operations | Non-excitation |
| 22h | 3 | Overvoltage | <ul style="list-style-type: none"> The main power supply voltage exceeded the permissible value. A large load inertia was suddenly stopped. Vertical operation (elevating operation) was performed. | <ul style="list-style-type: none"> Check the input voltage of the main power supply. Decrease the load. Increase the acceleration/ deceleration time or slow the acceleration/deceleration rate. | Any of reset operations | Non-excitation |
| 23h | 3 | Main power supply OFF | The main power supply was shut off during operation. | Check if the main power supply is properly supplied. | Any of reset operations | Non-excitation |
| 25h | 3 | Undervoltage | The main power supply was shut off momentarily or the voltage became low. | Check the input voltage of the main power supply. | Any of reset operations | Non-excitation |
| 26h | 8 | Motor overheat | The detection temperature of the ABZO sensor reached the upper limit of the specification value. | <ul style="list-style-type: none"> Check the heat radiation condition of the motor. Reconsider the ventilation condition. | Any of reset operations | Non-excitation |
| 28h | 8 | Sensor error | An error of the ABZO sensor was detected during operation. | Turn off the main power supply and the control power supply, and check the connection of the motor. After that, turn on the main power supply and the control power supply again. | Turn on the main power supply and control power supply again | Non-excitation |

| Alarm code | Number of times LED blinks | Alarm type | Cause | Remedial action | How to reset | Motor excitation * |
|------------|----------------------------|---------------------------------|---|--|--|--------------------|
| 29h | 9 | CPU peripheral circuit error | <ul style="list-style-type: none"> A temperature significantly higher or lower than the specifications was detected. The driver internal circuit was damaged. | <ul style="list-style-type: none"> Reconsider the ambient temperature and ventilation condition. Turn off the main power supply and the control power supply, and check if the driver is damaged. After that, turn on the main power supply and the control power supply again. If the alarm has still not reset, the driver may be damaged. Contact your nearest Oriental Motor sales office. | Turn on the main power supply and control power supply again | Non-excitation |
| 2Ah | 8 | ABZO sensor communication error | An error was detected in communication between the driver and the ABZO sensor. | Turn off the main power supply and the control power supply, and check the connection of the ABZO sensor. After that, turn on the main power supply and control power supply again. | Turn on the main power supply and control power supply again | Non-excitation |
| 30h | 2 | Overload | A load exceeding the maximum torque was applied for the time exceeded the value set in the "Overload alarm" parameter. | <ul style="list-style-type: none"> Decrease the load. Increase the acceleration/ deceleration time or slow the acceleration/deceleration rate. Increase the operating current. | Any of reset operations | Non-excitation |
| 31h | 2 | Overspeed | The feedback speed of the motor output shaft exceeded the specification value. | <ul style="list-style-type: none"> Reconsider the "Electronic gear A" parameter and the "Electronic gear B" parameter, and set the speed of the motor output shaft to a value lower than the specification value. If an overshoot is occurred at the time of accelerating, increase the acceleration time or slow the acceleration rate. | Any of reset operations | Non-excitation |
| 33h | 7 | Absolute position error | The home information of the ABZO sensor was damaged. | Perform the position preset or return-to-home operation to set the home again. | Turn on the main power supply and control power supply again | Non-excitation |
| 34h | 2 | Command pulse error | The command pulse frequency exceeded the specification value. | Decrease the frequency of the command pulse. | Any of reset operations | Non-excitation |
| 41h | 9 | EEPROM error | The data stored in the driver was damaged. | Initialize all parameters. | Turn on the main power supply and control power supply again | Non-excitation |
| 42h | 8 | Sensor error at power-on | An error of the ABZO sensor was detected when the control power supply was turned on. | Turn off the main power supply and the control power supply, and check the connection of the ABZO sensor. After that, turn on the main power supply and control power supply again. | Turn on the main power supply and control power supply again | Non-excitation |
| 43h | 8 | Rotation error at power on | The motor was being rotated when the control power supply was turned on. | Reconsider the load conditions so that the motor output shaft does not rotate by an external force when the control power supply is turned on. | Turn on the main power supply and control power supply again | Non-excitation |

| Alarm code | Number of times LED blinks | Alarm type | Cause | Remedial action | How to reset | Motor excitation * |
|------------|----------------------------|--------------------------------|---|---|--|--------------------|
| 44h | 8 | Encoder EEPROM error | The data stored in the ABZO sensor was damaged. | Execute either of the following operations. If the same alarm is still generated, the ABZO sensor has been damaged. Contact your nearest Oriental Motor sales office. <ul style="list-style-type: none"> • Set phase Z again with the "ZSG-PRESET" of the maintenance command. • Execute the "Clear tripmeter" of the maintenance command. | Turn on the main power supply and control power supply again | Non-excitation |
| 45h | 8 | Motor combination error | A motor not allowed to combine with the driver was connected. (Refer to p.106 for details.) | Check the motor model and the driver model, and connect them in a correct combination. | Turn on the main power supply and control power supply again | Non-excitation |
| 4Ah | 7 | Return-to-home incomplete | Absolute positioning operation was started in a state where the coordinates had not been set. | Execute the position preset or return-to-home operation. | Any of reset operations | Excitation |
| 60h | 7 | ±LS both sides active | <ul style="list-style-type: none"> • When the "FW-LS/RV-LS input action" parameter is set to "2: Immediate stop with alarm" or "3: Deceleration stop with alarm," both the FW-LS input and the RV-LS input were detected. • Return-to-home operation was executed in a state where both the FW-LS input and the RV-LS input were detected. | Check the sensor logic installed and the "Inverting mode" parameter. | Any of reset operations | Excitation |
| 61h | 7 | Reverse ±LS connection | The LS input opposite to the operating direction was detected while return-to-home operation in the 2-sensor mode or the 3-sensor mode was performed. | Check the wiring of the sensor. | Any of reset operations | Excitation |
| 62h | 7 | Return-to-home operation error | <ul style="list-style-type: none"> • An unanticipated load was applied while return-to-home operation was performed. • The installation positions of the FW-LS and RV-LS sensors and the HOME sensor are near to each other. • Position preset processing upon completion of return-to-home operation was failed. • In return-to-home operation in the one-way rotation mode, the HOME sensor was exceeded while the motor decelerated to a stop. | <ul style="list-style-type: none"> • Check the load. • Reconsider the sensor installation positions and the starting direction of motor operation. • See that a load exceeding the maximum torque is not applied upon completion of return-to-home operation. • Reconsider the specifications of the HOME sensor and the "(HOME) Acceleration/ deceleration" parameter. | Any of reset operations | Excitation |
| 63h | 7 | No HOMES | The HOMES input was not detected at a position between the FW-LS input and the RV-LS input while return-to-home operation in the 3-sensor mode was performed. | Install the HOME sensor at a position between the FW-LS and RV-LS sensors. | Any of reset operations | Excitation |

| Alarm code | Number of times LED blinks | Alarm type | Cause | Remedial action | How to reset | Motor excitation * |
|------------|----------------------------|---------------------------------------|---|---|--|--------------------|
| 64h | 7 | TIM, ZSG, SLIT signal error | None of the TIM output, the ZSG output, or the SLIT input could be detected during return-to-home operation. | <ul style="list-style-type: none"> Reconsider the connection status of the load and the position of the HOME sensor so that these signals should be ON while the HOMES input is ON. When a signal is not used, set the "(HOME) TIM/ZSG signal detection" parameter or the "(HOME) SLIT detection" parameter to "0: Disable." | Any of reset operations | Excitation |
| 66h | 7 | Hardware overtravel | When the "FW-LS/RV-LS input action" parameter is set to "2: Immediate stop with alarm" or "3: Deceleration stop with alarm," the FW-LS input or the RV-LS input was detected. | Reset the alarm and then escape from the sensor by operating the motor or manually. | Any of reset operations | Excitation |
| 67h | 7 | Software overtravel | When the "Software overtravel" parameter is set to "2: Immediate stop with alarm" or "3: Deceleration stop with alarm," the motor position reached the set value of the software limit. | <ul style="list-style-type: none"> Reconsider the operation data. Reset the alarm and then escape from the sensor by operating the motor or manually. | Any of reset operations | Excitation |
| 6Ah | 7 | Return-to-home operation offset error | When offset movement as part of return-to-home operation was performed, the FW-LS input or the RV-LS input was detected. | Check the offset value. | Any of reset operations | Excitation |
| 6Dh | 7 | Mechanical overtravel | The product having set the home reached the mechanism limit stored in the ABZO sensor. | <ul style="list-style-type: none"> Check the travel amount (position). Reset the alarm and then escape from the sensor by operating the motor or manually. | Any of reset operations | Excitation |
| 70h | 7 | Operation data error | <ul style="list-style-type: none"> Stored data operation was performed with data whose operating speed was 0. Operation was performed at the operating speed or operating current exceeding the value set in the "Mechanism protection parameter". Wrap operation was executed when wrap setting was disabled. Push-motion operation or push-motion return-to-home operation was performed with the DGII Series. | <ul style="list-style-type: none"> Check the operation data. Check the value set in the "Mechanism protection parameter" using the unit information monitor of the MEXE02 software. Check the wrap setting. Push-motion operation as well as push-motion return-to-home operation cannot be performed with the DGII Series. | Any of reset operations | Excitation |
| 71h | 7 | Electronic gear setting error | The resolution set in the "Electronic gear A" parameter and "Electronic gear B" parameter were out of the specifications. | Reconsider the "Electronic gear A" parameter and "Electronic gear B" parameter, and set so that the resolution should be in the range of the specifications. | Turn on the main power supply and control power supply again | Non-excitation |
| 72h | 7 | Wrap setting error | The control power supply was turned on in a state where the resolution and the value set in the "Initial coordinate generation & wrap setting range" parameter were inconsistent. | Set the "Initial coordinate generation & wrap setting range" parameter properly, and turn on the main power supply and the control power supply again. | Turn on the main power supply and control power supply again | Non-excitation |

| Alarm code | Number of times LED blinks | Alarm type | Cause | Remedial action | How to reset | Motor excitation * |
|------------|----------------------------|----------------------|---|---|--|--------------------|
| 81h | 7 | Network bus error | Implicit communication of Exclusive Owner connection was disconnected during operation. | Check the connection with the scanner and the condition of the power supply of the scanner. | Any of reset operations | Excitation |
| 82h | 7 | Network module error | An error was detected in the network module. | Turn on the main power supply and the control power supply again. | Turn on the main power supply and control power supply again | Non-excitation |
| F0h | Light | CPU error | CPU malfunctioned. | Turn on the main power supply and the control power supply again. | Turn on the main power supply and control power supply again | Non-excitation |

* An excitation state of the motor when an alarm is generated is as follows.

Non-excitation: If an alarm is generated, the motor current is cut off and the motor holding force is lost. When an electromagnetic brake motor is used, the electromagnetic brake is in a state of holding the motor shaft.

Excitation: Even if an alarm is generated, the motor current is not cut off and the motor position is held.

Related parameters

| Parameter ID | | Parameter name | Description | Initial value |
|--------------|-------|------------------------------------|---|---------------|
| Dec | Hex | | | |
| 384 | 0180h | Overload alarm | Sets the condition in which the overload alarm is generated. [Setting range] 1 to 300 (1=0.1 s) | 50 |
| 385 | 0181h | Excessive position deviation alarm | Sets the condition in which the excessive position deviation alarm is generated. [Setting range] 1 to 30,000 (1=0.01 rev) | 300 |
| 24968 | 6188h | Network bus error alarm | Sets the function of the network bus error alarm. [Setting range] 0: Disable 1: Enable | 1 |

■ About causes of the motor combination error (alarm code 45h)

An alarm of the motor combination error is generated in the following conditions.

- When a motor for the AC power supply was connected to the driver.
- When a motor of frame size 20 mm (0.79 in.) or 28 mm (1.10 in.) was connected to the driver and 48 VDC was applied.

2-5 Timing chart

■ When the motor remains in an excitation state even if an alarm is generated

1. If an error occurs, the ALM-B output and the MOVE output are turned OFF. At the same time, the motor stops instantaneously.
2. When resetting the alarm, turn the operation command OFF. If the alarm is reset while the operation command is input, the motor may start suddenly, causing injury or damage to equipment.
3. Remove the cause of the alarm before turning the ALM-RST input ON. The alarm is reset, and the ALM-B output and the READY output are turned ON.
4. Check the ALM-B output has been turned ON and then turn the ALM-RST input OFF.

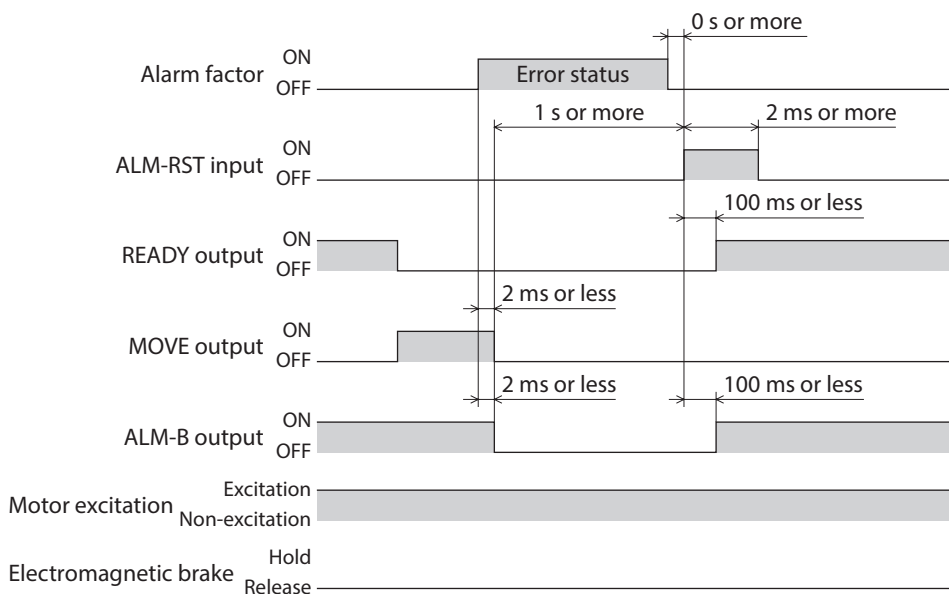
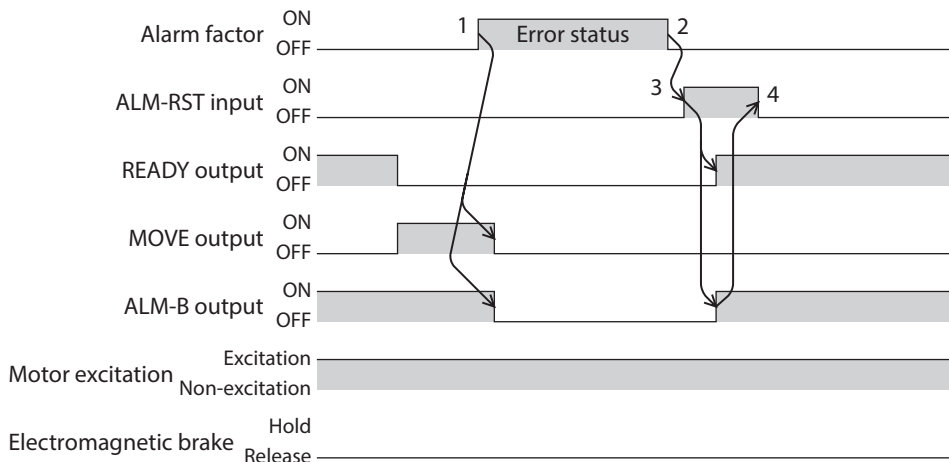

■ When the motor puts into a non-excitation state if an alarm is generated

1. If an error occurs, the ALM-B output and the MOVE output are turned OFF. At the same time, the motor stops instantaneously.
2. When resetting the alarm, turn the operation command OFF. If the alarm is reset while the operation command is input, the motor may start suddenly, causing injury or damage to equipment.
3. Remove the cause of the alarm before turning the ALM-RST input ON. The alarm is reset, and the ALM-B output and the READY output are turned ON.
4. Check the ALM-B output has been turned ON and then turn the ALM-RST input OFF.

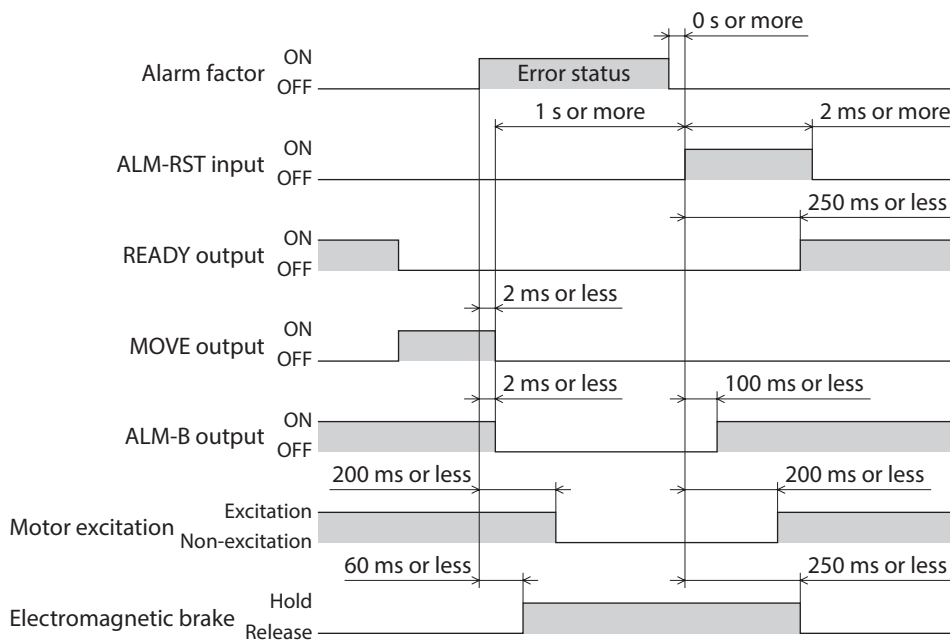
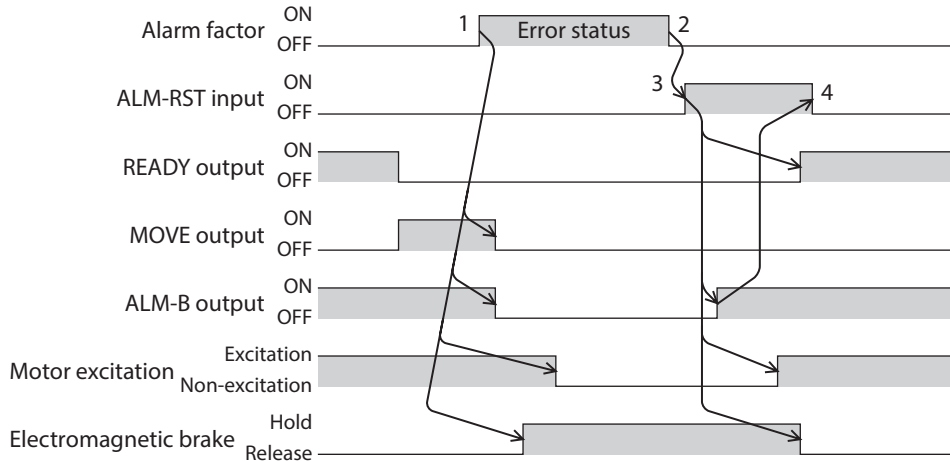

3 Information

The driver is equipped with a function to generate information output before an alarm is generated. This function can be utilized for periodic maintenance of equipment by setting a suitable value in the parameter of each information.

For example, utilizing the "Motor temperature information" parameter can prevent equipment malfunction or production stoppage due to motor overheat. In addition, the "Tripmeter information" parameter can be utilized as a reference to do maintenances every time a certain travel distance is reached.

■ Status when information is generated

● Information bit output

If information is generated, a bit output (INFO-** output) of the corresponding information is turned ON.

A desired output signal can be assigned to the INFO-USRIO output among bit outputs and used. If the assigned output signal is turned ON, the INFO-USRIO output is also turned ON. (Details of bit output → p.112)

● INFO output

If information is generated, the INFO output is turned ON.

● LED indicator

If information is generated, the PWR/ALM LED blinks in blue.

● Operation of motor

The motor continues to operate during information unlike in the case of an alarm.

● Parameter

Each information has a corresponding "INFO action" parameter. If the parameter is set to "0: No Info reflect," only the bit output of information is turned ON, and the INFO output and LED are not changed.

Related parameters

| Parameter ID | | Parameter name | Description | Initial value |
|--------------|-------|--|---|---------------|
| Dec | Hex | | | |
| 416 | 01A0h | Driver temperature information (INFO-DRVTMP) | Sets the condition in which the driver temperature information (INFO-DRVTMP) is generated. [Setting range] 40 to 85 °C | 85 |
| 417 | 01A1h | Overload time information (INFO-OLTIME) | Sets the condition in which the overload time information (INFO-OLTIME) is generated. [Setting range] 1 to 300 (1=0.1 s) | 50 |
| 418 | 01A2h | Speed information (INFO-SPD) | Sets the condition in which the speed information (INFO-SPD) is generated. [Setting range] 0: Disable 1 to 12,000 r/min | 0 |
| 421 | 01A5h | Position deviation information (INFO-POSERR) | Sets the condition in which the position deviation information (INFO-POSERR) is generated. [Setting range] 1 to 30,000 (1=0.01 rev) | 300 |
| 424 | 01A8h | Motor temperature information (INFO-MTRTMP) | Sets the condition in which the motor temperature information (INFO-MTRTMP) is generated. [Setting range] 40 to 120 °C | 85 |
| 427 | 01ABh | Overvoltage information (INFO-OVOLT) | Sets the condition in which the overvoltage information (INFO-OVOLT) is generated. [Setting range] 140 to 630 (1=0.1 V) | 630 |

| Parameter ID | | Parameter name | Description | Initial value |
|--------------|-------|--|---|----------------|
| Dec | Hex | | | |
| 428 | 01ACh | Undervoltage information (INFO-UVOLT) | Sets the condition in which the undervoltage information (INFO-UVOLT) is generated. [Setting range] 140 to 630 (1=0.1 V) | 140 |
| 431 | 01AFh | Tripmeter information (INFO-TRIP) | Sets the condition in which the tripmeter information (INFO-TRIP) is generated. [Setting range] 0: Disable 1 to 2,147,483,647 (1=0.1 kRev) | 0 |
| 432 | 01B0h | Odometer information (INFO-ODO) | Sets the condition in which the odometer information (INFO-ODO) is generated. [Setting range] 0: Disable 1 to 2,147,483,647 (1=0.1 kRev) | 0 |
| 433 | 01B1h | Cumulative load 0 information (INFO-CULD0) | Sets the condition in which the cumulative load 0 information (INFO-CULD0) is generated. [Setting range] 0 to 2,147,483,647 | 0 |
| 434 | 01B2h | Cumulative load 1 information (INFO-CULD1) | Sets the condition in which the cumulative load 1 information (INFO-CULD1) is generated. [Setting range] 0 to 2,147,483,647 | 0 |
| 435 | 01B3h | Cumulative load value auto clear | Clears the cumulative load when operation is started (at the ON edge of the MOVE output). [Setting range] 0: Not clear 1: Clear | 1 |
| 436 | 01B4h | Cumulative load value count divisor | Sets the divisor of the cumulative load. [Setting range] 1 to 32,767 | 1 |
| 444 | 01BCh | INFO-USRIO output selection | Selects the output signal to be checked in the INFO-USRIO output. [Setting range] Output signal ⇨ p.97 | 128: CONST-OFF |
| 445 | 01BDh | INFO-USRIO output inversion | Sets the output logic of the INFO-USRIO output. [Setting range] 0: Not invert 1: Invert | 0 |
| 446 | 01BEh | Information LED condition | Sets the LED status when information is generated. [Setting range] 0: Disable (LED does not blink) 1: Enable (LED blinks) | 1 |
| 447 | 01BFh | Information auto clear | When the cause of information is eliminated, the INFO output and the bit output of the corresponding information are turned OFF automatically. [Setting range] 0: Disable (not turned OFF automatically) 1: Enable (turned OFF automatically) | 1 |

| Parameter ID | | Parameter name | Description | Initial value |
|--------------|-------|---|---|---------------|
| Dec | Hex | | | |
| 1952 | 07A0h | INFO action (Assigned I/O status information (INFO-USRIO)) | Sets the bit output, the INFO output, and the LED status when information is generated. [Setting range] 0: No info reflect (Only the bit output is ON.) 1: Info reflect (The bit output and the INFO output are ON and the LED blinks.) | 1 |
| 1953 | 07A1h | INFO action (Position deviation information (INFO-POSERR)) | | |
| 1954 | 07A2h | INFO action (Driver temperature information (INFO-DRVTMP)) | | |
| 1955 | 07A3h | INFO action (Motor temperature information (INFO-MTRTMP)) | | |
| 1956 | 07A4h | INFO action (Overvoltage information (INFO-OVOLT)) | | |
| 1957 | 07A5h | INFO action (Undervoltage information (INFO-UVOLT)) | | |
| 1958 | 07A6h | INFO action (Overload time information (INFO-OLTIME)) | | |
| 1960 | 07A8h | INFO action (Speed information (INFO-SPD)) | | |
| 1961 | 07A9h | INFO action (Start operation error information (INFO-START)) | | |
| 1962 | 07AAh | INFO action (Start ZHOME error information (INFO-ZHOME)) | | |
| 1963 | 07ABh | INFO action (PRESET request information (INFO-PR-REQ)) | | |
| 1965 | 07ADh | INFO action (Electronic gear setting error information (INFO-EGR-E)) | | |
| 1966 | 07AEh | INFO action (Wrap setting error information (INFO-RND-E)) | | |
| 1968 | 07B0h | INFO action (Forward operation prohibition information (INFO-FW-OT)) | | |
| 1969 | 07B1h | INFO action (Reverse operation prohibition information (INFO-RV-OT)) | | |
| 1970 | 07B2h | INFO action (Cumulative load 0 information (INFO-CULD0)) | | |
| 1971 | 07B3h | INFO action (Cumulative load 1 information (INFO-CULD1)) | | |
| 1972 | 07B4h | INFO action (Tripmeter information (INFO-TRIP)) | | |
| 1973 | 07B5h | INFO action (Odometer information (INFO-ODO)) | | |
| 1980 | 07BCh | INFO action (Start operation restricted mode information (INFO-DSLMTD)) | | |
| 1981 | 07BDh | INFO action (I/O test mode information (INFO-IOTEST)) | | |
| 1982 | 07BEh | INFO action (Configuration request information (INFO-CFG)) | | |
| 1983 | 07BFh | INFO action (Reboot request information (INFO-RBT)) | | |

3-1 Information history

Up to 16 generated information items are stored in the RAM in order of the latest to the oldest. Information items stored as the information history are the information code, generation time, and contents of information. The information history stored in the RAM can be read or cleared if one of the following is performed.

- Read the information history by the monitor command via EtherNet/IP.
- Clear the information history by the maintenance command via EtherNet/IP.
- Read or clear the information history using the **MEXE02** software.



Information history is cleared when the main power supply and control power supply of the driver are turned off because it is stored in the RAM.

3-2 Information list

| Information item | Information bit output signal | Cause | Reset condition |
|---------------------|-------------------------------|--|--|
| Assigned I/O status | INFO-USRIO | The I/O signal set in the "INFO-USRIO output selection" parameter was turned ON. | The I/O signal set in the "INFO-USRIO output selection" parameter was turned OFF. |
| Position deviation | INFO-POSERR | The deviation between the command position and the feedback position exceeded the value set in the "Position deviation information" parameter in the motor output shaft. | The deviation between the command position and the feedback position fell below the value set in the "Position deviation information" parameter in the motor output shaft. |
| Driver temperature | INFO-DRVTMP | The internal temperature of the driver exceeded the value set in the "Driver temperature information" parameter. | The internal temperature of the driver fell below the value set in the "Driver temperature information" parameter. |
| Motor temperature | INFO-MTRTMP | The detection temperature of the encoder exceeded the value set in the "Motor temperature information" parameter. | The detection temperature of the encoder fell below the value set in the "Motor temperature information" parameter. |
| Overvoltage | INFO-OVOLT | <ul style="list-style-type: none"> • The voltage of the main power supply exceeded the value set in the "Overvoltage information" parameter. • A large load inertia was suddenly stopped. • Vertical operation (elevating operation) was performed. | The voltage of the main power supply fell below the value set in the "Overvoltage information" parameter. |
| Undervoltage | INFO-UVOLT | <ul style="list-style-type: none"> • The voltage of the main power supply fell below the value set in the "Undervoltage information" parameter. • The main power supply was shut off momentarily or a voltage was insufficient. | The voltage of the main power supply exceeded the value set in the "Undervoltage information" parameter. |
| Overload time | INFO-OLTIME | A load exceeding the maximum torque was applied for a time period exceeding the value set in the "Overload time information" parameter. | The overload counter fell below the value set in the "Overload time information" parameter. |
| Speed | INFO-SPD | The feedback speed of the motor exceeded the value set in the "Speed information" parameter. | The feedback speed of the motor fell below the value set in the "Speed information" parameter. |

| Information item | Information bit output signal | Cause | Reset condition |
|-------------------------------|-------------------------------|--|--|
| Start operation error | INFO-START | <ul style="list-style-type: none"> • The operation start signal in the direction having been stopped by the FW-BLK input or RV-BLK input was turned ON. • The operation start signal in the direction having been stopped by the FW-LS input or RV-LS input was turned ON. • The operation start signal in the direction having been stopped by the software limit was turned ON. • When operation could not be executed (e.g., the READY output was OFF), the operation start signal was turned ON. | Operation was started properly. |
| Start ZHOME error | INFO-ZHOME | <ul style="list-style-type: none"> • When the coordinates were not set (the ABSPEN output was OFF), the ZHOME input was turned ON. • When the motor was used with the electrical home coordinate system (the EL-PRST input was ON), return-to-home operation was performed. | Operation was started properly. |
| Preset request | INFO-PR-REQ | Preset was executed by the position preset or return-to-home operation. | Preset was completed. |
| Electronic gear setting error | INFO-EGR-E | The resolution set in the "Electronic gear A" parameter and "Electronic gear B" parameter was out of the specifications. | The resolution was set in the range of the specifications. |
| Wrap setting error | INFO-RND-E | The resolution and the "Initial coordinate generation & wrap setting range" parameter were inconsistent. | The "Initial coordinate generation & wrap setting range" parameter was set in the range of the specifications. |
| Forward operation prohibition | INFO-FW-OT | <ul style="list-style-type: none"> • The positive software limit was exceeded. • Either the FW-LS input or the FW-BLK input was turned ON. | The position of the motor was in the range of the positive software limit, and in addition, both the FW-LS input and the FW-BLK input were turned OFF. |
| Reverse operation prohibition | INFO-RV-OT | <ul style="list-style-type: none"> • The negative software limit was exceeded. • Either the RV-LS input or the RV-BLK input was turned ON. | The position of the motor was in the range of the negative software limit, and in addition, both the RV-LS input and the RV-BLK input were turned OFF. |
| Cumulative load 0 | INFO-CULD0 | The cumulative load exceeded the value set in the "Cumulative load 0 information" parameter. | The cumulative load fell below the value set in the "Cumulative load 0 information" parameter. |
| Cumulative load 1 | INFO-CULD1 | The cumulative load exceeded the value set in the "Cumulative load 1 information" parameter. | The cumulative load fell below the value set in the "Cumulative load 1 information" parameter. |
| Tripmeter | INFO-TRIP | The travel distance of the motor exceeded the value set in the "Tripmeter information" parameter. | <p>After one of the following operations was performed, the travel distance (Tripmeter) of the motor fell below the value set in the "Tripmeter information" parameter.</p> <ul style="list-style-type: none"> • The "Tripmeter information" parameter was set again. • The "Clear tripmeter" of the maintenance command was executed. |

| Information item | Information bit output signal | Cause | Reset condition |
|---------------------------------|-------------------------------|---|--|
| Odometer | INFO-ODO | The cumulative travel distance of the motor exceeded the value set in the "Odometer information" parameter. | After the following operation was performed, the cumulative travel distance (Odometer) of the motor fell below the value set in the "Odometer information" parameter. The "Odometer information" parameter was set again. |
| Start operation restricted mode | INFO-DSLMTD | <ul style="list-style-type: none"> • "Teaching, remote operation" was executed using the MEXE02 software. • Configuration was executed. • Data was written to the driver from the MEXE02 software. • "Restored to the factory setting" was executed using the MEXE02 software. | <ul style="list-style-type: none"> • Teaching, remote operation was released. • Configuration was completed. • Writing data was completed. • Data was restored to the factory setting. |
| I/O test mode | INFO-IOTEST | <ul style="list-style-type: none"> • "I/O test" was executed with the MEXE02 software. • Configuration was executed. | <ul style="list-style-type: none"> • The I/O test mode was canceled. • Configuration was completed. |
| Configuration request | INFO-CFG | The parameter that required executing the configuration was changed. | Configuration was executed. |
| Reboot request | INFO-RBT | The parameter that required rebooting was changed. | Reboot was executed. |



If the "Preset request" information was generated for 100 ms or more in a state where the "Information auto clear" parameter was set to disable, the preset may have been failed. There are the following two possible reasons that the preset was failed.

- The ABZO sensor is not connected to the driver.
- The preset was executed in a state where the position deviation between the command position and the feedback position was 1.8° or more.

4 Troubleshooting and remedial actions

In motor operation, the motor or the driver may not operate properly due to an improper setting or wrong connection.

When the motor operation cannot be performed properly, refer to the contents provided in this chapter and take an appropriate remedial action.

If the problem persists, contact your nearest Oriental Motor sales office.

| Phenomenon | Possible cause | Remedial action |
|---|---|--|
| <ul style="list-style-type: none"> • The motor is not excited. • The motor output shaft can be rotated by hand. | Connection error of the motor cable | Check the motor connection. |
| | The FREE input is being ON. | Turn the FREE input OFF. |
| The motor has a holding torque even if it puts into a non-excitation state. | Effect of dynamic brake. | If the motor puts into a non-excitation state, the motor windings are brought into a state of being short-circuited inside the driver, generating a larger holding torque than when no current is supplied (dynamic brake). To release the dynamic brake, shut off the main power supply and control power supply or turn the FREE input ON. |
| The motor does not rotate. | When an electromagnetic brake motor is used, the electromagnetic brake is in a holding state. | <ul style="list-style-type: none"> • Check the connection of the electromagnetic brake. • Check the input voltage of the control power supply. |
| | The position (travel amount) is not set in the operation data when positioning operation is performed. | Check the operation data. |
| | When JOG operation, high-speed JOG operation, or continuous macro operation is performed, the input in the forward direction and that in the reverse direction are simultaneously ON. | Turn both inputs in the forward direction and the reverse direction OFF, and then turn either one ON. |
| | The STOP input is being ON. | Turn the STOP input OFF. |
| The motor rotates in the direction opposite to the specified direction. | The "Motor rotation direction" parameter is set wrongly. | Check the setting of the "Motor rotation direction" parameter. |
| The gearhead output shaft rotates in the direction opposite to the motor. | A geared motor that rotates in the direction opposite to the motor output shaft is used. | <ul style="list-style-type: none"> • With the TS geared type, the gearhead output shaft rotates in the direction opposite to the motor when the gear ratio is 20 or 30. • With the Harmonic geared type, the gearhead output shaft always rotates in the direction opposite to the motor. |
| Motor operation is unstable. | Connection error of the motor cable or power supply cable. | Check the connections between the driver, motor and power supply. |
| | A value set in the "Base current" parameter is too low. | Check the setting of the "Base current" parameter. If the motor current value is low with respect to a load, the torque will also be low and the operation will be unstable. |
| | The "Main power mode" parameter is set wrongly. | Check the setting of the "Main power mode" parameter. |
| | The main power supply starts up slowly or the voltage of the main power supply is unstable. | Set the "Main power mode" parameter to "0: 24 VDC" or "1: 48 VDC" according to the rated voltage of the main power supply. |

| Phenomenon | Possible cause | Remedial action |
|---|---|---|
| Motor vibration is too large. | The load is small. | Lower the current with the "Base current" parameter. If the motor output torque is too large with respect to a load, vibration will increase. |
| | The "Main power mode" parameter is set wrongly. | Check the setting of the "Main power mode" parameter. |
| | The main power supply starts up slowly or the voltage of the main power supply is unstable. | Set the "Main power mode" parameter to "0: 24 VDC" or "1: 48 VDC" according to the rated voltage of the main power supply. |
| The electromagnetic brake is not put into a state of releasing the motor shaft. | The power is not supplied to the electromagnetic brake. | Check the connection of the electromagnetic brake. |
| | A voltage for the electromagnetic brake is insufficient. | Check the input voltage of the control power supply. |



Check the alarm message using EtherNet/IP or the **MEXE02** when the alarm is being generated.

6 Reference materials

◆ Table of contents

| | | |
|----------|---------------------------------------|------------|
| 1 | Timing chart | 118 |
| 2 | Specifications | 120 |
| | 2-1 Product specifications..... | 120 |
| | 2-2 General specifications..... | 120 |
| 3 | Regulations and standards..... | 121 |



1 Timing chart

■ Power activation

● When a control power supply is used

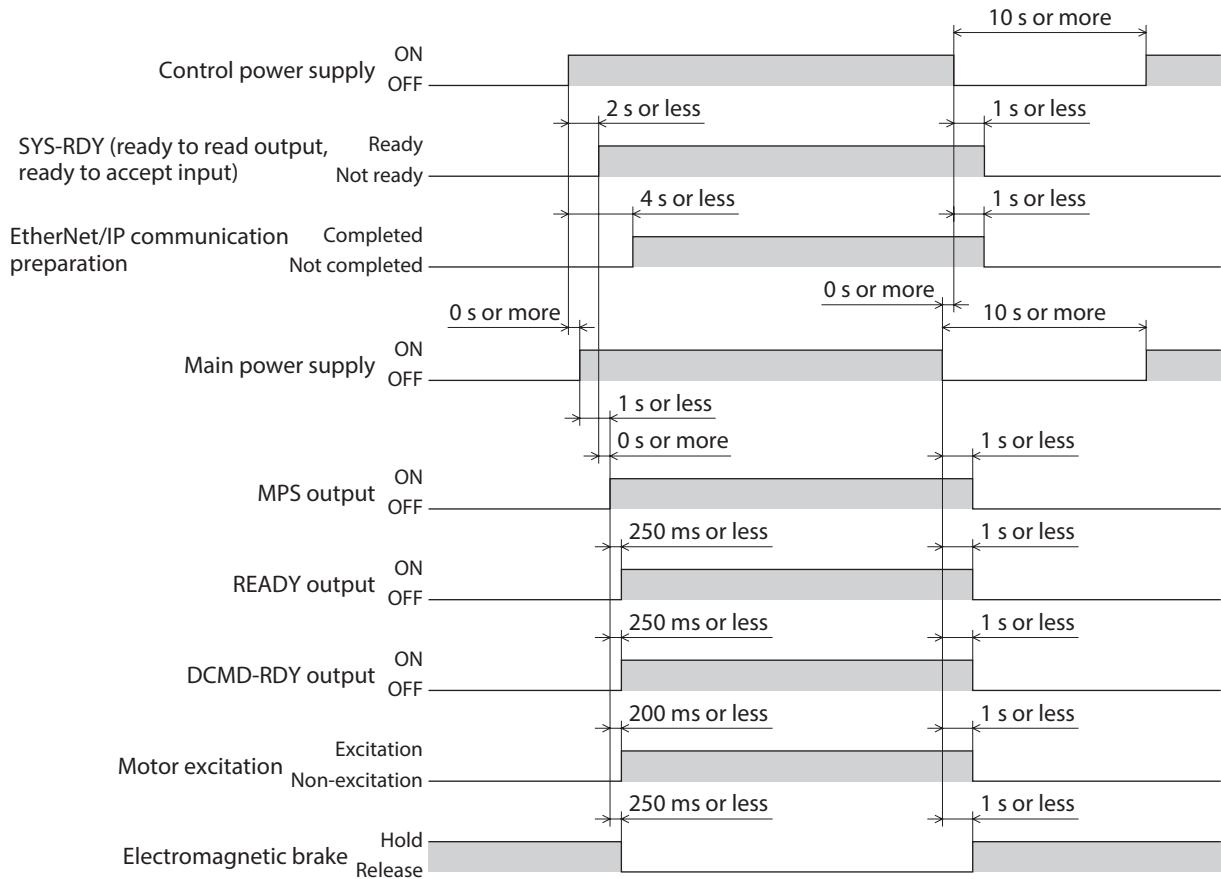

● When a control power supply is not used

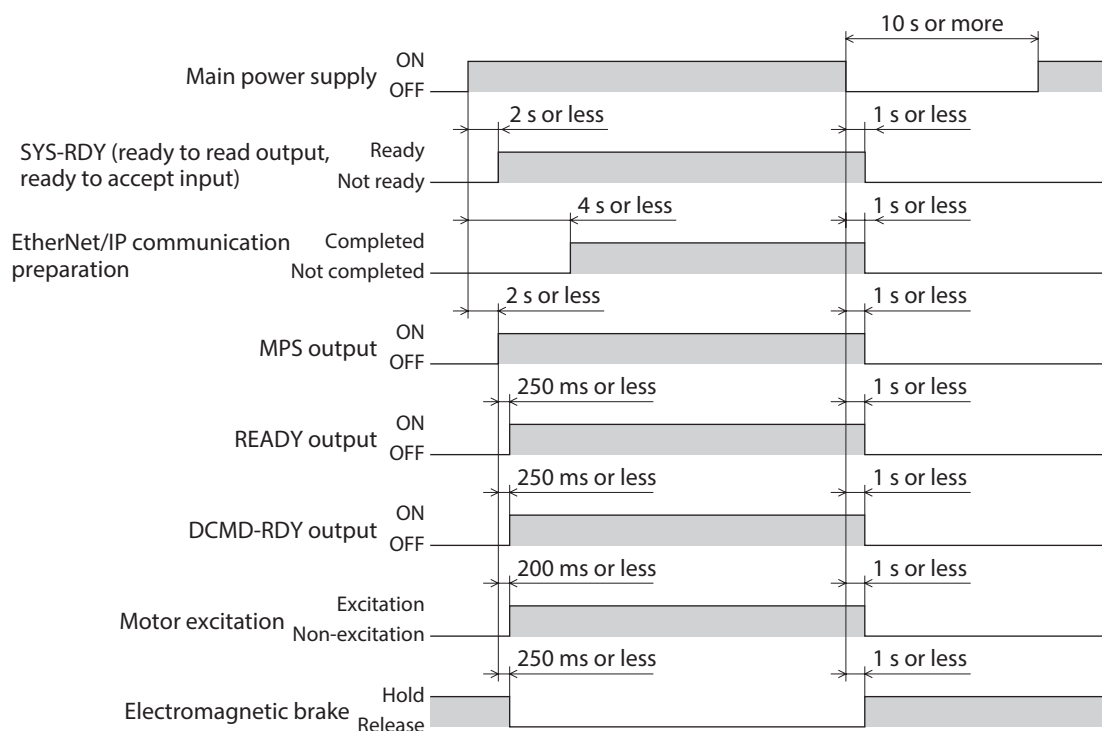

2 Specifications

2-1 Product specifications

| | | |
|----------------------|-----------------------------|--|
| Main power supply | Rated voltage | 24 VDC±5 % 48 VDC±5 % |
| | Input current | 0.4 to 3.7 A *1 |
| | Allowable operating voltage | 24 VDC input: 20 to 32 VDC (22.8 to 32 VDC) *2 48 VDC input: 40 to 55 VDC |
| Control power supply | Rated voltage | 24 VDC±5 % 48 VDC±5 % |
| | Input current | 0.15 A (0.4 A) *3 |
| | Allowable operating voltage | 24 VDC input: 20 to 32 VDC (22.8 to 32 VDC) *2 48 VDC input: 40 to 55 VDC |
| Interface | Control input | 20 to 32 VDC Number of input points: 2, photocoupler |
| | Field network | EtherNet/IP |

- *1 The input current varies depending on the motor combined. Check on p.25.
- *2 The value in parentheses () is the one when the electromagnetic brake motor is connected.
- *3 The value in parentheses () is the one when the electromagnetic brake motor is connected. The **AZM46** type is 0.23 A.

2-2 General specifications

| | | |
|---|------------------------|--|
| Degree of protection | | IP20 |
| Operating environment | Ambient temperature | 0 to +50 °C [+32 to +122 °F] (non-freezing) |
| | Humidity | 85 % or less (non-condensing) |
| | Altitude | Up to 1,000 m (3,300 ft.) above sea level |
| | Surrounding atmosphere | No corrosive gas, dust, water or oil |
| Storage environment Shipping environment | Ambient temperature | -25 to +70 °C [-13 to 158 °F] (non-freezing) |
| | Humidity | 85 % or less (non-condensing) |
| | Altitude | Up to 3,000 m (10,000 ft.) above sea level |
| | Surrounding atmosphere | No corrosive gas, dust, water or oil |

3 Regulations and standards

■ UL Standards, CSA Standards

This product is recognized by UL under the UL and CSA Standards.
Check the "APPENDIX UL Standards for **AZ** Series" for recognition information about UL Standards.

■ CE Marking / UKCA Marking

This product is affixed with the marks under the following directives/regulations.

● EU EMC Directive / UK EMC Regulation

Refer to "4-7 Conformity to EMC Directive/Regulations" on p.28 for details about conformity.

● EU RoHS Directive/UK RoHS Regulation

This product does not contain the substances exceeding the restriction values.

■ Republic of Korea, Radio Waves Act

This product is affixed with the KC Mark under the Radio Waves Act, the Republic of Korea.

- Unauthorized reproduction or copying of all or part of this manual is prohibited.
If a new copy is required to replace an original manual that has been damaged or lost, please contact your nearest Oriental Motor sales office.
- Oriental Motor shall not be liable whatsoever for any problems relating to industrial property rights arising from use of any information, circuit, equipment or device provided or referenced in this manual.
- Characteristics, specifications and dimensions are subject to change without notice.
- While we make every effort to offer accurate information in the manual, we welcome your input. Should you find unclear descriptions, errors or omissions, please contact the nearest office.
- **Oriental motor**, **αSTEP**, and ABZO sensor are registered trademarks or trademarks of Oriental Motor Co., Ltd., in Japan and other countries.
EtherNet/IP™ is a trademark of ODVA (Open DeviceNet Vendor Association).
Other product names and company names mentioned in this manual may be registered trademarks or trademarks of their respective companies and are hereby acknowledged. The third-party products mentioned in this manual are recommended products, and references to their names shall not be construed as any form of performance guarantee. Oriental Motor is not liable whatsoever for the performance of these third-party products.

© Copyright ORIENTAL MOTOR CO., LTD. 2022

Published in November 2023

- Please contact your nearest Oriental Motor office for further information.

ORIENTAL MOTOR U.S.A. CORP.
Technical Support Tel:800-468-3982
8:30am EST to 5:00pm PST (M-F)

ORIENTAL MOTOR (EUROPA) GmbH
Schiebsstraße 44, 40549 Düsseldorf, Germany
Technical Support Tel:00 800/22 55 66 22

ORIENTAL MOTOR (UK) LTD.
Unit 5 Faraday Office Park, Rankine Road,
Basingstoke, Hampshire RG24 8QB UK
Tel:+44-1256347090

ORIENTAL MOTOR (FRANCE) SARL
Tel:+33-1 47 86 97 50

ORIENTAL MOTOR ITALIA s.r.l.
Tel:+39-02-93906347

ORIENTAL MOTOR ASIA PACIFIC PTE. LTD.
Singapore
Tel:1800-842-0280

ORIENTAL MOTOR (MALAYSIA) SDN. BHD.
Tel:1800-806-161

ORIENTAL MOTOR (THAILAND) CO., LTD.
Tel:1800-888-881

ORIENTAL MOTOR (INDIA) PVT. LTD.
Tel:1800-120-1995 (For English)
1800-121-4149 (For Hindi)

TAIWAN ORIENTAL MOTOR CO., LTD.
Tel:0800-060708

SHANGHAI ORIENTAL MOTOR CO., LTD.
Tel:400-820-6516

INA ORIENTAL MOTOR CO., LTD.
Korea
Tel:080-777-2042

ORIENTAL MOTOR CO., LTD.
4-8-1 Higashiueno, Taito-ku, Tokyo
110-8536 Japan
Tel:+81-3-6744-0361
www.orientalmotor.co.jp/ja