

αSTEP

AZ Series / Motorized Actuator

equipped with AZ Series

mini Driver

PROFINET Compatible

USER MANUAL

Introduction

Hardware

PROFINET
communication

Parameter ID lists

Troubleshooting

Reference materials

Thank you for purchasing an Oriental Motor product.

This Manual describes product handling procedures and safety precautions.

- Please read it thoroughly to ensure safe operation.
- Always keep the manual where it is readily available.

1 Introduction

1	Before using the product.....	6
2	Operating manuals	7
2-1	Related operating manuals.....	7
2-2	How to use operating manuals.....	7
3	Overview of the product.....	9
4	Safety precautions	10
5	Precautions for use	12

2 Hardware

1	System configuration	16
2	Preparation.....	17
2-1	Checking the product.....	17
2-2	How to identify the product model	17
2-3	Products possible to combine	17
2-4	Information about nameplate	18
2-5	Names and functions of parts	18
2-6	Indication of LEDs.....	19
3	Installation.....	21
3-1	Installation location	21
3-2	Installation method.....	21
4	Connection	23
4-1	Connection example	23
4-2	Connecting the main power supply and the control power supply (CN1).....	24
4-3	Connecting the PROFINET cable (CN3/CN4).....	26
4-4	Connecting the USB cable.....	26
4-5	Connecting input signals (CN5).....	26
4-6	Noise elimination measures.....	28
4-7	Compliance with the EMC Directive/Regulations.....	28
5	Inspection and maintenance	30
5-1	Inspection.....	30
5-2	Warranty.....	30
5-3	Disposal	30
6	Cables	31
6-1	Connection cables (For cable type).....	31
6-2	Connection cables (For connector type).....	34
6-3	Power supply cable	35

3 PROFINET communication

1	Flow of setting of PROFINET communication.....	38
2	Guidance.....	39
3	Communication specifications.....	41
4	IO data.....	42
4-1	IO data format.....	42
4-2	Input data.....	43
4-3	Output data.....	48
4-4	Processing order of IO data.....	52
4-5	Data writing.....	53
4-6	Data reading.....	54
5	Example of execution for operation.....	56
5-1	Positioning operation.....	56
5-2	Continuous operation.....	57
6	Direct data operation.....	58
6-1	Overview of direct data operation.....	58
6-2	Output data and parameters required for direct data operation.....	59
6-3	Operation example.....	62

4 Parameter ID lists

1	Timing for parameter to update.....	66
2	Maintenance commands.....	67
3	Monitor commands.....	69
4	Operation data R/W commands.....	75
4-1	Base address of each operation data number.....	75
4-2	Parameter ID.....	77
4-3	Setting example.....	78
5	Operation I/O event R/W commands.....	79
5-1	Base address of operation I/O event.....	79
5-2	Parameter ID for operation I/O event R/W command.....	79
6	Protect release commands.....	80
7	Extended operation data setting R/W command.....	81
8	Parameter R/W commands.....	82
8-1	Driver action simulation setting parameter.....	82
8-2	Base setting parameter.....	82
8-3	Coordinate parameters.....	83
8-4	Operation parameters.....	83
8-5	Direct data operation parameters.....	83
8-6	ABZO sensor setting parameters.....	84
8-7	Mechanism settings parameters.....	84
8-8	Initial coordinate generation & wrap coordinate parameters.....	84

8-9	JOG/HOME/ZHOME operation information setting parameters.....	85
8-10	Alarm setting parameters.....	86
8-11	Information setting parameters.....	86
8-12	I/O parameters.....	88
8-13	Direct I/O setting parameters.....	91
8-14	Remote I/O setting parameters.....	91
8-15	Virtual input parameters.....	92
8-16	User output setting parameters.....	93
8-17	Driver mode setting parameters.....	93
8-18	Assignable monitor setting parameters.....	93
9	I/O signals assignment list.....	94
9-1	Input signals.....	94
9-2	Output signals.....	95

5 Troubleshooting

1	Detection of communication errors.....	98
1-1	Communication timeout.....	98
1-2	Error of communication settings.....	98
2	Alarms.....	99
2-1	Alarm reset.....	99
2-2	Alarm history.....	99
2-3	Generation condition of alarms.....	99
2-4	Alarm list.....	100
2-5	Timing chart.....	105
3	Information.....	107
3-1	Information history.....	110
3-2	Information list.....	110
4	Troubleshooting and remedial actions.....	113

6 Reference materials

1	Timing chart.....	116
2	Specifications.....	118
2-1	Product specifications.....	118
2-2	General specifications.....	118
3	Regulations and standards.....	119

1 Introduction



This part explains the product overview and safety precautions in addition to the types and descriptions about operating manuals.

◆ Table of contents

1	Before using the product	6
2	Operating manuals	7
	2-1 Related operating manuals.....	7
	2-2 How to use operating manuals	7
3	Overview of the product.....	9
4	Safety precautions	10
5	Precautions for use.....	12

1 Before using the product

Only qualified personnel of electrical and mechanical engineering should work with the product. Use the product correctly after thoroughly reading the section "4 Safety precautions" on p.10. In addition, be sure to observe the contents described in warning, caution, and note in this manual. The product described in this document has been designed and manufactured to be incorporated in general industrial equipment. Do not use for any other purpose. Oriental Motor Co., Ltd. is not responsible for any compensation for damage caused through failure to observe this warning.

2 Operating manuals

2-1 Related operating manuals

Download the operating manuals from Oriental Motor Website Download Page or contact your nearest Oriental Motor sales office.

- **AZ** Series / Motorized Actuator equipped with **AZ** Series mini Driver PROFINET Compatible USER MANUAL (this document)
- **AZ** Series / Motorized Actuator equipped with **AZ** Series OPERATING MANUAL Function Edition

Read the following operating manuals for motors and motorized actuators.

- OPERATING MANUAL Motor Edition
- OPERATING MANUAL Actuator Edition
- Motorized Actuator OPERATING MANUAL Function Setting Edition

2-2 How to use operating manuals

To use the product, read this manual together with the **AZ** Series OPERATING MANUAL Function Edition. This manual describes contents specific to the mini Driver PROFINET compatible, and the **AZ** Series OPERATING MANUAL Function Edition describes contents common to the **AZ** Series products. Refer to the **AZ** Series OPERATING MANUAL Function Edition for the contents not included in this manual.

Reference destinations are indicated according to the flow of use.

■ How to read reference destinations

The title name of the operating manual is described in the reference destination.



The title number in the reference destination may be changed. Use the title name when checking the reference destination.

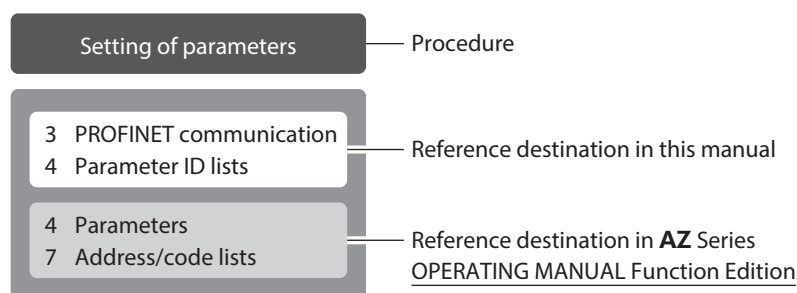

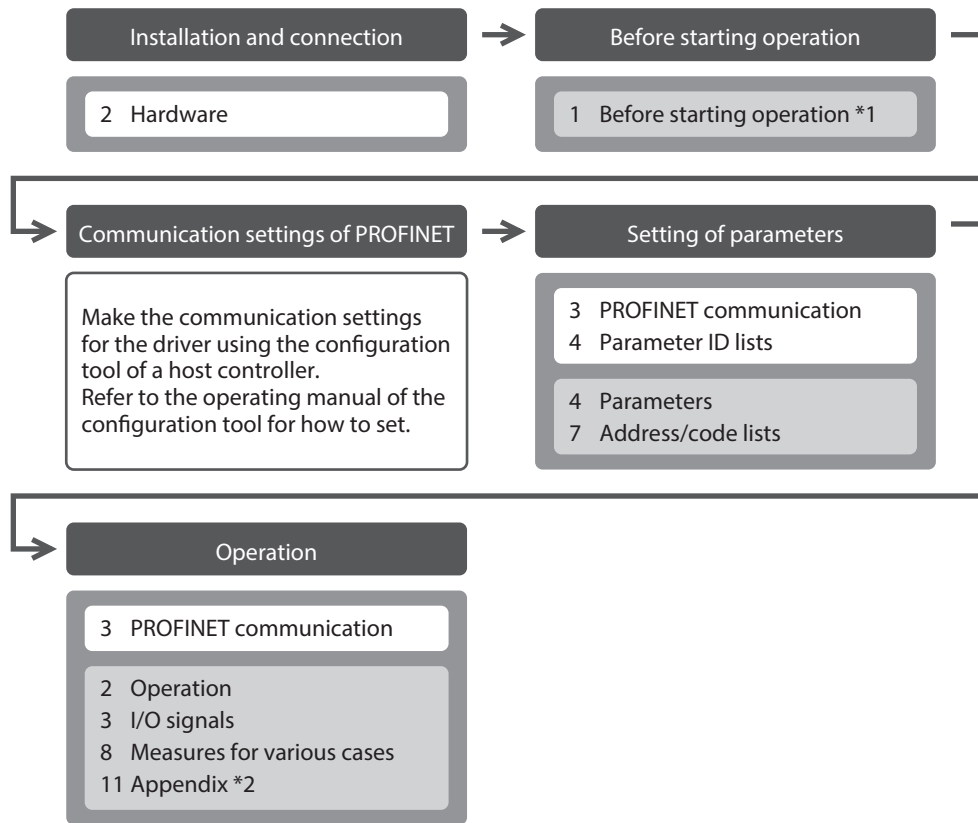

*1 When a motorized actuator is used, the following contents cannot be operated via PROFINET. Use the support software **MEXE02**.

- Copying the fixed value (parameter) of the ABZO sensor to driver
- Creation of recovery data file and method of recovery

*2 Refer to this manual for "LEDs of the driver." (⇒ p.19)

■ Description of power supplies

This manual describes contents when a main power supply and a control power supply are used.

The mini Driver can also be used with a main power supply only. When using it with only the main power supply, replace "main power supply and control power supply" or "control power supply" with "main power supply" to read this manual.

3 Overview of the product

The **AZ** Series mini Driver PROFINET compatible is the dedicated driver for the **AZ** Series products.

■ Compact and light weight

Compact and lightweight are achieved, offering the dimensions of 69 mm×56 mm×30 mm (2.72 in.×2.2 in.×1.18 in.) and the mass of 0.11 kg (0.24 lb.).

■ Compatible with PROFINET

Operation data and parameters can be set via PROFINET or using the **MEXE02** software. This manual describes how to set operation data and parameters via PROFINET.

■ Equipped with direct data operation function

Direct data operation is a function to start operation at the same time as rewriting of the data. It can be used when the setting of the operation data is changed frequently, such as changing the speed or travel amount according to a load.





■ Providing the GSD File

The GSD file (General Station Description file) is a file that describes the specific information of the PROFINET compatible products. Importing the GSD file to the Configuration tool of the host controller can perform the settings of PROFINET before the driver is delivered to you.

For details, contact your nearest Oriental Motor sales office.

4 Safety precautions

The precautions described below are intended to ensure the safe and correct use of the product, and to prevent the user and other personnel from exposure to the risk of injury. Use the product only after carefully reading and fully understanding these instructions.

 WARNING	Handling the product without observing the instructions that accompany a "WARNING" symbol may result in serious injury or death.
 CAUTION	Handling the product without observing the instructions that accompany a "CAUTION" symbol may result in injury or property damage.
	The items under this heading contain important handling instructions that the user should observe to ensure safe use of the product.
	The items under this heading contain related information and contents to gain a further understanding of the text in this manual.

WARNING

General

- Do not use the product in explosive or corrosive environments, in the presence of flammable gases, in places subjected to splashing water, or near combustibles. Doing so may result in fire, electric shock, or injury.
- Assign qualified personnel to the task of installing, wiring, operating/controlling, inspecting and troubleshooting the product. Handling by unqualified personnel may result in fire, electric shock, injury, or damage to equipment.
- Do not transport, install, connect or inspect the product while the power is supplied. Doing so may result in electric shock.
- Do not touch the driver while the power is supplied. Doing so may result in fire or electric shock.
- When an alarm of the driver is generated (any of the driver's protective functions is triggered), remove the cause before resetting the alarm (protective function). Continuing the operation without removing the cause of the problem may cause malfunction of the motor and the driver, leading to injury or damage to equipment.

Installation

- Install the driver in an enclosure. Failure to do so may result in electric shock or injury.

Connection

- Observe the product specifications for the power supply voltage of the driver. Failure to do so may result in fire or electric shock.
- Connect the product securely according to the connection diagram. Failure to do so may result in fire or electric shock.
- Do not forcibly bend, pull, or pinch the connection cable. Doing so may result in fire or electric shock.

Operation

- Turn off the main power supply and the control power supply in the event of a power failure. Failure to do so may result in injury or damage to equipment.
- Do not remove the motor excitation during operation. Doing so may cause the motor to stop and lose the holding force, resulting in injury or damage to equipment.

Repair, disassembly, and modification

- Do not disassemble or modify the driver. Doing so may result in injury or damage to equipment.

 **CAUTION****General**

- Do not use the driver beyond the specifications. Doing so may result in electric shock, injury, or damage to equipment.
- Keep your fingers and objects out of the openings in the driver. Failure to do so may result in fire, electrical shock, or injury.
- Do not touch the driver while operating or immediately after stopping. Doing so may result in a skin burn(s).
- Do not forcibly bend or pull the cable that is connected to the driver. Doing so may cause damage to the product.

Installation

- Keep the area around the driver free of combustible materials. Failure to do so may result in fire or a skin burn(s).
- Do not leave anything around the driver that would obstruct ventilation. Doing so may result in damage to equipment.

Operation

- Use a motor and a driver only in the specified combination. An incorrect combination may cause a fire.
- Take measures against static electricity when operating the switches of the driver. Failure to do so may result in the driver malfunction or damage to equipment.
- Provide an emergency-stop device or emergency-stop circuit external to the equipment so that the entire equipment will operate safely in the event of a system failure or malfunction. Failure to do so may result in injury.
- When moving the moving part manually, put the motor into a non-excitation state. Continuing the work while the motor is in an excitation state may result in injury.
- For the main power supply and the control power supply, use a DC power supply with reinforced insulation on its primary and secondary sides. Failure to do so may result in electric shock.
- When an abnormal condition has occurred, immediately stop operation to turn off the main power supply and control power supply. Failure to do so may result in fire, electrical shock, or injury.

5 Precautions for use

This chapter explains restrictions and requirements the user should consider when using the product.

- **Always use Oriental Motor cables to connect a motor and a driver.**

Refer to the cable models on p.31.

- **When conducting the insulation resistance measurement or the dielectric strength test, be sure to separate the connection between the motor and the driver.**

Conducting the insulation resistance measurement or the dielectric strength test with the motor and driver connected may result in damage to the product.

- **Note when connecting a main power supply and a control power supply in a state of grounding the positive side**

The USB connector on the driver is not electrically insulated. When grounding the positive terminals of a main power supply and a control power supply, do not connect any equipment (PC, etc.) whose negative terminal is grounded. Doing so may cause the driver and this equipment to short, damaging both. When connecting, do not ground equipment.

- **Saving data to the non-volatile memory**

Do not turn off the control power supply while writing the data to the non-volatile memory, and also do not turn off for five seconds after the completion of writing the data. Doing so may abort writing the data and cause an alarm of EEPROM error to generate. The non-volatile memory can be rewritten approximately 100,000 times.

- **Noise elimination measures**

Refer to p.28 for noise elimination measures.

- **Regeneration**

When operating a large load inertia at a high speed, the regenerative energy generated may increase the voltage of the main power supply, causing an alarm of Overvoltage to generate. To prevent damage to the driver, reconsider the operating conditions so that regenerative voltage does not generate.

- **Static electricity measures for the driver**

The driver uses components that are sensitive to static electricity. Take measures against static electricity since static electricity may cause the driver to malfunction or suffer damage.

■ Notes when the connection cable is used

Note the following points when an Oriental Motor cable is used.

- **When inserting the connector**

Hold the connector main body, and insert it in straight securely. Inserting the connector in an inclined state may result in damage to terminals or a connection failure.

- **When pulling out the connector**

Pull out the connector in straight while releasing the lock part of the connector. Pulling out the connector with holding the cable may result in damage to the connector.

- **Bending radius of cable**

- Use the cable in a condition where the bending radius of the cable is as follows.
 - Cable type: More than 6 times the cable diameter
 - Connector type: More than 2.8 times the cable diameter
- Do not bend the lead wires part or secure with a clamp, etc. Doing so may result in damage to the connector.

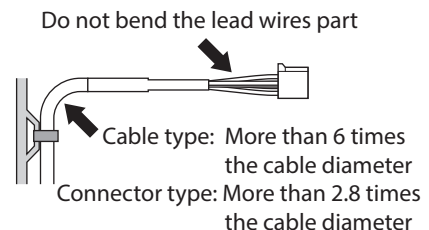

● **How to fix the cable**

Fix the cable at two places near the connectors as shown in the figure or fix it with a wide clamp to take measures to prevent stress from being applied to the connectors.

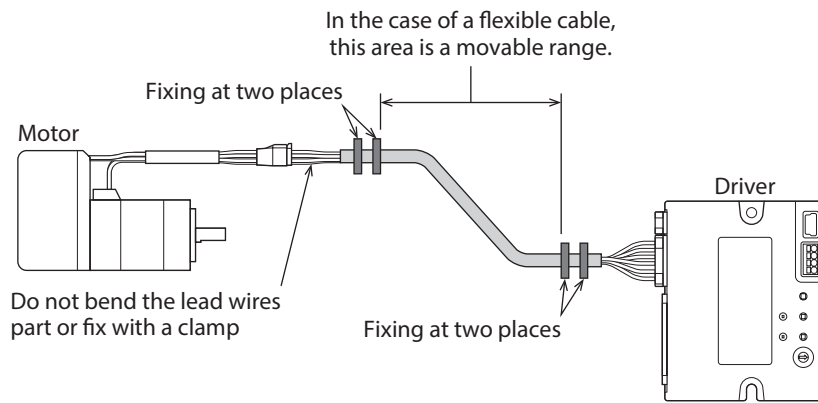

2 Hardware

This part explains names and functions of each part of the driver, installation and connection methods, and so on.

◆Table of contents

1	System configuration.....	16		
2	Preparation.....	17		
2-1	Checking the product.....	17		
2-2	How to identify the product model.....	17		
2-3	Products possible to combine.....	17		
2-4	Information about nameplate.....	18		
2-5	Names and functions of parts.....	18		
2-6	Indication of LEDs.....	19		
3	Installation.....	21		
3-1	Installation location.....	21		
3-2	Installation method.....	21		
4	Connection.....	23		
4-1	Connection example.....	23		
4-2	Connecting the main power supply and the control power supply (CN1).....	24		
4-3	Connecting the PROFINET cable (CN3/CN4).....	26		
4-4	Connecting the USB cable.....	26		
4-5	Connecting input signals (CN5).....	26		
4-6	Noise elimination measures.....	28		
4-7	Compliance with the EMC Directive/Regulations.....	28		
5	Inspection and maintenance.....	30		
5-1	Inspection.....	30		
5-2	Warranty.....	30		
5-3	Disposal.....	30		
6	Cables.....	31		
6-1	Connection cables (For cable type).....	31		
6-2	Connection cables (For connector type).....	34		
6-3	Power supply cable.....	35		

1 System configuration

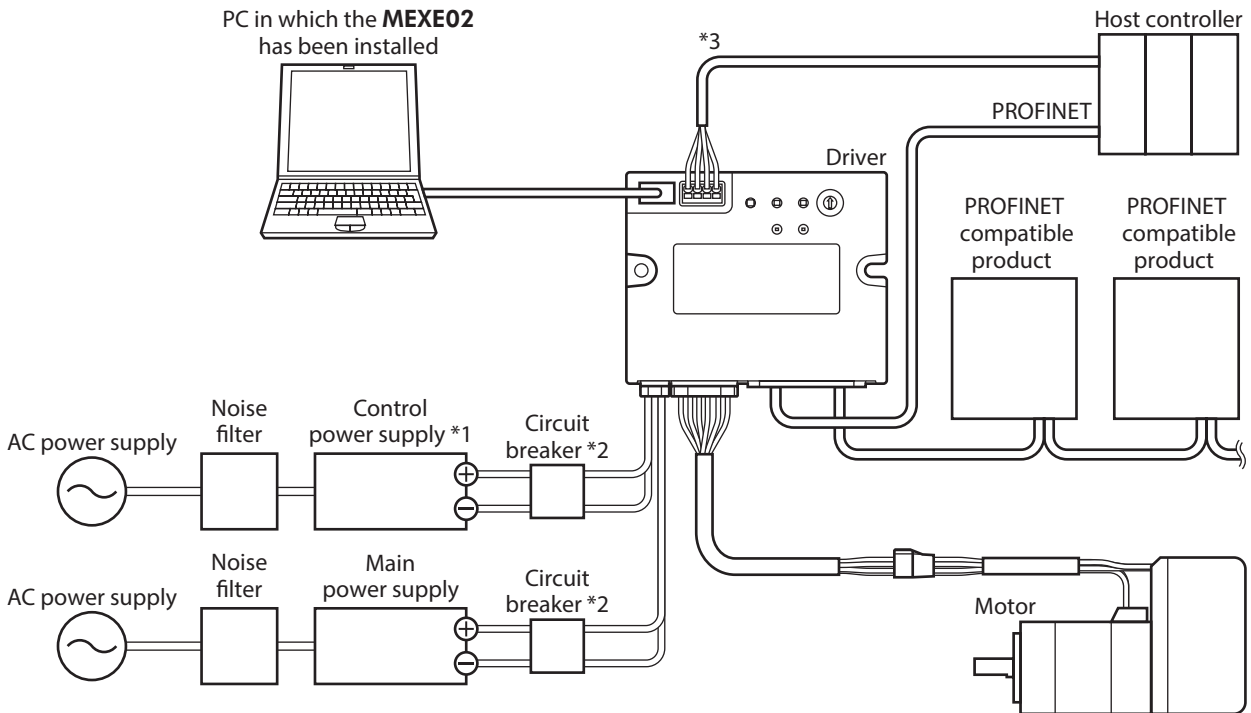

- *1 Connecting the control power supply allows you to continue monitoring even if the main power supply is shut off. Connect it as necessary.
- *2 It is recommended that a circuit breaker or a circuit protector is connected because incorrect wiring of the power supply may cause the internal input circuit to short-circuit.
- *3 Connect when using direct inputs or sensors.

2 Preparation

This chapter explains the items you should check, as well as names and functions of each part.

2-1 Checking the product

Verify that the items listed below are included. Report any missing or damaged items to the Oriental Motor sales office from which you purchased the product.

- Driver 1 unit
- Instructions and Precautions for Safe Use 1 copy

2-2 How to identify the product model

Check the driver model against the model shown on the nameplate. Refer to "2-4 Information about nameplate" on p.18 for how to identify the nameplate.

AZD - K R PN
 1 2 3 4

1	Series	AZD: AZ Series driver
2	Power supply input	K: DC power input
3	Driver figure	R: Compact
4	Type	PN: PROFINET

2-3 Products possible to combine

Products with which the driver can be combined are listed below. Check the model name of the product with the nameplate.

Power supply type	Product type	Applicable Series	Model name representing Series name *1	Example of model name
DC power input	Stepping motor	AZ Series	AZM	AZM46AK
	Motorized actuator	EAC Series *2	EACM	EACM2E05AZAK
		EAS Series *2	EASM	EASM4NXD005AZAK
		EZS Series *2	EZSM	EZSM6D005AZAK
		DR Series	DR	DR28G2.5B03-AZAKU
		DRS2 Series	DRSM	DRSM60-05A4AZAK
		DGII Series *2	DGM DGB DGR	DGM85R-AZAK DGB85R12-AZAKR DGR85R36-AZAKHR
		EH Series *2	EH	EH4-AZAKH
	L Series *2	LM	LM4F150AZAK-1	

*1 The driver described in this manual can be combined with products that begin with these model names.

*2 For these motorized actuators, the equipped motors have been evaluated to affix the CE Marking. The model name of the equipped motor can be checked as follows.

EAC Series, **EAS** Series, **EZS** Series: Check with the motor nameplate.

DGII Series, **EH** Series, **L** Series: Check with "P/N (Motor P/N)" described on the actuator nameplate.

2-4 Information about nameplate

The figure shows an example.

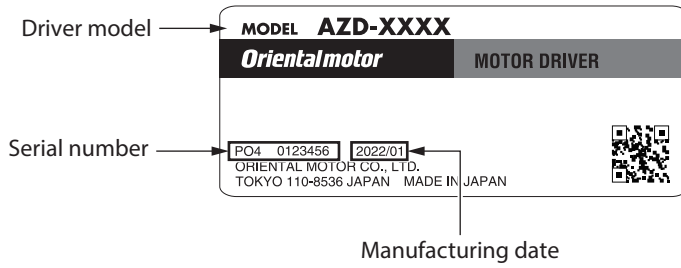

2-5 Names and functions of parts

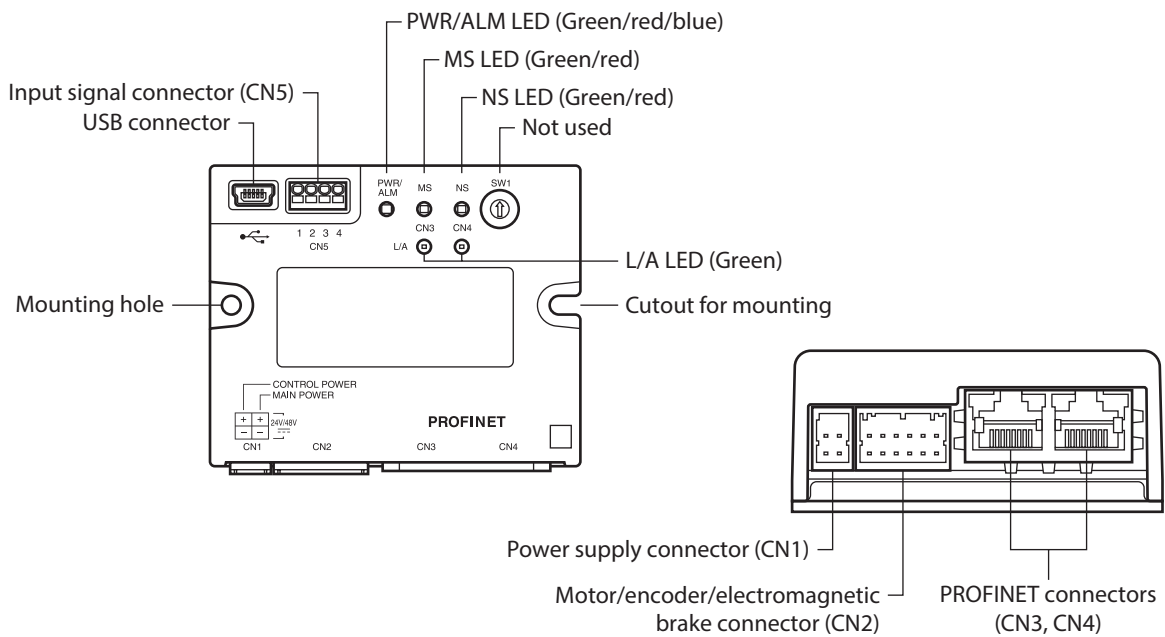

Type	Name	Sign	Description
LED	PWR/ALM LED (Green/Red/Blue)	PWR/ALM	This LED indicates the status of the driver.
	MS LED (Green/Red)	MS	These LEDs indicate the communication status of PROFINET.
	NS LED (Green/Red)	NS	
	L/A LED (Green)	L/A	This LED indicates the LINK/ACT status of PROFINET.
Connector	Power supply connector (CN1)	+, -	Connects a main power supply and a control power supply.
	Motor/encoder/electromagnetic brake connector (CN2)	-	Connects the motor, the encoder, and the electromagnetic brake.
	USB connector		Connects a PC in which the MEXE02 software has been installed. (USB2.0 mini-B port)
	PROFINET connectors (CN3, CN4)	-	Connects the PROFINET cable.
	Input signal connector (CN5)	-	Connects when using direct inputs or sensors.

2-6 Indication of LEDs

■ PWR/ALM LED indication

This LED indicates the status of the driver.

LED status	Description
No light	The main power supply and the control power supply are not turned on.
Green light	The main power supply and/or the control power supply are turned on.
Blinking red	An alarm is being generated. The alarm message generated can be checked by counting the number of times the LED blinks. The LED is lit in green when the alarm is reset.
Blinking blue	<ul style="list-style-type: none"> Information is being generated. The LED is lit in green when the information is cleared. Remote operation is being executed with the MEXE02 software. The LED is lit in green when remote operation is completed.
Repeating "Green → Red → Simultaneously lit * → No light"	This is the driver simulation mode.

* Green and red colors may overlap and it may be visible to orange.

■ MS LED, NS LED

These LEDs indicate the communication status of PROFINET.

LED name	LED status		Description
	Green	Red	
MS LED	No light	No light	The main power supply and the control power supply of the driver are not turned on.
	Blinking	No light	<ul style="list-style-type: none"> The communication settings of PROFINET have not been made in the driver. Make the communication settings using the Configuration tool of the host controller. Blinking the LED was requested by the Configuration tool of the host controller. (When it is blinking simultaneously with the NS LED)
	Light	No light	The driver operates properly.
	No light	Blinking	The data for the communication settings of PROFINET stored in the driver was damaged. Execute either of the following, and turn off the main power supply and the control power supply and on again. After that, make the communication settings again using the Configuration tool of the host controller. <ul style="list-style-type: none"> Initialize the communication settings using the Configuration tool of the host controller. (Only the communication settings can be initialized.) Execute [Restore to factory settings (including communication settings)] under the [Communication] menu with the MEXE02 software. (All parameters including the communication settings are initialized.)
	No light	Light	An error inside the driver was detected. Turn on the main power supply and the control power supply again.
NS LED	No light	No light	<ul style="list-style-type: none"> The main power supply and the control power supply are not turned on. PROFINET communication is not being made.
	Blinking	No light	<ul style="list-style-type: none"> The communication settings of PROFINET are being made. Blinking the LED was requested by the Configuration tool of the host controller. (When it is blinking simultaneously with the MS LED)
	Light	No light	PROFINET communication is being made.
	No light	Blinking	The communication timeout was detected during PROFINET communication. Check the following. <ul style="list-style-type: none"> Is the PROFINET cable disconnected? Is the power supply for the host controller turned on?

■ L/A LED

This LED indicates the LINK/ACT status of PROFINET.

LED status	Description
No light	<ul style="list-style-type: none">• This is in an offline state.• The frame of PROFINET is not sent and received.
Blinking	<ul style="list-style-type: none">• This is in an online state.• The frame of PROFINET is sent and received.
Light	<ul style="list-style-type: none">• This is in an online state.• The frame of PROFINET is not sent and received.

3 Installation

This chapter explains the installation location and installation method of the driver.

3-1 Installation location

The driver is designed and manufactured to be incorporated in equipment. Install it in a well-ventilated location that provides easy access for inspection. The location must also satisfy the following conditions:

- Inside an enclosure that is installed indoors (provide vent holes)
- Operating ambient temperature: 0 to +50 °C (+32 to 122 °F) (non-freezing)
- Operating ambient humidity: 85 % or less (non-condensing)
- Area free of explosive atmosphere, toxic gas (such as sulfuric gas), or liquid
- Area not exposed to direct sun
- Area free of excessive amount of dust, iron particles or the like
- Area not subject to splashing water (rain, water droplets), oil (oil droplets) or other liquids
- Area free of excessive salt
- Area not subject to continuous vibration or excessive shocks
- Area free of excessive electromagnetic noise (from welders, power machinery, etc.)
- Area free of radioactive materials, magnetic fields, or vacuum
- Up to 1,000 m (3,300 ft.) above sea level

3-2 Installation method

The driver can be installed in any direction.

Install the driver onto a flat metal plate offering high heat conductivity (material: aluminum, 150×150×2 mm (5.91×5.91×0.08 in.) or equivalent).

When installing the driver, use the mounting holes and the cutouts for mounting to secure on the metal plate with two screws (M3: not included).

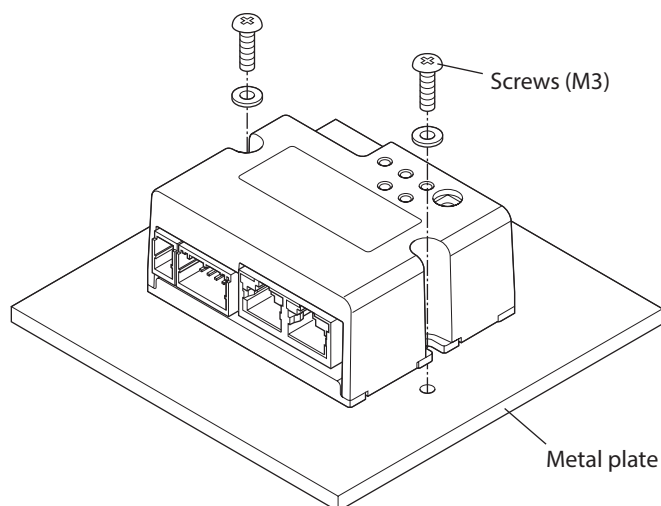

Note

- Install the driver in an enclosure.
- Do not install any equipment that generates a large amount of heat or noise near the driver.
- Do not install the driver underneath a host controller or other equipment sensitive to heat.
- If the ambient temperature of the driver exceeds 50 °C (122 °F), reconsider the ventilation conditions such as providing forced cooling by using fans.

■ **Dimensions [Unit: mm (in.)]**

Mass: 0.11 kg (0.24 lb.)

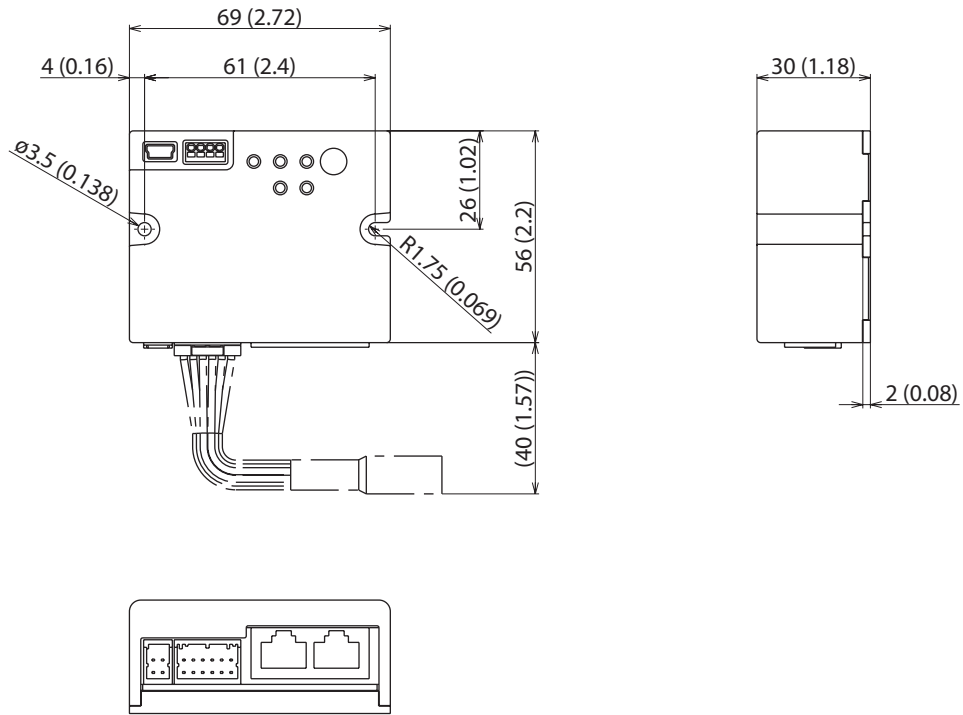

4 Connection

This chapter explains a connection example of a driver and a motor, connection methods of a main power supply and a control power supply, and so on.

It also explains installation and wiring methods to conform to the EMC Directive/Regulations as well as measures against electrical noise.

4-1 Connection example

The figure shows an example when the **AZM14** motor is connected.

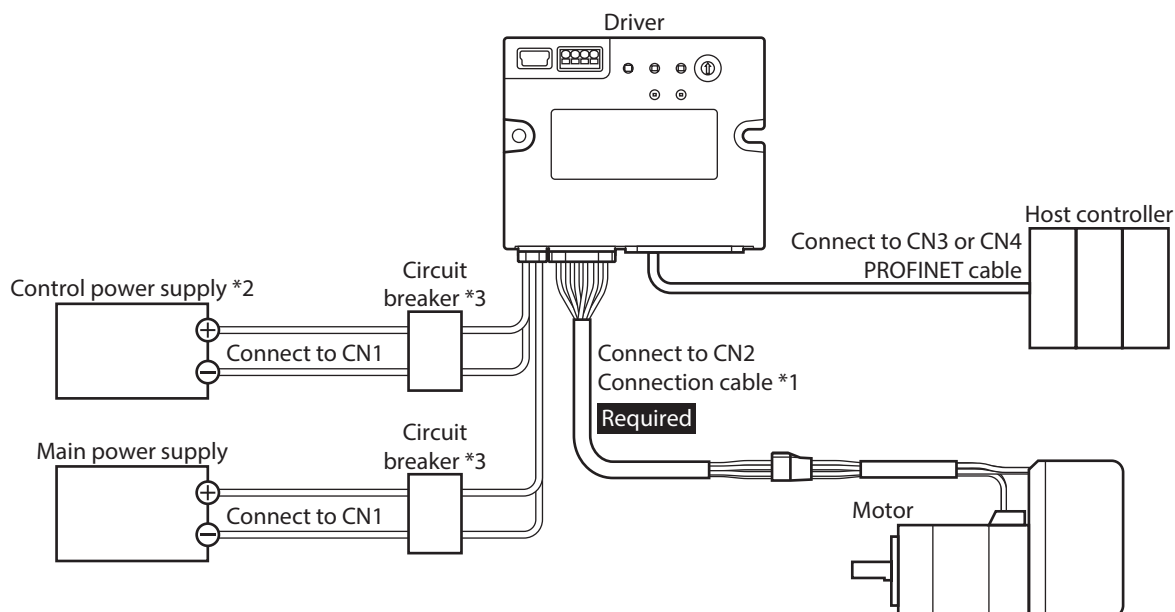

*1 It is an Oriental motor cable. Purchase is required separately.

*2 Connecting the control power supply allows you to continue monitoring even if the main power supply is shut off. Connect it as necessary.

*3 It is recommended that a circuit breaker or a circuit protector is connected because incorrect wiring may cause the internal input circuit to short-circuit.

- Note**
- Connect the connectors securely. Insecure connections may cause malfunction or damage to the motor or the driver.
 - When connecting the cables, secure them so that no load is applied to the connectors. Applying a load to the connector may result in a connection failure, causing the driver to malfunction.
 - Keep 10 m (32.8 ft.) or less for the wiring distance between a motor and a driver. Exceeding 10 m (32.8 ft.) in the wiring distance may result in increase of the electrical noise emitted from the driver.
 - Keep 2 m (6.6 ft.) or less for the cable length of the main power supply and control power supply cables.

- memo**
- Before connecting or disconnecting a connector, turn off the main power supply and the control power supply, and check the PWR/ALM LED has been turned off.
 - When disconnecting the connector, pull out while pressing the latches on the connector with fingers.

4-2 Connecting the main power supply and the control power supply (CN1)

Connect a main power supply to the CN1 connector.
 Connecting the control power supply allows you to continue monitoring even if the main power supply is shut off.
 Connect it as necessary.

Note Make sure the polarity of the power supply before connecting. Reverse-polarity connection may cause damage to the driver.

■ Applicable connector

Type	Part number	Applicable lead wire
Connector housing	1-1827864-2 (TE Connectivity)	<ul style="list-style-type: none"> Conductor size: AWG22 (0.34 to 0.37 mm²) AWG20 (0.51 to 0.53 mm²) AWG18 (0.85 to 0.87 mm²) Lead wire insulation outer diameter: ø1.4 to 2.2 mm (ø0.055 to 0.087 in.) Lead wire insulation strip length: 1.7 to 2.3 mm (0.067 to 0.091 in.)
Contact	1827589-2 (TE Connectivity)	
Designated crimp tool	2119142-1 (TE Connectivity)	

■ Pin assignment

The figure shows the view from the insertion side of lead wire.
 Insert the lead wires with crimped contacts in the direction of the arrow.

Pin No.	Name	Description
B1	Control power supply	+24 VDC / +48 VDC
A1	GND	Ground for control power supply

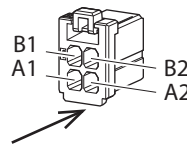

Pin No.	Name	Description
B2	Main power supply	+24 VDC / +48 VDC
A2	GND	Ground for main power supply

memo A1 and A2 are not electrically insulated.

■ Voltage specifications

The voltage specifications of power supply input include the rated voltage and the allowable operating voltage.
 The voltage specifications are common for the main power supply and the control power supply.

Rated voltage	24 VDC±5 % 48 VDC±5 %
Allowable operating voltage	24 VDC input: 20 to 32 VDC (22.8 to 32 VDC) * 48 VDC input: 40 to 55 VDC

* The value in parentheses () is the one when the electromagnetic brake motor is connected.

memo Set the "Main power mode" parameter to "0: 24 VDC" or "1: 48 VDC" when the main power supply starts up slowly or the voltage of the main power supply is unstable. (⇒ p.82)

Internal input circuit

The driver can be used with the main power supply and control power supply, or with the main power supply only. When using only the main power supply, the power is supplied from the main power supply to the control power supply circuit inside the driver.

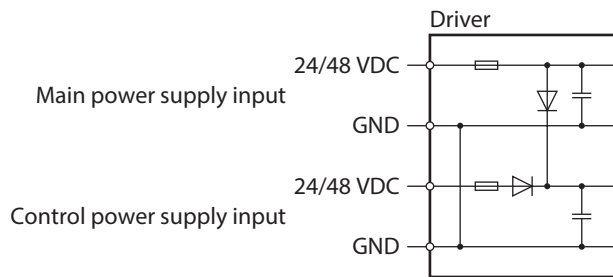

Power supply current capacity

Current capacity for main power supply

The current capacity for the main power supply varies depending on the product combined.

Check the current capacity in reference to the equipped motor model when using the **EAC** Series, **EAS** Series, or **EZS** Series.

The box (□) in the model indicates an alphabet (**B**, **M**, or **R**) representing the shape of the actuator.

Series	Model	Rated voltage	Power supply current capacity
AZ Series EAC Series EAS Series EZS Series	AZM14	24 VDC±5 %	0.4 A or more
	AZM15		0.5 A or more
	AZM24, AZM26		1.4 A or more
	AZM46	24 VDC±5 % 48 VDC±5 %	1.6 A or more
	AZM48		2.1 A or more
	AZM66		3.7 A or more
	AZM69		3.5 A or more
DGII Series	DG□60	24 VDC±5 %	1.4 A or more
	DG□85	24 VDC±5 %	1.6 A or more
	DG□130	48 VDC±5 %	3.7 A or more
DR Series	DR20	24 VDC±5 %	0.4 A or more
	DR28		1.3 A or more
DRS2 Series	DRSM42	24 VDC±5 %	1.5 A or more
	DRSM60	48 VDC±5 %	2.6 A or more
EH Series	EH3	24 VDC±5 %	0.4 A or more
	EH4		1.4 A or more
L Series	LM2, LM4	24 VDC±5 % 48 VDC±5 %	3.7 A or more

Current capacity for control power supply

Rated voltage	Power supply current capacity	
	Without electromagnetic brake	With electromagnetic brake
24 VDC±5 % 48 VDC±5 %	0.15 A	0.4 A*

* The **AZM46** type is 0.23 A.

4-3 Connecting the PROFINET cable (CN3/CN4)

Connect the PROFINET cable to the PROFINET connector (CN3, CN4).

■ Pin assignment

Signal name	Description
TXP	Transmitted data +
TXN	Transmitted data -
RXP	Received data +
N.C.	-
N.C.	-
RXN	Received data -
N.C.	-
N.C.	-

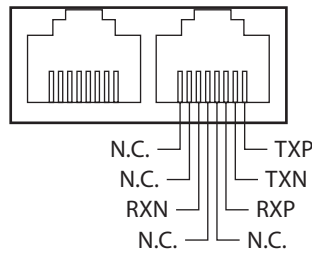

4-4 Connecting the USB cable

Using a USB cable of the following specifications, connect a PC in which the **MEXE02** software has been installed to the USB connector.

Specifications	USB2.0 (Full speed)
Cable	Length: 3 m (9.8 ft.) or less Shape: A to mini B



- Connect the driver and a PC directly using a USB cable.
- In large electrically noisy environments, use the USB cable with a ferrite core or install a ferrite core to the USB cable.

4-5 Connecting input signals (CN5)

Connect when using direct inputs or sensors.

■ Applicable lead wire and terminal

Applicable lead wire	<ul style="list-style-type: none"> • Conductor size: AWG26 to 20 (0.14 to 0.5 mm²) • Lead wire strip length: 6 mm (0.24 in.)
Applicable ferrule terminal	Without sleeve: 0.25 to 0.5 mm ² With sleeve: 0.25 to 0.34 mm ²

■ Pin assignment

Pin No.	Signal name	Description*
1	IN0+	Control input 0 (STOP)
2	IN0-	
3	IN1+	Control input 1 (FREE)
4	IN1-	

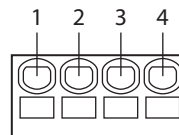

* (): Initial value

■ Connection example with a current sink output circuit

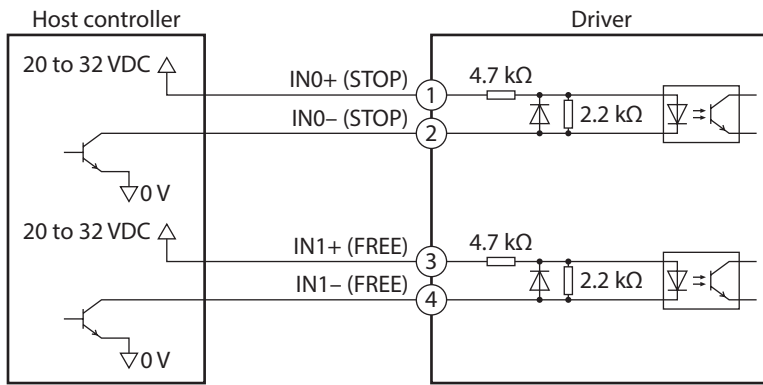

* (): Initial value

■ Connection example with a current source output circuit

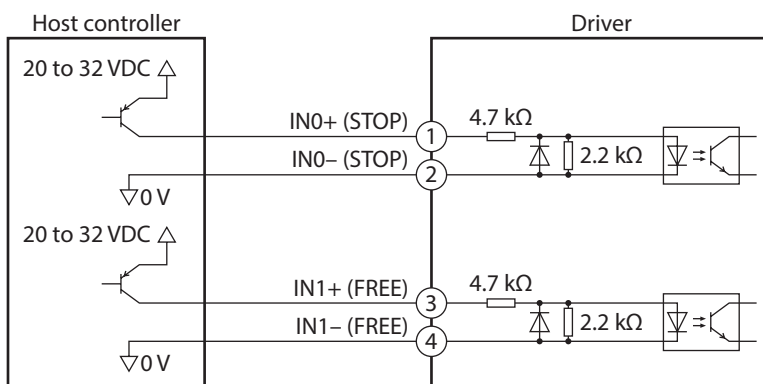

* (): Initial value

4-6 Noise elimination measures

There are two types of electrical noise: One is noise that enters the driver from the outside and causes it to malfunction, and the other is noise that is emitted from the driver and causes peripheral equipment to malfunction. For noise entering the driver from the outside, take measures to prevent the driver from malfunctioning. It is necessary to take appropriate measures because the signal lines are very likely to be affected by the noise. For the noise that is emitted by the driver, take measures to suppress it.

■ Measures to eliminate electrical noise

- Install the driver inside a metal enclosure.
- Use a DC power supply that complies with the EMC Directive/Regulations.
- When relays or electromagnetic switches are used, use noise filters or CR circuits to suppress the surge generated by these devices.
- Keep the cables as short as possible.
- Use shielded twisted pair cables for power lines and signal lines.
- Keep power lines, such as motor and power supply cables, at least 200 mm (7.87 in.) away from signal lines. Also, do not bundle the cables or wire them in parallel. If the power cables and signal cables must cross, cross them at right angles.
- Wrap the cable around a ferrite core. This prevents the propagated noise from entering the driver or from being emitted from the driver. To increase the effect of noise attenuation by the ferrite core, wrap the cable several more turns.
- To ground a shielded cable, use a conductive cable clamp that ensures contact with the entire circumference of the shielded cable, and ground it as close to the equipment as possible.
- Use the shortest, thickest grounding wire possible.
- Choose a large and uniformly conductive surface for the grounding point.
- Ground the motor, driver and other peripheral control equipment so that a potential difference does not occur among the grounds.

4-7 Compliance with the EMC Directive/Regulations

Oriental Motor products are compliant with the EMC Directive/Regulations in accordance with the contents of “4-6 Noise elimination measures” under the terms of “Example of installation and wiring” on p.29. The results of EMC testing of the equipment will vary depending on the type, layout, wiring method, etc. of the parts and components used. Verify compliance with the EMC Directive/Regulations in a condition where all parts and components, including Oriental Motor products, are assembled into the equipment.

CAUTION

This equipment is not intended for use in residential environments nor for use on a low-voltage public network supplied in residential premises, and it may not provide adequate protection to radio reception interference in such environments.

● **Example of installation and wiring**

The figure shows an example when the cable type electromagnetic brake motor is used.

When connecting the following products, cover the motor cable with a shielded braided sleeving. Furthermore, EMC tests are performed with a shielded braided sleeving grounded at both ends with cable clamps.

- **AZ Series: AZM14, AZM15, AZM24, AZM26**
- **EAC Series: EACM2**
- **EAS Series: EASM2**
- **DR Series: DR20, DR28**
- **DGII Series: DGM60, DGR60**
- **EH Series: EH3, EH4**

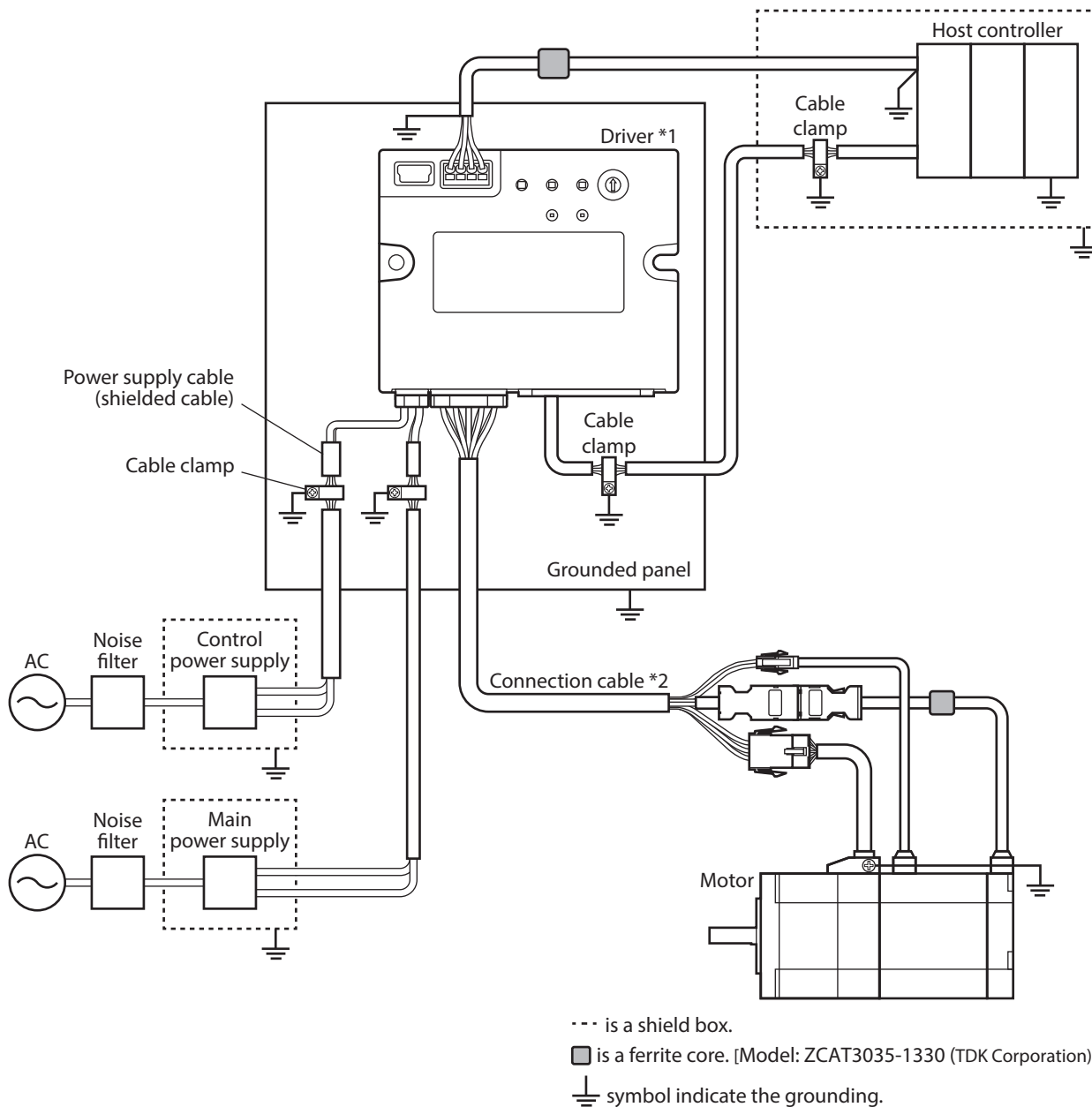

*1 The driver is grounded by making the heat sink contact directly with the grounded panel.

*2 An Oriental Motor cable is used.

5 Inspection and maintenance

5-1 Inspection

It is recommended that periodic inspections are conducted for the items listed below after each operation of the motor. If an abnormality is found, discontinue any use and contact your nearest Oriental Motor sales office.

■ Inspection item

- Check if the openings in the driver are clogged.
- Check if the installation place of the driver is loose.
- Check if any of the connection parts of the driver is loose.
- Check if dust is deposited on the driver.
- Check if the driver has unusual smells or appearance defects.



The driver uses semiconductor components. Static electricity may damage the semiconductor components of the driver, so be extremely careful when handling them.

5-2 Warranty

Check on the Oriental Motor Website for the product warranty.

5-3 Disposal

Dispose the product correctly in accordance with laws and regulations, or instructions of local governments.

6 Cables

6-1 Connection cables (For cable type)

■ Connection cables/Flexible connection cables (For AZM14, AZM15, AZM24, AZM26)

These cables are used when connecting a motor and a driver.

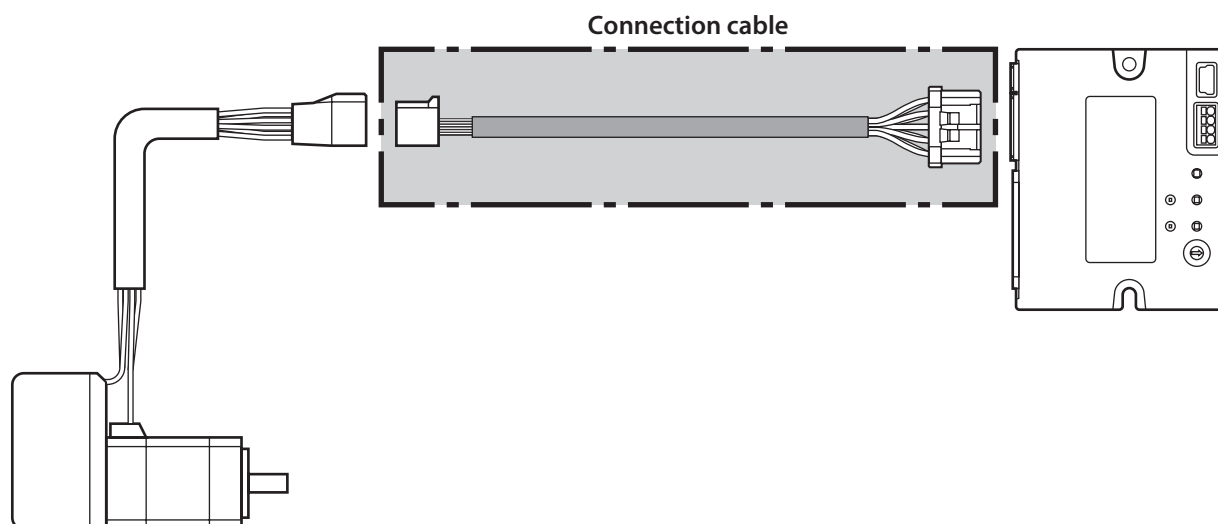

2 Hardware

memo When installing the motor on a moving part, use a flexible cable.

● Connection cables For motor/encoder

Model	Length [m (ft.)]
CCM005Z2AAF	0.5 (1.6)
CCM010Z2AAF	1 (3.3)
CCM030Z2AAF	3 (9.8)
CCM050Z2AAF	5 (16.4)
CCM100Z2AAF	10 (32.8)

● Flexible connection cables For motor/encoder

Model	Length [m (ft.)]
CCM005Z2AAR	0.5 (1.6)
CCM010Z2AAR	1 (3.3)
CCM030Z2AAR	3 (9.8)
CCM050Z2AAR	5 (16.4)
CCM100Z2AAR	10 (32.8)

■ **Connection cables/Flexible connection cables**
(For AZM46, AZM48, AZM66, AZM69)

These cables are used when connecting a motor and a driver.
 The figure shows an example when the electromagnetic brake motor is used.

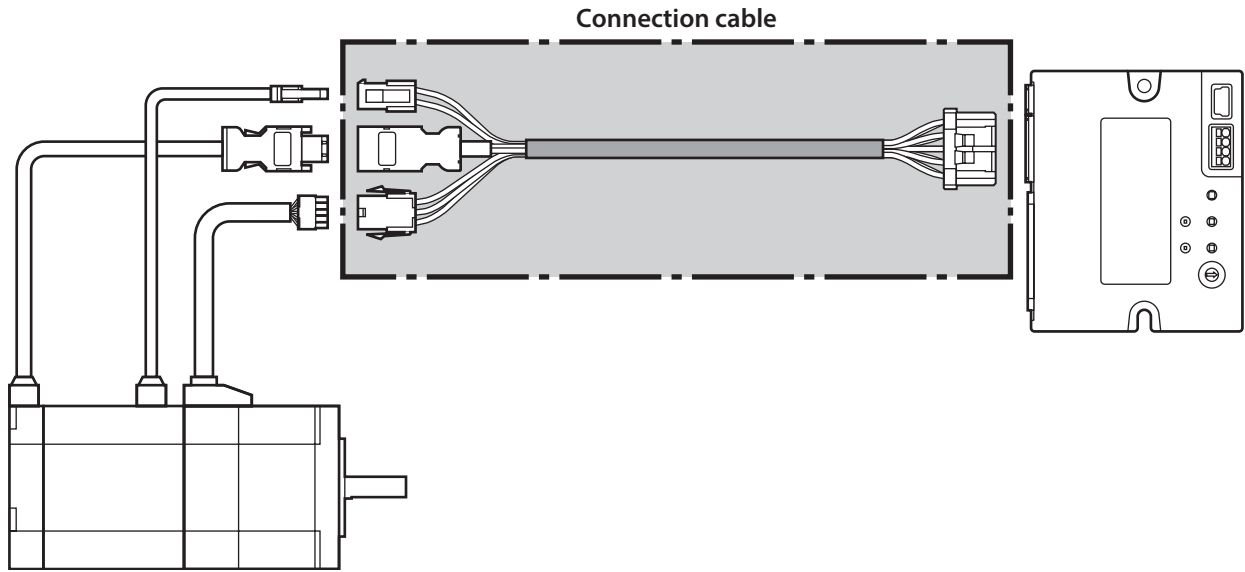

memo When installing the motor on a moving part, use a flexible cable.

● **Connection cables**

For motor/encoder

Model	Length [m (ft.)]
CCM005Z2ABF	0.5 (1.6)
CCM010Z2ABF	1 (3.3)
CCM030Z2ABF	3 (9.8)
CCM050Z2ABF	5 (16.4)
CCM100Z2ABF	10 (32.8)

For motor/encoder/electromagnetic brake

Model	Length [m (ft.)]
CCM005Z2ACF	0.5 (1.6)
CCM010Z2ACF	1 (3.3)
CCM030Z2ACF	3 (9.8)
CCM050Z2ACF	5 (16.4)
CCM100Z2ACF	10 (32.8)

● **Flexible connection cables**

For motor/encoder

Model	Length [m (ft.)]
CCM005Z2ABR	0.5 (1.6)
CCM010Z2ABR	1 (3.3)
CCM030Z2ABR	3 (9.8)
CCM050Z2ABR	5 (16.4)
CCM100Z2ABR	10 (32.8)

For motor/encoder/electromagnetic brake

Model	Length [m (ft.)]
CCM005Z2ACR	0.5 (1.6)
CCM010Z2ACR	1 (3.3)
CCM030Z2ACR	3 (9.8)
CCM050Z2ACR	5 (16.4)
CCM100Z2ACR	10 (32.8)

■ Extension cables/Flexible extension cables

These cables are used when extending a connection cable (add between the driver and connection cable). Use if the length of the connection cable used is not enough when extending the distance between a motor and a driver.

The extension cables and the flexible extension cables are common to all motors.

The figure shows an example when the **AZM14** motor is connected.

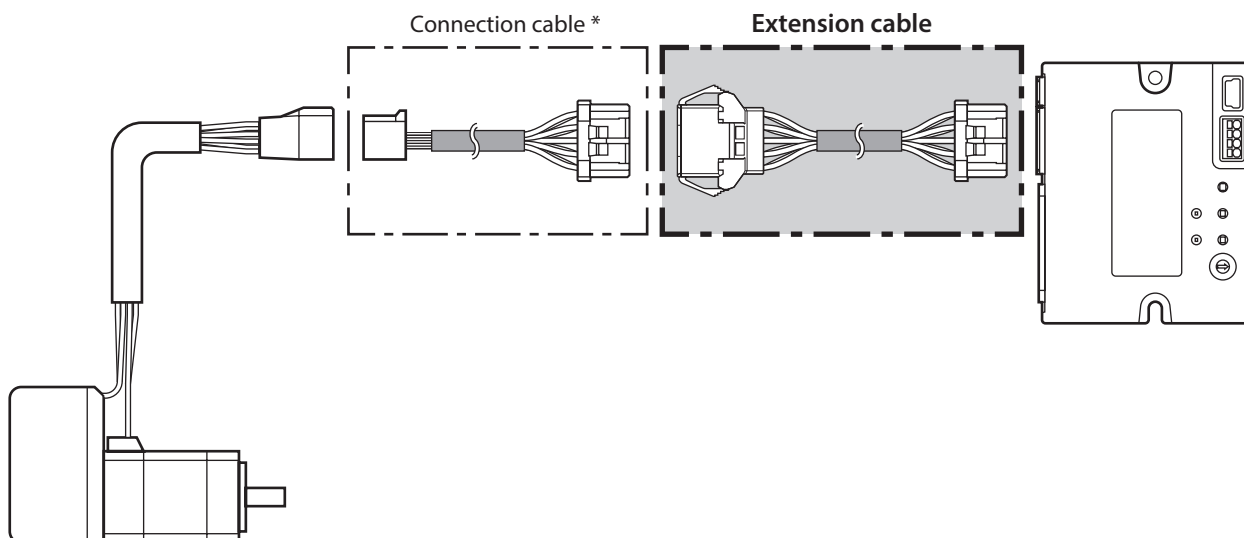

* Use the connection cable used.



- When installing the motor on a moving part, use a flexible cable.
- When extending the wiring length by connecting an extension cable to the connection cable, make the total cable length 10 m (32.8 ft.) or less.

● Extension cables

Model	Length [m (ft.)]
CCM010Z2ADFT	1 (3.3)
CCM030Z2ADFT	3 (9.8)
CCM050Z2ADFT	5 (16.4)

● Flexible extension cables

Model	Length [m (ft.)]
CCM010Z2ADRT	1 (3.3)
CCM030Z2ADRT	3 (9.8)
CCM050Z2ADRT	5 (16.4)

6-2 Connection cables (For connector type)

■ Connection cables/Flexible connection cables

These cables are used when connecting a motor and a driver.

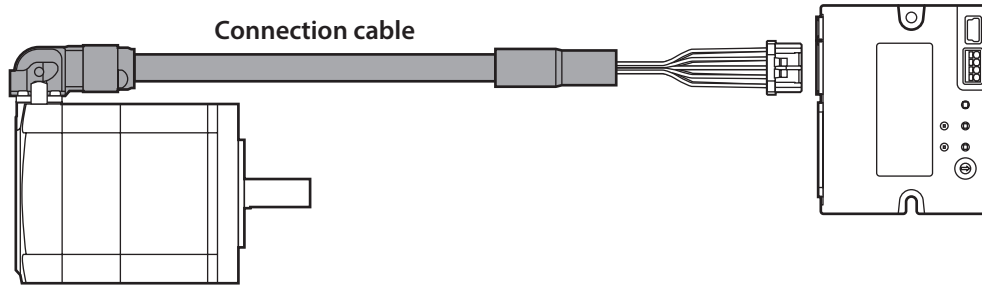

The model name of the connection cable varies depending on the outlet direction from the motor. Refer to the figures below.

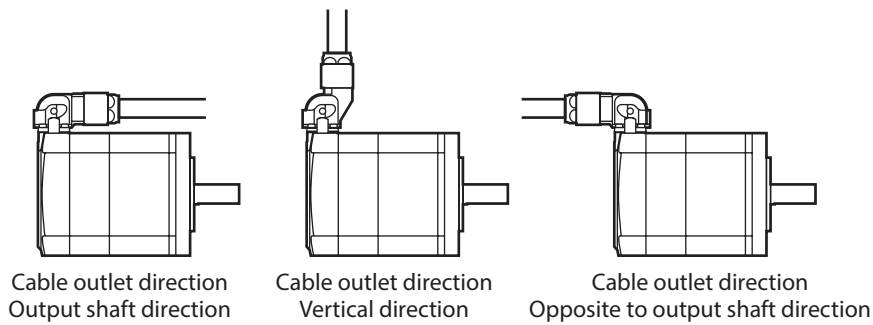

memo When installing the motor on a moving part, use a flexible cable.

● Connection cables

Length [m (ft.)]	Cable outlet direction		
	Output shaft direction	Vertical direction	Opposite to output shaft direction
0.2 (0.7)	CCM002Z1EFF	CCM002Z1EVF	CCM002Z1EBF
0.5 (1.6)	CCM005Z1EFF	CCM005Z1EVF	CCM005Z1EBF
1 (3.3)	CCM010Z1EFF	CCM010Z1EVF	CCM010Z1EBF
2 (6.6)	CCM020Z1EFF	CCM020Z1EVF	CCM020Z1EBF
3 (9.8)	CCM030Z1EFF	CCM030Z1EVF	CCM030Z1EBF
5 (16.4)	CCM050Z1EFF	CCM050Z1EVF	CCM050Z1EBF
7 (23.0)	CCM070Z1EFF	CCM070Z1EVF	CCM070Z1EBF
10 (32.8)	CCM100Z1EFF	CCM100Z1EVF	CCM100Z1EBF

● Flexible connection cables

Length [m (ft.)]	Cable outlet direction		
	Output shaft direction	Vertical direction	Opposite to output shaft direction
0.5 (1.6)	CCM005Z1EFR	CCM005Z1EVR	CCM005Z1EBR
1 (3.3)	CCM010Z1EFR	CCM010Z1EVR	CCM010Z1EBR
2 (6.6)	CCM020Z1EFR	CCM020Z1EVR	CCM020Z1EBR
3 (9.8)	CCM030Z1EFR	CCM030Z1EVR	CCM030Z1EBR
5 (16.4)	CCM050Z1EFR	CCM050Z1EVR	CCM050Z1EBR
7 (23.0)	CCM070Z1EFR	CCM070Z1EVR	CCM070Z1EBR
10 (32.8)	CCM100Z1EFR	CCM100Z1EVR	CCM100Z1EBR

■ Extension cables/Flexible extension cables

These cables are used when extending a connection cable (add between the driver and connection cable). Use if the length of the connection cable used is not enough when extending the distance between a motor and a driver.

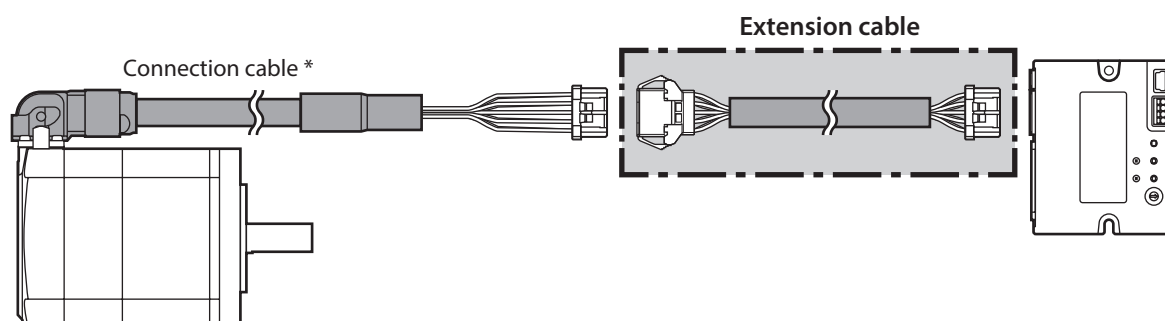

* Use the connection cable used.



- When installing the motor on a moving part, use a flexible cable.
- When extending the wiring length by connecting an extension cable to the connection cable, make the total cable length 10 m (32.8 ft.) or less.

● Extension cables

Model	Length [m (ft.)]
CCM010Z2ADFT	1 (3.3)
CCM030Z2ADFT	3 (9.8)
CCM050Z2ADFT	5 (16.4)

● Flexible extension cables

Model	Length [m (ft.)]
CCM010Z2ADRT	1 (3.3)
CCM030Z2ADRT	3 (9.8)
CCM050Z2ADRT	5 (16.4)

6-3 Power supply cable

This cable is used when connecting a driver to power supplies.

Model: **LCD06Z2AY** [0.6 m (2 ft.)]

3 PROFINET communication

This part explains how to control via PROFINET.

◆ Table of contents

1	Flow of setting of PROFINET communication.....	38
2	Guidance	39
3	Communication specifications	41
4	IO data	42
	4-1 IO data format.....	42
	4-2 Input data.....	43
	4-3 Output data	48
	4-4 Processing order of IO data.....	52
	4-5 Data writing.....	53
	4-6 Data reading.....	54
5	Example of execution for operation	56
	5-1 Positioning operation	56
	5-2 Continuous operation.....	57
6	Direct data operation	58
	6-1 Overview of direct data operation	58
	6-2 Output data and parameters required for direct data operation.....	59
	6-3 Operation example.....	62



1 Flow of setting of PROFINET communication

The contents of are explained in this manual.

Refer to the **AZ Series OPERATING MANUAL Function Edition** for the contents of .

 is the title name described in the reference destination.

memo The title number described in the reference destination may be changed. Use the title name when checking the reference destination.

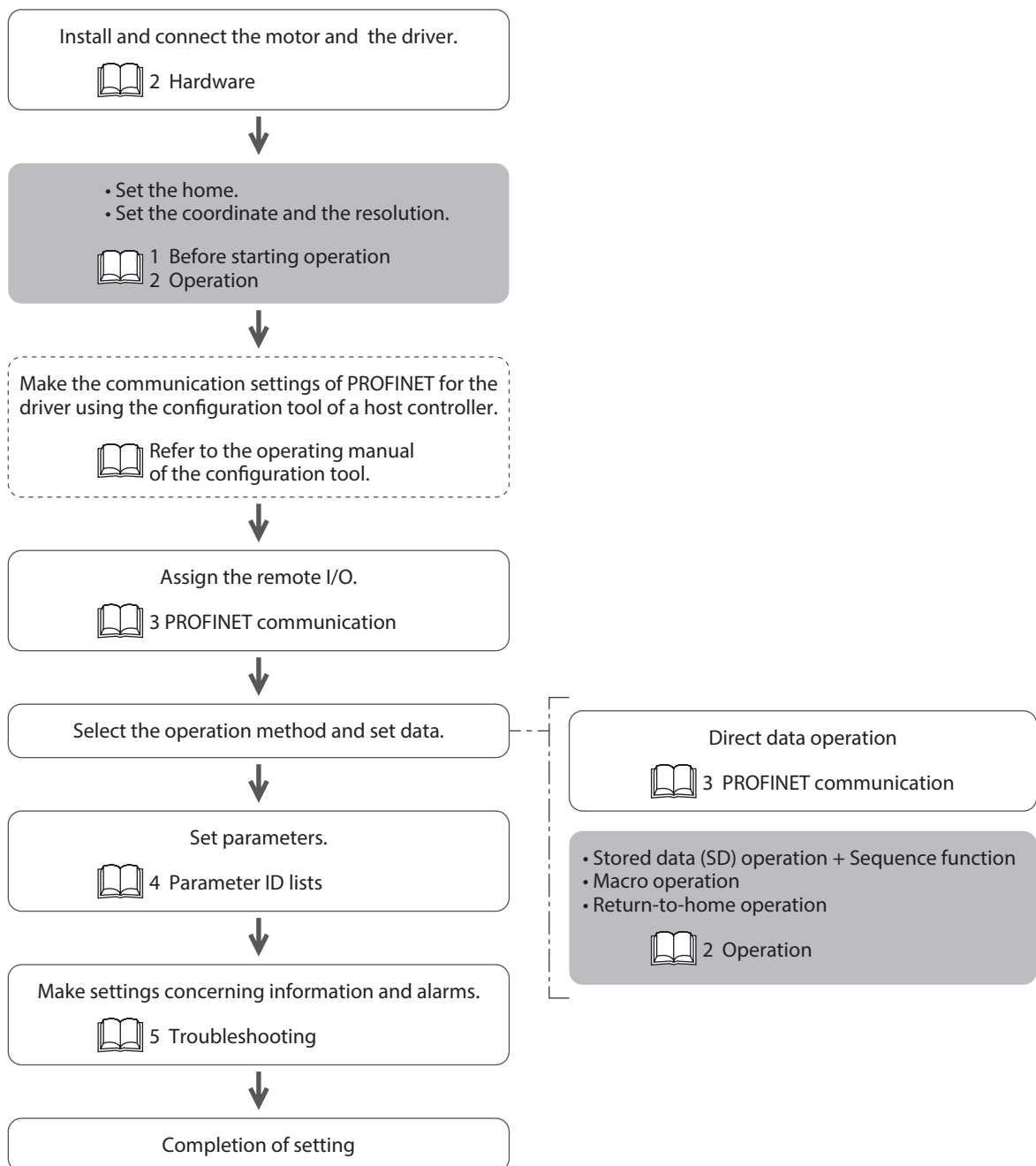

2 Guidance

If you are new to this product, read this section to understand the operation flow.
This is an example how to set operation data and start the motor using the host controller.

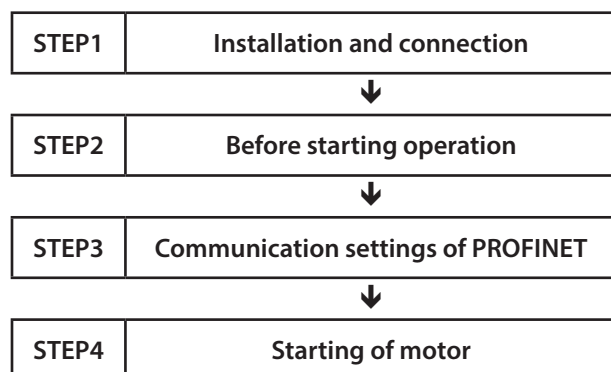

Note

- Before operating the motor, check the surrounding conditions to ensure safety.
- Before starting based on the guidance, import the GSD file to the setting tool of the host controller and register the system configuration in advance. For details, contact your nearest Oriental Motor sales office.

STEP 1 Check the installation and the connection.

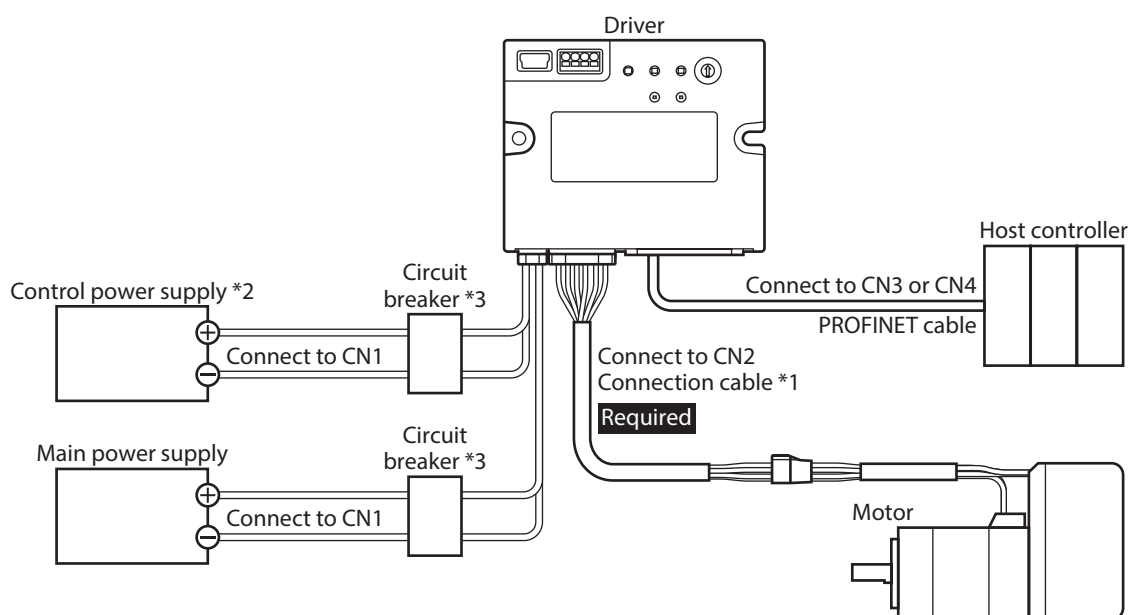

*1 It is an Oriental motor cable. Purchase is required separately.

*2 Connecting the control power supply allows you to continue monitoring even if the main power supply is shut off. Connect it as necessary.

*3 It is recommended that a circuit breaker or a circuit protector is connected because incorrect wiring may cause the internal input circuit to short-circuit.

STEP 2 Make preparations for operation.

Refer to "Before starting operation" in the **AZ** Series OPERATING MANUAL Function Edition.

STEP 3 Make communication settings of PROFINET for the driver.

Communication settings of PROFINET are made using the Configuration tool of a host controller.
Make the communication settings such as device names and IP addresses using the Configuration tool.
Refer to the operating manual of the Configuration tool for how to set.

STEP 4 The host controller starts the motor

As an example, this section explains how to execute the following positioning operation.

● Setting example

- Operation data number: 1
- Position: 5,000 steps
- Other settings: Initial values

● Operation processing flow

Descriptions are given using the host controller as the subject.

1. Set the following operation data to turn the WR-REQ ON.
The operation data is set in the driver. When the setting is completed, the WR-END is turned ON.

Byte	Description	Setting value	Note
34, 35	Write parameter ID	3105	Parameter ID of "Position" of operation data No. 1
36 to 39	Write data	5,000	Position: 5,000 steps

2. Turn the WR-REQ OFF.
The WR-END is returned to OFF.
3. Check the READY has been turned ON.
4. Select the operation data No. 1 to turn the START ON.
Positioning operation is started.
5. Check the READY has been turned OFF, and turn the START OFF.

STEP 5 Were you able to operate?

How did it go? Were you able to operate the motor properly? If the motor does not operate, check the following points.

- Is the PWR/ALM LED blinking in red?
An alarm is being generated. Refer to p.100 for details.
- Are the main power supply, the control power supply, the motor, and the PROFINET cable connected securely?
- Are the communication settings of PROFINET correct?
- Is the MS LED blinking in green or red? Is the NS LED blinking in red?
A communication error is being detected. Refer to p.98 for details.
- Is the MS LED lit in red?
An error inside the driver is being detected. Turn off the main power supply and the control power supply and on again.
- Is the NS LED blinking in green?
The communication settings of PROFINET are being made. The motor cannot be operated during the communication settings. Operate after the NS LED is lit in green.

3 Communication specifications

Communications standards	PROFINET IO Version 2.4	
Vendor ID	0x33E: ORIENTAL MOTOR	
Transmission rate	100 Mbps (autonegotiation)	
Communication mode	Full duplex (autonegotiation)	
Cable specifications	Shielded twisted pair (STP) cable straight-through/crossover cable, category 5e or higher is recommended	
Communication connector	RJ45x2 (shielded)	
Conformance Class	B	
RT/IRT	RT	
NetLoad Class	I	
Protocol to be supported	DCP, LLDP, SNMP, MRP	
Number of occupied bytes	Output (host controller → driver)	40 bytes
	Input (driver → host controller)	56 bytes
Network topology	Star, Tree, Line, Ring	

4 IO data

4-1 IO data format

This section shows transfer contents of IO data. The order of data is in big-endian format.

Byte	Input (driver → host controller)	Output (host controller → driver)
0, 1	Remote I/O (R-OUT)	Remote I/O (R-IN)
2, 3	Operation data number selection_R	Operation data number selection
4, 5	Fixed I/O (OUT)	Fixed I/O (IN)
6, 7	Present alarm	Direct data operation operation type
8 to 11	Feedback position	Direct data operation position
12 to 15	Feedback speed [Hz]	Direct data operation operating speed
16 to 19	Command position	Direct data operation starting/changing rate
20, 21	Torque monitor	Direct data operation stopping deceleration
22, 23	CST operating current	
24, 25	Information	Direct data operation operating current
26, 27		Direct data operation forwarding destination
28, 29		Reserved
30, 31	Read parameter ID_R	Read parameter ID
32, 33	Read/write status	Write request
34, 35	Write parameter ID_R	Write parameter ID
36 to 39	Read data	Write data
40 to 43	Assignable monitor 0	–
44 to 47	Assignable monitor 1	–
48 to 51	Assignable monitor 2	–
52 to 55	Assignable monitor 3	–

Note All IO data in the format is exchanged periodically between the driver and the host controller. Therefore, check all data when setting. If only some data is set, the data that is not set will be undefined, which may cause the driver to malfunction.

4-2 Input data

Data transferred from the driver to the host controller is called Input data.

■ Input data format

Contents of the Input data are as follows. The order of data is in big-endian format.

Byte	Size (byte)	Description
0, 1	2	Remote I/O (R-OUT)
2, 3	2	Operation data number selection_R
4, 5	2	Fixed I/O (OUT)
6, 7	2	Present alarm
8 to 11	4	Feedback position
12 to 15	4	Feedback speed [Hz]
16 to 19	4	Command position
20, 21	2	Torque monitor
22, 23	2	CST operating current
24 to 27	4	Information
28, 29	2	Reserved
30, 31	2	Read parameter ID_R
32, 33	2	Read/write status
34, 35	2	Write parameter ID_R
36 to 39	4	Read data
40 to 43	4	Assignable monitor 0
44 to 47	4	Assignable monitor 1
48 to 51	4	Assignable monitor 2
52 to 55	4	Assignable monitor 3

● Order of 2 byte data

Example: When the CST operating current is 1,000 (0x03E8h)

Byte	Size (byte)	Description	Value (Hex)
22	2	CST operating current (upper)	0x03
23		CST operating current (lower)	0xE8

● Order of 4 byte data

Example: When the feedback position is 300,000 (0x000493E0h)

Byte	Size (byte)	Description	Value (Hex)
8	4	Feedback position (most significant)	0x00
9		Feedback position (upper)	0x04
10		Feedback position (lower)	0x93
11		Feedback position (least significant)	0xE0

■ Details of Input data

● Remote I/O (R-OUT)

This is the I/O accessed via PROFINET.

The assignments of signals can be changed using the "R-OUT output function" parameters.

Byte	Bit	Name	Description	Initial assignment
1	0	R-OUT0	Output in response to a signal assigned with the "R-OUT output function" parameter.	64: M0_R
	1	R-OUT1		65: M1_R
	2	R-OUT2		66: M2_R
	3	R-OUT3		32: START_R
	4	R-OUT4		144: HOME-END
	5	R-OUT5		132: READY
	6	R-OUT6		135: INFO
	7	R-OUT7		129: ALM-A
0	8	R-OUT8		136: SYS-BSY
	9	R-OUT9		160: AREA0
	10	R-OUT10		161: AREA1
	11	R-OUT11		162: AREA2
	12	R-OUT12		157: TIM
	13	R-OUT13		134: MOVE
	14	R-OUT14		138: IN-POS
	15	R-OUT15	140: TLC	

● Operation data number selection_R

Byte	Bit	Name	Description
3	0	M0_R	Output in response to an input signal.
	1	M1_R	
	2	M2_R	
	3	M3_R	
	4	M4_R	
	5	M5_R	
	6	M6_R	
	7	M7_R	
2	8 to 15	Reserved	0 is returned.

- **Fixed I/O (OUT)**

This is the I/O accessed via PROFINET.

Assignments of signals cannot be changed.

Byte	Bit	Name	Description
5	0	SEQ-BSY	Output while stored data operation is performed.
	1	MOVE	Output while the motor operates.
	2	IN-POS	Output when positioning operation is completed.
	3	START_R	Output in response to an input signal.
	4	HOME-END	Output when high-speed return-to-home operation or return-to-home operation is completed, or position preset is executed.
	5	READY	Output when the driver is ready to operate.
	6	DCMD-RDY	Output when the driver is ready to start direct data operation.
	7	ALM-A	Output the alarm status of the driver. (Normally open)
4	8	TRIG_R	Output in response to an input signal.
	9	TRIG-MODE_R	Output in response to an input signal.
	10	SET-ERR	Output when an error occurs in any of the settings of the operation type, position, operating speed, starting/changing speed rate, stopping deceleration, operating current, or forwarding destination for direct data operation.
	11	EXE-ERR	Output when direct data operation is failed to execute.
	12	DCMD-FULL	Output when data is being written to the buffer area of direct data operation.
	13	STOP_R	Output in response to an input signal.
	14	Reserved	0 is returned.
	15	TLC	Output when the output torque reaches the upper limit value.

- **Present alarm**

Byte	Bit	Name	Description
7	0 to 7	Present alarm	The alarm code presently generated is indicated.
6	8 to 15		

- **Feedback position**

Byte	Bit	Name	Description
11	0 to 7	Feedback position	The present feedback position is indicated. [step] When the wrap function is enabled, the value on the wrap coordinates is indicated.
10	8 to 15		
9	16 to 23		
8	24 to 31		

- **Feedback speed (Hz)**

Byte	Bit	Name	Description
15	0 to 7	Feedback speed [Hz]	The present feedback speed is indicated. [Hz]
14	8 to 15		
13	16 to 23		
12	24 to 31		

- **Command position**

Byte	Bit	Name	Description
19	0 to 7	Command position	The present command position is indicated. [step] When the wrap function is enabled, the value on the wrap coordinates is indicated.
18	8 to 15		
17	16 to 23		
16	24 to 31		

- **Torque monitor**

Byte	Bit	Name	Description
21	0 to 7	Torque monitor	The torque presently generated is indicated as a percentage of the maximum holding torque. (1=0.1 %)
20	8 to 15		

- **CST operating current**

Byte	Bit	Name	Description
23	0 to 7	CST operating current	The operating current of the α control (CST) mode is indicated. (1=0.1 %)
22	8 to 15		

- **Information**

Byte	Bit	Name	Description
27	0 to 7	Information	The information code being generated is indicated.
26	8 to 15		
25	16 to 23		
24	24 to 31		

- **Read parameter ID_R**

Byte	Bit	Name	Description
31	0 to 7	Read parameter ID_R	A response of the read parameter ID is indicated.
30	8 to 15		

- **Read/write status**

Byte	Bit	Name	Description
33	0 to 6	Reserved	0 is returned.
	7	RD-ERR	Output when an error occurred in reading. If reading is performed properly, the RD-ERR is turned OFF
32	8	WR-END	Output in response to the WR-REQ. The WR-END is also turned ON while the WR-REQ is ON. OFF: Write request waiting ON: Write completed
	9	SYS-BSY	Output when the driver is in an internal processing state.
	10	Reserved	0 is returned.
	11	WR-SET-ERR	Output when the write parameter ID or the write data is out of the setting range.
	12	WR-IF-ERR	Output when writing cannot be performed due to user I/F communication in progress.
	13	WR-NV-ERR	Output when writing cannot be performed due to non-volatile memory processing in progress.
	14	WR-EXE-ERR	Output when a command cannot be executed.
	15	WR-ERR	Output when an error occurred in writing. If the WR-REQ is turned OFF or writing is performed properly, the WR-ERR is also turned OFF.

- Write parameter ID_R

Byte	Bit	Name	Description
35	0 to 7	Write parameter ID_R	A response of the write parameter ID is indicated.
34	8 to 15		

- Read data

Byte	Bit	Name	Description
39	0 to 7	Read data	The value of the parameter shown in the parameter ID_R is indicated.
38	8 to 15		
37	16 to 23		
36	24 to 31		

- Assignable monitor

Byte	Bit	Name	Description
55	0 to 7	Assignable monitor 3	The value of the parameter set in the "Assignable monitor address 3" parameter is indicated.
54	8 to 15		
53	16 to 23		
52	24 to 31		
51	0 to 7	Assignable monitor 2	The value of the parameter set in the "Assignable monitor address 2" parameter is indicated.
50	8 to 15		
49	16 to 23		
48	24 to 31		
47	0 to 7	Assignable monitor 1	The value of the parameter set in the "Assignable monitor address 1" parameter is indicated.
46	8 to 15		
45	16 to 23		
44	24 to 31		
43	0 to 7	Assignable monitor 0	The value of the parameter set in the "Assignable monitor address 0" parameter is indicated.
42	8 to 15		
41	16 to 23		
40	24 to 31		

4-3 Output data

Data transferred from the host controller to the driver is called Output data.

■ Output data format

Contents of the Output data are as follows. The order of data is in big-endian format.

Byte	Size (byte)	Description
0, 1	2	Remote I/O (R-IN)
2, 3	2	Operation data number selection
4, 5	2	Fixed I/O (IN)
6, 7	2	Direct data operation operation type
8 to 11	4	Direct data operation position
12 to 15	4	Direct data operation operating speed
16 to 19	4	Direct data operation starting/changing rate
20 to 23	4	Direct data operation stopping deceleration
24, 25	2	Direct data operation operating current
26, 27	2	Direct data operation forwarding destination
28, 29	2	Reserved
30, 31	2	Read parameter ID
32, 33	2	Write request
34, 35	2	Write parameter ID
36 to 39	4	Write data

● Order of 2 byte data

Example: When the direct data operation operating current is set to 1,000 (0x03E8h)

Byte	Size (byte)	Description	Value (Hex)
24	2	Direct data operation operating current (upper)	0x03
25		Direct data operation operating current (lower)	0xE8

● Order of 4 byte data

Example: When the direct data operation position is set to 300,000 (0x000493E0h)

Byte	Size (byte)	Description	Value (Hex)
8	4	Direct data operation position (most significant)	0x00
9		Direct data operation position (upper)	0x04
10		Direct data operation position (lower)	0x93
11		Direct data operation position (least significant)	0xE0

■ Details of Output data

● Remote I/O (R-IN)

This is the I/O accessed via PROFINET.

The assignments of signals can be changed using the "R-IN input function" parameters.

Byte	Bit	Name	Description	Initial assignment
1	0	R-IN0	These are used to execute the signal assigned with the "R-IN input function" parameter.	0: Not used
	1	R-IN1		
	2	R-IN2		
	3	R-IN3		
	4	R-IN4		
	5	R-IN5		
	6	R-IN6		
	7	R-IN7		
0	8	R-IN8		
	9	R-IN9		
	10	R-IN10		
	11	R-IN11		
	12	R-IN12		
	13	R-IN13		
	14	R-IN14		
	15	R-IN15		

● Operation data number selection

Byte	Bit	Name	Description	Initial value
3	0	M0	The operation data number is selected using eight bits.	0
	1	M1		
	2	M2		
	3	M3		
	4	M4		
	5	M5		
	6	M6		
	7	M7		
2	8 to 15	Reserved	A value is disregarded.	

● **Fixed I/O (IN)**

This is the I/O accessed via PROFINET.

Assignments of signals cannot be changed.

Byte	Bit	Name	Description	Initial value
5	0	FW-JOG	This is used to execute JOG operation in the forward direction.	0
	1	RV-JOG	This is used to execute JOG operation in the reverse direction.	
	2	Reserved	A value is disregarded.	
	3	START	This is used to execute stored data operation.	
	4	ZHOME	This is used to execute high-speed return-to-home operation.	
	5	STOP	This is used to stop the motor.	
	6	FREE	This is used to shut off the motor current to put the motor into a non-excitation state. When an electromagnetic brake motor is used, the electromagnetic brake is in a state of releasing the motor shaft.	
	7	ALM-RST	This is used to reset the alarm generated presently.	
4	8	TRIG	This is used to execute direct data operation.	
	9	TRIG-MODE	This is used to set the judgment level for the TRIG. 0: Start at ON edge 1: Start at ON level	
	10	Reserved	A value is disregarded.	
	11	Reserved	A value is disregarded.	
	12	FW-JOG-P	This is used to execute inching operation in the forward direction.	
	13	RV-JOG-P	This is used to execute inching operation in the reverse direction.	
	14	FW-POS	This is used to execute continuous operation in the forward direction.	
	15	RV-POS	This is used to execute continuous operation in the reverse direction.	

● **Direct data operation operation type**

Byte	Bit	Name	Description	Initial value
7	0 to 7	Direct data operation operation type	This is used to set the operation type for direct data operation. [Setting range] 0: No setting 1: Absolute positioning 2: Incremental positioning (based on command position) 3: Incremental positioning (based on feedback position) 7: Continuous operation (position control) 8: Wrap absolute positioning 9: Wrap proximity positioning 10: Wrap absolute positioning (FWD) 11: Wrap absolute positioning (RVS) 12: Wrap absolute push-motion 13: Wrap proximity push-motion 14: Wrap push-motion (FWD) 15: Wrap push-motion (RVS) 16: Continuous operation (speed control) 17: Continuous operation (push-motion) 18: Continuous operation (torque control) 20: Absolute positioning push-motion 21: Incremental positioning push-motion (based on command position) 22: Incremental positioning push-motion (based on feedback position)	2
6	8 to 15			

- Direct data operation position

Byte	Bit	Name	Description	Initial value
11	0 to 7	Direct data operation position	This is used to set the target position for direct data operation. [Setting range] –2,147,483,648 to 2,147,483,647 steps	0
10	8 to 15			
9	16 to 23			
8	24 to 31			

- Direct data operation operating speed

Byte	Bit	Name	Description	Initial value
15	0 to 7	Direct data operation operating speed	This is used to set the operating speed for direct data operation. [Setting range] –4,000,000 to 4,000,000 Hz	1,000
14	8 to 15			
13	16 to 23			
12	24 to 31			

- Direct data operation starting/changing rate

Byte	Bit	Name	Description	Initial value
19	0 to 7	Direct data operation starting/changing rate	This is used to set the starting/changing rate or the starting/changing time for direct data operation. [Setting range] 1 to 1,000,000,000 (1=0.001 kHz/s, 1=0.001 s, or 1=0.001 ms/kHz)	1,000,000
18	8 to 15			
17	16 to 23			
16	24 to 31			

- Direct data operation stopping deceleration

Byte	Bit	Name	Description	Initial value
23	0 to 7	Direct data operation stopping deceleration	This is used to set the stopping deceleration rate or the stop time for direct data operation. [Setting range] 1 to 1,000,000,000 (1=0.001 kHz/s, 1=0.001 s, or 1=0.001 ms/kHz)	1,000,000
22	8 to 15			
21	16 to 23			
20	24 to 31			

- Direct data operation operating current

Byte	Bit	Name	Description	Initial value
25	0 to 7	Direct data operation operating current	This is used to set the operating current for direct data operation. [Setting range] 0 to 1,000 (1=0.1 %)	1,000
24	8 to 15			

- Direct data operation forwarding destination

Byte	Bit	Name	Description	Initial value
27	0 to 7	Direct data operation forwarding destination	This is used to select the stored area when the next direct data is transferred during direct data operation. [Setting range] 0: Execution memory 1: Buffer memory	0
26	8 to 15			

- Read parameter ID

Byte	Bit	Name	Description	Initial value
31	0 to 7	Read parameter ID	This is used to set the parameter ID to be read from.	0
30	8 to 15			

- Write request

Byte	Bit	Name	Description	Initial value
33	0	WR-REQ	This is used to set the write request. [Setting range] 0: Disable (OFF) 1: Write request (ON edge)	0
	1 to 7	Reserved	A value is disregarded.	
32	8 to 15	Reserved	A value is disregarded.	

- Write parameter ID

Byte	Bit	Name	Description	Initial value
35	0 to 7	Write parameter ID	This is used to set the parameter ID to be written to.	0
34	8 to 15			

- Write data

Byte	Bit	Name	Description	Initial value
39	0 to 7	Write data	This is used to set a value to be written to the parameter specified by the write parameter ID.	0
38	8 to 15			
37	16 to 23			
36	24 to 31			

4-4 Processing order of IO data

The processing order of IO data is shown below.

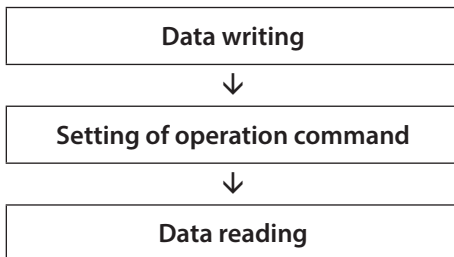

- If multiple operation commands are set, the operation command of direct data operation is prioritized.
- If the operation commands for remote I/O (R-IN) and fixed I/O (IN) are set at the same time, operations are as follows.
 - If the same operation command is set: The motor will start.
 - If different operation commands are set: The motor will not start, and information of Start operation error will be generated.

4-5 Data writing

This section explains the flow that data is written from the host controller to the driver.

■ Area of IO data used

Input (driver → host controller)

Byte	Description
32, 33	Read/write status
34, 35	Write parameter ID_R

Output (host controller → driver)

Byte	Description
32, 33	Write request
34, 35	Write parameter ID
36 to 39	Write data

■ Flow that data is written to

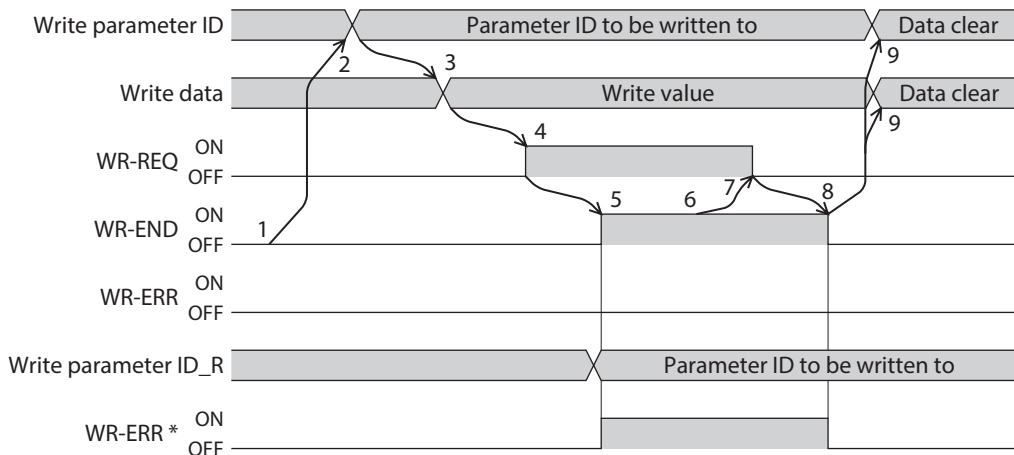
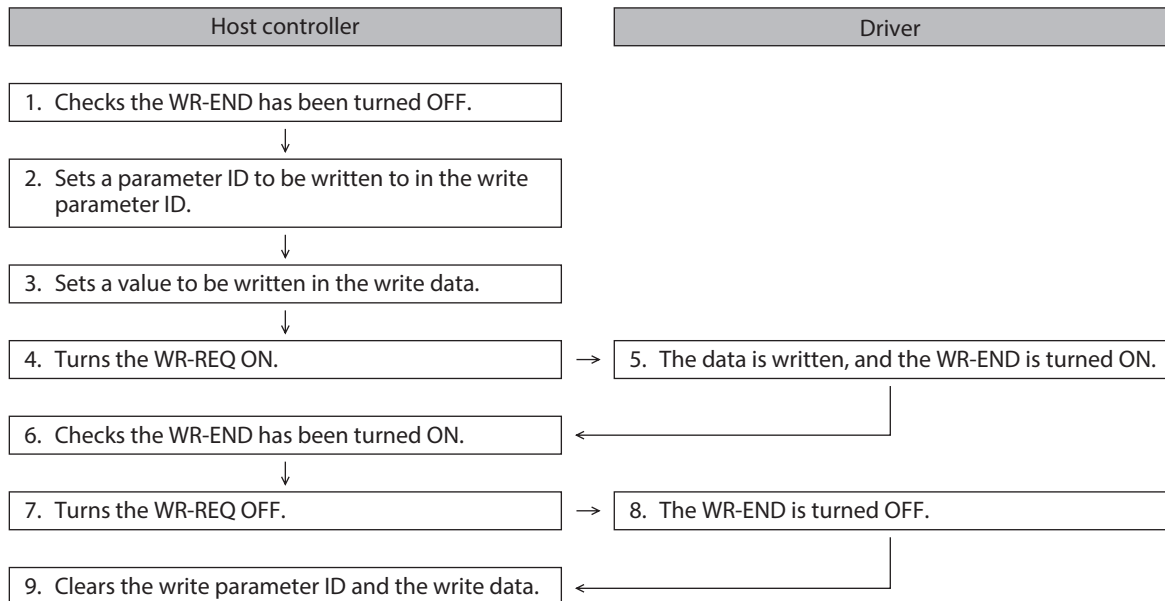

* If an error occurs while data is being written, the WR-END and WR-ERR are simultaneously turned ON.

4-6 Data reading

This section explains the flow that data is read from the driver to the host controller. There are the following two methods to read data.

- Use an area of "Read data"
- Use an area of "Assignable monitor"

■ When an area of read data is used

● Area of IO data used

Input (driver → host controller)

Byte	Description
30, 31	Read parameter ID_R
32, 33	Read/write status
36 to 39	Read data

Output (host controller → driver)

Byte	Description
30, 31	Read parameter ID

● Flow that data is read from

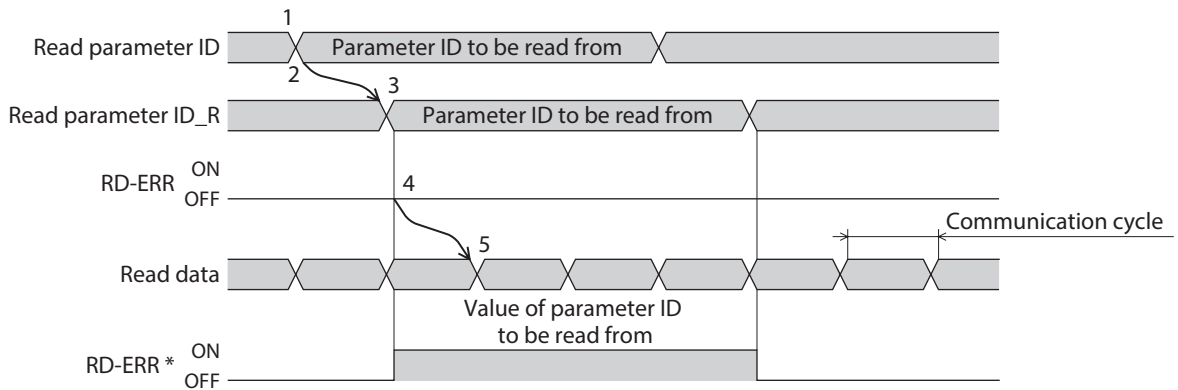
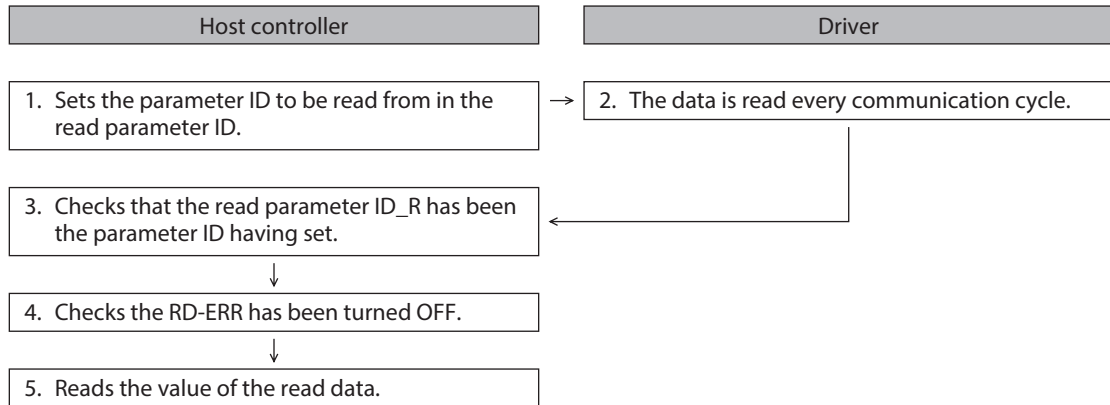

* If the parameter ID out of setting range is set to the read parameter ID, the RD-ERR is turned ON at the same time when the read parameter ID_R is updated.

■ When an area of assignable monitor is used

● Area of IO data used

Input (driver → host controller)

Byte	Description
40 to 55	Assignable monitor 0 to assignable monitor 3

● Flow that data is read from

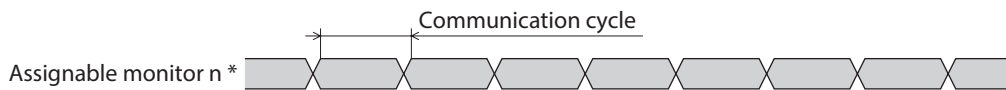
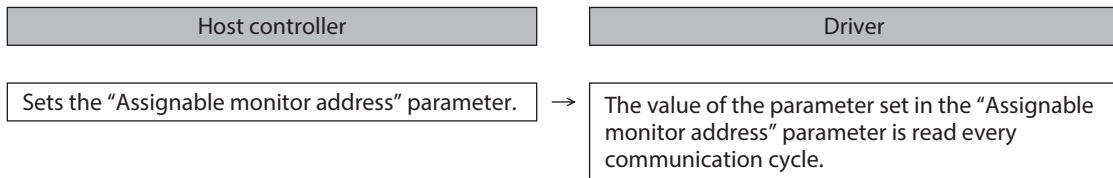

* n: 0 to 3

● Related parameters

Parameter ID		Name	Description	Setting range	Initial value
Dec	Hex				
25600	6400h	Assignable monitor address 0	Sets the parameter ID to show on the assignable monitor.	Set from items of "3 Monitor commands" on p.69.	124: Driver temperature
25601	6401h	Assignable monitor address 1			125: Motor temperature
25602	6402h	Assignable monitor address 2			109: Cumulative load monitor
25603	6403h	Assignable monitor address 3			127: Tripmeter

5 Example of execution for operation

This chapter describes operations that operation data is set using the write data area. The method to execute operation is common to fixed I/O and remote I/O.

Note Before operating the motor, check the condition of the surrounding area to ensure safety.

5-1 Positioning operation

As an example, this section explains how to execute the following positioning operation.

- **Setting example**

- Operation data number: 1
- Position: 5,000 steps
- Other settings: Initial values

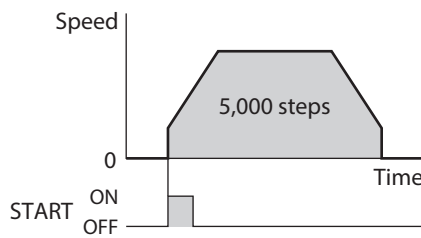

- **Operation processing flow**

Descriptions are given using the host controller as the subject.

1. Set the following operation data to turn the WR-REQ ON.
The operation data is set in the driver. When the setting is completed, the WR-END is turned ON.

- Output (host controller → driver)

Byte	Description	Setting value	Note
34, 35	Write parameter ID	3105	Parameter ID of "Position" of operation data No. 1
36 to 39	Write data	5,000	Position: 5,000 steps

- Input (driver → host controller)

Byte	Description	Response	Note
34, 35	Write parameter ID_R	3105	Parameter ID of "Position" of operation data No. 1

2. Turn the WR-REQ OFF.
The WR-END is returned to OFF.
3. Check the READY has been turned ON.
4. Select the operation data No. 1 to turn the START ON.
Positioning operation is started.
5. Check the READY has been turned OFF, and turn the START OFF.

5-2 Continuous operation

As an example, this section explains how to execute the following continuous operation.

- **Setting example**

- Operation data number: 0
- Rotation direction: Forward direction
- Other settings: Initial values

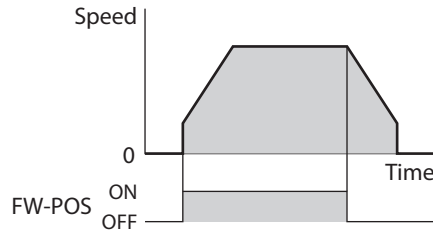

- **Operation processing flow**

Descriptions are given using the host controller as the subject.

1. Check the READY has been turned ON.
2. Set the following operation data to turn the FW-POS ON.
Continuous operation is started.

- Output (host controller → driver)

Byte	Description	Setting value	Note
2, 3	Operation data number selection	0	The operation data No. 0 is selected.

3. To stop continuous operation, turn the FW-POS OFF.
The motor decelerates to a stop.

6 Direct data operation

6-1 Overview of direct data operation

Direct data operation is a mode that allows start of operation at the same time as rewriting of data.

It is suitable to frequently change operation data such as the position (travel amount) and operating speed or to fine-tune the position.

There are the following seven types of triggers to start operation at the same time as rewriting of data.

- One of the following items: Operation type, position, operating speed, starting/changing speed rate, stopping deceleration, and operating current
- The above six items are collectively rewritten

Direct data operation is executed with the TRIG of fixed I/O (IN).

A condition to execute direct data operation can be selected from the following two types using the TRIG-MODE of fixed I/O (IN).

- Start at ON edge of TRIG: The motor will start according to the operation data being set when the TRIG is turned ON.
- Start at ON level of TRIG: The motor will start at the same time when the data of the trigger set in the "Direct data operation trigger setting" parameter is changed.

■ Application example 1 of direct data operation

The position (travel amount) or the operating speed should be adjusted each time a load is changed because the feed rate is different in each load.

● Setting example

- Position (travel amount): Change as desired
- Operating speed: Change as desired
- TRIG-MODE: Start at ON edge of TRIG

● Operation processing flow

Descriptions are given using the host controller as the subject.

1. Write the position and the operating speed.
2. Turn the TRIG ON.

● Result

When the TRIG is turned ON, the changed value is updated immediately, and operation is performed with the new position and operating speed.

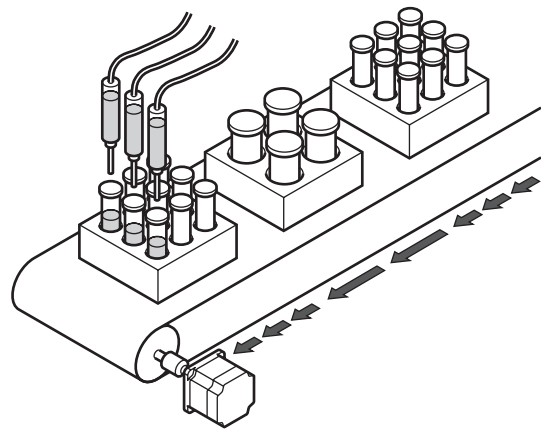

■ Application example 2 of direct data operation

The operating speed should be changed immediately with the touch screen because a large load is inspected at a lower speed.

● Setting example

- Operating speed: Change as desired
- Trigger: Operating speed (setting value of trigger: -4)
- TRIG-MODE: Start at ON level of TRIG

● Operation processing flow

Descriptions are given using the host controller as the subject.

1. Write “-4” to the “Direct data operation trigger setting” parameter.
2. Write the data of the operating speed.
3. Turn the TRIG ON.
4. Change the operating speed.

● Result

When the TRIG is turned ON, operation is started. If the operating speed is changed, the changed value is updated immediately, and the operation is performed at the new operating speed.

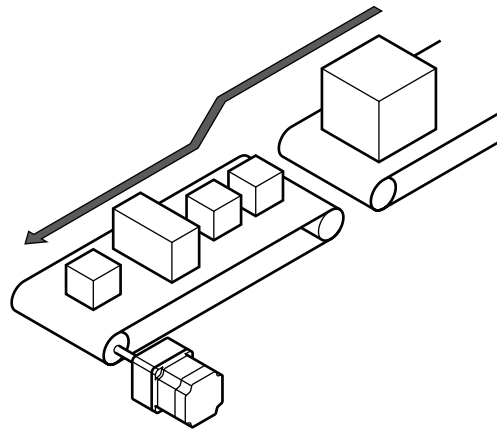

6-2 Output data and parameters required for direct data operation

Related Output data

Byte	Name	Description	Initial value
6, 7	Direct data operation operation type	This is used to set the operation type for direct data operation. [Setting range] 0: No setting 1: Absolute positioning 2: Incremental positioning (based on command position) 3: Incremental positioning (based on feedback position) 7: Continuous operation (Position control) 8: Wrap absolute positioning 9: Wrap proximity positioning 10: Wrap forward direction absolute positioning 11: Wrap reverse direction absolute positioning 12: Wrap absolute push-motion 13: Wrap proximity push-motion 14: Wrap forward direction push-motion 15: Wrap reverse direction push-motion 16: Continuous operation (Speed control) 17: Continuous operation (Push-motion) 18: Continuous operation (Torque control) 20: Absolute positioning push-motion 21: Incremental positioning push-motion (based on command position) 22: Incremental positioning push-motion (based on feedback position)	2
8 to 11	Direct data operation position	This is used to set the target position for direct data operation. [Setting range] -2,147,483,648 to 2,147,483,647 steps	0
12 to 15	Direct data operation operating speed	This is used to set the operating speed for direct data operation. [Setting range] -4,000,000 to 4,000,000 Hz	1,000

Byte	Name	Description	Initial value
16 to 19	Direct data operation starting/changing rate	This is used to set the starting/changing rate or the starting/changing time for direct data operation. [Setting range] 1 to 1,000,000,000 (1=0.001 kHz/s, 1=0.001 s, or 1=0.001 ms/kHz)	1,000,000
20 to 23	Direct data operation stopping deceleration	This is used to set the stopping deceleration rate or the stop time for direct data operation. [Setting range] 1 to 1,000,000,000 (1=0.001 kHz/s, 1=0.001 s, or 1=0.001 ms/kHz)	1,000,000
24, 25	Direct data operation operating current	This is used to set the operating current for direct data operation. [Setting range] 0 to 1,000 (1=0.1 %)	1,000
26, 27	Direct data operation forwarding destination	This is used to select the stored area when the next direct data is transferred during direct data operation. [Setting range] 0: Execution memory 1: Buffer memory	0

Related parameter

Parameter ID		Name	Description	Initial value
Dec	Hex			
24852	6114h	Direct data operation trigger setting	Sets the trigger to execute direct data operation. The trigger setting is enabled only when the TRIG-MODE is set to "1: Start at ON level." [Setting range] -6: Operation type -5: Position -4: Operating speed -3: Starting/changing speed rate -2: Stopping deceleration -1: Operating current 0: Disable 1: All data updated	1

■ Trigger setting

This is a trigger to start operation at the same time as rewriting of data in direct data operation. The trigger setting is enabled only when the TRIG-MODE is set to "1: Start at ON level."

● When the trigger setting is "0"

Direct data operation is disabled.

● When the trigger setting is "1"

When the TRIG is turned from OFF to ON, direct data operation is started. After that, if any of data is changed, the motor will be started. The motor will be started only when data is changed.

● When the trigger setting is "-1 to -6"

When the TRIG is turned from OFF to ON, direct data operation is started. After that, only when the data corresponding to the trigger is changed, the motor will be started. Even if data other than the trigger is changed, the motor will not be started.

■ Forwarding destination

During direct data operation, the stored area when the next direct data is transferred can be selected.

● When the forwarding destination is set to "0: Execution memory"

If the TRIG is turned from OFF to ON or the data corresponding to the trigger is changed, the data during operation can be rewritten to the next direct data.

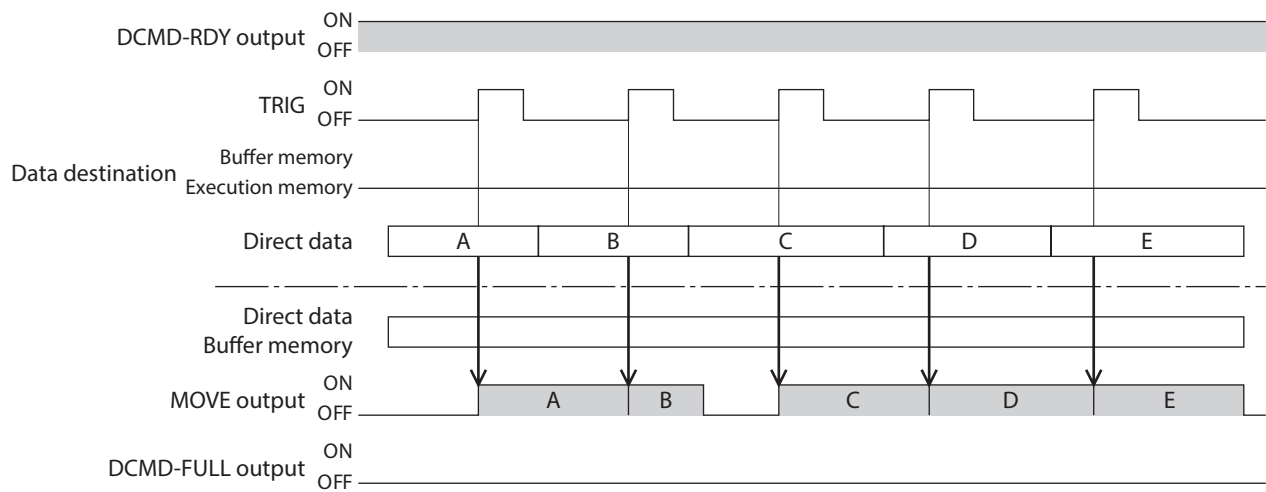

● When the forwarding destination is set to "1: Buffer memory"

If the TRIG is turned from OFF to ON or the data corresponding to the trigger is changed, the next direct data is saved in the buffer memory. When the data during operation is completed, operation of the buffer memory is automatically started. One direct data can be saved in the buffer memory.

If the next direct data is written to the buffer memory, the DCMD-FULL output is turned ON.

During stop or continuous operation, if "Buffer memory" is specified, the data is not stored in the buffer memory and it is rewritten to the next direct data immediately.

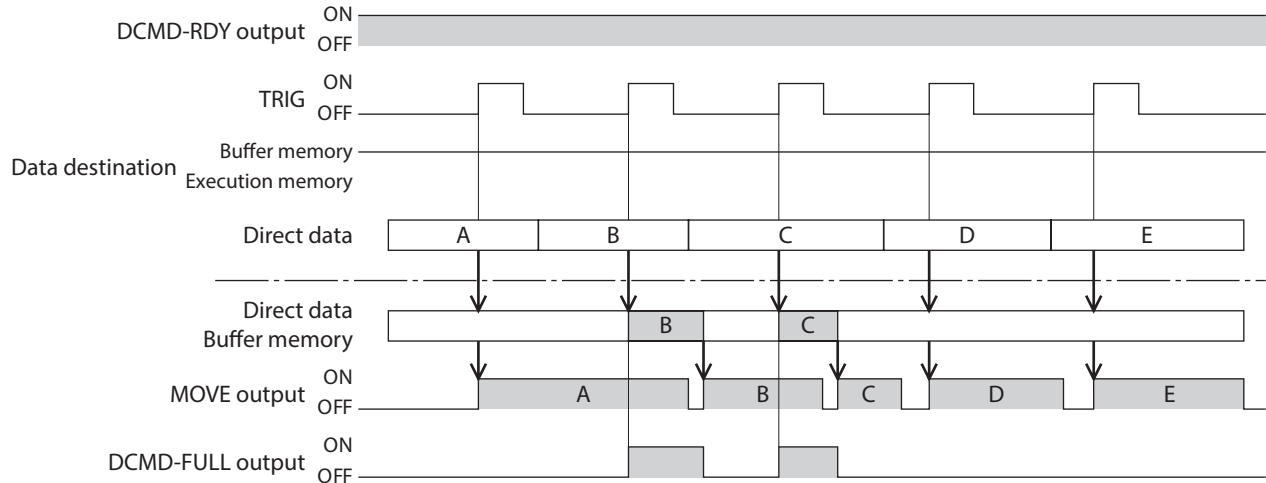

The direct data cannot be written to the buffer memory while the DCMD-FULL output is being ON.

6-3 Operation example

A condition to execute direct data operation can be selected from the ON edge or ON level of TRIG of fixed I/O (IN). A condition can be selected with the TRIG-MODE of fixed I/O (IN).

Note Before operating the motor, check the condition of the surrounding area to ensure safety.

■ When direct data operation is executed at ON edge of TRIG

As an example, this section explains how to execute the following direct data operation.

● Setting example

- Operation type: Incremental positioning (based on command position)
- Position: 5,000 steps
- Operating speed: 1,000 Hz
- Starting/changing speed rate: 1,000 kHz/s
- Stopping deceleration: 1,000 kHz/s
- Operating current: 100 %
- Forwarding destination: Execution memory

● Operation processing flow

Descriptions are given using the host controller as the subject.

1. Check the DCMD-RDY has been turned ON.
2. Set the following data.

• Output (host controller → driver)

Byte	Description	Setting value	Note
4, 5	TRIG-MODE (bit 9 of fixed I/O (IN))	0	Start at ON edge
6, 7	Direct data operation operation type	2	Incremental positioning (based on command position)
8 to 11	Direct data operation position	5,000	5,000 steps
12 to 15	Direct data operation operating speed	1,000	1,000 Hz
16 to 19	Direct data operation starting/changing rate	1,000,000	1,000 kHz/s
20 to 23	Direct data operation stopping deceleration	1,000,000	1,000 kHz/s
24, 25	Direct data operation operating current	1,000	100 %
26, 27	Direct data operation forwarding destination	0	Execution memory

3. Turn the TRIG ON.
Direct data operation is started.
4. Check the TRIG_R has been turned ON, and turn the TRIG OFF.

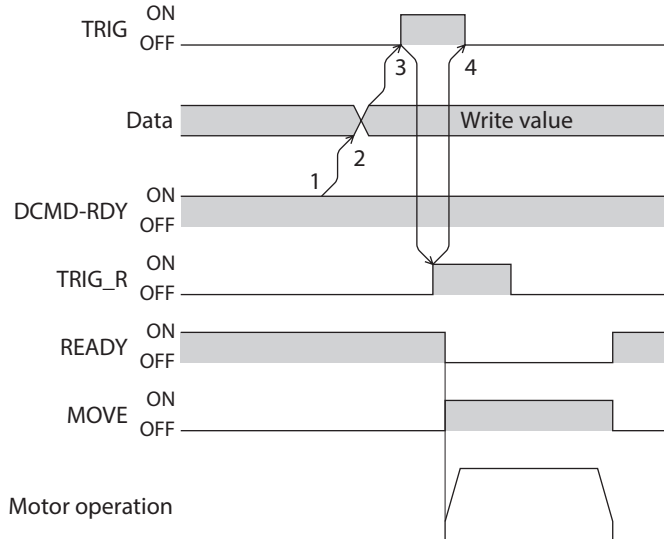

■ When direct data operation is executed at ON level of TRIG

This section explains how to execute the following direct data operation with setting the trigger to "Position."
Set the trigger with the "Direct data operation trigger setting" parameter.

● Setting example

- Operation 1
Position: 7,000 steps
- Operation 2
Position: 3,000 steps
- Other settings

Description	Setting value
Operation type	Incremental positioning (based on command position)
Operating speed	1,000 Hz
Starting/changing rate	1,000 kHz/s

Description	Setting value
Stopping deceleration	1,000 kHz/s
Operating current	100 %
Forwarding destination	Execution memory

● Operation processing flow

Descriptions are given using the host controller as the subject.

1. Set the following parameters to turn the WR-REQ ON.
The parameter information is set to the driver. When the setting is completed, the WR-END is turned ON.

● Output (host controller → driver)

Byte	Description	Setting value	Note
34, 35	Write parameter ID	24852	Parameter ID of "Direct data operation trigger setting"
36 to 39	Write data	-5	Position

2. Turn the WR-REQ OFF.
The WR-END is returned to OFF.
3. Check the DCMD-RDY has been turned ON.
4. Set the following data.

● Output (host controller → driver)

Byte	Description	Setting value	Note
4, 5	TRIG-MODE (bit 9 of fixed I/O (IN))	1	Start at ON level
6, 7	Direct data operation operation type	2	Incremental positioning (based on command position)
8 to 11	Direct data operation position	7,000	7,000 steps
12 to 15	Direct data operation operating speed	1,000	1,000 Hz
16 to 19	Direct data operation starting/changing rate	1,000,000	1,000 kHz/s
20 to 23	Direct data operation stopping deceleration	1,000,000	1,000 kHz/s
24, 25	Direct data operation operating current	1,000	100 %
26, 27	Direct data operation forwarding destination	0	Execution memory

5. Turn the TRIG ON.
Direct data operation of the operation 1 is started.

6. Check the operation 1 is completed, and set the following data.
 Direct data operation of the operation 2 is started.

• Output (host controller → driver)

Byte	Description	Setting value	Note
8 to 11	Direct data operation position	3,000	3,000 steps



- To execute direct data operation of the operation 2, set a different value from the operation 1 in the “Position” of the operation 2.
- If a value other than the “Position” is changed, direct data operation of the operation 2 will not be executed.

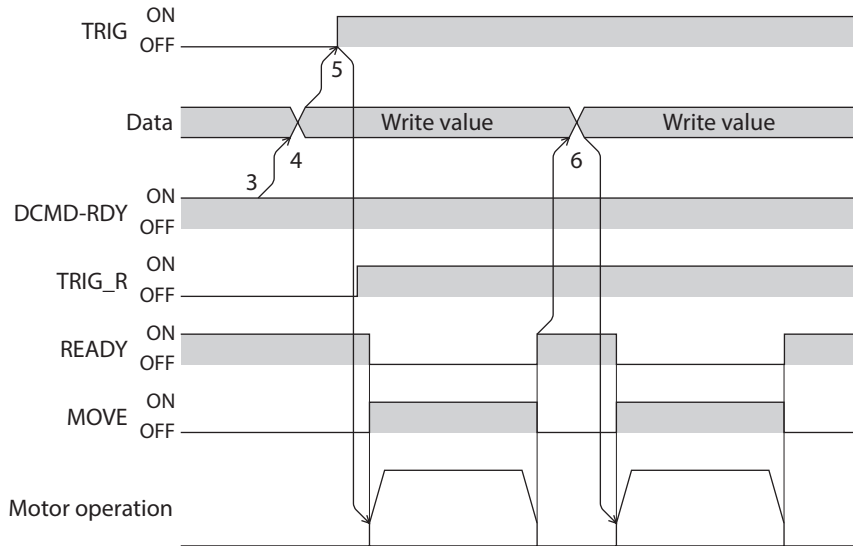

4 Parameter ID lists

This part describes the parameter ID lists to be set via PROFINET.
Data and parameters described here can also be set using the MEXE02 software.

◆ Table of contents

1	Timing for parameter to update	66		
2	Maintenance commands.....	67		
3	Monitor commands.....	69		
4	Operation data R/W commands	75		
	4-1 Base address of each operation data number.....	75		
	4-2 Parameter ID.....	77		
	4-3 Setting example.....	78		
5	Operation I/O event R/W commands	79		
	5-1 Base address of operation I/O event.....	79		
	5-2 Parameter ID for operation I/O event R/W command.....	79		
6	Protect release commands	80		
7	Extended operation data setting R/W command.....	81		
8	Parameter R/W commands	82		
	8-1 Driver action simulation setting parameter.....	82		
	8-2 Base setting parameter.....	82		
	8-3 Coordinate parameters.....	83		
	8-4 Operation parameters.....	83		
	8-5 Direct data operation parameters	83		
	8-6 ABZO sensor setting parameters	84		
	8-7 Mechanism settings parameters.....	84		
	8-8 Initial coordinate generation & wrap coordinate parameters.....	84		
	8-9 JOG/HOME/ZHOME operation information setting parameters	85		
	8-10 Alarm setting parameters.....	86		
	8-11 Information setting parameters.....	86		
	8-12 I/O parameters.....	88		
	8-13 Direct I/O setting parameters.....	91		
	8-14 Remote I/O setting parameters	91		
	8-15 Virtual input parameters.....	92		
	8-16 User output setting parameters.....	93		
	8-17 Driver mode setting parameters.....	93		
	8-18 Assignable monitor setting parameters.....	93		
9	I/O signals assignment list.....	94		
	9-1 Input signals	94		
	9-2 Output signals	95		

1 Timing for parameter to update

All data used with the driver is 32 bits wide.

Parameters are saved in the RAM or non-volatile memory of the driver. Parameters stored in the RAM are erased once the main power supply and control power supply are shut off, however, those stored in the non-volatile memory are retained even if these power supplies are shut off.

When the control power supply of the driver is turned on, the parameters stored in the non-volatile memory are transferred to the RAM, and recalculation and setup for the parameters are executed in the RAM.

Parameters having set using the parameter ID are stored in the RAM. To save the parameters stored in the RAM to the non-volatile memory, execute the "Write batch NV memory" of the maintenance command.

When a parameter is changed, the timing to update the new value varies depending on the parameter. Refer to "Notation rules" for details about the update timing.

Note Do not shut off the main power supply and the control power supply while writing the data to the non-volatile memory, and also do not shut off for five seconds after the completion of writing the data. Doing so may abort the data write and cause an alarm of EEPROM error (alarm code 41h) to generate.

- memo**
- Parameters having set using the parameter ID are stored in the RAM. For parameters which update timing is "Update after turning on the main power supply and control power supply again," be sure to save in the non-volatile memory before turning off the power supply.
 - The non-volatile memory can be rewritten approximately 100,000 times.

■ Notation rules

● Timing to update

In this part, each update timing is represented in an alphabet.

Notation	Update timing	Description
A	Immediately	Recalculation and setup are immediately executed when the parameter is written.
B	After operation stop	Recalculation and setup are executed when the operation is stopped.
C	After executing Configuration	Recalculation and setup are executed after Configuration is executed or the main power supply and control power supply are turned on again.
D	After turning on the main power and control power supplies again	Recalculation and setup are executed after the main power supply and control power supply are turned on again.

● READ and WRITE

READ/WRITE may be represented as follows in this manual.

Notation	Description
R	READ
W	WRITE
R/W	READ/WRITE

2 Maintenance commands

Maintenance commands are used to execute the alarm reset, clear latch information, batch processing of the non-volatile memory and others.

Refer to the **AZ Series OPERATING MANUAL Function Edition** for details about parameters. When checking the **AZ Series OPERATING MANUAL Function Edition**, use the parameter name instead of the parameter ID.

Note The maintenance commands include processing in which the memory is operated, such as batch processing of the non-volatile memory and P-PRESET execution. Exercise caution not to execute them unnecessarily in succession.

Parameter ID		Name	Setting range	Initial value
Dec	Hex			
192	00C0h	Alarm reset	-	-
194	00C2h	Clear alarm history		
197	00C5h	P-PRESET execution		
198	00C6h	Configuration		
199	00C7h	Batch data initialization (excluding communication parameters) *1		
200	00C8h	Read batch NV memory		
201	00C9h	Write batch NV memory		
202	00CAh	All data batch initialization (including communication parameters) *2		
203	00CBh	Read from backup		
204	00CCh	Write to backup		
205	00CDh	Clear latch information		
206	00CEh	Clear sequence history		
207	00CFh	Clear tripmeter		
209	00D1h	ZSG-PRESET		
210	00D2h	Clear ZSG-PRESET		
211	00D3h	Clear information		
212	00D4h	Clear information history		
213	00D5h	Alarm history details		

*1 Excluding communication settings of PROFINET

*2 Including communication settings of PROFINET

■ Configuration

Configuration can be executed when all of the following conditions are satisfied.

- An alarm is not being generated.
- The motor is not operated.
- I/O test, teaching/remote operation, teaching function, and download are not being performed with the **MEXE02** software.

The table below shows the driver status before and after Configuration is executed.

Item	Configuration is ready to execute	Configuration is being executed	After executing Configuration
PWR/ALM LED	Green light	Blinking blue	Based on the driver condition.
Electromagnetic brake	Hold/Release	Hold	
Motor excitation	Excitation/non-excitation	Non-excitation	
Output signal	Enable	Disable	Enable
Input signal	Enable	Disable	Enable



Even if monitor is executed while Configuration is being executed, the correct monitor value may not return.

3 Monitor commands

Monitor commands are used to monitor the command position, the command speed, the alarm history, and the information history, etc.

All commands are used for read (READ).

Refer to the **AZ** Series [OPERATING MANUAL Function Edition](#) for details about parameters. When checking the **AZ** Series [OPERATING MANUAL Function Edition](#), use the parameter name instead of the parameter ID.

Parameter ID		Name
Dec	Hex	
64	0040h	Present alarm
65	0041h	Alarm history 1
66	0042h	Alarm history 2
67	0043h	Alarm history 3
68	0044h	Alarm history 4
69	0045h	Alarm history 5
70	0046h	Alarm history 6
71	0047h	Alarm history 7
72	0048h	Alarm history 8
73	0049h	Alarm history 9
74	004Ah	Alarm history 10
97	0061h	Present selected data number
98	0062h	Present operation data number
99	0063h	Command position
100	0064h	Command speed [r/min]
101	0065h	Command speed [Hz]
102	0066h	Feedback position
103	0067h	Feedback speed [r/min]
104	0068h	Feedback speed [Hz]
105	0069h	Remaining dwell time
106	006Ah	Direct I/O
107	006Bh	Torque monitor (1=0.1 %)
109	006Dh	Cumulative load monitor
111	006Fh	Target position
112	0070h	Next number
113	0071h	Loop origin number
114	0072h	Loop count
115	0073h	Event monitor command position (NEXT)
116	0074h	Event monitor feedback position (NEXT)
117	0075h	Event monitor command position (JUMP0 – Low event)
118	0076h	Event monitor feedback position (JUMP0 – Low event)
119	0077h	Event monitor command position (JUMP1 – High event)
120	0078h	Event monitor feedback position (JUMP1 – High event)
121	0079h	Event monitor command position (Operation stop)
122	007Ah	Event monitor feedback position (Operation stop)
123	007Bh	Information
124	007Ch	Driver temperature (1=0.1 °C)
125	007Dh	Motor temperature (1=0.1 °C)
126	007Eh	Odometer (1=0.1 kRev)

Parameter ID		Name
Dec	Hex	
127	007Fh	Tripmeter (1=0.1 kRev)
128	0080h	Sequence history 1
129	0081h	Sequence history 2
130	0082h	Sequence history 3
131	0083h	Sequence history 4
132	0084h	Sequence history 5
133	0085h	Sequence history 6
134	0086h	Sequence history 7
135	0087h	Sequence history 8
136	0088h	Sequence history 9
137	0089h	Sequence history 10
138	008Ah	Sequence history 11
139	008Bh	Sequence history 12
140	008Ch	Sequence history 13
141	008Dh	Sequence history 14
142	008Eh	Sequence history 15
143	008Fh	Sequence history 16
144	0090h	Feedback position 32-bit counter
145	0091h	Command position 32-bit counter
146	0092h	CST operating current (1=0.1 %)
147	0093h	Loop count buffer
160	00A0h	Main power supply count
161	00A1h	Main power supply time [min]
162	00A2h	Control power supply count*
163	00A3h	Inverter voltage (1=0.1 V)
164	00A4h	Main power supply voltage (1=0.1 V)
167	00A7h	ROT SW1
169	00A9h	Elapsed time from BOOT [ms]
184	00B8h	I/O status 1
185	00B9h	I/O status 2
186	00BAh	I/O status 3
187	00BBh	I/O status 4
188	00BCh	I/O status 5
189	00BDh	I/O status 6
190	00BEh	I/O status 7
191	00BFh	I/O status 8
1280	0500h	Alarm history details (Alarm code)
1281	0501h	Alarm history details (Sub code)
1282	0502h	Alarm history details (Driver temperature)
1283	0503h	Alarm history details (Motor temperature)
1284	0504h	Alarm history details (Inverter voltage)
1285	0505h	Alarm history details (Physical I/O input)
1286	0506h	Alarm history details (R-I/O output)
1287	0507h	Alarm history details (Operation information 0)
1288	0508h	Alarm history details (Operation information 1)
1289	0509h	Alarm history details (Feedback position)
1290	050Ah	Alarm history details (Elapsed time from Boot) [ms]

Parameter ID		Name
Dec	Hex	
1291	050Bh	Alarm history details (Elapsed time from starting operation) [ms]
1292	050Ch	Alarm history details (Main power supply time) [min]
1296	0510h	Information history 1
1297	0511h	Information history 2
1298	0512h	Information history 3
1299	0513h	Information history 4
1300	0514h	Information history 5
1301	0515h	Information history 6
1302	0516h	Information history 7
1303	0517h	Information history 8
1304	0518h	Information history 9
1305	0519h	Information history 10
1306	051Ah	Information history 11
1307	051Bh	Information history 12
1308	051Ch	Information history 13
1309	051Dh	Information history 14
1310	051Eh	Information history 15
1311	051Fh	Information history 16
1312	0520h	Information time history 1 [ms]
1313	0521h	Information time history 2 [ms]
1314	0522h	Information time history 3 [ms]
1315	0523h	Information time history 4 [ms]
1316	0524h	Information time history 5 [ms]
1317	0525h	Information time history 6 [ms]
1318	0526h	Information time history 7 [ms]
1319	0527h	Information time history 8 [ms]
1320	0528h	Information time history 9 [ms]
1321	0529h	Information time history 10 [ms]
1322	052Ah	Information time history 11 [ms]
1323	052Bh	Information time history 12 [ms]
1324	052Ch	Information time history 13 [ms]
1325	052Dh	Information time history 14 [ms]
1326	052Eh	Information time history 15 [ms]
1327	052Fh	Information time history 16 [ms]
1472	05C0h	Latch monitor status (NEXT)
1473	05C1h	Latch monitor command position (NEXT)
1474	05C2h	Latch monitor feedback position (NEXT)
1475	05C3h	Latch monitor target position (NEXT)
1476	05C4h	Latch monitor operation number (NEXT)
1477	05C5h	Latch monitor number of loop (NEXT)
1480	05C8h	Latch monitor status (I/O event – Low event)
1481	05C9h	Latch monitor command position (I/O event – Low event)
1482	05CAh	Latch monitor feedback position (I/O event – Low event)
1483	05CBh	Latch monitor target position (I/O event – Low event)
1484	05CCh	Latch monitor operation number (I/O event – Low event)
1485	05CDh	Latch monitor number of loop (I/O event – Low event)
1488	05D0h	Latch monitor status (I/O event – High event)

Parameter ID		Name
Dec	Hex	
1489	05D1h	Latch monitor command position (I/O event – High event)
1490	05D2h	Latch monitor feedback position (I/O event – High event)
1491	05D3h	Latch monitor target position (I/O event – High event)
1492	05D4h	Latch monitor operation number (I/O event – High event)
1493	05D5h	Latch monitor number of loop (I/O event – High event)
1496	05D8h	Latch monitor status (Operation stop)
1497	05D9h	Latch monitor command position (Operation stop)
1498	05DAh	Latch monitor feedback position (Operation stop)
1499	05DBh	Latch monitor target position (Operation stop)
1500	05DCh	Latch monitor operation number (Operation stop)
1501	05DDh	Latch monitor number of loop (Operation stop)

* It will be the number of times the main power supply is turned on if the control power supply is not connected.

■ Direct I/O

The arrangement of bits for direct input is indicated.

Bit 31	Bit 30	Bit 29	Bit 28	Bit 27	Bit 26	Bit 25	Bit 24
–	–	–	–	–	–	–	–
Bit 23	Bit 22	Bit 21	Bit 20	Bit 19	Bit 18	Bit 17	Bit 16
–	–	–	–	–	–	–	–
Bit 15	Bit 14	Bit 13	Bit 12	Bit 11	Bit 10	Bit 9	Bit 8
VIR-IN3	VIR-IN2	VIR-IN1	VIR-IN0	–	–	–	–
Bit 7	Bit 6	Bit 5	Bit 4	Bit 3	Bit 2	Bit 1	Bit 0
–	–	–	–	–	–	IN1	IN0

■ I/O status

The arrangement of bits for internal I/O is indicated.

● Input signals

Parameter ID	Description							
184 (00B8h)	Bit 31	Bit 30	Bit 29	Bit 28	Bit 27	Bit 26	Bit 25	Bit 24
	SLIT	HOMES	RV-LS	FW-LS	RV-BLK	FW-BLK	–	–
	Bit 23	Bit 22	Bit 21	Bit 20	Bit 19	Bit 18	Bit 17	Bit 16
	SPD-LMT	CRNT-LMT	T-MODE	–	–	CCM	–	HMI
	Bit 15	Bit 14	Bit 13	Bit 12	Bit 11	Bit 10	Bit 9	Bit 8
	–	INFO-CLR	LAT-CLR	–	–	EL-PRST	P-PRESET	ALM-RST
	Bit 7	Bit 6	Bit 5	Bit 4	Bit 3	Bit 2	Bit 1	Bit 0
BREAK-ATSQ	PAUSE	STOP	STOP-COFF	CLR	C-ON	FREE	Not used	
185 (00B9h)	Bit 31	Bit 30	Bit 29	Bit 28	Bit 27	Bit 26	Bit 25	Bit 24
	–	–	RV-PSH	FW-PSH	RV-SPD	FW-SPD	RV-POS	FW-POS
	Bit 23	Bit 22	Bit 21	Bit 20	Bit 19	Bit 18	Bit 17	Bit 16
	RV-JOG-C	FW-JOG-C	RV-JOG-P	FW-JOG-P	RV-JOG-H	FW-JOG-H	RV-JOG	FW-JOG
	Bit 15	Bit 14	Bit 13	Bit 12	Bit 11	Bit 10	Bit 9	Bit 8
	D-SEL7	D-SEL6	D-SEL5	D-SEL4	D-SEL3	D-SEL2	D-SEL1	D-SEL0
	Bit 7	Bit 6	Bit 5	Bit 4	Bit 3	Bit 2	Bit 1	Bit 0
–	–	ZHOME	HOME	NEXT	–	SSTART	START	

Parameter ID	Description							
186 (00BAh)	Bit 31	Bit 30	Bit 29	Bit 28	Bit 27	Bit 26	Bit 25	Bit 24
	R15	R14	R13	R12	R11	R10	R9	R8
	Bit 23	Bit 22	Bit 21	Bit 20	Bit 19	Bit 18	Bit 17	Bit 16
	R7	R6	R5	R4	R3	R2	R1	R0
	Bit 15	Bit 14	Bit 13	Bit 12	Bit 11	Bit 10	Bit 9	Bit 8
	–	–	–	–	TEACH	–	–	–
	Bit 7	Bit 6	Bit 5	Bit 4	Bit 3	Bit 2	Bit 1	Bit 0
M7	M6	M5	M4	M3	M2	M1	M0	
187 (00BBh)	Bit 31	Bit 30	Bit 29	Bit 28	Bit 27	Bit 26	Bit 25	Bit 24
	–	–	–	–	–	–	–	–
	Bit 23	Bit 22	Bit 21	Bit 20	Bit 19	Bit 18	Bit 17	Bit 16
	–	–	–	–	–	–	–	–
	Bit 15	Bit 14	Bit 13	Bit 12	Bit 11	Bit 10	Bit 9	Bit 8
	–	–	–	–	–	–	–	–
	Bit 7	Bit 6	Bit 5	Bit 4	Bit 3	Bit 2	Bit 1	Bit 0
–	–	–	–	–	–	–	–	

● Output signals

Parameter ID	Description							
188 (00BCh)	Bit 31	Bit 30	Bit 29	Bit 28	Bit 27	Bit 26	Bit 25	Bit 24
	MAREA	–	TIM	RND-ZERO	ZSG	RV-SLS	FW-SLS	RND-OVF
	Bit 23	Bit 22	Bit 21	Bit 20	Bit 19	Bit 18	Bit 17	Bit 16
	ORGN-STLD	PRST-STLD	PRST-DIS	–	–	ELPRST-MON	ABSPEN	HOME-END
	Bit 15	Bit 14	Bit 13	Bit 12	Bit 11	Bit 10	Bit 9	Bit 8
	AUTO-CD	CRNT	VA	TLC	–	IN-POS	–	SYS-BSY
Bit 7	Bit 6	Bit 5	Bit 4	Bit 3	Bit 2	Bit 1	Bit 0	
INFO	MOVE	–	READY	SYS-RDY	ALM-B	ALM-A	CONST-OFF	
189 (00BDh)	Bit 31	Bit 30	Bit 29	Bit 28	Bit 27	Bit 26	Bit 25	Bit 24
	–	–	–	–	–	–	–	–
	Bit 23	Bit 22	Bit 21	Bit 20	Bit 19	Bit 18	Bit 17	Bit 16
	–	–	USR-OUT1	USR-OUT0	–	–	–	–
	Bit 15	Bit 14	Bit 13	Bit 12	Bit 11	Bit 10	Bit 9	Bit 8
	–	–	–	–	–	–	MBC	MPS
Bit 7	Bit 6	Bit 5	Bit 4	Bit 3	Bit 2	Bit 1	Bit 0	
AREA7	AREA6	AREA5	AREA4	AREA3	AREA2	AREA1	AREA0	
190 (00BEh)	Bit 31	Bit 30	Bit 29	Bit 28	Bit 27	Bit 26	Bit 25	Bit 24
	D-END7	D-END6	D-END5	D-END4	D-END3	D-END2	D-END1	D-END0
	Bit 23	Bit 22	Bit 21	Bit 20	Bit 19	Bit 18	Bit 17	Bit 16
	M-ACT7	M-ACT6	M-ACT5	M-ACT4	M-ACT3	M-ACT2	M-ACT1	M-ACT0
	Bit 15	Bit 14	Bit 13	Bit 12	Bit 11	Bit 10	Bit 9	Bit 8
	M-CHG	–	DCMD-FULL	DCMD-RDY	–	NEXT-LAT	JUMP1-LAT	JUMP0-LAT
	Bit 7	Bit 6	Bit 5	Bit 4	Bit 3	Bit 2	Bit 1	Bit 0
DELAY-BSY	SEQ-BSY	PAUSE-BSY	OPE-BSY	–	–	SPD-LMTD	CRNT-LMTD	

Parameter ID	Description							
191 (00BFh)	Bit 31	Bit 30	Bit 29	Bit 28	Bit 27	Bit 26	Bit 25	Bit 24
	INFO-RBT	INFO-CFG	INFO-IOTEST	INFO-DSLMTD	–	–	–	–
	Bit 23	Bit 22	Bit 21	Bit 20	Bit 19	Bit 18	Bit 17	Bit 16
	–	–	INFO-ODO	INFO-TRIP	INFO-CULD1	INFO-CULD0	INFO-RV-OT	INFO-FW-OT
	Bit 15	Bit 14	Bit 13	Bit 12	Bit 11	Bit 10	Bit 9	Bit 8
	INFO-NET-E	INFO-RND-E	INFO-EGR-E	–	INFO-PR-REQ	INFO-ZHOME	INFO-START	INFO-SPD
	Bit 7	Bit 6	Bit 5	Bit 4	Bit 3	Bit 2	Bit 1	Bit 0
	–	INFO-OLTIME	INFO-UVOLT	INFO-OVOLT	INFO-MTRTMP	INFO-DRVTMP	INFO-POSERR	INFO-USRIO

4 Operation data R/W commands

This is a method in which the parameter ID (base address) of the base operation data number is specified to input data. Refer to "4-3 Setting example" on p.78 for how to use the base address.

4-1 Base address of each operation data number

Base address		Operation data	Base address		Operation data	Base address		Operation data
Dec	Hex		Dec	Hex		Dec	Hex	
3072	0C00h	No. 0	4320	10E0h	No. 39	5568	15C0h	No. 78
3104	0C20h	No. 1	4352	1100h	No. 40	5600	15E0h	No. 79
3136	0C40h	No. 2	4384	1120h	No. 41	5632	1600h	No. 80
3168	0C60h	No. 3	4416	1140h	No. 42	5664	1620h	No. 81
3200	0C80h	No. 4	4448	1160h	No. 43	5696	1640h	No. 82
3232	0CA0h	No. 5	4480	1180h	No. 44	5728	1660h	No. 83
3264	0CC0h	No. 6	4512	11A0h	No. 45	5760	1680h	No. 84
3296	0CE0h	No. 7	4544	11C0h	No. 46	5792	16A0h	No. 85
3328	0D00h	No. 8	4576	11E0h	No. 47	5824	16C0h	No. 86
3360	0D20h	No. 9	4608	1200h	No. 48	5856	16E0h	No. 87
3392	0D40h	No. 10	4640	1220h	No. 49	5888	1700h	No. 88
3424	0D60h	No. 11	4672	1240h	No. 50	5920	1720h	No. 89
3456	0D80h	No. 12	4704	1260h	No. 51	5952	1740h	No. 90
3488	0DA0h	No. 13	4736	1280h	No. 52	5984	1760h	No. 91
3520	0DC0h	No. 14	4768	12A0h	No. 53	6016	1780h	No. 92
3552	0DE0h	No. 15	4800	12C0h	No. 54	6048	17A0h	No. 93
3584	0E00h	No. 16	4832	12E0h	No. 55	6080	17C0h	No. 94
3616	0E20h	No. 17	4864	1300h	No. 56	6112	17E0h	No. 95
3648	0E40h	No. 18	4896	1320h	No. 57	6144	1800h	No. 96
3680	0E60h	No. 19	4928	1340h	No. 58	6176	1820h	No. 97
3712	0E80h	No. 20	4960	1360h	No. 59	6208	1840h	No. 98
3744	0EA0h	No. 21	4992	1380h	No. 60	6240	1860h	No. 99
3776	0EC0h	No. 22	5024	13A0h	No. 61	6272	1880h	No. 100
3808	0EE0h	No. 23	5056	13C0h	No. 62	6304	18A0h	No. 101
3840	0F00h	No. 24	5088	13E0h	No. 63	6336	18C0h	No. 102
3872	0F20h	No. 25	5120	1400h	No. 64	6368	18E0h	No. 103
3904	0F40h	No. 26	5152	1420h	No. 65	6400	1900h	No. 104
3936	0F60h	No. 27	5184	1440h	No. 66	6432	1920h	No. 105
3968	0F80h	No. 28	5216	1460h	No. 67	6464	1940h	No. 106
4000	0FA0h	No. 29	5248	1480h	No. 68	6496	1960h	No. 107
4032	0FC0h	No. 30	5280	14A0h	No. 69	6528	1980h	No. 108
4064	0FE0h	No. 31	5312	14C0h	No. 70	6560	19A0h	No. 109
4096	1000h	No. 32	5344	14E0h	No. 71	6592	19C0h	No. 110
4128	1020h	No. 33	5376	1500h	No. 72	6624	19E0h	No. 111
4160	1040h	No. 34	5408	1520h	No. 73	6656	1A00h	No. 112
4192	1060h	No. 35	5440	1540h	No. 74	6688	1A20h	No. 113
4224	1080h	No. 36	5472	1560h	No. 75	6720	1A40h	No. 114
4256	10A0h	No. 37	5504	1580h	No. 76	6752	1A60h	No. 115
4288	10C0h	No. 38	5536	15A0h	No. 77	6784	1A80h	No. 116

Base address		Operation data	Base address		Operation data	Base address		Operation data
Dec	Hex		Dec	Hex		Dec	Hex	
6816	1AA0h	No. 117	8320	2080h	No. 164	9824	2660h	No. 211
6848	1AC0h	No. 118	8352	20A0h	No. 165	9856	2680h	No. 212
6880	1AE0h	No. 119	8384	20C0h	No. 166	9888	26A0h	No. 213
6912	1B00h	No. 120	8416	20E0h	No. 167	9920	26C0h	No. 214
6944	1B20h	No. 121	8448	2100h	No. 168	9952	26E0h	No. 215
6976	1B40h	No. 122	8480	2120h	No. 169	9984	2700h	No. 216
7008	1B60h	No. 123	8512	2140h	No. 170	10016	2720h	No. 217
7040	1B80h	No. 124	8544	2160h	No. 171	10048	2740h	No. 218
7072	1BA0h	No. 125	8576	2180h	No. 172	10080	2760h	No. 219
7104	1BC0h	No. 126	8608	21A0h	No. 173	10112	2780h	No. 220
7136	1BE0h	No. 127	8640	21C0h	No. 174	10144	27A0h	No. 221
7168	1C00h	No. 128	8672	21E0h	No. 175	10176	27C0h	No. 222
7200	1C20h	No. 129	8704	2200h	No. 176	10208	27E0h	No. 223
7232	1C40h	No. 130	8736	2220h	No. 177	10240	2800h	No. 224
7264	1C60h	No. 131	8768	2240h	No. 178	10272	2820h	No. 225
7296	1C80h	No. 132	8800	2260h	No. 179	10304	2840h	No. 226
7328	1CA0h	No. 133	8832	2280h	No. 180	10336	2860h	No. 227
7360	1CC0h	No. 134	8864	22A0h	No. 181	10368	2880h	No. 228
7392	1CE0h	No. 135	8896	22C0h	No. 182	10400	28A0h	No. 229
7424	1D00h	No. 136	8928	22E0h	No. 183	10432	28C0h	No. 230
7456	1D20h	No. 137	8960	2300h	No. 184	10464	28E0h	No. 231
7488	1D40h	No. 138	8992	2320h	No. 185	10496	2900h	No. 232
7520	1D60h	No. 139	9024	2340h	No. 186	10528	2920h	No. 233
7552	1D80h	No. 140	9056	2360h	No. 187	10560	2940h	No. 234
7584	1DA0h	No. 141	9088	2380h	No. 188	10592	2960h	No. 235
7616	1DC0h	No. 142	9120	23A0h	No. 189	10624	2980h	No. 236
7648	1DE0h	No. 143	9152	23C0h	No. 190	10656	29A0h	No. 237
7680	1E00h	No. 144	9184	23E0h	No. 191	10688	29C0h	No. 238
7712	1E20h	No. 145	9216	2400h	No. 192	10720	29E0h	No. 239
7744	1E40h	No. 146	9248	2420h	No. 193	10752	2A00h	No. 240
7776	1E60h	No. 147	9280	2440h	No. 194	10784	2A20h	No. 241
7808	1E80h	No. 148	9312	2460h	No. 195	10816	2A40h	No. 242
7840	1EA0h	No. 149	9344	2480h	No. 196	10848	2A60h	No. 243
7872	1EC0h	No. 150	9376	24A0h	No. 197	10880	2A80h	No. 244
7904	1EE0h	No. 151	9408	24C0h	No. 198	10912	2AA0h	No. 245
7936	1F00h	No. 152	9440	24E0h	No. 199	10944	2AC0h	No. 246
7968	1F20h	No. 153	9472	2500h	No. 200	10976	2AE0h	No. 247
8000	1F40h	No. 154	9504	2520h	No. 201	11008	2B00h	No. 248
8032	1F60h	No. 155	9536	2540h	No. 202	11040	2B20h	No. 249
8064	1F80h	No. 156	9568	2560h	No. 203	11072	2B40h	No. 250
8096	1FA0h	No. 157	9600	2580h	No. 204	11104	2B60h	No. 251
8128	1FC0h	No. 158	9632	25A0h	No. 205	11136	2B80h	No. 252
8160	1FE0h	No. 159	9664	25C0h	No. 206	11168	2BA0h	No. 253
8192	2000h	No. 160	9696	25E0h	No. 207	11200	2BC0h	No. 254
8224	2020h	No. 161	9728	2600h	No. 208	11232	2BE0h	No. 255
8256	2040h	No. 162	9760	2620h	No. 209			
8288	2060h	No. 163	9792	2640h	No. 210			

4-2 Parameter ID

The setting item of operation data is set with the operation data R/W command.

The parameter ID for the setting item is arranged based on the base address of the operation data number.

(Base address ⇒ p.75)

For example, in the case of the setting item "Position," 1 is added to the base address.

Parameter ID	Name	Setting range	Initial value	Update
Base address +0	Operation type	1: Absolute positioning 2: Incremental positioning (based on command position) 3: Incremental positioning (based on feedback position) 7: Continuous operation (Position control) 8: Wrap absolute positioning 9: Wrap proximity positioning 10: Wrap forward direction absolute positioning 11: Wrap reverse direction absolute positioning 12: Wrap absolute push-motion 13: Wrap proximity push-motion 14: Wrap forward direction push-motion 15: Wrap reverse direction push-motion 16: Continuous operation (Speed control) 17: Continuous operation (Push-motion) 18: Continuous operation (Torque control) 20: Absolute positioning push-motion 21: Incremental positioning push-motion (based on command position) 22: Incremental positioning push-motion (based on feedback position)	2	B
Base address +1	Position	-2,147,483,648 to 2,147,483,647 steps	0	B
Base address +2	Operating speed	-4,000,000 to 4,000,000 Hz	1,000	B
Base address +3	Starting/changing rate	1 to 1,000,000,000 (1=0.001 kHz/s, 1=0.001 s, or 1=0.001 ms/kHz)	1,000,000	B
Base address +4	Stop	1 to 1,000,000,000 (1=0.001 kHz/s, 1=0.001 s, or 1=0.001 ms/kHz)	1,000,000	B
Base address +5	Operating current	0 to 1,000 (1=0.1 %)	1,000	B
Base address +6	Drive-complete delay time	0 to 65,535 (1=0.001 s)	0	B
Base address +7	Link	0: No link 1: Manual sequential 2: Automatic sequential 3: Continuous sequential operation	0	B
Base address +8	Next data number	-256: Stop -2: ↓↓ (+2) -1: ↓ (+1) 0 to 255: Operation data number	-1	B
Base address +9	Area offset	-2,147,483,648 to 2,147,483,647 steps	0	B
Base address +10	Area width	-1: Disable 0 to 4,194,303: Set by 1 step	-1	B
Base address +11	Loop count	0: None (-) 2 to 255: Number of loops (loop 2 { to loop 255 {)	0	B
Base address +12	Loop offset	-4,194,304 to 4,194,303 steps	0	B
Base address +13	Loop end number	0: None (-) 1: Loop end (} L-End)	0	B
Base address +14	(Low) I/O event number	-1: None (-) 0 to 31: Operation I/O event number (0 to 31)	-1	B
Base address +15	(High) I/O event number	-1: None (-) 0 to 31: Operation I/O event number (0 to 31)	-1	B

4-3 Setting example

As an example, this section explains how to set the following operation data to the operation data No. 0 to No. 2.

Setting item	Operation data No. 0	Operation data No. 1	Operation data No. 2
Operation type	Absolute positioning	Incremental positioning (based on command position)	Incremental positioning (based on feedback position)
Position [step]	1,000	1,000	1,000
Operating speed [Hz]	1,000	1,000	1,000
Operating current [%]	50.0	70.0	100.0

■ Setting of operation data No. 0

Seeing the table on p.75, we can find that the base address of the operation data No. 0 is "3072 (0C00h)." Based on this base address, the parameter ID for the setting item is calculated from the table on p.77.

Setting item	Parameter ID			Setting value
	Calculation method	Dec	Hex	
Operation type	Base address + 0	3072 + 0 = 3072	0C00h	1
Position	Base address + 1	3072 + 1 = 3073	0C01h	1,000
Operating speed	Base address + 2	3072 + 2 = 3074	0C02h	1,000
Operating current	Base address + 5	3072 + 5 = 3077	0C05h	500

■ Setting of operation data No. 1

From the table on p.75, we can find that the base address of the operation data No. 1 is "3104 (0C20h)." Based on this base address, the parameter ID for the setting item is calculated from the table on p.77.

Setting item	Parameter ID			Setting value
	Calculation method	Dec	Hex	
Operation type	Base address + 0	3104 + 0 = 3104	0C20h	2
Position	Base address + 1	3104 + 1 = 3105	0C21h	1,000
Operating speed	Base address + 2	3104 + 2 = 3106	0C22h	1,000
Operating current	Base address + 5	3104 + 5 = 3109	0C25h	700

■ Setting of operation data No. 2

From the table on p.75, we can find that the base address of the operation data No. 2 is "3136 (0C40h)." Based on this base address, the parameter ID for the setting item is calculated from the table on p.77.

Setting item	Parameter ID			Setting value
	Calculation method	Dec	Hex	
Operation type	Base address + 0	3136 + 0 = 3136	0C40h	3
Position	Base address + 1	3136 + 1 = 3137	0C41h	1,000
Operating speed	Base address + 2	3136 + 2 = 3138	0C42h	1,000
Operating current	Base address + 5	3136 + 5 = 3141	0C45h	1,000

5 Operation I/O event R/W commands

If a specified event (ON/OFF of I/O) is generated during operation of the motor, another operation can be started. This is called operation I/O event. This chapter explains the address to execute the operation I/O event.

5-1 Base address of operation I/O event

Base address		Operation I/O event number	Base address		Operation I/O event number	Base address		Operation I/O event number
Dec	Hex		Dec	Hex		Dec	Hex	
2560	0A00h	0	2648	0A58h	11	2736	0AB0h	22
2568	0A08h	1	2656	0A60h	12	2744	0AB8h	23
2576	0A10h	2	2664	0A68h	13	2752	0AC0h	24
2584	0A18h	3	2672	0A70h	14	2760	0AC8h	25
2592	0A20h	4	2680	0A78h	15	2768	0AD0h	26
2600	0A28h	5	2688	0A80h	16	2776	0AD8h	27
2608	0A30h	6	2696	0A88h	17	2784	0AE0h	28
2616	0A38h	7	2704	0A90h	18	2792	0AE8h	29
2624	0A40h	8	2712	0A98h	19	2800	0AF0h	30
2632	0A48h	9	2720	0AA0h	20	2808	0AF8h	31
2640	0A50h	10	2728	0AA8h	21			

5-2 Parameter ID for operation I/O event R/W command

The setting item of operation I/O event is set with the operation I/O event R/W command. The parameter ID for the setting item is arranged based on the base address of the operation I/O event. For example, in the case of the setting item "Dwell," 2 is added to the base address.

Parameter ID	Name	Setting range	Initial value	Update
Base address +0	Link	0: No link 1: Manual sequential 2: Automatic sequential 3: Continuous sequential operation	0	B
Base address +1	Next data number	-256: Stop -2: ↓↓ (+2) -1: ↓ (+1) 0 to 255: Operation data number	-256	B
Base address +2	Dwell	0 to 65,535 (1=0.001 s)	0	B
Base address +3	Event trigger I/O	Input signal list ⇨ p.94 Output signal list ⇨ p.95	0: Not used	B
Base address +4	Event trigger type	0: Non 1: ON (calculated cumulative ms) 2: ON (ms) 3: OFF (calculated cumulative ms) 4: OFF (ms) 5: ON edge 6: OFF edge 7: ON (cumulative ms) 8: OFF (cumulative ms)	0	B
Base address +5	Event trigger counter	0 to 65,535 (1=1 ms or 1=once)	0	B

6 Protect release commands

The key codes to read/write the data from/to the backup area and those to release the function limitation by the HMI input are set.

Refer to the **AZ** Series [OPERATING MANUAL Function Edition](#) for details about parameters. When checking the **AZ** Series [OPERATING MANUAL Function Edition](#), use the parameter name instead of the parameter ID.

Parameter ID		Name	Setting range	Initial value
Dec	Hex			
32	0020h	Backup DATA access key	Refer to the next table.	0
33	0021h	Backup DATA write key		
34	0022h	HMI release key		

Key code table

Process that requires protect release	Command name	Key code
Data writing to backup area	Backup DATA access key	20519253 (01391955h)
	Backup DATA write key	1977326743 (75DB9C97h)
Data reading from backup area	Backup DATA access key	20519253 (01391955h)
Release of limitation by HMI input	HMI release key	864617234 (33890312h)

7 Extended operation data setting R/W command

Parameters for extended operation data setting can be set.

Refer to the **AZ Series OPERATING MANUAL Function Edition** for details about parameters. When checking the **AZ Series OPERATING MANUAL Function Edition**, use the parameter name instead of the parameter ID.

Parameter ID		Name	Setting range	Initial value	Update
Dec	Hex				
320	0140h	Common acceleration rate or time	1 to 1,000,000,000 (1=0.001 kHz/s, 1=0.001 s, or 1=0.001 ms/kHz)	1,000,000	A
321	0141h	Common stopping deceleration	1 to 1,000,000,000 (1=0.001 kHz/s, 1=0.001 s, or 1=0.001 ms/kHz)	1,000,000	A
326	0146h	Rate selection	0: The common rate is used (Common setting) 1: The rate of each operation data is used (Separate setting)	1	A
2048	0800h	Repeat start operation data number	-1: Disable 0 to 255: Operation data number	-1	A
2049	0801h	Repeat end operation data number	-1: Disable 0 to 255: Operation data number	-1	A
2050	0802h	Repeat time	-1: Disable 0 to 100,000,000	-1	A



Rewrite the parameters of the extended operation data setting R/W command while operation is stopped.

8 Parameter R/W commands

These commands are used to write or read parameters.

Refer to the **AZ Series OPERATING MANUAL Function Edition** for details about parameters. When checking the **AZ Series OPERATING MANUAL Function Edition**, use the parameter name instead of the parameter ID.

8-1 Driver action simulation setting parameter

Parameter ID		Name	Setting range	Initial value	Update
Dec	Hex				
511	01FFh	Driver simulation mode	0: Use real motor 1: Virtual motor (when ABZO not connected = no ABZO information) 2: Virtual motor (when ABZO not connected = 1,800 rev wrap enable) 3: Virtual motor (when ABZO not connected = 900 rev wrap enable)	0	D

8-2 Base setting parameter

Parameter ID		Name	Setting range	Initial value	Update
Dec	Hex				
294	0126h	Base current	0 to 1,000 (1=0.1 %)	1,000	A
296	0128h	Stop current	0 to 1,000 (1=0.1 %)	500	
297	0129h	Command filter setting	1: LPF (speed filter) 2: Moving average filter	1	B
298	012Ah	Command filter time constant	0 to 200 ms	1	B
300	012Ch	Smooth drive function	0: Disable 1: Enable	1	C
301	012Dh	Current control mode	0: Follow the CCM input 1: Alpha control mode (CST) 2: Servo emulation mode (SVE)	0	A
302	012Eh	Servo emulation (SVE) ratio	0 to 1,000 (1=0.1 %)	1,000	A
303	012Fh	SVE position loop gain	1 to 50	10	A
304	0130h	SVE speed loop gain	10 to 200	180	A
305	0131h	SVE speed loop integral time constant	100 to 2,000 (1=0.1 ms)	1,000	A
306	0132h	Automatic current cutback function	0: Disable 1: Enable	1	A
307	0133h	Automatic current cutback switching time	0 to 1,000 ms	100	A
308	0134h	Operating current ramp up rate	0 to 100 ms/100 %	0	A
309	0135h	Operating current ramp down rate	0 to 100 ms/100 %	0	A
311	0137h	Resonance suppression control frequency	100 to 2,000 Hz	1,000	A
312	0138h	Resonance suppression control gain	-500 to 500	0	A
313	0139h	Deviation acceleration suppressing gain	0 to 500	45	A
506	01FAh	Main power mode*	-1: Automatic discrimination (discriminates the input power supply voltage automatically) 0: 24 VDC 1: 48 VDC	-1	D

* It is used to set the voltage mode of the main power supply. The voltage mode of the main power supply is discriminated in 50 ms after the main power supply is turned on. Set the "Main power mode" parameter to "0: 24 VDC" or "1: 48 VDC" when the main power supply starts up slowly or the voltage of the main power supply is unstable.

8-3 Coordinate parameters

Parameter ID		Name	Setting range	Initial value	Update
Dec	Hex				
451	01C3h	Software overtravel	-1: Disable 0: Immediate stop 1: Deceleration stop 2: Immediate stop with alarm 3: Deceleration stop with alarm	3	A
452	01C4h	Positive software limit	-2,147,483,648 to 2,147,483,647 steps	2,147,483,647	A
453	01C5h	Negative software limit	-2,147,483,648 to 2,147,483,647 steps	-2,147,483,648	A
454	01C6h	Preset position	-2,147,483,648 to 2,147,483,647 steps	0	A

8-4 Operation parameters

Parameter ID		Name	Setting range	Initial value	Update
Dec	Hex				
322	0142h	Starting speed	0 to 4,000,000 Hz	500	B
327	0147h	Acceleration/deceleration unit	0: kHz/s 1: s 2: ms/kHz	0	C
328	0148h	Permission of absolute positioning without setting absolute coordinates	0: Disable 1: Enable	0	B

8-5 Direct data operation parameters

Parameter ID		Name	Setting range	Initial value	Update
Dec	Hex				
272	0110h	Direct data operation zero speed command action	0: Deceleration stop command 1: Speed zero command	0	B
24852	6114h	Direct data operation trigger setting	-6: Operation type -5: Position -4: Operating speed -3: Starting/changing rate -2: Stopping deceleration -1: Operating current 0: Disable 1: Apply all data	1	A

8-6 ABZO sensor setting parameters

Parameter ID		Name	Setting range	Initial value	Update
Dec	Hex				
2032	07F0h	Mechanism settings	0: Prioritize ABZO setting 1: Manual setting	0	D
2034	07F2h	Initial coordinate generation & wrap coordinate setting	0: Prioritize ABZO setting 1: Manual setting	0	D
2035	07F3h	Mechanism limit parameter setting	0: Follow ABZO setting 1: Disable	0	D
2036	07F4h	Mechanism protection parameter setting	0: Follow ABZO setting 1: Disable	0	D
2037	07F5h	JOG/HOME/ZHOME operation setting	0: Prioritize ABZO setting 1: Manual setting	0	D

8-7 Mechanism settings parameters

Parameter ID		Name	Setting range	Initial value	Update
Dec	Hex				
448	01C0h	Electronic gear A	1 to 65,535	1	C
449	01C1h	Electronic gear B	1 to 65,535	1	
450	01C2h	Motor rotation direction	0: Positive side=Counterclockwise 1: Positive side=Clockwise 2: Positive side=Counterclockwise (the driver parameter is applied) 3: Positive side=Clockwise (the driver parameter is applied)	1	C
2017	07E1h	Mechanism lead pitch	1 to 32,767	1	C
2033	07F1h	Gear ratio setting	0: Gear ratio setting disable 1 to 32,767: Gear ratio (1=0.01)	0	C
2553	09F9h	Mechanism lead decimal digit setting	0: ×1 [mm] 1: ×0.1 [mm] 2: ×0.01 [mm] 3: ×0.001 [mm]	0	C

8-8 Initial coordinate generation & wrap coordinate parameters

Parameter ID		Name	Setting range	Initial value	Update
Dec	Hex				
455	01C7h	Wrap setting	0: Disable 1: Enable	1	C
457	01C9h	Initial coordinate generation & wrap setting range	Refer to p.85. (1=0.1 rev)	10	C
459	01CBh	Initial coordinate generation & wrap range offset ratio	0 to 10,000 (1=0.01 %)	5,000	C
460	01CCh	Initial coordinate generation & wrap range offset value	-536,870,912 to 536,870,911 steps	0	C
461	01CDh	The number of the RND-ZERO output in wrap range	1 to 536,870,911 divisions	1	C

● Value that can be set in the "Initial coordinate generation & wrap setting range" parameter

Since the internal coordinate of the ABZO sensor is 1,800 revolutions (or 900 revolutions), select a value from the table to set in the "Initial coordinate generation & wrap setting range" parameter.

In the table, the values which are surrounded with thick box border cannot be set for the ABZO sensor of 900 revolutions.



The table shows the values when setting with the **MEXE02** software. When setting via PROFINET, multiply the values in the table by 10.

Wrap setting range [rev]						
0.5	1.8	4.8	12.0	25.0	72.0	200.0
0.6	2.0	5.0	12.5	30.0	75.0	225.0
0.8	2.4	6.0	14.4	36.0	90.0	300.0
0.9	2.5	7.2	15.0	37.5	100.0	360.0
1.0	3.0	7.5	18.0	40.0	112.5	450.0
1.2	3.6	8.0	20.0	45.0	120.0	600.0
1.5	4.0	9.0	22.5	50.0	150.0	900.0
1.6	4.5	10.0	24.0	60.0	180.0	1,800.0

8-9 JOG/HOME/ZHOME operation information setting parameters

Parameter ID		Name	Setting range	Initial value	Update
Dec	Hex				
336	0150h	(JOG) Travel amount	1 to 8,388,607 steps	1	B
337	0151h	(JOG) Operating speed	1 to 4,000,000 Hz	1,000	B
338	0152h	(JOG) Acceleration/deceleration	1 to 1,000,000,000 (1=0.001 kHz/s, 1=0.001 s, or 1=0.001 ms/kHz)	1,000,000	B
339	0153h	(JOG) Starting speed	0 to 4,000,000 Hz	500	B
340	0154h	(JOG) Operating speed (high)	1 to 4,000,000 Hz	5,000	B
344	0158h	(ZHOME) Operating speed	1 to 4,000,000 Hz	5,000	B
345	0159h	(ZHOME) Acceleration/deceleration	1 to 1,000,000,000 (1=0.001 kHz/s, 1=0.001 s, or 1=0.001 ms/kHz)	1,000,000	B
346	015Ah	(ZHOME) Starting speed	0 to 4,000,000 Hz	500	B
350	015Eh	JOG/HOME/ZHOME command filter time constant	1 to 200 ms	1	B
351	015Fh	JOG/HOME/ZHOME operating current	0 to 1,000 (1=0.1 %)	1,000	B
352	0160h	(HOME) Home-seeking mode	0: 2 sensors 1: 3 sensors * 2: One-way rotation 3: Push-motion	2	B
353	0161h	(HOME) Starting direction	0: Negative side 1: Positive side	1	B
354	0162h	(HOME) Acceleration/deceleration	1 to 1,000,000,000 (1=0.001 kHz/s, 1=0.001 s, or 1=0.001 ms/kHz)	1,000,000	B
355	0163h	(HOME) Starting speed	1 to 4,000,000 Hz	500	B
356	0164h	(HOME) Operating speed	1 to 4,000,000 Hz	1,000	B
357	0165h	(HOME) Last speed	1 to 10,000 Hz	500	B
358	0166h	(HOME) SLIT detection	0: Disable 1: Enable	0	B
359	0167h	(HOME) TIM/ZSG signal detection	0: Disable 1: TIM output 2: ZSG output	0	B

Parameter ID		Name	Setting range	Initial value	Update
Dec	Hex				
360	0168h	(HOME) Position offset	-2,147,483,647 to 2,147,483,647 steps	0	B
361	0169h	(HOME) Backward steps in 2 sensor home-seeking	0 to 8,388,607 steps	500	B
362	016Ah	(HOME) Operating amount in uni-directional home-seeking	0 to 8,388,607 steps	500	B
363	016Bh	(HOME) Operating current for push-home-seeking	0 to 1,000 (1=0.1 %)	1,000	B
364	016Ch	(HOME) Backward steps after first entry in push-home-seeking	0 to 8,388,607 steps	0	B
365	016Dh	(HOME) Pushing time in push-home-seeking	1 to 65,535 ms	200	B
366	016Eh	(HOME) Backward steps in push-home-seeking	0 to 8,388,607 steps	500	B

* Two input signals are provided for the mini Driver. Return-to-home operation of the 3-sensor mode requires three inputs: HOMES input, FW-LS input, and RV-LS input. Therefore, return-to-home operation of the 3-sensor mode is not recommended for the mini Driver.

8-10 Alarm setting parameters

Parameter ID		Name	Setting range	Initial value	Update
Dec	Hex				
384	0180h	Overload alarm	1 to 300 (1=0.1 s)	50	A
385	0181h	Excessive position deviation alarm	1 to 30,000 (1=0.01 rev)	300	A
24968	6188h	Network bus error alarm	0: Disable 1: Enable	1	A

8-11 Information setting parameters

Parameter ID		Name	Setting range	Initial value	Update
Dec	Hex				
416	01A0h	Driver temperature information (INFO-DRVTMP)	40 to 85 °C	85	A
417	01A1h	Overload time information (INFO-OLTIME)	1 to 300 (1=0.1 s)	50	A
418	01A2h	Speed information (INFO-SPD)	0: Disable 1 to 12,000 r/min	0	A
421	01A5h	Position deviation information (INFO-POSERR)	1 to 30,000 (1=0.01 rev)	300	A
424	01A8h	Motor temperature information (INFO-MTRTMP)	40 to 120 °C	85	A
427	01ABh	Overvoltage information (INFO-OVOLT)	140 to 630 (1=0.1 V)	630	A
428	01ACh	Undervoltage information (INFO-UVOLT)	140 to 630 (1=0.1 V)	140	A
431	01AFh	Trip meter information (INFO-TRIP)	0: Disable 1 to 2,147,483,647 (1=0.1 kRev)	0	A
432	01B0h	Odometer information (INFO-ODO)	0: Disable 1 to 2,147,483,647 (1=0.1 kRev)	0	A
433	01B1h	Cumulative load 0 information (INFO-CULD0)	0 to 2,147,483,647	0	A

Parameter ID		Name	Setting range	Initial value	Update
Dec	Hex				
434	01B2h	Cumulative load 1 information (INFO-CULD1)	0 to 2,147,483,647	0	A
435	01B3h	Cumulative load value auto clear	0: Disable 1: Enable	1	A
436	01B4h	Cumulative load value count divisor	1 to 32,767	1	A
444	01BCh	INFO-USRIO output selection	Output signals list ⇨ p.95	128: CONST-OFF	A
445	01BDh	INFO-USRIO output inversion	0: Not invert 1: Invert	0	A
446	01BEh	Information LED condition	0: Disable (LED does not blink) 1: Enable (LED blinks)	1	A
447	01BFh	Information auto clear	0: Disabled (not turned OFF automatically) 1: Enabled (turned OFF automatically)	1	A
1952	07A0h	INFO action (Assigned I/O status information (INFO-USRIO))	0: No info reflect (Only the bit output is ON.) 1: Info reflect (The bit output and the INFO output are ON and the LED blinks.)	1	A
1953	07A1h	INFO action (Position deviation information (INFO-POSERR))			
1954	07A2h	INFO action (Driver temperature information (INFO-DRVTMP))			
1955	07A3h	INFO action (Motor temperature information (INFO-MTRTMP))			
1956	07A4h	INFO action (Overvoltage information (INFO-OVOLT))			
1957	07A5h	INFO action (Undervoltage information (INFO-UVOLT))			
1958	07A6h	INFO action (Overload time information (INFO-OLTIME))			
1960	07A8h	INFO action (Speed information (INFO-SPD))			
1961	07A9h	INFO action (Start operation error information (INFO-START))			
1962	07AAh	INFO action (Start ZHOME error information (INFO-ZHOME))			
1963	07ABh	INFO action (PRESET request information (INFO-PR-REQ))			
1965	07ADh	INFO action (Electronic gear setting error information (INFO-EGR-E))			
1966	07AEh	INFO action (Wrap setting error information (INFO-RND-E))			
1968	07B0h	INFO action (Forward operation prohibition information (INFO-FW-OT))			
1969	07B1h	INFO action (Reverse operation prohibition information (INFO-RV-OT))			
1970	07B2h	INFO action (Cumulative load 0 information (INFO-CULD0))			
1971	07B3h	INFO action (Cumulative load 1 information (INFO-CULD1))			
1972	07B4h	INFO action (Tripmeter information (INFO-TRIP))			

Parameter ID		Name	Setting range	Initial value	Update
Dec	Hex				
1973	07B5h	INFO action (Odometer information (INFO-ODO))	0: No info reflect (Only the bit output is ON.) 1: Info reflect (The bit output and the INFO output are ON and the LED blinks.)	1	A
1980	07BCh	INFO action (Start operation restricted mode information (INFO-DSLMTD))			
1981	07BDh	INFO action (I/O test mode information (INFO-IOTEST))			
1982	07BEh	INFO action (Configuration request information (INFO-CFG))			
1983	07BFh	INFO action (Reboot request information (INFO-RBT))			

8-12 I/O parameters

Parameter ID		Name	Setting range	Initial value	Update
Dec	Hex				
1792	0700h	STOP/STOP-COFF input action	0: Both are immediate 1: (STOP) Dec. & (STOP-COFF) Imm. 2: (STOP) Imm. & (STOP-COFF) Dec. 3: Both are deceleration	3	A
1793	0701h	FW-LS/RV-LS input action	-1: For homing sensor 0: Immediate stop 1: Deceleration stop 2: Immediate stop with alarm 3: Deceleration stop with alarm	2	A
1794	0702h	FW-BLK/RV-BLK input action	0: Immediate stop 1: Deceleration stop	1	A
1795	0703h	IN-POS positioning completion signal range	0 to 180 (1=0.1°)	18	A
1796	0704h	IN-POS positioning completion signal offset	-18 to 18 (1=0.1°)	0	A
1797	0705h	D-SEL drive start function	0: Without START-Func. (only select data) (Only operation data number selection) 1: With START-Func (Operation data number selection + START function)	1	A
1798	0706h	TEACH operation type setting	-1: Not set 1: Absolute positioning 8: Wrap absolute positioning	1	A
1799	0707h	ZSG signal width	1 to 1,800 (1=0.1°)	18	A
1800	0708h	RND-ZERO signal width	1 to 10,000 steps	10	A
1801	0709h	RND-ZERO signal source	0: Based on feedback position 1: Based on command position	0	A
1802	070Ah	MOVE minimum ON time	0 to 255 ms	0	A
1803	070Bh	PAUSE standby condition selection	0: Standstill mode (current cutback) 1: Operation mode (operating current is retained)	0	A
1805	070Dh	CRNT-LMT operating current limit value	0 to 1,000 (1=0.1 %)	500	A
1806	070Eh	SPD-LMT speed limit type selection	0: Ratio 1: Value	0	A
1807	070Fh	SPD-LMT speed limit ratio	1 to 100 %	50	A
1808	0710h	SPD-LMT speed limit value	1 to 4,000,000 Hz	1,000	A
1809	0711h	JOG-C time from JOG-P to JOG	1 to 5,000 (1=0.001 s)	500	B

Parameter ID		Name	Setting range	Initial value	Update
Dec	Hex				
1810	0712h	JOG-C time from JOG to JOG-H	1 to 5,000 (1=0.001 s)	1,000	B
1816	0718h	VA mode selection	0: Feedback speed attainment (speed at feedback position) 1: Speed at command position (only internal profile) 2: Speed at feedback position & command position (only internal profile)	0	B
1817	0719h	VA detection speed range	1 to 200 r/min	30	B
1818	071Ah	MAREA output source	0: Feedback position (ON after operation) 1: Command position (ON after operation) 2: Feedback position (MAREA output OFF at completion) 3: Command position (MAREA output OFF at completion)	0	A
1856	0740h	AREA0 positive direction position / offset	-2,147,483,648 to 2,147,483,647 steps	0	A
1857	0741h	AREA0 negative direction position / detection range			
1858	0742h	AREA1 positive direction position / offset			
1859	0743h	AREA1 negative direction position / detection range			
1860	0744h	AREA2 positive direction position / offset			
1861	0745h	AREA2 negative direction position / detection range			
1862	0746h	AREA3 positive direction position / offset			
1863	0747h	AREA3 negative direction position / detection range			
1864	0748h	AREA4 positive direction position / offset			
1865	0749h	AREA4 negative direction position / detection range			
1866	074Ah	AREA5 positive direction position / offset			
1867	074Bh	AREA5 negative direction position / detection range			
1868	074Ch	AREA6 positive direction position / offset			
1869	074Dh	AREA6 negative direction position / detection range			
1870	074Eh	AREA7 positive direction position / offset			
1871	074Fh	AREA7 negative direction position / detection range			
1872	0750h	AREA0 range setting mode	0: Range setting with absolute value 1: Offset/width setting from the target position	0	A
1873	0751h	AREA1 range setting mode			
1874	0752h	AREA2 range setting mode			
1875	0753h	AREA3 range setting mode			
1876	0754h	AREA4 range setting mode			
1877	0755h	AREA5 range setting mode			
1878	0756h	AREA6 range setting mode			
1879	0757h	AREA7 range setting mode			

Parameter ID		Name	Setting range	Initial value	Update
Dec	Hex				
1880	0758h	AREA0 positioning standard	0: Based on feedback position 1: Based on command position	0	A
1881	0759h	AREA1 positioning standard			
1882	075Ah	AREA2 positioning standard			
1883	075Bh	AREA3 positioning standard			
1884	075Ch	AREA4 positioning standard			
1885	075Dh	AREA5 positioning standard			
1886	075Eh	AREA6 positioning standard			
1887	075Fh	AREA7 positioning standard			
1888	0760h	D-SEL0 operation number selection	0 to 255: Operation data number	0	A
1889	0761h	D-SEL1 operation number selection		1	
1890	0762h	D-SEL2 operation number selection		2	
1891	0763h	D-SEL3 operation number selection		3	
1892	0764h	D-SEL4 operation number selection		4	
1893	0765h	D-SEL5 operation number selection		5	
1894	0766h	D-SEL6 operation number selection		6	
1895	0767h	D-SEL7 operation number selection		7	
1896	0768h	D-END0 operation number selection	0 to 255: Operation data number	0	A
1897	0769h	D-END1 operation number selection		1	
1898	076Ah	D-END2 operation number selection		2	
1899	076Bh	D-END3 operation number selection		3	
1900	076Ch	D-END4 operation number selection		4	
1901	076Dh	D-END5 operation number selection		5	
1902	076Eh	D-END6 operation number selection		6	
1903	076Fh	D-END7 operation number selection		7	
2554	09FAh	Current setting during motor standstill at T-MODE	0: Stop current 1: Operating current	0	A

8-13 Direct I/O setting parameters

Parameter ID		Name	Setting range	Initial value	Update
Dec	Hex				
2112	0840h	DIN0 input function	Input signals list ⇨ p.94	5: STOP	C
2113	0841h	DIN1 input function		1: FREE	
2128	0850h	DIN0 inverting mode	0: Not invert 1: Invert	0	C
2129	0851h	DIN1 inverting mode			
2176	0880h	DIN0 composite input function	Input signals list ⇨ p.94	0: Not used	C
2177	0881h	DIN1 composite input function			
2240	08C0h	DIN0 ON signal dead-time	0 to 250 ms	0	C
2241	08C1h	DIN1 ON signal dead-time			
2256	08D0h	DIN0 1 shot signal	0: The 1 shot signal function is disabled 1: The 1 shot signal function is enabled	0	C
2257	08D1h	DIN1 1 shot signal			

8-14 Remote I/O setting parameters

Parameter ID		Name	Setting range	Initial value	Update
Dec	Hex				
2304	0900h	R-IN0 input function	Input signals list ⇨ p.94	0: Not used	C
2305	0901h	R-IN1 input function			
2306	0902h	R-IN2 input function			
2307	0903h	R-IN3 input function			
2308	0904h	R-IN4 input function			
2309	0905h	R-IN5 input function			
2310	0906h	R-IN6 input function			
2311	0907h	R-IN7 input function			
2312	0908h	R-IN8 input function			
2313	0909h	R-IN9 input function			
2314	090Ah	R-IN10 input function			
2315	090Bh	R-IN11 input function			
2316	090Ch	R-IN12 input function			
2317	090Dh	R-IN13 input function			
2318	090Eh	R-IN14 input function			
2319	090Fh	R-IN15 input function			
2320	0910h	R-OUT0 output function	Output signals list ⇨ p.95	64: M0_R	C
2321	0911h	R-OUT1 output function		65: M1_R	
2322	0912h	R-OUT2 output function		66: M2_R	
2323	0913h	R-OUT3 output function		32: START_R	
2324	0914h	R-OUT4 output function		144: HOME-END	
2325	0915h	R-OUT5 output function		132: READY	
2326	0916h	R-OUT6 output function		135: INFO	
2327	0917h	R-OUT7 output function		129: ALM-A	
2328	0918h	R-OUT8 output function		136: SYS-BSY	
2329	0919h	R-OUT9 output function		160: AREA0	
2330	091Ah	R-OUT10 output function		161: AREA1	
2331	091Bh	R-OUT11 output function		162: AREA2	
2332	091Ch	R-OUT12 output function		157: TIM	

Parameter ID		Name	Setting range	Initial value	Update
Dec	Hex				
2333	091Dh	R-OUT13 output function	Output signals list ⇨ p.95	134: MOVE	C
2334	091Eh	R-OUT14 output function		138: IN-POS	
2335	091Fh	R-OUT15 output function		140: TLC	
2352	0930h	R-OUT0 OFF delay time	0 to 250 ms	0	C
2353	0931h	R-OUT1 OFF delay time			
2354	0932h	R-OUT2 OFF delay time			
2355	0933h	R-OUT3 OFF delay time			
2356	0934h	R-OUT4 OFF delay time			
2357	0935h	R-OUT5 OFF delay time			
2358	0936h	R-OUT6 OFF delay time			
2359	0937h	R-OUT7 OFF delay time			
2360	0938h	R-OUT8 OFF delay time			
2361	0939h	R-OUT9 OFF delay time			
2362	093Ah	R-OUT10 OFF delay time			
2363	093Bh	R-OUT11 OFF delay time			
2364	093Ch	R-OUT12 OFF delay time			
2365	093Dh	R-OUT13 OFF delay time			
2366	093Eh	R-OUT14 OFF delay time			
2367	093Fh	R-OUT15 OFF delay time			

8-15 Virtual input parameters

Parameter ID		Name	Setting range	Initial value	Update
Dec	Hex				
2368	0940h	Virtual input (VIR-IN0) function	Input signals list ⇨ p.94	0: Not used	C
2369	0941h	Virtual input (VIR-IN1) function			
2370	0942h	Virtual input (VIR-IN2) function			
2371	0943h	Virtual input (VIR-IN3) function			
2372	0944h	Virtual input (VIR-IN0) source selection	Output signals list ⇨ p.95	128: CONST-OFF	C
2373	0945h	Virtual input (VIR-IN1) source selection			
2374	0946h	Virtual input (VIR-IN2) source selection			
2375	0947h	Virtual input (VIR-IN3) source selection	0: Not invert 1: Invert	0	C
2376	0948h	Virtual input (VIR-IN0) inverting mode			
2377	0949h	Virtual input (VIR-IN1) inverting mode			
2378	094Ah	Virtual input (VIR-IN2) inverting mode	0 to 250 ms	0	C
2379	094Bh	Virtual input (VIR-IN3) inverting mode			
2380	094Ch	Virtual input (VIR-IN0) ON signal dead time			
2381	094Dh	Virtual input (VIR-IN1) ON signal dead time			
2382	094Eh	Virtual input (VIR-IN2) ON signal dead time	0: The 1 shot signal function is disabled 1: The 1 shot signal function is enabled	0	C
2383	094Fh	Virtual input (VIR-IN3) ON signal dead time			
2384	0950h	Virtual input (VIR-IN0) 1 shot signal mode			
2385	0951h	Virtual input (VIR-IN1) 1 shot signal mode			
2386	0952h	Virtual input (VIR-IN2) 1 shot signal mode	0: The 1 shot signal function is disabled 1: The 1 shot signal function is enabled	0	C
2387	0953h	Virtual input (VIR-IN3) 1 shot signal mode			

8-16 User output setting parameters

Parameter ID		Name	Setting range	Initial value	Update
Dec	Hex				
2400	0960h	User output (USR-OUT0) source A function	Output signals list ⇒ p.95	128: CONST-OFF	C
2401	0961h	User output (USR-OUT1) source A function			
2402	0962h	User output (USR-OUT0) source A inverting mode	0: Not invert 1: Invert	0	C
2403	0963h	User output (USR-OUT1) source A inverting mode			
2404	0964h	User output (USR-OUT0) source B function	Output signals list ⇒ p.95	128: CONST-OFF	C
2405	0965h	User output (USR-OUT1) source B function			
2406	0966h	User output (USR-OUT0) source B inverting mode	0: Not invert 1: Invert	0	C
2407	0967h	User output (USR-OUT1) source B inverting mode			
2408	0968h	User output (USR-OUT0) logical operation	0: AND 1: OR	1	C
2409	0969h	User output (USR-OUT1) logical operation			

8-17 Driver mode setting parameters

Parameter ID		Name	Setting range	Initial value	Update
Dec	Hex				
498	01F2h	USB-ID enable	0: Disable 1: Enable	1	D
499	01F3h	USB-ID	0 to 999,999,999	0	D
2555	09FBh	USB-PID	0 to 31	0	D

8-18 Assignable monitor setting parameters

Parameter ID		Name	Description	Setting range	Initial value	Update
Dec	Hex					
25600	6400h	Assignable monitor address 0	Sets the parameter ID to show on the assignable monitor.	Set from items of "3 Monitor commands" on p.69	124: Driver temperature	A
25601	6401h	Assignable monitor address 1			125: Motor temperature	
25602	6402h	Assignable monitor address 2			109: Cumulative load monitor	
25603	6403h	Assignable monitor address 3			127: Tripmeter	

9 I/O signals assignment list

To assign signals via industrial network, use the "assignment numbers" in the table instead of the signal names.

9-1 Input signals

Assignment number	Signal name	Assignment number	Signal name	Assignment number	Signal name
0	Not used	35	NEXT	65	M1
1	FREE	36	HOME	66	M2
2	C-ON	37	ZHOME	67	M3
3	CLR	40	D-SEL0	68	M4
4	STOP-COFF	41	D-SEL1	69	M5
5	STOP	42	D-SEL2	70	M6
6	PAUSE	43	D-SEL3	71	M7
7	BREAK-ATSQ	44	D-SEL4	75	TEACH
8	ALM-RST	45	D-SEL5	80	R0
9	P-PRESET	46	D-SEL6	81	R1
10	EL-PRST	47	D-SEL7	82	R2
13	LAT-CLR	48	FW-JOG	83	R3
14	INFO-CLR	49	RV-JOG	84	R4
16	HMI	50	FW-JOG-H	85	R5
18	CCM	51	RV-JOG-H	86	R6
21	T-MODE	52	FW-JOG-P	87	R7
22	CRNT-LMT	53	RV-JOG-P	88	R8
23	SPD-LMT	54	FW-JOG-C	89	R9
26	FW-BLK	55	RV-JOG-C	90	R10
27	RV-BLK	56	FW-POS	91	R11
28	FW-LS	57	RV-POS	92	R12
29	RV-LS	58	FW-SPD	93	R13
30	HOMES	59	RV-SPD	94	R14
31	SLIT	60	FW-PSH	95	R15
32	START	61	RV-PSH		
33	SSTART	64	M0		

9-2 Output signals

Assignment number	Signal name	Assignment number	Signal name	Assignment number	Signal name
0	Not used	56	FW-POS_R	145	ABSPEN
1	FREE_R	57	RV-POS_R	146	ELPRST-MON
2	C-ON_R	58	FW-SPD_R	149	PRST-DIS
3	CLR_R	59	RV-SPD_R	150	PRST-STLD
4	STOP-COFF_R	60	FW-PSH_R	151	ORGN-STLD
5	STOP_R	61	RV-PSH_R	152	RND-OVF
6	PAUSE_R	64	M0_R	153	FW-SLS
7	BREAK-ATSQ_R	65	M1_R	154	RV-SLS
8	ALM-RST_R	66	M2_R	155	ZSG
9	P-PRESET_R	67	M3_R	156	RND-ZERO
10	EL-PRST_R	68	M4_R	157	TIM
13	LAT-CLR_R	69	M5_R	159	MAREA
14	INFO-CLR_R	70	M6_R	160	AREA0
16	HMI_R	71	M7_R	161	AREA1
18	CCM_R	75	TEACH_R	162	AREA2
21	T-MODE_R	80	R0_R	163	AREA3
22	CRNT-LMT_R	81	R1_R	164	AREA4
23	SPD-LMT_R	82	R2_R	165	AREA5
26	FW-BLK_R	83	R3_R	166	AREA6
27	RV-BLK_R	84	R4_R	167	AREA7
28	FW-LS_R	85	R5_R	168	MPS
29	RV-LS_R	86	R6_R	169	MBC
30	HOMES_R	87	R7_R	180	USR-OUT0
31	SLIT_R	88	R8_R	181	USR-OUT1
32	START_R	89	R9_R	192	CRNT-LMTD
33	SSTART_R	90	R10_R	193	SPD-LMTD
35	NEXT_R	91	R11_R	196	OPE-BSY
36	HOME_R	92	R12_R	197	PAUSE-BSY
37	ZHOME_R	93	R13_R	198	SEQ-BSY
40	D-SEL0_R	94	R14_R	199	DELAY-BSY
41	D-SEL1_R	95	R15_R	200	JUMPO-LAT
42	D-SEL2_R	128	CONST-OFF	201	JUMP1-LAT
43	D-SEL3_R	129	ALM-A	202	NEXT-LAT
44	D-SEL4_R	130	ALM-B	204	DCMD-RDY
45	D-SEL5_R	131	SYS-RDY	205	DCMD-FULL
46	D-SEL6_R	132	READY	207	M-CHG
47	D-SEL7_R	134	MOVE	208	M-ACT0
48	FW-JOG_R	135	INFO	209	M-ACT1
49	RV-JOG_R	136	SYS-BSY	210	M-ACT2
50	FW-JOG-H_R	138	IN-POS	211	M-ACT3
51	RV-JOG-H_R	140	TLC	212	M-ACT4
52	FW-JOG-P_R	141	VA	213	M-ACT5
53	RV-JOG-P_R	142	CRNT	214	M-ACT6
54	FW-JOG-C_R	143	AUTO-CD	215	M-ACT7
55	RV-JOG-C_R	144	HOME-END	216	D-END0

I/O signals assignment list

Assignment number	Signal name	Assignment number	Signal name
217	D-END1	233	INFO-START
218	D-END2	234	INFO-ZHOME
219	D-END3	235	INFO-PR-REQ
220	D-END4	237	INFO-EGR-E
221	D-END5	238	INFO-RND-E
222	D-END6	240	INFO-FW-OT
223	D-END7	241	INFO-RV-OT
224	INFO-USRIO	242	INFO-CULD0
225	INFO-POSERR	243	INFO-CULD1
226	INFO-DRVTMP	244	INFO-TRIP
227	INFO-MTRTMP	245	INFO-ODO
228	INFO-OVOLT	252	INFO-DSLMTD
229	INFO-UVOLT	253	INFO-IOTEST
230	INFO-OLTIME	254	INFO-CFG
232	INFO-SPD	255	INFO-RBT

5 Troubleshooting

This part explains alarm and information functions.

◆ Table of contents

1	Detection of communication errors ..	98
1-1	Communication timeout	98
1-2	Error of communication settings	98
2	Alarms.....	99
2-1	Alarm reset.....	99
2-2	Alarm history	99
2-3	Generation condition of alarms	99
2-4	Alarm list.....	100
2-5	Timing chart	105
3	Information.....	107
3-1	Information history.....	110
3-2	Information list	110
4	Troubleshooting and remedial actions	113

1 Detection of communication errors

This chapter explains functions to detect that an error occurred in PROFINET.

1-1 Communication timeout

If communication is interrupted due to disconnection of the PROFINET cable or other reasons, the communication timeout is detected.

When the communication timeout is detected, the NS LED on the driver blinks in red.

When connection is established with the host controller again, the communication timeout is automatically cleared, and the NS LED on the driver is lit in green.

If the communication timeout is detected, check the following points.

- Is the PROFINET cable disconnected?
- Is the power supply for the host controller turned on?

1-2 Error of communication settings

If the communication settings of PROFINET have not been made or the stored communication setting data is damaged, an error of communication settings is detected.

When an error of communication settings is detected, the MS LED on the driver blinks in green or red. Refer to the table for details.

If the reset method in the table is performed and the communication settings are completed, the MS LED on the driver is lit in green.

Description of error	MS LED status	How to reset
The communication settings have not been made in the driver.	Blinking green	Make the communication settings using the Configuration tool of the host controller.
The data for the communication settings stored in the driver is damaged.	Blinking red	Execute either of the following, and turn off the main power supply and the control power supply and on again. After that, make the communication settings again using the Configuration tool of the host controller. <ul style="list-style-type: none"> • Initialize the communication settings using the Configuration tool of the host controller. (Only the communication settings can be initialized.) • Execute [Restore to factory settings (including communication settings)] under the [Communication] menu with the MEXE02 software. (All parameters including the communication settings are initialized.)

2 Alarms

This driver has the alarm function to protect from temperature rise, poor connection, error in operation, and the like. If an alarm is generated, the ALM-A output is turned ON and the ALM-B output is turned OFF to stop the motor. At the same time, the PWR/ALM LED blinks in red.

Details of the alarm being generated can be checked by counting the number of times the PWR/ALM LED blinks, or using PROFINET or the **MEXE02** software.

2-1 Alarm reset

Before resetting an alarm, always remove the cause of the alarm and ensure safety, and perform one of the reset operations specified below.

- Turn the ALM-RST input ON. (It is enabled at the ON edge.)
- Execute the alarm reset by the maintenance command via PROFINET.
- Execute the alarm reset using the **MEXE02** software.
- Turn off the main power supply and the control power supply, and on again.



- Some alarms cannot be reset by other methods than turning on the main power supply and control power supply again. Refer to "2-4 Alarm list" on p.100.
- An alarm of the absolute position error can be reset if the position preset or return-to-home operation is performed. If it cannot be reset by these methods, the ABZO sensor may be damaged.

2-2 Alarm history

Up to 10 generated alarm items are stored in the non-volatile memory in order of the latest to the oldest. The alarm history stored in the non-volatile memory can be read or cleared if one of the following reset operations is performed.

- Read the alarm history by the monitor command via PROFINET.
- Clear the alarm history by the maintenance command via PROFINET.
- Read or clear the alarm history using the **MEXE02** software.

2-3 Generation condition of alarms

Alarms shown in the table will be generated if the generation condition is exceeded.

Alarm code	Alarm name	Motor model	Generation condition
21h	Main circuit overheat	–	85 °C (185 °F)
22h	Overvoltage	–	36 V *1 63 V *2
26h	Motor overheat	–	85 °C (185 °F)
31h	Overspeed	AZM14, AZM15, AZM24, AZM26	8,000 r/min
		AZM46, AZM48, AZM66	4,500 r/min
		AZM69	2,500 r/min
34h	Command pulse error	–	38,400 r/min

*1 When the Main power mode is 24 VDC.

*2 When the Main power mode is 48 VDC.

2-4 Alarm list

Alarm code	Number of times LED blinks	Alarm type	Cause	Remedial action	How to reset	Motor excitation *
10h	4	Excessive position deviation	<ul style="list-style-type: none"> When the motor was in a state of current ON, the deviation between the command position and the feedback position exceeded the value set in the "Excessive position deviation alarm" parameter in the motor shaft. A load is large, or the acceleration/deceleration time or the acceleration/deceleration rate is too short against the load. The operating range of positioning push-motion SD operation was exceeded. 	<ul style="list-style-type: none"> Decrease a load. Increase the acceleration/deceleration time or slow the acceleration/deceleration rate. increase the operating current. Reconsider the operation data. 	Any of reset operations	Non-excitation
20h	5	Overcurrent	The motor, the cable, and the driver output circuit were short-circuited.	Turn off the main power supply and the control power supply first, and check that the motor, the cable, and the driver are not damaged. After that, turn on the main power supply and the control power supply again. If the alarm is still not reset, the motor, the cable, or the driver may be damaged. Contact your nearest Oriental Motor sales office.	Turn on the main power supply and control power supply again	Non-excitation
21h	2	Main circuit overheat	The internal temperature of the driver reached the upper limit of the specification value.	Reconsider the ventilation condition.	Any of reset operations	Non-excitation
22h	3	Overvoltage	<ul style="list-style-type: none"> The main power supply voltage exceeded the permissible value. A large load inertia was suddenly stopped. Vertical operation (elevating operation) was performed. 	<ul style="list-style-type: none"> Check the input voltage of the main power supply. Decrease a load. Increase the acceleration/deceleration time or slow the acceleration/deceleration rate. 	Any of reset operations	Non-excitation
23h	3	Main power supply OFF	The main power supply was shut off during operation.	Check if the main power supply is properly supplied.	Any of reset operations	Non-excitation
25h	3	Undervoltage	The main power supply was shut off momentarily or a voltage was insufficient.	Check the input voltage of the main power supply.	Any of reset operations	Non-excitation
26h	8	Motor overheat	The detection temperature of the ABZO sensor reached the upper limit of the specification value.	<ul style="list-style-type: none"> Check the heat radiation condition of the motor. Reconsider the ventilation condition. 	Any of reset operations	Non-excitation
28h	8	Sensor error	An error of the ABZO sensor was detected during operation.	Turn off the main power supply and the control power supply, and check the connection of the motor. After that, turn on the main power supply and the control power supply again.	Turn on the main power supply and control power supply again	Non-excitation

Alarm code	Number of times LED blinks	Alarm type	Cause	Remedial action	How to reset	Motor excitation *
29h	9	CPU peripheral circuit error	<ul style="list-style-type: none"> • A temperature significantly higher or lower than the specifications was detected. • The driver internal circuit was damaged. 	<ul style="list-style-type: none"> • Reconsider the ambient temperature and ventilation condition. • Turn off the main power supply and the control power supply, and check if the driver is damaged. After that, turn on the main power supply and the control power supply again. If the alarm has still not reset, the driver may be damaged. Contact your nearest Oriental Motor sales office. 	Turn on the main power supply and control power supply again	Non-excitation
2Ah	8	ABZO sensor communication error	An error was detected in communication between the driver and the ABZO sensor.	Turn off the main power supply and the control power supply, and check the connection of the ABZO sensor. After that, turn on the main power supply and the control power supply again.	Turn on the main power supply and control power supply again	Non-excitation
30h	2	Overload	A load exceeding the maximum torque was applied for the time exceeded the value set in the "Overload alarm" parameter.	<ul style="list-style-type: none"> • Decrease a load. • Increase the acceleration/ deceleration time or slow the acceleration/ deceleration rate. • Increase the operating current. 	Any of reset operations	Non-excitation
31h	2	Overspeed	The feedback speed of the motor output shaft exceeded the specification value.	<ul style="list-style-type: none"> • Reconsider the "Electronic gear A" parameter and the "Electronic gear B" parameter, and set the speed of the motor output shaft to less than the specification value. • If an overshoot is occurred at the time of accelerating, increase the acceleration time or slow the acceleration rate. 	Any of reset operations	Non-excitation
33h	7	Absolute position error	The home information of the ABZO sensor was damaged.	Perform the position preset or return-to-home operation to set the home again.	Turn on the main power supply and control power supply again	Non-excitation
34h	2	Command pulse error	The command pulse frequency exceeded the specification value.	Decrease the frequency of the command pulse.	Any of reset operations	Non-excitation
41h	9	EEPROM error	The data stored in the driver was damaged.	Initialize all parameters.	Turn on the main power supply and control power supply again	Non-excitation
42h	8	Sensor error at power-on	An error of the ABZO sensor was detected when the control power supply was turned on.	Turn off the main power supply and the control power supply, and check the connection of the ABZO sensor. After that, turn on the main power supply and the control power supply again.	Turn on the main power supply and control power supply again	Non-excitation

Alarm code	Number of times LED blinks	Alarm type	Cause	Remedial action	How to reset	Motor excitation *
43h	8	Rotation error at power on	The motor was being rotated when the control power supply was turned on.	Reconsider the load conditions so that the motor output shaft does not rotate by an external force when the control power supply is turned on.	Turn on the main power supply and control power supply again	Non-excitation
44h	8	Encoder EEPROM error	The data stored in the ABZO sensor was damaged.	Execute either of the following operations. If the same alarm is still generated, the ABZO sensor has been damaged. Contact your nearest Oriental Motor sales office. <ul style="list-style-type: none"> • Set phase Z again with the "ZSG-PRESET" of the maintenance command. • Execute the "Clear tripmeter" of the maintenance command. 	Turn on the main power supply and control power supply again	Non-excitation
45h	8	Motor combination error	A motor not allowed to combine with the driver was connected. (⇒ Refer to p.104 for details.)	Check the motor model name and the driver model name, and connect them in the correct combination.	Turn on the main power supply and control power supply again	Non-excitation
4Ah	7	Return-to-home incomplete	Absolute positioning operation was started in a state where the coordinates had not been set.	Execute the position preset or return-to-home operation.	Any of reset operations	Excitation
60h	7	±LS both sides active	<ul style="list-style-type: none"> • When the "FW-LS/RV-LS input action" parameter is set to "2: Immediate stop with alarm" or "3: Deceleration stop with alarm," both the FW-LS input and the RV-LS input were detected. • Return-to-home operation was executed in a state where both the FW-LS input and RV-LS input were detected. 	Check the sensor logic installed and the "Inverting mode" parameter.	Any of reset operations	Excitation
61h	7	Reverse ±LS connection	The LS input opposite to the operating direction was detected while return-to-home operation in the 2-sensor mode or the 3-sensor mode was performed.	Check the wiring of the sensor.	Any of reset operations	Excitation
62h	7	Return-to-home operation error	<ul style="list-style-type: none"> • An unanticipated load was applied while return-to-home operation was performed. • The installation positions of the FW-LS and RV-LS sensors and the HOME sensor are near to each other. • Position preset processing upon completion of return-to-home operation was failed. • In return-to-home operation in the one-way rotation mode, the HOME sensor was exceeded while the motor decelerated to a stop. 	<ul style="list-style-type: none"> • Check the load. • Reconsider the sensor installation positions and the starting direction of motor operation. • See that a load exceeding the maximum torque is not applied upon completion of return-to-home operation. • Reconsider the specifications of the HOME sensor and the "(HOME) Acceleration/deceleration" parameter. 	Any of reset operations	Excitation

Alarm code	Number of times LED blinks	Alarm type	Cause	Remedial action	How to reset	Motor excitation *
63h	7	No HOMES	The HOMES input was not detected at a position between the FW-LS input and the RV-LS input while return-to-home operation in the 3-sensor mode was performed.	Install the HOME sensor at a position between the FW-LS and RV-LS sensors.	Any of reset operations	Excitation
64h	7	TIM, ZSG, SLIT signal error	None of the TIM output, the ZSG output, or the SLIT input could be detected during return-to-home operation.	<ul style="list-style-type: none"> Reconsider the connection status of the load and the position of the HOME sensor so that these signals should be ON while the HOMES input is ON. When a signal is not used, set the "(HOME) TIM/ZSG signal detection" parameter or the "(HOME) SLIT detection" parameter to "0: Disable." 	Any of reset operations	Excitation
66h	7	Hardware overtravel	When the "FW-LS/RV-LS input action" parameter is set to "2: Immediate stop with alarm" or "3: Deceleration stop with alarm," the FW-LS input or the RV-LS input was detected.	Reset the alarm and then escape from the sensor by operating the motor or manually.	Any of reset operations	Excitation
67h	7	Software overtravel	When the "Software overtravel" parameter is set to "2: Immediate stop with alarm" or "3: Deceleration stop with alarm," the motor position reached the set value of the software limit.	<ul style="list-style-type: none"> Reconsider the operation data. Reset the alarm and then escape from the sensor by operating the motor or manually. 	Any of reset operations	Excitation
6Ah	7	Return-to-home operation offset error	When offset movement as part of return-to-home operation was performed, the FW-LS input or the RV-LS input was detected.	Check the offset value.	Any of reset operations	Excitation
6Dh	7	Mechanical overtravel	The product having set the home reached the mechanism limit stored in the ABZO sensor.	<ul style="list-style-type: none"> Check the travel amount (position). Reset the alarm and then escape from the sensor by operating the motor or manually. 	Any of reset operations	Excitation
70h	7	Operation data error	<ul style="list-style-type: none"> Stored data operation was performed with data whose operating speed was 0. Operation was performed at the operating speed or operating current exceeding the value set in the "Mechanism protection parameter." Wrap operation was executed when wrap setting was disabled. Push-motion operation or push-motion return-to-home operation was performed with the DGII Series. 	<ul style="list-style-type: none"> Check the operation data. Check the value set in the "Mechanism protection parameter" using the unit information monitor of the MEXE02 software. Check the wrap setting. Push-motion operation as well as push-motion return-to-home operation cannot be performed with the DGII Series. 	Any of reset operations	Excitation
71h	7	Electronic gear setting error	The resolution set with the "Electronic gear A" parameter and the "Electronic gear B" parameter was out of the specification.	Reconsider the "Electronic gear A" parameter and the "Electronic gear B" parameter, and set the resolution in a range of the specification.	Turn on the main power supply and control power supply again	Non-excitation

Alarm code	Number of times LED blinks	Alarm type	Cause	Remedial action	How to reset	Motor excitation *
72h	7	Wrap setting error	The control power supply was turned on in a state where a value of the resolution and that of the "Initial coordinate generation & wrap setting range" parameter were inconsistent.	Set the "Initial coordinate generation & wrap setting range" parameter properly, and turn on the main power supply and the control power supply again.	Turn on the main power supply and control power supply again	Non-excitation
81h	7	Network bus error	Communication with the host controller was disconnected during operation.	Check the connection with the host controller and the condition of the power supply of the host controller.	Any of reset operations	Excitation
82h	7	Network module error	An error was detected in the network module.	Turn on the main power supply and the control power supply again.	Turn on the main power supply and control power supply again	Non-excitation
F0h	Light	CPU error	CPU malfunctioned.	Turn on the main power supply and the control power supply again.	Turn on the main power supply and control power supply again	Non-excitation

* An excitation state of the motor when an alarm is generated is as follows.

Non-excitation: If an alarm is generated, the motor current is cut off and the motor holding force is lost.

When an electromagnetic brake motor is used, the electromagnetic brake is in a state of holding the motor shaft.

Excitation: Even if an alarm is generated, the motor current is not cut off and the motor position is held.

Related parameters

Parameter ID		Parameter name	Description	Initial value
Dec	Hex			
384	0180h	Overload alarm	Sets the condition in which the overload alarm is generated. [Setting range] 1 to 300 (1=0.1 s)	50
385	0181h	Excessive position deviation alarm	Sets the condition in which the excessive position deviation alarm is generated. [Setting range] 1 to 30,000 (1=0.01 rev)	300
24968	6188h	Network bus error alarm	Sets the function of the network bus error alarm. [Setting range] 0: Disable 1: Enable	1

■ About causes of the motor combination error (alarm code 45h)

An alarm of the motor combination error is generated in the following conditions.

- When a motor for the AC power supply was connected to the driver.
- When a motor of frame size 20 mm (0.79 in.) or 28 mm (1.10 in.) was connected to the driver and 48 VDC was applied.

2-5 Timing chart

■ When the motor remains in an excitation state even if an alarm is generated

1. If an error occurs, the ALM-B output and the MOVE output are turned OFF. At the same time, the motor stops immediately.
2. When resetting the alarm, turn the operation command OFF. If the alarm is reset while the operation command is in an ON state, the motor may start suddenly, causing injury or damage to equipment.
3. Remove the cause of the alarm before turning the ALM-RST input ON. The alarm is reset, and the ALM-B output and the READY output are turned ON.
4. Check the ALM-B output has been turned ON and then turn the ALM-RST input OFF.

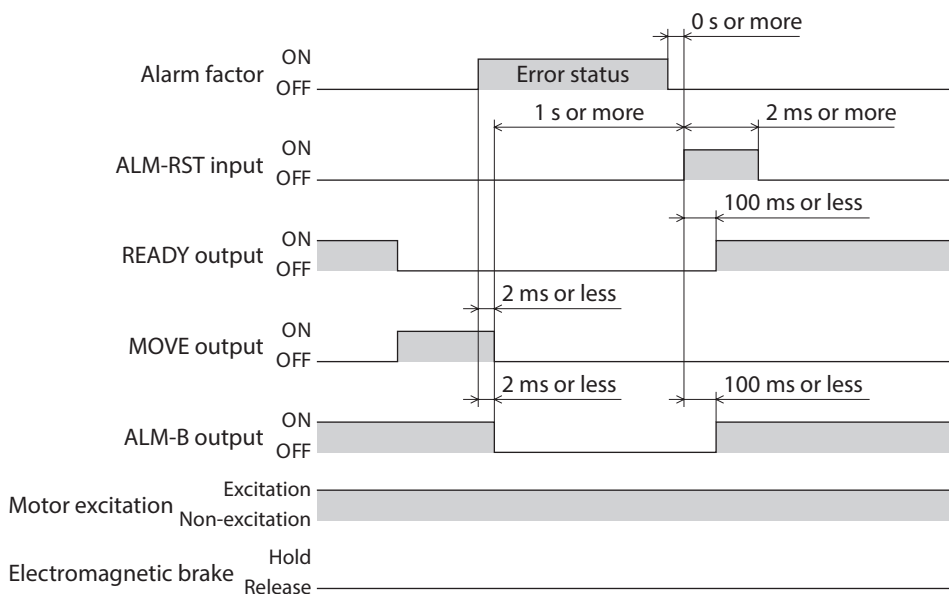
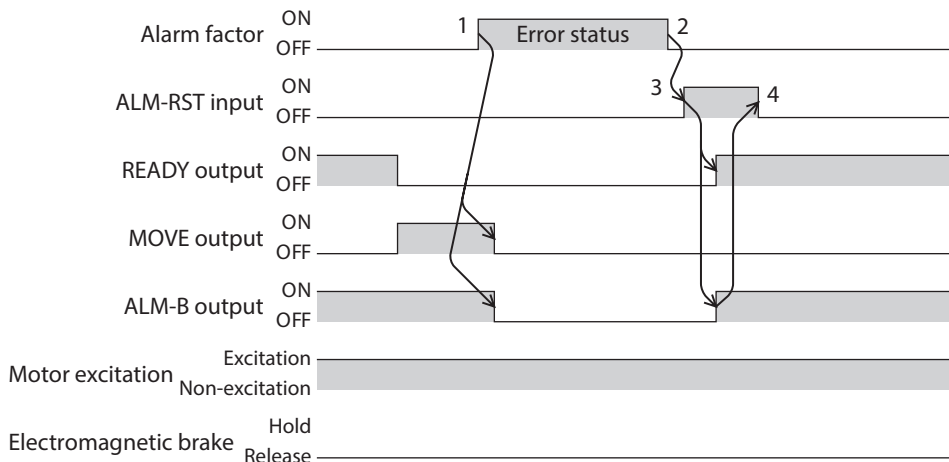

■ When the motor puts into a non-excitation state if an alarm is generated

1. If an error occurs, the ALM-B output and the MOVE output are turned OFF. At the same time, the motor stops immediately.
2. When resetting the alarm, turn the operation command OFF. If the alarm is reset while the operation command is in an ON state, the motor may start suddenly, causing injury or damage to equipment.
3. Remove the cause of the alarm before turning the ALM-RST input ON. The alarm is reset, and the ALM-B output and the READY output are turned ON.
4. Check the ALM-B output has been turned ON and then turn the ALM-RST input OFF.

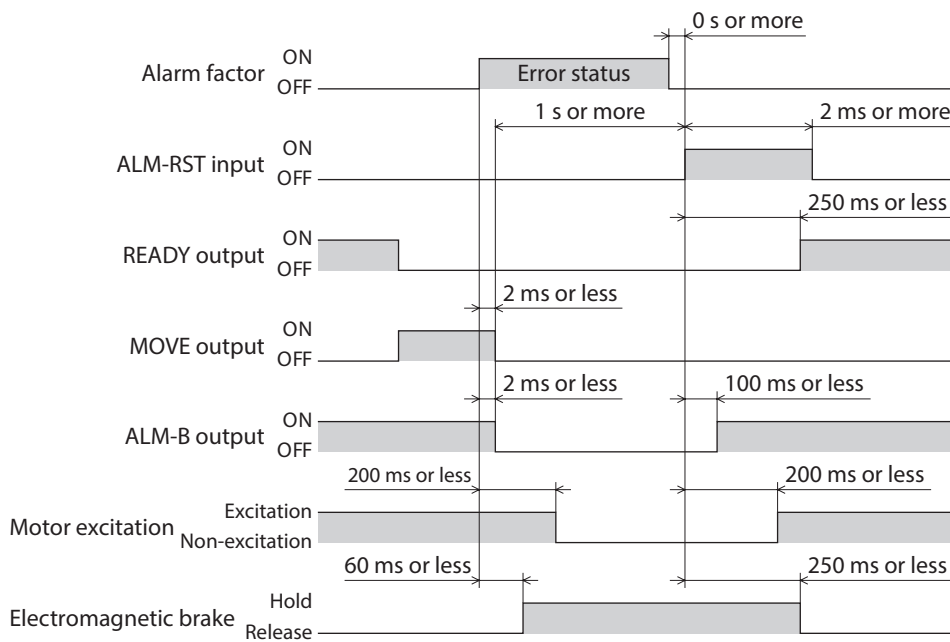
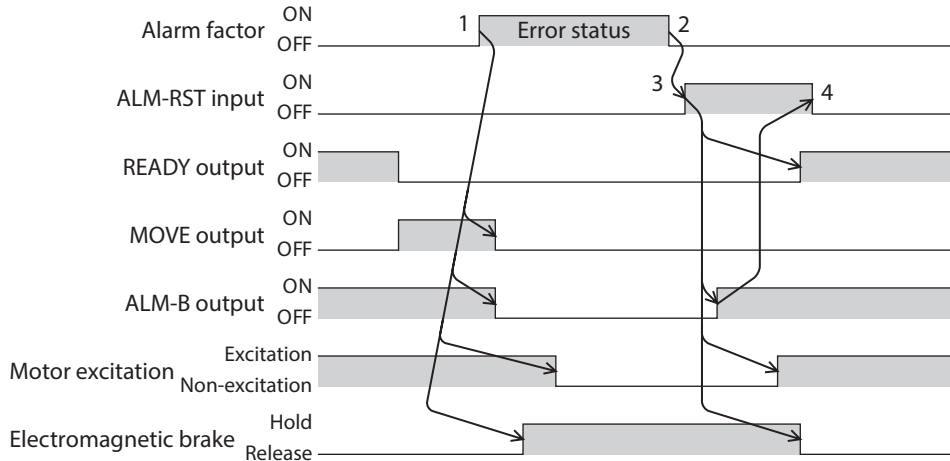

3 Information

The driver is equipped with a function to generate information output before an alarm is generated. This function can be utilized for periodic maintenance of equipment by setting a suitable value in the parameter of each information.

For example, utilizing the "Motor temperature information" parameter can prevent equipment malfunction or production stoppage due to motor overheat. In addition, the "Tripmeter information" parameter can be utilized as a reference to do maintenances every time a certain travel distance is reached.

■ Status when information is generated

● Information bit output

If information is generated, a bit output (INFO-** output) of the corresponding information is turned ON.

A desired output signal can be assigned to the INFO-USRIO output among bit outputs and used. If the assigned output signal is turned ON, the INFO-USRIO output is also turned ON. (Details of bit output → p.110)

● INFO output

If information is generated, the INFO output is turned ON.

● LED indicator

If information is generated, the PWR/ALM LED blinks in blue.

● Operation of motor

The motor continues to operate during information unlike in the case of an alarm.

● Parameter

Each information has a corresponding "INFO action" parameter. If the parameter is set to "0: No Info reflect," only the bit output of information is turned ON, and the INFO output and LED are not changed.

Related parameters

Parameter ID		Parameter name	Description	Initial value
Dec	Hex			
416	01A0h	Driver temperature information (INFO-DRVTMP)	Sets the condition in which the driver temperature information (INFO-DRVTMP) is generated. [Setting range] 40 to 85 °C	85
417	01A1h	Overload time information (INFO-OLTIME)	Sets the condition in which the overload time information (INFO-OLTIME) is generated. [Setting range] 1 to 300 (1=0.1 s)	50
418	01A2h	Speed information (INFO-SPD)	Sets the condition in which the speed information (INFO-SPD) is generated. [Setting range] 0: Disable 1 to 12,000 r/min	0
421	01A5h	Position deviation information (INFO-POSERR)	Sets the condition in which the position deviation information (INFO-POSERR) is generated. [Setting range] 1 to 30,000 (1=0.01 rev)	300
424	01A8h	Motor temperature information (INFO-MTRTMP)	Sets the condition in which the motor temperature information (INFO-MTRTMP) is generated. [Setting range] 40 to 120 °C	85
427	01ABh	Overvoltage information (INFO-OVOLT)	Sets the condition in which the overvoltage information (INFO-OVOLT) is generated. [Setting range] 140 to 630 (1=0.1 V)	630

Parameter ID		Parameter name	Description	Initial value
Dec	Hex			
428	01ACh	Undervoltage information (INFO-UVOLT)	Sets the condition in which the undervoltage information (INFO-UVOLT) is generated. [Setting range] 140 to 630 (1=0.1 V)	140
431	01AFh	Tripmeter information (INFO-TRIP)	Sets the condition in which the tripmeter information (INFO-TRIP) is generated. [Setting range] 0: Disable 1 to 2,147,483,647 (1=0.1 kRev)	0
432	01B0h	Odometer information (INFO-ODO)	Sets the condition in which the odometer information (INFO-ODO) is generated. [Setting range] 0: Disable 1 to 2,147,483,647 (1=0.1 kRev)	0
433	01B1h	Cumulative load 0 information (INFO-CULD0)	Sets the condition in which the cumulative load 0 information (INFO-CULD0) is generated. [Setting range] 0 to 2,147,483,647	0
434	01B2h	Cumulative load 1 information (INFO-CULD1)	Sets the condition in which the cumulative load 1 information (INFO-CULD1) is generated. [Setting range] 0 to 2,147,483,647	0
435	01B3h	Cumulative load value auto clear	Clears the cumulative load when operation is started (at the ON edge of the MOVE output). [Setting range] 0: Disable 1: Enable	1
436	01B4h	Cumulative load value count divisor	Sets the divisor of the cumulative load. [Setting range] 1 to 32,767	1
444	01BCh	INFO-USRIO output selection	Selects the output signal to be checked by the INFO-USRIO output. [Setting range] Output signal ⇨ p.95	128: CONST-OFF
445	01BDh	INFO-USRIO output inversion	Sets the output logic of the INFO-USRIO output. [Setting range] 0: Not invert 1: Invert	0
446	01BEh	Information LED condition	Sets the LED status when information is generated. [Setting range] 0: Disable (LED does not blink) 1: Enable (LED blinks)	1
447	01BFh	Information auto clear	When the cause of information is eliminated, the INFO output and the bit output of the corresponding information are turned OFF automatically. [Setting range] 0: Disable (not turned OFF automatically) 1: Enable (turned OFF automatically)	1

Parameter ID		Parameter name	Description	Initial value
Dec	Hex			
1952	07A0h	INFO action (Assigned I/O status information (INFO-USRIO))	Sets the bit output, the INFO output, and the LED status when information is generated. [Setting range] 0: No info reflect (Only the bit output is ON.) 1: Info reflect (The bit output and the INFO output are ON and the LED blinks.)	1
1953	07A1h	INFO action (Position deviation information (INFO-POSERR))		
1954	07A2h	INFO action (Driver temperature information (INFO-DRVTMP))		
1955	07A3h	INFO action (Motor temperature information (INFO-MTRTMP))		
1956	07A4h	INFO action (Overvoltage information (INFO-OVOLT))		
1957	07A5h	INFO action (Undervoltage information (INFO-UVOLT))		
1958	07A6h	INFO action (Overload time information (INFO-OLTIME))		
1960	07A8h	INFO action (Speed information (INFO-SPD))		
1961	07A9h	INFO action (Start operation error information (INFO-START))		
1962	07AAh	INFO action (Start ZHOME error information (INFO-ZHOME))		
1963	07ABh	INFO action (PRESET request information (INFO-PR-REQ))		
1965	07ADh	INFO action (Electronic gear setting error information (INFO-EGR-E))		
1966	07AEh	INFO action (Wrap setting error information (INFO-RND-E))		
1968	07B0h	INFO action (Forward operation prohibition information (INFO-FW-OT))		
1969	07B1h	INFO action (Reverse operation prohibition information (INFO-RV-OT))		
1970	07B2h	INFO action (Cumulative load 0 information (INFO-CULD0))		
1971	07B3h	INFO action (Cumulative load 1 information (INFO-CULD1))		
1972	07B4h	INFO action (Tripmeter information (INFO-TRIP))		
1973	07B5h	INFO action (Odometer information (INFO-ODO))		
1980	07BCh	INFO action (Start operation restricted mode information (INFO-DSLMTD))		
1981	07BDh	INFO action (I/O test mode information (INFO-IOTEST))		
1982	07BEh	INFO action (Configuration request information (INFO-CFG))		
1983	07BFh	INFO action (Reboot request information (INFO-RBT))		

3-1 Information history

Up to 16 generated information items are stored in the RAM in order of the latest to the oldest. Information items stored as the information history are the information code, generation time, and contents of information. The information history stored in the RAM can be read or cleared if one of the following is performed.

- Read the information history with the monitor command via PROFINET.
- Clear the information history with the maintenance command via PROFINET.
- Read or clear the information history using the **MEXE02** software.



Information history is cleared when the main power supply and control power supply of the driver are turned off because it is stored in the RAM.

3-2 Information list

Information item	Information bit output signal	Cause	Reset condition
Assigned I/O status	INFO-USRIO	The I/O signal set in the "INFO-USRIO output selection" parameter was turned ON.	The I/O signal set in the INFO-USRIO output selection" parameter was turned OFF.
Position deviation	INFO-POSERR	The deviation between the command position and the feedback position exceeded the value set in the "Position deviation information" parameter in the motor output shaft.	The deviation between the command position and the feedback position fell below the value set in the "Position deviation information" parameter in the motor output shaft.
Driver temperature	INFO-DRVTMP	The internal temperature of the driver exceeded the value set in the "Driver temperature information" parameter.	The internal temperature of the driver fell below the value set in the "Driver temperature information" parameter.
Motor temperature	INFO-MTRTMP	The detection temperature of the encoder exceeded the value set in the "Motor temperature information" parameter.	The detection temperature of the encoder fell below the value set in the "Motor temperature information" parameter.
Overvoltage	INFO-OVOLT	<ul style="list-style-type: none"> • The voltage of the main power supply exceeded the value set in the "Overvoltage information" parameter. • A large load inertia was suddenly stopped. • Vertical operation (elevating operation) was performed. 	The voltage of the main power supply fell below the value set in the "Overvoltage information" parameter.
Undervoltage	INFO-UVOLT	<ul style="list-style-type: none"> • The voltage of the main power supply fell below the value set in the "Undervoltage information" parameter. • The main power supply was shut off momentarily or a voltage was insufficient. 	The voltage of the main power supply exceeded the value set in the "Undervoltage information" parameter.
Overload time	INFO-OLTIME	A load exceeding the maximum torque was applied for a time period exceeding the value set in the "Overload time information" parameter.	The overload counter fell below the value set in the "Overload time information" parameter.
Speed	INFO-SPD	The feedback speed of the motor exceeded the value set in the "Speed information" parameter.	The feedback speed of the motor fell below the value set in the "Speed information" parameter.

Information item	Information bit output signal	Cause	Reset condition
Start operation error	INFO-START	<ul style="list-style-type: none"> • The operation start signal in the direction having been stopped by the FW-BLK input or RV-BLK input was turned ON. • The operation start signal in the direction having been stopped by the FW-LS input or RV-LS input was turned ON. • The operation start signal in the direction having been stopped by the software limit was turned ON. • When operation could not be executed (e.g., the READY output was OFF), the operation start signal was turned ON. 	Operation was started properly.
Start ZHOME error	INFO-ZHOME	<ul style="list-style-type: none"> • When the coordinates were not set (the ABSPEN output was OFF), the ZHOME input was turned ON. • When the motor was used with the electrical home coordinate system (the EL-PRST input was ON), return-to-home operation was performed. 	Operation was started properly.
Preset request	INFO-PR-REQ	Preset was executed by the position preset or return-to-home operation.	Preset was completed.
Electronic gear setting error	INFO-EGR-E	The resolution set in the "Electronic gear A" parameter and the "Electronic gear B" parameter was out of the specification.	The resolution was set in the range of the specification.
Wrap setting error	INFO-RND-E	The resolution and the "Initial coordinate generation & wrap setting range" parameter were inconsistent.	The "Initial coordinate generation & wrap setting range" parameter was set in the range of the specifications.
Forward operation prohibition	INFO-FW-OT	<ul style="list-style-type: none"> • The positive software limit was exceeded. • Either the FW-LS input or the FW-BLK input was turned ON. 	The position of the motor was in the range of the positive software limit, and in addition, both the FW-LS input and the FW-BLK input were turned OFF.
Reverse operation prohibition	INFO-RV-OT	<ul style="list-style-type: none"> • The negative software limit was exceeded. • Either the RV-LS input or the RV-BLK input was turned ON. 	The position of the motor was in the range of the negative software limit, and in addition, both the RV-LS input and the RV-BLK input were turned OFF.
Cumulative load 0	INFO-CULD0	The cumulative load exceeded the value set in the "Cumulative load 0 information" parameter.	The cumulative load fell below the value set in the "Cumulative load 0 information" parameter.
Cumulative load 1	INFO-CULD1	The cumulative load exceeded the value set in the "Cumulative load 1 information" parameter.	The cumulative load fell below the value set in the "Cumulative load 1 information" parameter.
Tripmeter	INFO-TRIP	The travel distance of the motor exceeded the value set in the "Tripmeter information" parameter.	<p>After one of the following operations was performed, the travel distance (Tripmeter) of the motor fell below the value set in the "Tripmeter information" parameter.</p> <ul style="list-style-type: none"> • The "Tripmeter information" parameter was set again. • The "Clear tripmeter" of the maintenance command was executed.

Information item	Information bit output signal	Cause	Reset condition
Odometer	INFO-ODO	The cumulative travel distance of the motor exceeded the value set in the "Odometer information" parameter.	After the following operation was performed, the cumulative travel distance (Odometer) of the motor fell below the value set in the "Odometer information" parameter. <ul style="list-style-type: none"> • The "Odometer information" parameter was set again.
Start operation restricted mode	INFO-DSLMTD	<ul style="list-style-type: none"> • "Teaching, remote operation" was executed using the MEXE02 software. • Configuration was executed. • Data was written to the driver from the MEXE02 software. • "Restored to the factory setting" was executed using the MEXE02 software. 	<ul style="list-style-type: none"> • Teaching, remote operation was canceled. • Configuration was completed. • Writing data was completed. • Data was returned to the factory setting.
I/O test mode	INFO-IOTEST	<ul style="list-style-type: none"> • "I/O test" was executed with the MEXE02 software. • Configuration was executed. 	<ul style="list-style-type: none"> • The I/O test mode was canceled. • Configuration was completed.
Configuration request	INFO-CFG	The parameter that required executing Configuration was changed.	Configuration was executed.
Reboot request	INFO-RBT	The parameter that required rebooting was changed.	Reboot was executed.



If information of Preset request was generated for 100 ms or more in a state where the "Information auto clear" parameter was set to "0: Disable," the preset may have been failed. There are the following two possible reasons that the preset was failed.

- The ABZO sensor is not connected to the driver.
- The preset was executed in a state where the position deviation between the command position and the feedback position was 1.8° or more.

4 Troubleshooting and remedial actions

In motor operation, the motor or the driver may not operate properly due to an improper setting or wrong connection.

When the motor operation cannot be performed properly, refer to the contents provided in this chapter and take an appropriate remedial action.

If the problem persists, contact your nearest Oriental Motor sales office.

Phenomenon	Possible cause	Remedial action
<ul style="list-style-type: none"> The motor is not excited. The motor output shaft can be rotated by hand. 	Connection error of the motor cable.	Check the motor connection.
	The FREE input is being ON.	Turn the FREE input OFF.
The motor has a holding torque even if it is put into a non-excitation state.	Effect of dynamic brake.	If the motor is put into a non-excitation state, the motor windings are brought into a state of being short-circuited inside the driver, generating a larger holding torque than when no current is supplied (dynamic brake). To release the dynamic brake, shut off the main power supply and control power supply or turn the FREE input ON.
The motor does not rotate.	When an electromagnetic brake motor is used, the electromagnetic brake is in a state of holding the motor shaft.	<ul style="list-style-type: none"> Check the connection of the electromagnetic brake. Check the input voltage of the control power supply.
	The position (travel amount) is not set in the operation data when positioning operation is performed.	Check the operation data.
	When JOG operation, high-speed JOG operation, or continuous macro operation is performed, the input in the forward direction and that in the reverse direction are simultaneously ON.	Turn both inputs in the forward direction and the reverse direction OFF, and then turn either one ON.
	The STOP input is being ON.	Turn the STOP input OFF.
The motor rotates in the direction opposite to the specified direction.	The "Motor rotation direction" parameter is set wrongly.	Check the setting of the "Motor rotation direction" parameter.
The gearhead output shaft rotates in the direction opposite to the motor.	A geared motor that rotates in the direction opposite to the motor output shaft is used.	<ul style="list-style-type: none"> With the TS geared type, the gearhead output shaft rotates in the direction opposite to the motor when the gear ratio is 20 or 30. With the Harmonic geared type, the gearhead output shaft always rotates in the direction opposite to the motor.
Motor operation is unstable.	Connection error of the motor cable or the power supply cable.	Check the connections between the driver, motor and power supply.
	A value set in the "Base current" parameter is too low.	Check the setting of the "Base current" parameter. If the motor current value is low with respect to a load, the torque will also be low and the operation will be unstable.
	The "Main power mode" parameter is set wrongly.	Check the setting of the "Main power mode" parameter.
	The main power supply starts up slowly or the voltage of the main power supply is unstable.	Set the "Main power mode" parameter to "0: 24 VDC" or "1: 48 VDC" according to the rated voltage of the main power supply.

Phenomenon	Possible cause	Remedial action
Motor vibration is too large.	The load is small.	Lower the current with the "Base current" parameter. If the motor output torque is too large with respect to a load, vibration will increase.
	The "Main power mode" parameter is set wrongly.	Check the setting of the "Main power mode" parameter.
	The main power supply starts up slowly or the voltage of the main power supply is unstable.	Set the "Main power mode" parameter to "0: 24 VDC" or "1: 48 VDC" according to the rated voltage of the main power supply.
The electromagnetic brake is not put into a state of releasing the motor shaft.	The power is not supplied to the electromagnetic brake.	Check the connection of the electromagnetic brake.
	A voltage for the electromagnetic brake is insufficient.	Check the input voltage of the control power supply.



When an alarm is being generated, check the alarm message via PROFINET or the **MEXE02** software.

6 Reference materials

◆ Table of contents

1	Timing chart	116
2	Specifications	118
	2-1 Product specifications.....	118
	2-2 General specifications.....	118
3	Regulations and standards.....	119



1 Timing chart

■ Power activation

● When a control power supply is used

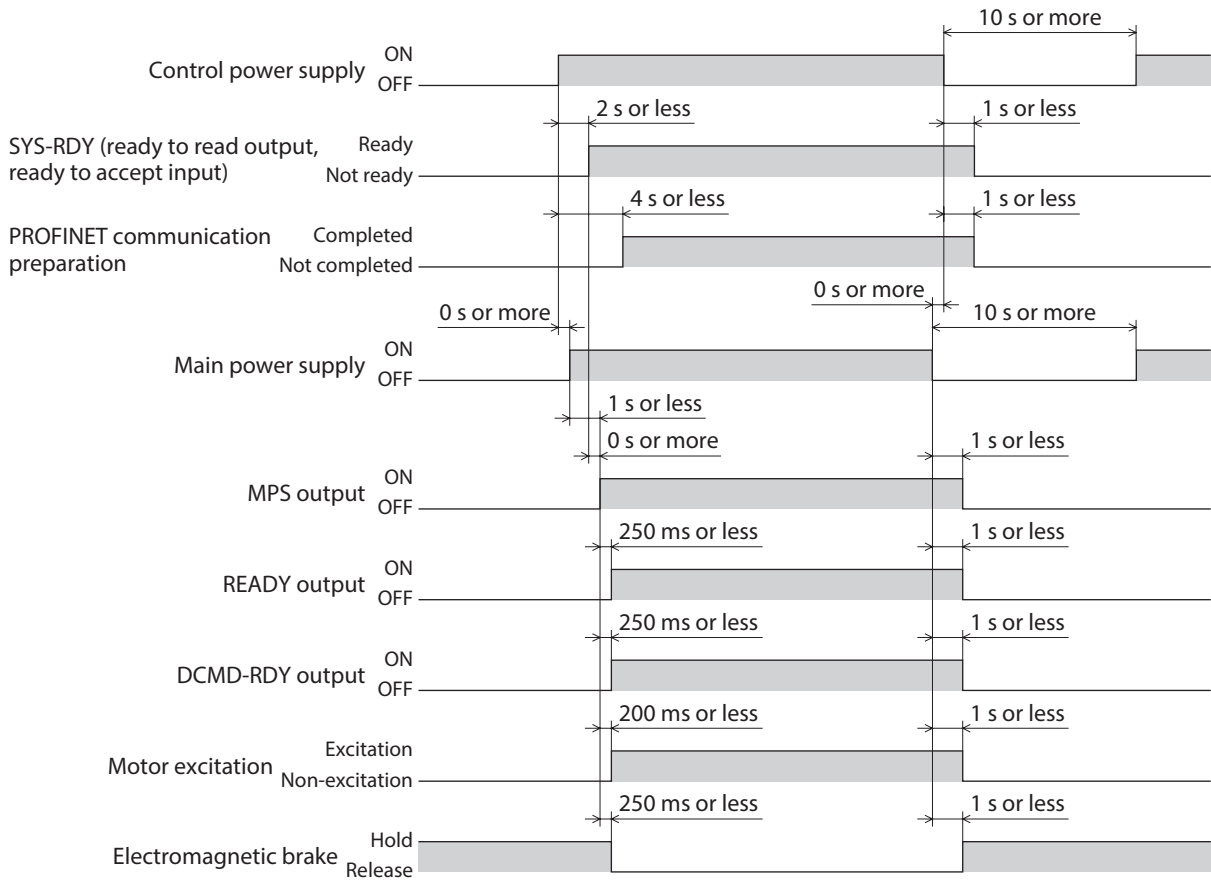

● When a control power supply is not used

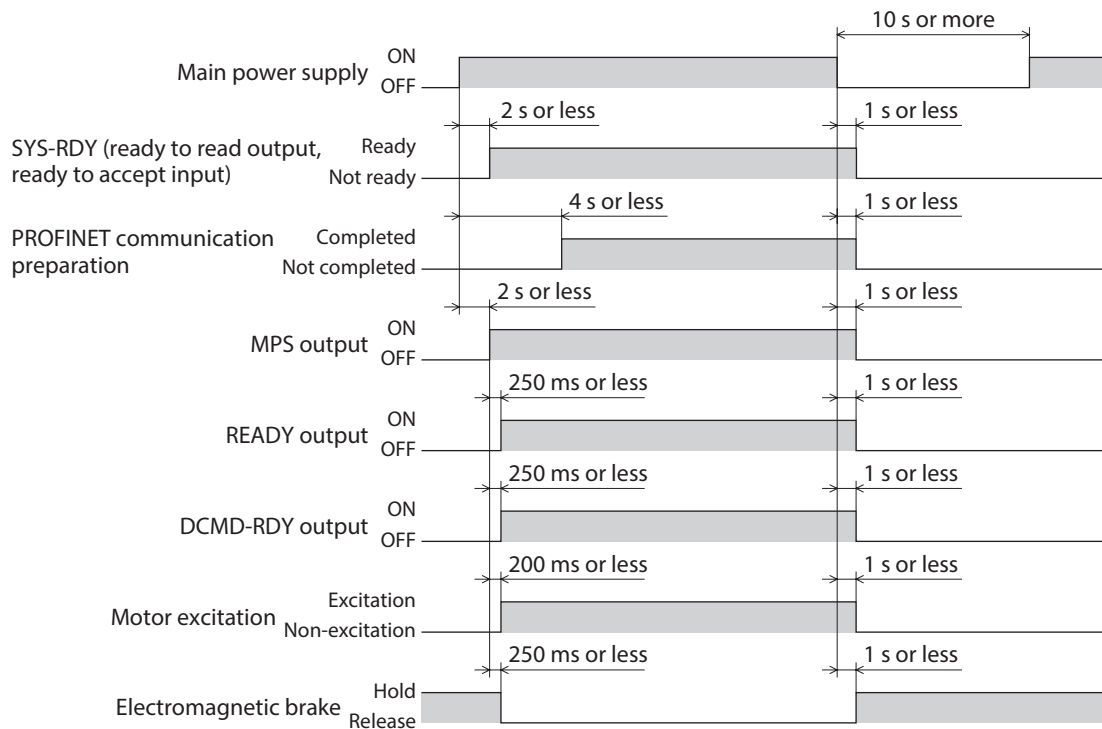

2 Specifications

2-1 Product specifications

Main power supply	Rated voltage	24 VDC±5 % 48 VDC±5 %
	Input current	0.4 to 3.7 A *1
	Allowable operating voltage	24 VDC input: 20 to 32 VDC (22.8 to 32 VDC) *2 48 VDC input: 40 to 55 VDC
Control power supply	Rated voltage	24 VDC±5 % 48 VDC±5 %
	Input current	0.15 A (0.4 A) *3
	Allowable operating voltage	24 VDC input: 20 to 32 VDC (22.8 to 32 VDC) *2 48 VDC input: 40 to 55 VDC
Interface	Control input	20 to 32 VDC Number of input points: 2, photocoupler
	Field network	PROFINET

*1 The input current varies depending on the motor combined. Check on p.25.

*2 The value in parentheses () is the one when the electromagnetic brake motor is connected.

*3 The value in parentheses () is the one when the electromagnetic brake motor is connected. The **AZM46** type is 0.23 A.

2-2 General specifications

Degree of protection		IP20
Operating environment	Ambient temperature	0 to +50 °C (+32 to +122 °F) (non-freezing)
	Humidity	85 % or less (non-condensing)
	Altitude	Up to 1,000 m (3,300 ft.) above sea level
	Surrounding atmosphere	No corrosive gas, dust, water or oil.
Storage environment Shipping environment	Ambient temperature	-25 to +70 °C (-13 to 158 °F) (non-freezing)
	Humidity	85 % or less (non-condensing)
	Altitude	Up to 3,000 m (10,000 ft.) above sea level
	Surrounding atmosphere	No corrosive gas, dust, water or oil

3 Regulations and standards

■ UL Standards, CSA Standards

This product is recognized by UL under the UL and CSA Standards.

The driver is not provided with the electronic motor overload protection and the motor overtemperature protection specified in UL and CSA Standards.

■ CE Marking / UKCA Marking

This product is affixed with the marks under the following directives/regulations.

● EU EMC Directive / UK EMC Regulations

Refer to “4-7 Compliance with the EMC Directive/Regulations” on p.28 for details about conformity.

● EU RoHS Directive / UK RoHS Regulations

This product does not contain the substances exceeding the restriction values.

- Unauthorized reproduction or copying of all or part of this manual is prohibited.
If a new copy is required to replace an original manual that has been damaged or lost, please contact your nearest Oriental Motor sales office.
- Oriental Motor shall not be liable whatsoever for any problems relating to industrial property rights arising from use of any information, circuit, equipment or device provided or referenced in this manual.
- Characteristics, specifications and dimensions are subject to change without notice.
- While we make every effort to offer accurate information in the manual, we welcome your input. Should you find unclear descriptions, errors or omissions, please contact the nearest office.
- **Orientalmotor**, ***αSTEP***, and ABZO sensor are registered trademarks or trademarks of Oriental Motor Co., Ltd., in Japan and other countries.
PROFINET is a trademark or a registered trademark of PROFIBUS Nutzerorganisation e.V. (PNO).
Other product names and company names mentioned in this manual may be registered trademarks or trademarks of their respective companies and are hereby acknowledged. The third-party products mentioned in this manual are recommended products, and references to their names shall not be construed as any form of performance guarantee. Oriental Motor is not liable whatsoever for the performance of these third-party products.

© Copyright ORIENTAL MOTOR CO., LTD. 2022

Published in February 2026

- Please contact your nearest Oriental Motor office for further information.

ORIENTAL MOTOR U.S.A. CORP.
Technical Support Tel:800-468-3982
8:30am EST to 5:00pm PST (M-F)

ORIENTAL MOTOR (EUROPA) GmbH
Schiessstraße 44, 40549 Düsseldorf, Germany
Technical Support Tel:00 800/22 55 66 22

ORIENTAL MOTOR (UK) LTD.
Blythe Valley Business Park,
Central Blvd Blythe Valley Park,
Solihull B90 8AG, United Kingdom
Tel:+44-1926-671220

ORIENTAL MOTOR (FRANCE) SARL
Tel:+33-1 47 86 97 50

ORIENTAL MOTOR ITALIA s.r.l.
Tel:+39-02-93906347

ORIENTAL MOTOR ASIA PACIFIC PTE. LTD.
Singapore
Tel:1800-842-0280

ORIENTAL MOTOR (MALAYSIA) SDN. BHD.
Tel:1800-806-161

ORIENTAL MOTOR (THAILAND) CO., LTD.
Tel:1800-888-881

ORIENTAL MOTOR (INDIA) PVT. LTD.
Tel:1800-120-1995 (For English)
1800-121-4149 (For Hindi)

TAIWAN ORIENTAL MOTOR CO., LTD.
Tel:0800-060708

SHANGHAI ORIENTAL MOTOR CO., LTD.
Tel:400-820-6516

INA ORIENTAL MOTOR CO., LTD.
Korea
Tel:080-777-2042

ORIENTAL MOTOR CO., LTD.
4-8-1 Higashiueno, Taito-ku, Tokyo
110-8536 Japan
Tel:+81-3-6744-0361
www.orientalmotor.co.jp/ja