

OPERATING MANUAL

Regeneration Unit

Table of contents

Introduction	1	Inspection and maintenance	6
Safety precautions	1	Alarms.....	6
Precautions for use	2	Timing chart	6
Preparation	2	Specifications.....	6
Installation	2	Regulations and standards	7
Connection	3		

Introduction

■ Before using the product

Only qualified personnel of electrical and mechanical engineering should work with the product.

Use the product properly after thoroughly reading the section "Safety precautions." In addition, be sure to observe the contents described in warning, caution, and note in this manual.

The product described in this manual is designed and manufactured to be incorporated in general industrial equipment. Do not use it for any other purpose. Oriental Motor Co., Ltd. is not responsible for any compensation for damage caused through failure to observe this warning.

■ Overview of the product





This product is a regeneration unit for exclusive use with DC input products. Connecting the regeneration unit can suppress the voltage rise caused by the regenerative power of the motor.

The 24 VDC type and 48 VDC type are available according to the power supply voltage.



Safety precautions

The precautions described below are intended to ensure the safe and proper use of the product and to prevent the user and other personnel from exposure to the risk of injury. Use the product only after carefully reading and fully understanding these instructions.

Description of signs

	Handling the product without observing the instructions that accompany a "WARNING" symbol may result in serious injury or death.
	Handling the product without observing the instructions that accompany a "CAUTION" symbol may result in injury or property damage.
	The items under this heading contain important handling instructions that the user should observe to ensure safe use of the product.
	The items under this heading contain related information and contents to gain a further understanding of the text in this manual.

Description of graphic symbols



	Indicates "prohibited" actions that must not be performed.
	Indicates "compulsory" actions that must be performed.

Thank you for purchasing an Oriental Motor product.



This Operating Manual describes product handling procedures and safety precautions.

- Please read it thoroughly to ensure safe operation.
- Always keep the manual where it is readily available.

⚠ WARNING

	<ul style="list-style-type: none"> • Do not use the product in explosive or corrosive environments, in the presence of flammable gases, in places subjected to splashing water, or near combustibles. Doing so may result in fire or injury. • Do not transport, install, connect, or inspect the product while the power is supplied. Doing so may result in damage to equipment. • Do not touch the regeneration unit while the power is on. Doing so may result in fire. • Do not forcibly bend, pull, or pinch the cable. Doing so may result in fire. • Do not disassemble or modify the regeneration unit. Doing so may result in injury or damage to equipment.
	<ul style="list-style-type: none"> • Assign qualified personnel to the task of installing, wiring, operating, inspecting, and troubleshooting the product. Handling by unqualified personnel may result in fire, injury, or damage to equipment. • If an alarm (protective function) of the regeneration unit is generated, turn off the power and eliminate the cause. Continuing the operation without correcting the cause of the problem may cause the regeneration unit or the connected motor and driver to malfunction, resulting in injury or damage to equipment. • Install the regeneration unit in an enclosure. Failure to do so may result in injury. • Observe the specifications for the power supply voltage of the regeneration unit. Failure to do so may result in fire. • Connect the product securely according to the connection diagram. Failure to do so may result in fire. • Turn off the power supply in the event of a power failure. Failure to do so may result in injury or damage to equipment.

⚠ CAUTION

	<ul style="list-style-type: none"> • Do not use the regeneration unit beyond its specifications. Doing so may result in injury or damage to equipment. • Keep fingers and objects out of the openings in the regeneration unit. Failure to do so may result in fire or injury. • Do not touch the regeneration unit while the power is on or for a period of time after the power is turned off. The surface is hot, and this may cause a skin burn(s). • Do not forcibly bend or pull the cable that is connected to the regeneration unit. Doing so may cause damage to the product. • Keep the area around the regeneration unit free of combustible materials. Failure to do so may result in fire or a skin burn(s). • Do not leave anything around the regeneration unit that would obstruct ventilation. Doing so may result in damage to equipment.
	<ul style="list-style-type: none"> • Use the regeneration unit and driver only in the specified combination. Failure to do so may result in fire. • Provide an emergency stop device or emergency stop circuit external to the equipment so that the entire system will operate safely in the event of a system failure or malfunction. Failure to do so may result in injury. • Use a DC power supply with reinforced insulation on its primary and secondary sides for a power supply. Failure to do so may result in electric shock. • If any abnormality is observed, stop the operation immediately to turn off the power supply. Failure to do so may result in fire or injury.

CAUTION



- The surface temperature of the regeneration unit may exceed 70 °C (158 °F) even under normal operating conditions. If the operator is allowed to approach the regeneration unit during operation, affix a warning label on a conspicuous place as shown in the figure. The surface is hot, and this may cause a skin burn(s).



Warning label

Precautions for use

- When conducting the insulation resistance measurement or the dielectric strength test, be sure to separate the connection between the regeneration unit and the driver.

Conducting the insulation resistance measurement or the dielectric strength test with the regeneration unit and driver connected may result in damage to the product.

- Do not touch the regeneration unit while the power is on or for a period of time after the power is turned off.
- Do not touch the regeneration unit as it may have a high temperature while the power is on or for a period of time after the power is turned off. The surface is hot, and this may cause a skin burn(s).
- Maintain sufficient clearance so that heat generated by the regeneration unit does not affect surrounding equipment.

- Note on connecting a power supply whose positive terminal is grounded

The power supply input terminal of the regeneration unit (Vcc+IN) and the power supply output terminal (Vcc+OUT) are not electrically insulated. When grounding the positive terminal of the power supply, do not connect the driver or equipment (PC, etc.) whose negative terminal is grounded. Doing so may cause the regeneration unit and this equipment to short, damaging both. When connecting, do not ground equipment.

- Noise elimination measures

Refer to p.4 for noise elimination measures.

Preparation

Checking the product

Verify that the items listed below are included. Report any missing or damaged items to the Oriental Motor sales office from which you purchased the product.

- Regeneration unit..... 1 unit
- Instructions and Precautions for Safe Use..... 1 copy

How to identify the product model

Check the model name of the regeneration unit against that shown on the nameplate.

Refer to "Information about nameplate" for how to identify the nameplate.

RG - **4** - **K**

1 2 3 4

1	Type	RG : Regeneration resistor
2	Reference number	
3	Regenerative ability	4 : 4 W (average regenerative power)
4	Power supply voltage	K : 24 VDC N : 48 VDC

Information about nameplate

The figure shows an example.

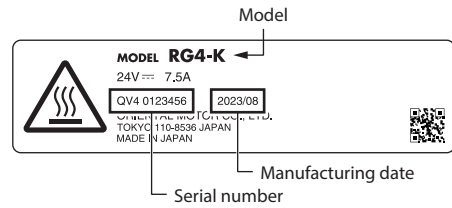

Names and functions of parts

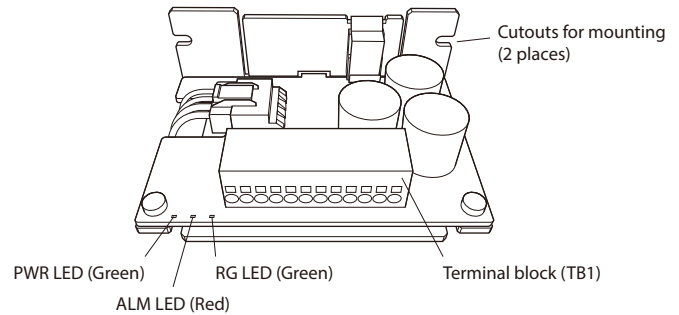

Name	Description
PWR LED (Green)	This LED is lit while the power supply is turned on.
ALM LED (Red)	This LED is lit if an alarm is generated (a protective function is triggered).
RG LED (Green)	This LED is lit during regeneration processing.
Terminal block (TB1)	Connects a power supply and output signals.

Applicable driver

The regeneration unit can be connected with a driver that can return regenerative power to the power supply.

The driver should meet the specifications for the current and the regenerative power of the regeneration unit.

Type	Series	Example of model name
Stepping Motor	AZ Series • mini Driver	AZD-KR2D
	CVD Series driver • Pulse input type • SC type	CVD503B-K

Installation

Installation location

The regeneration unit is designed and manufactured to be incorporated in equipment. Install it in a well-ventilated location that provides easy access for inspection. The location must also satisfy the following conditions:

- Inside an enclosure that is installed indoors (provide vent holes)
- Operating ambient temperature: 0 to +50 °C (+32 to +122 °F) (non-freezing)
- Operating ambient humidity: 85 % or less (non-condensing)
- Area free of explosive atmosphere, toxic gas (such as sulfuric gas), or liquid
- Area not exposed to direct sun
- Area free of excessive amount of dust, iron particles or the like
- Area not subject to splashing water (rain, water droplets), oil (oil droplets) or other liquids
- Area free of excessive salt
- Area not subject to continuous vibration or excessive shocks
- Area free of excessive electromagnetic noise (from welders, power machinery, etc.)
- Area free of radioactive materials, magnetic fields, or vacuum
- Up to 1,000 m (3,300 ft.) above sea level

■ Installation method

The regeneration unit is designed on the basis of heat radiation by air convection or heat conduction to an enclosure. Install it to a flat metal plate offering high heat conductivity [corresponding to an aluminum plate of 100×100×2 mm (3.94×3.94×0.08 in.)].

When installing the regeneration, use the cutouts for mounting and secure to the metal plate with two screws (M3: not included).

Note

- Install the regeneration unit in an enclosure.
- Do not install any equipment that generates a large amount of heat or noise near the regeneration unit.
- Do not install the regeneration unit underneath a host controller or equipment sensitive to heat.
- If the ambient temperature of the regeneration unit exceeds 50 °C (122 °F), reconsider the ventilation conditions, such as providing forced cooling by using fans.
- Be sure to install the regeneration unit vertically (in vertical position).

● Dimensions [Unit: mm (in.)]

Mass: 0.11 kg (3.9 oz)

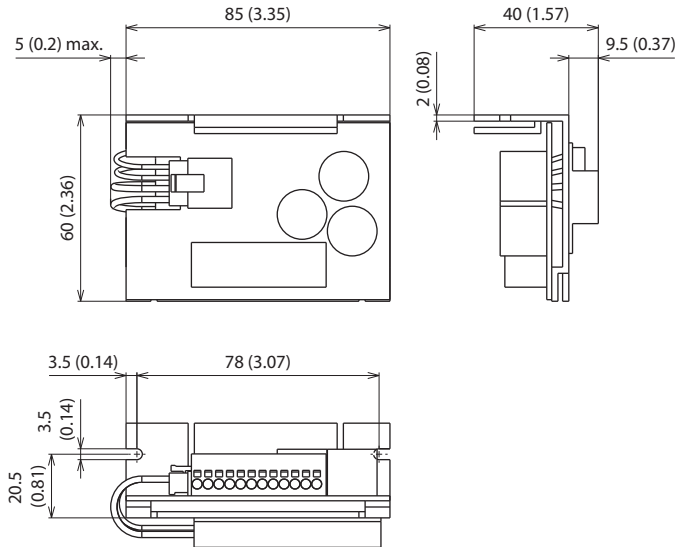

Connection

⚠ WARNING For protection against electric shock, do not turn on the power supply until the wiring is completed.

■ Connection example

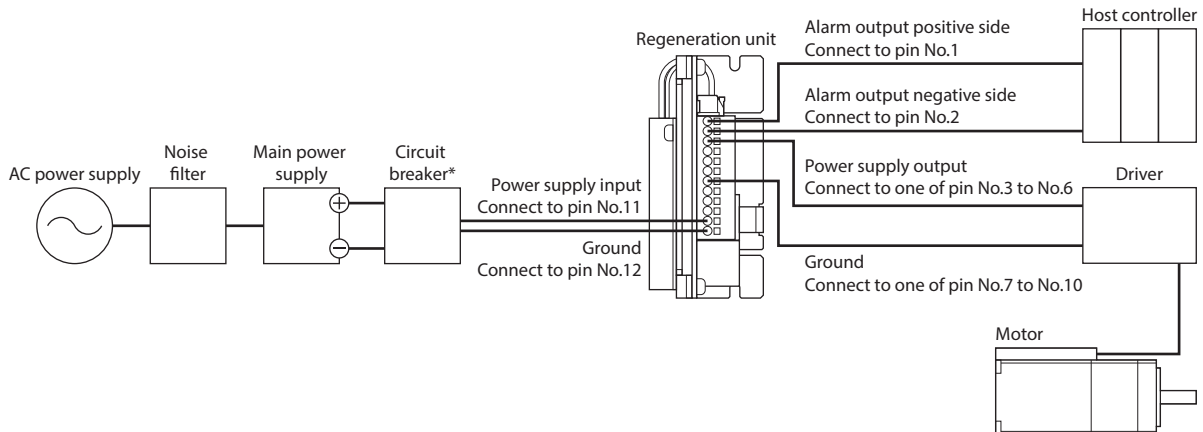

* It is recommended that a circuit breaker or a circuit protector is connected because incorrect wiring of the power supply may cause the internal input circuit to short circuit.

Note

- Connect the lead wires securely. Insecure connection may cause malfunction or damage to the regeneration unit.
- Keep a wiring distance of 2 m (6.6 ft.) or less between the regeneration unit and the driver. If the wiring distance exceeds 2 m (6.6 ft.), the electrical noise or heat generated by the regeneration unit may increase.
- Keep 2 m (6.6 ft.) or less for the length of the power supply cable.
- When connecting or disconnecting a connector, turn off the power supply, and check the following.
 - The PWR LED is off.
 - The regeneration unit and heat sink are sufficiently cooled.

■ Applicable lead wire

Pin number	Recommended wire size	Lead wire strip length
1, 2	AWG24 to 16 (0.2 to 1.25 mm ²)	10 mm (0.39 in.)
3 to 12	AWG20 to 16 (0.5 to 1.25 mm ²)	

Note

Use lead wires suitable for the rated current of the regeneration unit and that of the driver. If the current flow exceeds the rated current of the lead wire, the lead wire may be damaged.

Pin assignment

Pin number	Signal name	Description
1	ALM OUT +	Alarm out positive side
2	ALM OUT -	Alarm out negative side
3	Vcc+OUT	Power supply output
4		
5		
6		
7	GND	Power supply ground
8		
9		
10		
11	Vcc+IN	Power supply input
12	GND	Power supply ground

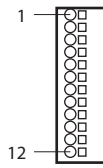

Internal input circuit



- Use output signals at 4.5 to 30 VDC, 10 mA or less. If the current exceeds 10 mA, connect an external resistor R0 to keep the current at 10 mA or less.
- The saturation voltage of the output signal is 1.6 V maximum.

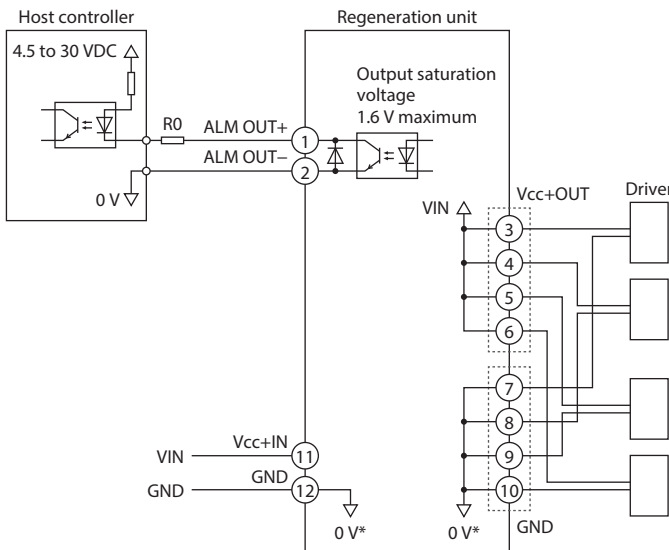

* They are common within the regeneration unit.

Connection example with a current sink output circuit

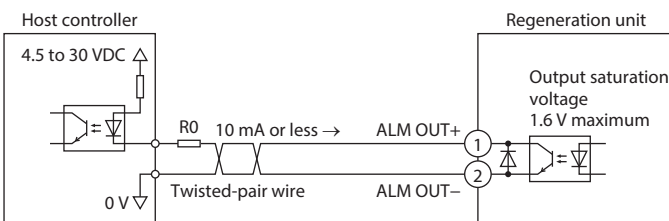

Connection example with a current source output circuit

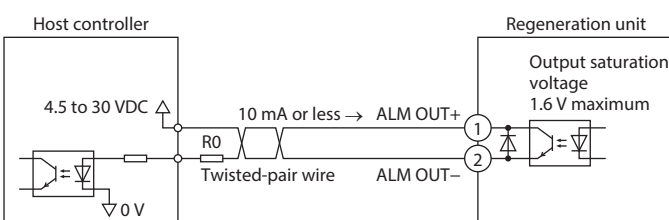

Noise elimination measures

There are two types of electrical noises: One is a noise to invade into the regeneration unit from the outside and cause the regeneration unit malfunction, and the other is a noise to emit from the regeneration unit and cause peripheral equipment malfunction.

For the noise that is invaded from the outside, take measures to prevent the regeneration unit malfunction. It is necessary to take appropriate measures because the signal lines are very likely to be affected by the noise.

For the noise that is emitted from the regeneration unit, take measures to suppress it.

Measures against electrical noise

There are the following three methods mainly to take measures against the electrical noise.

Noise suppression

- When relays or electromagnetic switches are used, use noise filters or CR circuits to suppress surge generated by them.
- Cover the driver by a metal plate such as aluminum. This is effective in shielding the electrical noise emitted from the regeneration unit.

Prevention of noise propagation

- Connect a noise filter on the input side of the DC power supply.
- Keep power lines at least 200 mm (7.87 in.) away from signal lines, and do not bundle or wire them in parallel. If the power lines cross over the signal lines, wire them at right angles.
- Keep cables as short as possible without coiling and bundling extra lengths.
- Grounding multiple points will increase the effectiveness of blocking the electrical noise because the impedance at the grounding points is reduced. However, ground them so that a potential difference does not occur among the grounding points.
- To ground a shielded cable, use a metal cable clamp that can maintain contact with the entire circumference of the shielded cable, and ground as close to the regeneration unit as possible.

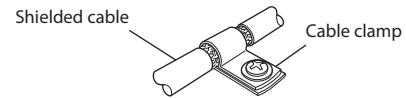

Suppression of effect by noise propagation

Loop the noise propagated cable around a ferrite core. Doing so will prevent the propagated noise from invading into the regeneration unit or emitting from it. The frequency band in which an effect by the ferrite core can be seen is generally 1 MHz or more. Check the frequency characteristics of the ferrite core used. To increase the effect of noise attenuation by the ferrite core, loop the cable many times.

Noise suppression products

Noise filter

- Connect a noise filter (or equivalent) in the table below on the input side of the DC power supply. When a power transformer is used, be sure to connect a noise filter on the AC input side of the power transformer. Doing so will prevent the propagated noise through the power line. Install the noise filter as close to the input terminals of DC power supply as possible.

Manufacturer	Part number
SOSHIN ELECTRIC CO., LTD.	HF2010A-UPF
Schaffner EMC	FN2070-10-06

- Use the AWG18 (0.75 mm²) or thicker wire for the input and output cables of the noise filter, and secure them firmly using a cable clamp or others so that the cable does not come off the enclosure.
- Place the input cable as far away from the output cable as possible and do not wire the cables in parallel. If the input and output cables are placed at a close distance or wired in parallel, the noise in the enclosure will affect the power cable through stray capacitance, and the noise suppression effect will be reduced.
- Connect the ground terminal of the noise filter to the grounding point, using as thick and short a wire as possible.
- When connecting a noise filter in an enclosure, wire the input cable of the noise filter as short as possible. Wiring in long distance may reduce the noise suppressing effect.

● Oriental Motor's noise suppression products

● Surge suppressors

These are effective to suppress the surge which occurs in a relay contact part. Connect when using a relay or electromagnetic switch. A CR circuit for surge suppression and a CR circuit module are provided. Check on the Oriental Motor Website for the model.

■ Compliance with EMC Directive/Regulations

Effective measures must be taken against EMI that the regeneration unit may cause to adjacent control-system equipment, as well as EMS of the regeneration unit itself, in order to prevent a serious functional impediment in the machinery. The use of the following installation and wiring methods will enable the regeneration unit to be compliant with the EMC Directive/Regulations. Oriental Motor conducts EMC testing of the regeneration unit in accordance with "Example of installation and wiring." The user is responsible for ensuring the machine's compliance with EMC, based on the installation and wiring explained below.

⚠ CAUTION

This equipment is not intended for use in residential environments nor for use on a low-voltage public network supplied in residential premises, and it may not provide adequate protection to radio reception interference in such environments.

● Example of installation and wiring

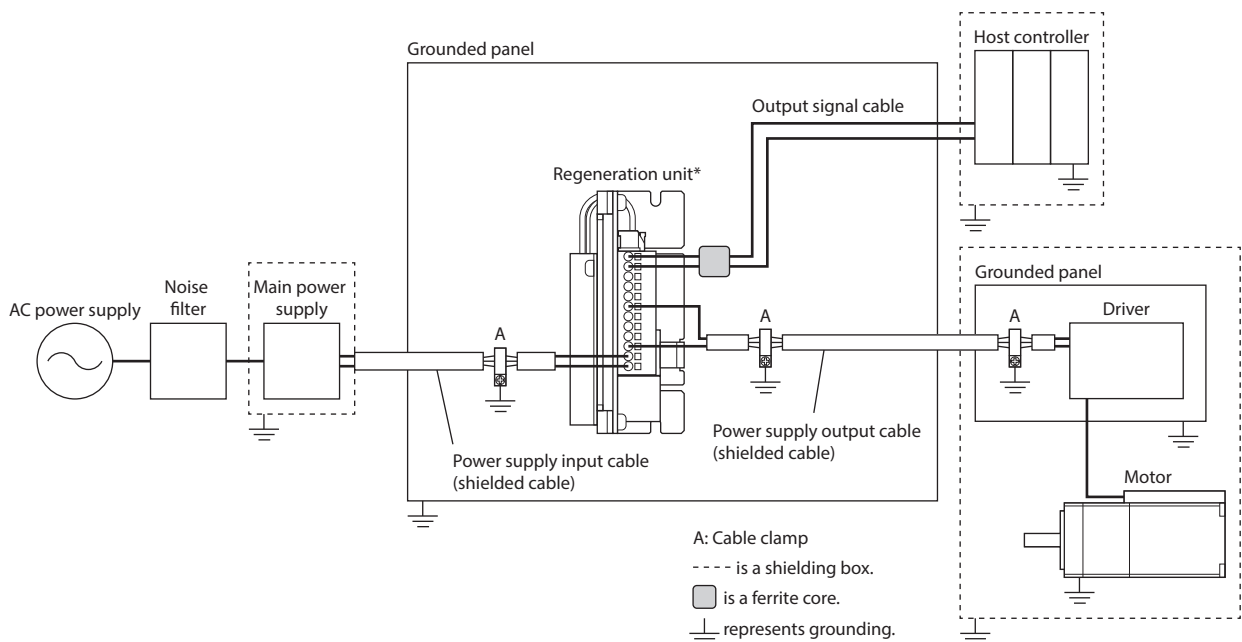

* The regeneration unit is grounded by making the heat sink contact directly with the grounded panel.

Note

The regeneration unit uses components that are sensitive to static electricity. Take measures against static electricity since it may cause the regeneration unit to malfunction or be damaged.

● Connecting a power supply

Use a DC power supply that complies with the EMC Directive/Regulations for the power supply. Use shielded cables to wire and ground as short as possible. Refer to "Prevention of noise propagation" on p.4 for grounding the shielded cable.

● Connecting the power supply output cable

Use a cable that complies with the conditions of the EMC Directive/Regulations of the driver to be connected. For conditions that comply with the EMC Directive/Regulations of the driver, refer to the OPERATING MANUAL of each product.

● Connecting the signal cable

Refer to "Prevention of noise propagation" on p.4.

● Grounding method

- Wires used to ground the regeneration unit must be as thick and short as possible so that no potential difference is generated between the grounding points.
- Choose a large, thick and uniformly conductive surface for the grounding point.

Inspection and maintenance

Inspection

It is recommended that the following items be checked periodically. If any abnormality occurs, discontinue use of the product and contact your nearest Oriental Motor sales office.

Inspection items

- Check to see if any of the mounting screws of the regeneration unit are loose.
- Check to see if the connection part of the regeneration unit is loose.
- Check to see if there is no dust adhering to the regeneration unit.
- Check to see if there is an unusual odor or appearance for the regeneration unit.

Note The regeneration unit uses semiconductor components. Since static electricity may damage semiconductor components, be extremely careful when handling it.

Warranty

Check on the Oriental Motor Website for the product warranty.

Disposal

Dispose the product correctly in accordance with laws and regulations, or instructions of local governments.

Alarms

When the temperature of the thermostat built into the regeneration unit reaches the operating temperature, an alarm of Regeneration resistor overheating is generated. If an alarm is generated, the ALM output will be turned OFF to stop regeneration processing. At the same time, the ALM LED is lit in red.

When the temperature of the thermostat drops to the reset temperature, the alarm is automatically canceled.

Specifications of built-in thermostat

Operating temperature	95 °C±5 °C (203 °F±9 °F)
Reset temperature	65 °C±15 °C (149 °F±27 °F)

Note If the product is installed in a closed place such as a control cabinet or near a heat-radiating object, an alarm of Regeneration resistor overheating is likely to be generated. When an alarm is generated, use a fan to cool the regeneration unit.

Timing chart

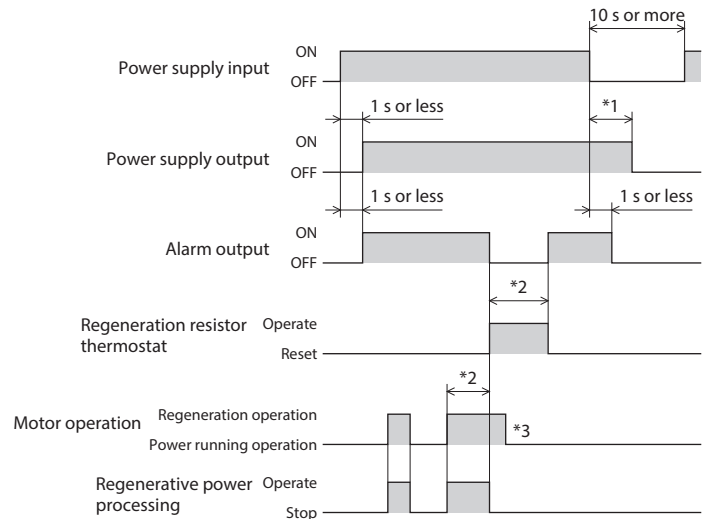

*1 It varies depending on the connected load.

*2 It varies depending on the ambient temperature and heat radiation conditions.

*3 If regeneration operation is continued while regenerative power processing is stopped, the internal voltage of the connected driver may rise to generate an alarm of Overvoltage, causing the operation to stop.

Specifications

Product specifications

RG4-K

Number of units to be connected		4 units maximum
Power supply input	Rated voltage	24 VDC
	Allowable operating voltage	16 to 32 V*1*2
	Rated current	7.5 A
	Maximum current	12 A
Regeneration operation*3	Regeneration operating voltage (Voltage inside the circuit)	ON: 32.5 V max. OFF: 28 V min.
	Regeneration detection voltage (Difference between Vcc+OUT and Vcc+IN)	ON: 3.6 V max. OFF: 0.4 V min.
	Resistance value of built-in regeneration resistor	6 Ω
	Instantaneous regenerative power	130 W
	Continuous regenerative power	4 W
	Thermostat operating temperature	Operation: Opens at 95 °C±5 °C (203 °F±9 °F) Reset: Closes at 65 °C±15 °C (149 °F±27 °F) [Normally closed]
Interface	ALM output	4.5 to 30 VDC 10 mA or less

• **RG4-N**

Number of units to be connected		4 units maximum
Power supply input	Rated voltage	48 VDC
	Allowable operating voltage	41 to 55 V*1*2
	Rated current	7.5 A
	Maximum current	12 A
Regeneration operation*3	Regeneration operating voltage (Voltage inside the circuit)	ON: 55 V max. OFF: 48.5 V min.
	Regeneration detection voltage (Difference between Vcc+OUT and Vcc+IN)	ON: 5 V max. OFF: 0.2 V min.
	Resistance value of built-in regeneration resistor	10 Ω
	Instantaneous regenerative power	260 W
	Continuous regenerative power	4 W
	Thermostat operating temperature	Operation: Opens at 95 °C±5 °C (203 °F±9 °F) Reset: Closes at 65 °C±15 °C (149 °F±27 °F) [Normally closed]
Interface	ALM output	4.5 to 30 VDC 10 mA or less

*1 It is the operating voltage range of the regeneration unit. Use a power supply voltage that takes into account the input voltage of the connected driver and the regeneration operating voltage of the regeneration unit.

*2 The regeneration unit causes a voltage drop of up to 1.2 V between the power supply input and output. The voltage also drops in the connection cable. Use the product at the power supply voltage with these voltage drops in mind.

*3 When both the regeneration operating voltage and the regeneration detection voltage exceed the threshold, regeneration processing is performed.

■ **General specifications**

Operating environment	Ambient temperature	0 to +50 °C (+32 to +122 °F) (non-freezing)
	Ambient humidity	85 % or less (non-condensing)
	Altitude	Up to 1,000 m (3,300 ft.) above sea level
	Surrounding atmosphere	No corrosive gas or dust. No exposure to water, oil, etc.
Storage environment Shipping environment	Ambient temperature	-25 to +70 °C (-13 to +158 °F) (non-freezing)
	Ambient humidity	85 % or less (non-condensing)
	Altitude	Up to 3,000 m (10,000 ft.) above sea level
	Surrounding atmosphere	No corrosive gas or dust. No exposure to water, oil, etc.
Degree of protection		IP00

Regulations and standards

● **CE Marking / UKCA Marking**

This product is affixed with the marks under the following directive/regulations.

● **EU EMC Directive / UK EMC Regulations**

Refer to "Compliance with EMC Directive/Regulations" on p.5 for details on compliance.

● **EU RoHS Directive / UK RoHS Regulations**

This product does not contain the substances exceeding the restriction values.

- Unauthorized reproduction or copying of all or part of this manual is prohibited.
- Oriental Motor shall not be liable whatsoever for any problems relating to industrial property rights arising from use of any information, circuit, equipment or device provided or referenced in this manual.
- Characteristics, specifications and dimensions are subject to change without notice.
- While we make every effort to offer accurate information in the manual, we welcome your input. Should you find unclear descriptions, errors or omissions, please contact the nearest office.
- **Orientalmotor** is a registered trademark or trademark of Oriental Motor Co., Ltd., in Japan and other countries.

© Copyright ORIENTAL MOTOR CO., LTD. 2023

Published in October 2025

- Please contact your nearest Oriental Motor office for further information.

ORIENTAL MOTOR U.S.A. CORP.
 Technical Support Tel:800-468-3982
 8:30am EST to 5:00pm PST (M-F)

ORIENTAL MOTOR ASIA PACIFIC PTE. LTD.
 Singapore
 Tel:1800-842-0280

ORIENTAL MOTOR (EUROPA) GmbH
 Schiessstraße 44, 40549 Düsseldorf, Germany
 Technical Support Tel:00 800/22 55 66 22

ORIENTAL MOTOR (MALAYSIA) SDN. BHD.
 Tel:1800-806-161

ORIENTAL MOTOR (UK) LTD.
 Blythe Valley Business Park,
 Central Blvd Blythe Valley Park,
 Solihull B90 8AG, United Kingdom
 Tel:+44-1926-671220

ORIENTAL MOTOR (THAILAND) CO., LTD.
 Tel:1800-888-881

ORIENTAL MOTOR (FRANCE) SARL
 Tel:+33-1 47 86 97 50

ORIENTAL MOTOR (INDIA) PVT. LTD.
 Tel:1800-120-1995 (For English)
 1800-121-4149 (For Hindi)

ORIENTAL MOTOR ITALIA s.r.l.
 Tel:+39-02-93906347

TAIWAN ORIENTAL MOTOR CO., LTD.
 Tel:0800-060708

ORIENTAL MOTOR CO., LTD.
 4-8-1 Higashiueno, Taito-ku, Tokyo 110-8536
 Japan
 Tel:+81-3-6744-0361
 www.orientalmotor.co.jp/ja

SHANGHAI ORIENTAL MOTOR CO., LTD.
 Tel:400-820-6516

INA ORIENTAL MOTOR CO., LTD.
 Korea
 Tel:080-777-2042