

## OPERATING MANUAL

### 5-Phase Stepping Motors

### PK Series

## Introduction

### ■ Before using the product

Only qualified and educated personnel should work with the product. Use the product correctly after thoroughly reading the section "Safety precautions." In addition, be sure to observe the contents described in warning, caution, and note in this manual. The product described in this manual is designed and manufactured to be incorporated into general industrial equipment. Do not use it for any other purpose. Oriental Motor Co., Ltd. is not responsible for any compensation for damage caused through failure to observe this warning.



### ■ Hazardous substances

This product does not contain substances that exceed the regulation values in the RoHS Directive.



## Safety precautions



The precautions described below are intended to ensure the safe and proper use of the product and to prevent the user and other personnel from exposure to the risk of injury. Use the product only after carefully reading and fully understanding these instructions.

### Description of signs

	Handling the product without observing the instructions that accompany a "WARNING" symbol may result in serious injury or death.
	Handling the product without observing the instructions that accompany a "CAUTION" symbol may result in injury or property damage.
	The items under this heading contain important handling instructions that the user should observe to ensure safe use of the product.



### Description of graphic symbols



	Indicates "prohibited" actions that must not be performed.
	Indicates "compulsory" actions that must be performed.

 <b>WARNING</b>	
	<ul style="list-style-type: none"> <li>Do not use the product in explosive or corrosive environments, in the presence of flammable gases, in areas subjected to splashing water, or near combustible materials. Doing so may result in fire or injury.</li> <li>Do not forcibly bend, pull, or pinch the motor lead wires or cable. Doing so may result in fire.</li> <li>Do not disassemble or modify the product. Doing so may result in injury.</li> <li>Do not use the brake mechanism of the electromagnetic brake motor for braking or as a safety brake. Doing so may result in injury or damage to equipment.</li> </ul>

Thank you for purchasing an Oriental Motor product. This Operating Manual describes product handling procedures and safety precautions.

- Please read the manual thoroughly to ensure safe operation.
- Always keep the manual where it is readily available.

 <b>WARNING</b>	
	<ul style="list-style-type: none"> <li>Assign qualified personnel to the task of installing, wiring, operating, inspecting, and troubleshooting the product. Handling by unqualified personnel may result in fire or injury.</li> <li>When using the product in a vertical drive application such as elevating equipment, be sure to take measures to hold the moving part in position. Failure to do so may result in injury or damage to equipment.</li> <li>Install the product in an enclosure. Failure to do so may result in injury.</li> <li>Connect the product securely according to the connection diagram. Failure to do so may result in fire.</li> <li>Use a DC power supply with reinforced insulation on its primary and secondary sides for a power supply. Failure to do so may result in electric shock.</li> <li>Take measures to hold the moving part in position since the motor will stop and lose its holding torque if an alarm is generated in the driver (any of the driver's protective functions is triggered). Failure to do so may result in injury or damage to equipment.</li> </ul>

 <b>CAUTION</b>	
	<ul style="list-style-type: none"> <li>Do not use the product beyond the specifications. Doing so may result in injury or damage to equipment.</li> <li>Keep fingers and objects out of the openings in the product. Failure to do so may result in fire or injury.</li> <li>Do not touch the product during operation or immediately after stopping. The surface is hot, and this may cause a skin burn(s).</li> <li>Do not lift the motor by holding the output shaft, motor lead wire or cable. Doing so may result in injury.</li> <li>Keep the area around the product free of combustible materials. Failure to do so may result in fire or a skin burn(s).</li> <li>Do not leave anything around the product that would obstruct ventilation. Doing so may result in damage to equipment.</li> <li>Do not touch the rotating part (output shaft) while operating the motor. Doing so may result in injury.</li> </ul>
	<ul style="list-style-type: none"> <li>Provide a cover over the rotating part (output shaft) of the motor. Failure to do so may result in injury.</li> <li>When moving the moving part manually, put the motor in a non-excitation state. Performing work while the motor is in an excitation state may result in injury.</li> <li>Use a motor and driver only in the specified combination. An incorrect combination may cause a fire.</li> <li>Provide an emergency stop device or emergency stop circuit external to the equipment so that the entire system will operate safely in the event of a system failure or malfunction. Failure to do so may result in injury.</li> <li>If any abnormality is observed, stop operation immediately to disconnect power to the driver. Failure to do so may result in fire or injury.</li> </ul>

## CAUTION



- The motor surface temperature may exceed 70 °C (158 °F) even under normal operating conditions. If the operator is allowed to approach the motor during operation, affix a warning label on a conspicuous place as shown in the figure.  
The surface is hot, and this may cause a skin burn(s).



## Precautions for use

- Conduct the insulation resistance measurement or dielectric strength test in a condition where the motor and the driver are disconnected from each other.

Conducting the insulation resistance measurement or the dielectric strength test with the motor and driver connected may result in damage to the product.

- Use the motor in a condition where a radial load and an axial load are equal to or less than the permissible values.

Continuing to operate the motor with a radial load or axial load exceeding the permissible value may cause damage to the bearings (ball bearings). Be sure to operate the motor within the permissible radial load and axial load.

- Use the motor in a condition where its case temperature does not exceed 100 °C (212 °F).

The surface temperature of the motor may exceed 100 °C (212 °F) depending on operating conditions such as ambient temperature, operating speed, operating duty cycle, and others. To prevent the bearings (ball bearings) from reaching the end of their useful life prematurely, use the motor in a condition where the surface temperature of the motor does not exceed 100 °C (212 °F). To protect the encoder, use the motor with encoder in conditions where the surface temperature does not exceed 85 °C (185 °F) for the motor case and 80 °C (176 °F) for the encoder case.

Use the geared motor in a condition where the case temperature of the gear unit does not exceed 70 °C (158 °F) in order to prevent deterioration of grease and parts in the gear unit.

- Holding torque at motor standstill

The holding torque of the motor is reduced by the current cutback function of the driver while the motor is stopped. When selecting a motor, consider the torque reduction while the motor is stopped.

- Do not use the electromagnetic brake for braking the product or as a safety brake.

Do not use the electromagnetic brake as a means to brake and stop the motor. The brake hub of the electromagnetic brake will wear significantly and the braking force will drop. Since the power off activated type electromagnetic brake is equipped, it helps to maintain the position of the load when the power is cut off, but this brake is not a mechanism that will hold the load securely. Accordingly, do not use the electromagnetic brake as a safety brake. To use the electromagnetic brake to hold the load in position, do so after the motor has stopped.

- Maximum torque of geared motor

Always operate geared types with loads not exceeding their maximum torque. If a geared type is operated with a load exceeding the maximum torque, the gear will be damaged.

- Grease of geared motor

On rare occasions, a small amount of grease may ooze out from the geared motor. If there is concern over possible environmental damage resulting from the leakage of grease, check for grease stains during regular inspections. Alternatively, install an oil pan or other device to prevent leakage from causing further damage. Oil leakage may lead to problems in the customer's equipment or products.

- Rotating direction of the gearhead output shaft

Depending on the geared type or the gear ratio, the relationship between the rotation direction of the motor shaft and that of the gearhead output shaft varies as follows.

Geared type	Gear ratio	Rotating direction (Relative to the motor rotation direction)			
		Motor size [mm (in.)]			
		20 (0.79) ø22 (0.87)	28 (1.10) 30 (1.18)	42 (1.65)	60 (2.36)
TH geared	3.6 7.2 10	–	Opposite direction	Same direction	
	20 30	–	Same direction	Opposite direction	
PS geared PN geared	All gear ratio	Same direction			
Harmonic geared		Opposite direction			

## Motors with encoder

- Take measures against static electricity to the encoder.

The encoder uses semiconductor components. Since static electricity may damage semiconductor components, be extremely careful when handling it.

- Do not apply a strong impact to the output shaft or encoder.

Doing so may result in damage to the encoder.

- Do not connect or disconnect the connector while the power is on.

Doing so may result in damage to the encoder.

- Keep the encoder away from a strong magnetic field.

Encoders with **R3G** in the model name, which indicates the encoder resolution, have a built-in magnetic sensor. Installing the motor near equipment that generates a strong magnetic field may affect the angular accuracy of the encoder. Pay attention to the environment for transport and storage or the installation location for use.

## General specifications

Degree of protection	IP20: Motors other than the product models described below IP30: Motors with product models beginning with <b>PK54□AW</b> , <b>PK54□BW</b> , <b>PK56□AW</b> , and <b>PK56□BW</b> *1	
Operating environment	Ambient temperature	–10 to +50 °C (+14 to +122 °F) (non-freezing) *2*3
	Humidity	85 % or less (non-condensing)
	Altitude	Up to 1,000 m (3,300 ft.) above sea level
Storage environment Shipping environment	Surrounding atmosphere	No corrosive gas or dust. No exposure to water or oil.
	Ambient temperature	–20 to +60 °C (–4 to +140 °F) (non-freezing)
	Humidity	85 % or less (non-condensing)
Shipping environment	Altitude	Up to 3,000 m (10,000 ft.) above sea level
	Surrounding atmosphere	No corrosive gas or dust. No exposure to water or oil.
Insulation resistance	100 MΩ or more when 500 VDC megger is applied between the windings and the case.	
Dielectric strength	Sufficient to withstand the following between the windings and the case for 1 minute. <b>PK51</b> , <b>PK52□P</b> , <b>PK54□P</b> : 0.5 kVAC 50/60 Hz <b>PK54</b> : 1.0 kVAC 50/60 Hz <b>PK52□HP</b> , <b>PK56</b> , <b>PK59</b> : 1.5 kVAC 50/60 Hz	

\*1 The box (□) in the product model indicates a number representing the length of the motor case.

\*2 PS geared type [ø22 mm (ø0.87 in.)]: 0 to +50 °C (+32 to +122 °F)

\*3 Harmonic geared type: 0 to +40 °C (+32 to +104 °F)

## Preparation

### ■ Checking the product

Verify that the items listed below are included. Report any missing or damaged items to the sales office from which you purchased the product.

- Motor .....1 unit
- Varistor.....1 piece \*1
- Encoder connection cable [0.6 m (2 ft.)] .....1 piece \*2
- Instructions and Precautions for Safe Use....1 copy

\*1 Electromagnetic brake motor only.

\*2 Motors with encoder for 20 mm (0.79 in.) and 28 mm (1.10 in.) frame sizes only.

### ■ How to identify the product model

#### ● Products other than geared types

**PK 5 1 3 □ P □ A □ □ - R2G L**  
 1 2 3 4 5 6 7 8 9 10 11 12

1	Series	<b>PK: PK Series</b>
2		<b>5: 5-Phase</b>
3	Motor frame size	<b>1:</b> 20 mm (0.79 in.) <b>2:</b> 28 mm (1.10 in.) <b>4:</b> 42 mm (1.65 in.) <b>6:</b> 60 mm (2.36 in.) <b>9:</b> 85 mm (3.35 in.)
4	Motor case length	
5	Motor specification	Blank: Standard specification <b>H:</b> High-speed specification
6	Motor classification	
7	Motor type	Blank: Standard type <b>M:</b> High-resolution type
8	Shaft type	<b>A:</b> Single shaft <b>B:</b> Double shaft
9	Cable type	Blank: Connector coupled type <b>W:</b> Lead wire type
10	Electromagnetic brake	Blank: Without electromagnetic brake <b>M:</b> With electromagnetic brake
11	Encoder resolution	<b>R3G, R2G:</b> 500 P/R
12	Encoder output circuit type	<b>L:</b> Line driver output Blank: Voltage output

#### ● Geared type

**PK 5 2 3 H P A \_ - H 100 S**  
 1 2 3 4 5 6 7 8 9 10 11

1	Series	<b>PK: PK Series</b>
2		<b>5:</b> 5-phase
3	Motor frame size	<b>1:</b> 20 mm (0.79 in.) [ <b>PS</b> geared type is $\varnothing 22$ mm ( $\varnothing 0.87$ in.)] <b>2:</b> 28 mm (1.10 in.) [Harmonic geared type is 30 mm (1.18 in.)] <b>4:</b> 42 mm (1.65 in.) <b>6:</b> 60 mm (2.36 in.)
4	Motor case length	
5	Motor specification	Blank: Standard specification <b>H:</b> High-speed specification
6	Motor classification	
7	Shaft type	<b>A:</b> Single shaft <b>B:</b> Double shaft
8	Motor classification	

9	Geared type	<b>T:</b> TH geared <b>PS:</b> PS geared <b>N:</b> PN geared <b>H:</b> Harmonic geared
10	Gear ratio	
11	Geared classification	

### ■ Names of parts

#### ● Connector coupled type motor

The figure shown below is the standard type (**PK51**).

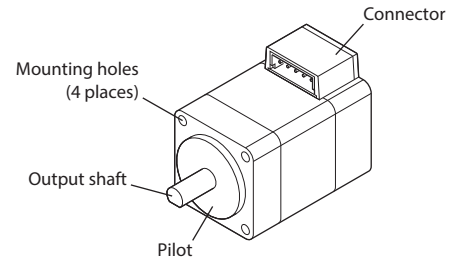

#### ● Lead wire type motor

The figure shown below is the standard type (**PK59**).

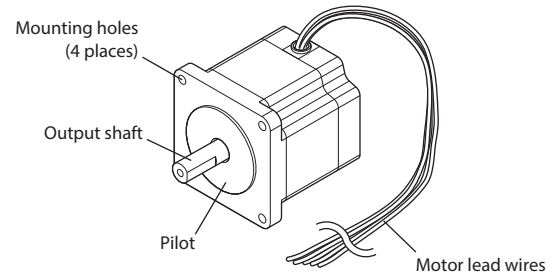

## Installation

### ■ Installation location

The motor is designed and manufactured to be incorporated into equipment. Install it in a well-ventilated location that provides easy access for inspection. The location must also satisfy the following conditions:

- Inside an enclosure installed indoors (provide ventilation holes)
- Operating ambient temperature
  - 10 to +50 °C (+14 to +122 °F) (non-freezing)
  - PS** geared type of  $\varnothing 22$  mm ( $\varnothing 0.87$  in.): 0 to +50 °C (+32 to +122 °F) (non-freezing)
  - Harmonic geared type: 0 to +40 °C (+32 to +104 °F) (non-freezing)
- Operating ambient humidity 85 % or less (non-condensing)
- Area free of explosive atmosphere, toxic gas (such as sulfuric gas), or liquid
- Area not exposed to direct sun
- Area free of excessive amount of dust, iron particles, or the like
- Area not subject to splashing water (rain, water droplets), oil (oil droplets), or other liquids
- Area free of excessive salt
- Area not subject to continuous vibration or excessive shocks
- Area free of excessive electromagnetic noise (from welders, power machinery, etc.)
- Area free of radioactive materials, magnetic fields, or vacuum

## ■ Installation method

The motor can be installed in any direction.

Install the motor on an appropriate flat metal plate with excellent vibration resistance and heat conductivity.

When installing the motor, use four mounting holes to secure the motor with four screws (not included) so that there is no gap between the motor and the metal plate.

### ● Installation method 1

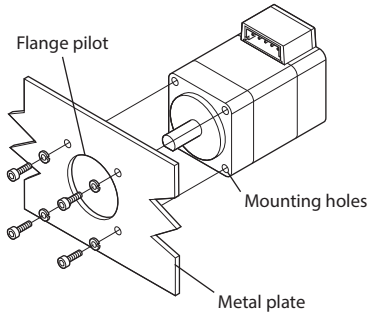

### ● Installation method 2

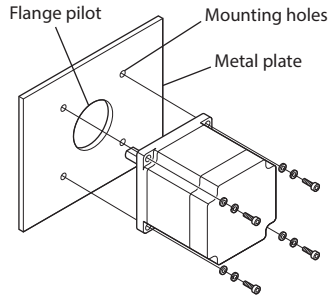

- Insert the pilot located on the motor's installation surface into the pilot holder.
- When installing the motor, do not apply strong force using a hammer or other tools. Doing so may cause damage to the motor.

### ● Screw size, tightening torque, installation method

The value of the tightening torque is recommended. Tighten the screws to an appropriate torque according to the design conditions of the metal plate being installed.

Type	Model	Nominal size	Tightening torque [N·m (oz-in)]	Effective depth of screw thread [mm (in.)]	Installation method
Products other than geared types	PK51	M2	0.25 (2.2)	2.5 (0.1)	1
	PK52	M2.5	0.5 (71)	2.5 (0.098)	
	PK54	M3	1 (142)	4.5 (0.177)	2
	PK56	M4	2 (280)	—	
	PK59	M5	3 (26.6)	—	
TH geared	PK523	M2.5	0.5 (71)	4 (0.157)	1
	PK543	M4	2 (280)	8 (0.315)	
	PK564	M4	2 (280)	8 (0.315)	
PS geared	PK513	M2	0.25 (35)	3.5 (0.138)	1
	PK523	M3	1 (142)	6 (0.236)	
	PK543 PK545	M4	2 (280)	8 (0.315)	
	PK564 PK566	M5	2.5 (350)	10 (0.394)	
PN geared	PK523	M3	1 (142)	6 (0.236)	1
	PK544	M4	2 (280)	8 (0.315)	
	PK564 PK566	M5	2.5 (350)	10 (0.394)	
Harmonic geared	PK513	M2	0.25 (35)	5 (0.197)	1
	PK523	M3	1 (142)	6 (0.236)	
	PK543	M4	2 (280)	8 (0.315)	
	PK564	M5	2.5 (350)	10 (0.394)	

## ■ Installing a load

When installing a load on the motor, align the axis of rotation of the output shaft with that of the load. When installing a coupling or pulley on the motor output shaft, do not damage to the output shaft or the bearing.

### ● Installing on the flange surface (Harmonic geared type)

With a Harmonic geared type, a load can be installed directly to the gear using the load mounting holes provided on the flange surface.

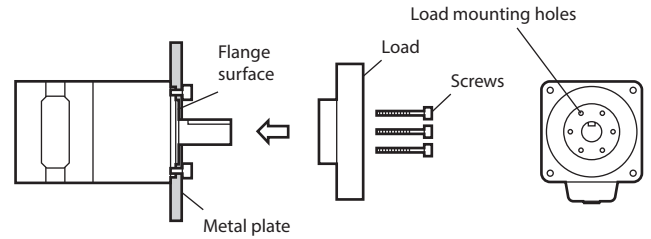

Model	Nominal size	Number of screws	Tightening torque [N·m (oz-in)]	Effective depth of screw thread [mm (in.)]
PK513	M2	3	0.35 (49)	3 (0.118)
PK523	M3	4	1.4 (198)	4 (0.157)
PK543	M3	6	1.4 (198)	5 (0.20)
PK564	M4	6	2.5 (350)	6 (0.236)



- When installing a load on the flange surface, the load cannot also be affixed using the keyway (or milled surface) in the output shaft.
- Design an appropriate installation layout so that the load will not contact the metal plate or screws used for installing the motor.

## ■ Permissible radial load and permissible axial load

Make sure that the radial load and axial load applied to the motor output shaft are equal to or less than the permissible values shown in the table.



The permissible radial load and permissible axial load of the **PS** geared type and **PN** geared type represent the value that the service life of the gear part satisfies 20,000 hours when either of the radial load or axial load is applied to the gear output shaft.

### ● Products other than geared types

Model	Permissible radial load [N (lb.)]					Permissible axial load [N (lb.)]
	Distance from motor output shaft end [mm (in.)]					
	0 (0)	5 (0.20)	10 (0.39)	15 (0.59)	20 (0.79)	
PK51	12 (2.7)	15 (3.3)	—	—	—	3 (0.67)
PK52	25 (5.6)	34 (7.6)	52 (11.7)	—	—	5 (1.12)
PK54	20 (4.5)	25 (5.6)	34 (7.6)	52 (11.7)	—	10 (2.2)
PK56	63 (14.1)	75 (16.8)	95 (21)	130 (29)	190 (42)	20 (4.5)
PK56 *	90 (20)	100 (22)	130 (29)	180 (40)	270 (60)	20 (4.5)
PK59	260 (58)	290 (65)	340 (76)	390 (87)	480 (108)	60 (13.5)

\* High-resolution type only

● TH geared type

Model	Gear ratio	Permissible radial load [N (lb.)]					Permissible axial load [N (lb.)]
		Distance from motor output shaft end [mm (in.)]					
		0 (0)	5 (0.20)	10 (0.39)	15 (0.59)	20 (0.79)	
PK523	All gear ratio	15 (3.3)	17 (3.8)	20 (4.5)	23 (18)	–	10 (2.2)
PK543		10 (2.2)	14 (3.1)	20 (4.5)	30 (6.7)	–	15 (3.3)
PK564		70 (15.7)	80 (18)	100 (22)	120 (27)	150 (33)	40 (9)

● PS geared type

Model	Gear ratio	Permissible radial load [N (lb.)]					Permissible axial load [N (lb.)]
		Distance from motor output shaft end [mm (in.)]					
		0 (0)	5 (0.20)	10 (0.39)	15 (0.59)	20 (0.79)	
PK513	All gear ratio	20 (4.5)	30 (6.7)	–	–	–	20 (4.5)
PK523	All gear ratio	45 (10.1)	60 (13.5)	80 (18)	100 (22)	–	40 (9)
PK545	5	70 (15.7)	80 (18)	95 (21)	120 (27)	–	100 (22)
	7.2	80 (18)	90 (20)	110 (24)	140 (31)	–	
	10	85 (19.1)	100 (22)	120 (27)	150 (33)	–	
PK543	25	120 (27)	140 (31)	170 (38)	210 (47)	–	200 (45)
	36	130 (29)	160 (36)	190 (42)	240 (54)	–	
	50	150 (33)	170 (38)	210 (47)	260 (58)	–	
PK566	5	170 (38)	200 (45)	230 (51)	270 (60)	320 (72)	200 (45)
	7.2	200 (45)	220 (49)	260 (58)	310 (69)	370 (83)	
	10	220 (49)	250 (56)	290 (65)	350 (78)	410 (92)	
PK564	25	300 (67)	340 (76)	400 (90)	470 (105)	560 (126)	200 (45)
	36	340 (76)	380 (85)	450 (101)	530 (119)	630 (141)	
	50	380 (85)	430 (96)	500 (112)	600 (135)	700 (157)	

● PN geared type

Model	Gear ratio	Permissible radial load [N (lb.)]					Permissible axial load [N (lb.)]
		Distance from motor output shaft end [mm (in.)]					
		0 (0)	5 (0.20)	10 (0.39)	15 (0.59)	20 (0.79)	
PK523	All gear ratio	45 (10.1)	60 (13.5)	80 (18)	100 (22)	–	40 (9)
PK544	5	80 (18)	95 (21)	120 (27)	160 (36)	–	100 (22)
	7.2	90 (20)	110 (24)	130 (29)	180 (40)	–	
	10	100 (22)	120 (27)	150 (33)	200 (45)	–	

Model	Gear ratio	Permissible radial load [N (lb.)]					Permissible axial load [N (lb.)]
		Distance from motor output shaft end [mm (in.)]					
		0 (0)	5 (0.20)	10 (0.39)	15 (0.59)	20 (0.79)	
PK566	5	240 (54)	260 (58)	280 (63)	300 (67)	330 (74)	200 (45)
	7.2	270 (60)	290 (65)	310 (69)	340 (76)	370 (83)	
	10	300 (67)	320 (72)	350 (78)	380 (85)	410 (92)	
PK564	25	410 (92)	440 (99)	470 (105)	520 (117)	560 (126)	
	36	360 (81)	410 (92)	480 (108)	570 (128)	640 (144)	
	50	360 (81)	410 (92)	480 (108)	570 (128)	700 (157)	

● Harmonic geared type

Model	Gear ratio	Permissible radial load [N (lb.)]					Permissible axial load [N (lb.)]
		Distance from motor output shaft end [mm (in.)]					
		0 (0)	5 (0.20)	10 (0.39)	15 (0.59)	20 (0.79)	
PK513	All gear ratio	50 (11.2)	75 (16.8)	–	–	–	60 (13.5)
PK523		110 (24)	135 (30)	175 (39)	250 (56)	–	140 (31)
PK543		180 (40)	220 (49)	270 (60)	360 (81)	510 (114)	220 (49)
PK564		320 (72)	370 (83)	440 (99)	550 (123)	720 (162)	450 (101)

● Permissible moment load of the Harmonic geared type

When installing an arm or table on the flange surface, calculate the moment load using the formula below if the flange surface receives any eccentric load. The moment load should not exceed the permissible value specified in the table.

Moment load:  $M [N \cdot m (oz \cdot in)] = F \times L$

Model	Permissible moment load [N·m (oz·in)]
PK513	0.7 (99)
PK523	2.9 (410)
PK543	5.6 (790)
PK564	11.6 (1,640)

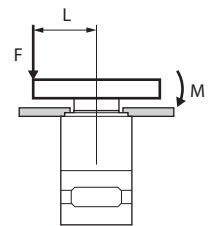

Connection

■ Connector coupled type

Check the connector pin numbers before connecting. The values in parentheses ( ) in the wiring diagram show the wire colors of the Oriental Motor's connection cable. When using the Oriental Motor's connector set or preparing the connector and lead wires by the customer, connect them according to the pin numbers shown in the figure.



- Fix the cables of the connection part of the connector so that the connection part is not stressed by bending the cable or by its own weight. Make the radius of curvature of the cable as large as possible.
- The connector with locking function is used for the connection cable. When removing the cable, release the lock of the connector. Pulling out the connector while it is locked may cause damage to the motor or connector.



When removing the connection cable, remove it horizontally in the direction of the output shaft.

• Pin arrangement

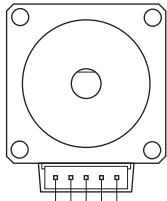

Pin number → 5 4 3 2 1

• Connection diagram

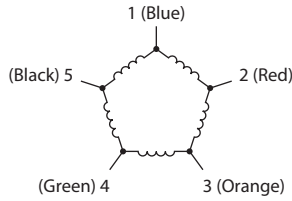

● Applicable connector and lead wire

• PK51, PK52

Manufacturer: Molex, LLC

Connector housing	51065-0500
Contact	50212-8100
Designated crimp tool	57176-5000 or 63819-0500
Applicable lead wire	<ul style="list-style-type: none"> <li>Conductor size: AWG 26 to 24 (0.14 to 0.2 mm<sup>2</sup>)</li> <li>Outer diameter of wire insulation: ø1.4 mm (ø0.055 in.) or less</li> <li>Stripping length of wire insulation: 1.3 to 1.8 mm (0.051 to 0.071 in.)</li> </ul>

• PK54

There are two types of applicable connectors. Use either one shown in the table. Be sure to use a connector housing, contact, and designated crimp tool in the combinations shown in the table.

Applicable connector 1

Manufacturer: Molex, LLC

Connector housing	51103-0500
Contact	50351-8100
Designated crimp tool	57295-5000 or 63811-8100
Applicable lead wire	<ul style="list-style-type: none"> <li>Conductor size: AWG 28 to 22 (0.08 to 0.3 mm<sup>2</sup>)</li> <li>Outer diameter of wire insulation: ø1.15 to 1.8 mm (ø0.045 to 0.071 in.)</li> <li>Stripping length of wire insulation: 2.3 to 2.8 mm (0.091 to 0.11 in.)</li> </ul>

Applicable connector 2

Manufacturer: Molex, LLC

Connector housing	51163-0500
Contact	For AWG 22 to 20: 50752-8200 For AWG 26 to 24: 50752-8400
Designated crimp tool	For AWG 22 to 20: 200218-4900 For AWG 26 to 24: 200218-9200
Applicable lead wire	<ul style="list-style-type: none"> <li>Conductor size: AWG 26 to 20 (0.14 to 0.5 mm<sup>2</sup>)</li> <li>Outer diameter of wire insulation: ø1.15 to 1.8 mm (ø0.045 to 0.071 in.)</li> <li>Stripping length of wire insulation: 2.3 to 2.8 mm (0.091 to 0.11 in.)</li> </ul>

• PK56

Manufacturer: J.S.T. Mfg. Co., Ltd.

Connector housing	VHR-5N
Contact	BVH-21T-P1.1
Designated crimp tool	YC-160R

Applicable lead wire	<ul style="list-style-type: none"> <li>Conductor size: AWG 22 to 18 (0.33 to 0.83 mm<sup>2</sup>)</li> <li>Outer diameter of wire insulation: ø1.7 to 3 mm (ø0.067 to 0.118 in.)</li> <li>Stripping length of wire insulation: 3 to 3.5 mm (0.118 to 0.138 in.)</li> </ul>
----------------------	--

■ Lead wire type

Connect the motor according to the connection diagram. The values in parentheses ( ) in the figure show the colors of the motor lead wires.

Connection diagram

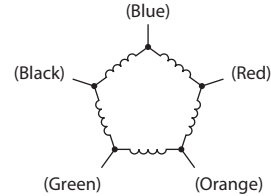

■ Connecting the encoder section

● Pin arrangement

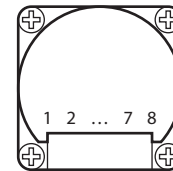

Pin number	Lead wire color*	Signal name		Function
		Line driver output	Voltage output	
1	Black	GND	GND	Power supply input (ground)
2	Red	A+	A	Phase A output positive side
3	Brown	A-	N.C.	Phase A output negative side
4	Green	B+	B	Phase B output positive side
5	Blue	B-	N.C.	Phase B output negative side
6	Yellow	Z+	Z	Phase Z output positive side
7	Orange	Z-	N.C.	Phase Z output negative side
8	White	Vcc	Vcc	Power supply input (+5 V)

\* It indicates the colors of the lead wires for the encoder connection cable of Oriental Motor.

● Applicable connector and lead wire

Manufacturer: Molex, LLC

Connector housing	51021-0800
Contact	50079-8X00
Designated crimp tool	57177-5000 or 200218-1900
Applicable lead wire	<ul style="list-style-type: none"> <li>Conductor size: AWG 28 to 26 (0.08 to 0.128 mm<sup>2</sup>)</li> <li>Outer diameter of wire insulation: ø0.5 to 1.04 mm (ø0.02 to 0.04 in.)</li> <li>Stripping length of wire insulation: 1.4 to 1.9 mm (0.06 to 0.07 in.)</li> </ul>



Use a shielded cable to extend the wiring or reduce the influence of noise. Also, keep the product away from power cables, such as motor or power supply cables, and wire it at the shortest possible distance.

## ● Specifications

Item	Model name indicating the resolution and output circuit type	
	R3GL, R2GL	R3G
Resolution (P/R)	500	
Output type	Incremental	
Output circuit type	Line driver output (Equivalent to 26C31)	Voltage output
Output circuit		
Output signal	Phase A, Phase B, Phase Z: 3 Channels	
Maximum sink current	20 mA	
Output voltage	H level: 2.5 V or more	H level: 4.3 V or more (no load)
	L level: 0.5 V or less	L level: 0.5 V or less
Response frequency	200 kHz or less	100 kHz or less
Power supply voltage	5 VDC±10 %	
Current consumption (no load)	30 mA or less	45 mA or less
Angular accuracy*	±0.36° (conversion value at motor output shaft)	

\* Only when R3 is included in the model name indicating resolution

## ● Output waveform and waveform accuracy (When R3 is included in the model name indicating resolution)

### ● Output waveform

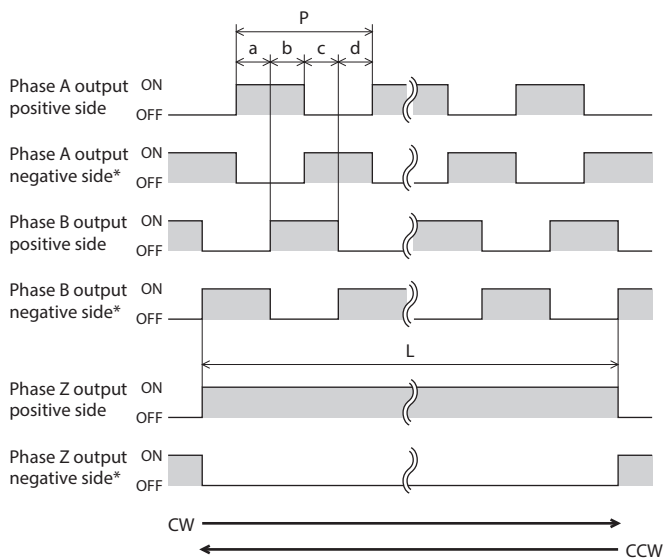

\* Line driver output only

### ● Waveform accuracy

- Duty cycle: 50%±12.5 % for both phase A output and phase B output
  - Phase Z output (standard type):  $L^* = (\text{Encoder resolution}/50) \times P$
  - Phase difference: a, b, c, d =  $P/4 \pm P/8$
  - Rise and fall time of signal: 1 μs or less (at connector terminal)
- \* 7.2° when converted to motor output shaft

## ● Output waveform and waveform accuracy (When R2 is included in the model name indicating resolution)

### ● Output waveform

#### When rotating in the CW direction

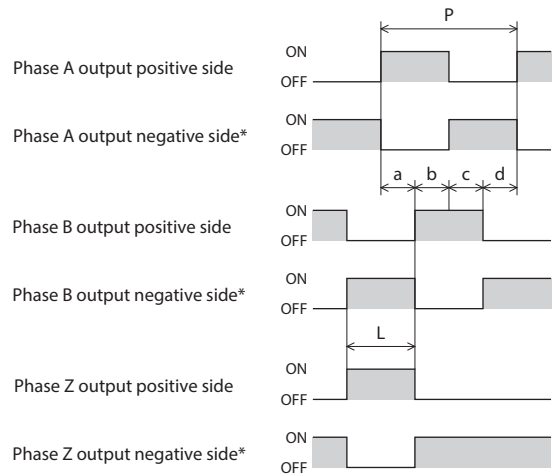

\* Line driver output only

#### When rotating in the CCW direction

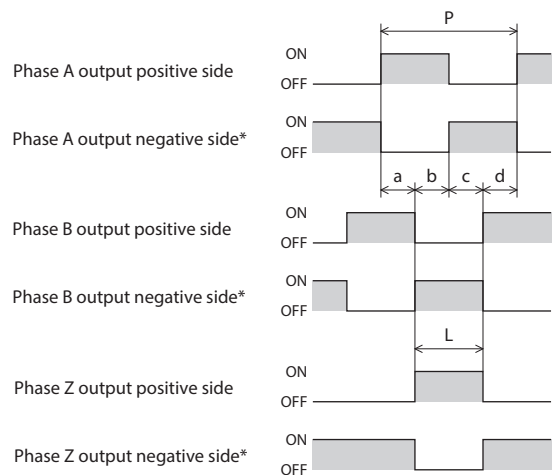

\* Line driver output only

### ● Waveform accuracy

- Duty cycle: 50%±12.5 % for both phase A output and phase B output
- Phase Z output:  $P/4 \leq L \leq 3P/4$
- Phase difference: a, b, c, d =  $P/4 \pm P/8$
- Rise and fall time of signal: 1 μs or less (at connector terminal)

## ■ Connecting the power supply for electromagnetic brake

The electromagnetic brake is operated by turning the DC power supply on and off. For the electromagnetic brake, provide a DC power supply of 24 VDC±5 %, 0.08 A or more for PK54, and 24 VDC±5 %, 0.25 A or more for PK56.

Use a cable thicker than AWG 24 (0.2 mm<sup>2</sup>) to connect the electromagnetic brake and DC power supply, and wire it as short as possible.

## ● Connecting method

Connect the two lead wires (600 mm [23.62 in.]) from the motor to the DC power supply.

1. Connect the Red/White lead wire to the 24 VDC terminal (positive side) and the Black/White lead wire to the ground (GND) terminal (negative side).
2. Connect the included varistor in parallel between the 24 VDC terminal and the ground (GND) terminal.  
The varistor has no polarity.

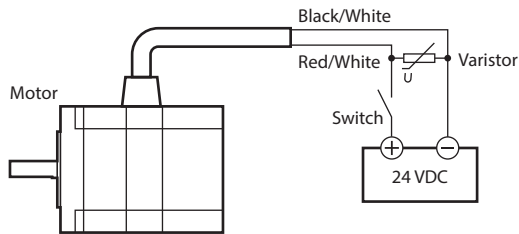

### Note

- Do not apply voltage exceeding the specified value. Doing so may increase the heat generation of the electromagnetic brake, resulting in damage to the motor. On the contrary, too low a voltage may not release the electromagnetic brake.
- Be sure to connect a varistor to protect the contact of the switch and prevent noise.
- Since the electromagnetic brake lead wires have polarity, be sure to connect them with the correct polarity. If the lead wires are connected with reversed polarity, the electromagnetic brake will not operate properly.
- Provide a separate power supply for the I/O signals and the electromagnetic brake.

## ● Operating the electromagnetic brake

Operate the electromagnetic brake as follows.

1. Turn on the power supply of the driver.
2. Put the motor in an excitation state.  
Refer to the operating manual of the driver for how to excite.
3. Before inputting the operation command, turn on the power supply to the electromagnetic brake.  
The electromagnetic brake is released, and the motor will be in a state that can be operated.
4. After motor operations, when holding the load with the electromagnetic brake, make sure that the motor has stopped before turning off the power supply to the electromagnetic brake.

### Note

Activate the electromagnetic brake after the motor has stopped. Also, do not use the electromagnetic brake as a means to brake and stop the motor. Frequent braking and stopping with the electromagnetic brake will significantly wear the brake hub and cause the braking force to drop.

## Inspection and maintenance

### ■ Inspection

It is recommended that the following items be checked periodically after each operation of the motor. If any abnormality occurs, discontinue use of the product and contact your nearest Oriental Motor sales office.

#### ● Inspection items

- Check to see if any of the mounting screws of the motor are loose.
- Check to see if the bearings (ball bearings) of the motor generates unusual noises.
- Check to see if the motor lead wire is not damaged or stressed. Also, check to see if the connection part is loose.
- Check to see if any of the connection parts with the connector or the driver are loose.
- Check to see if the output shaft and the load shaft are not misaligned.

### ■ Warranty

Check on the Oriental Motor Website for the product warranty.

### ■ Disposal

Dispose the product correctly in accordance with laws and regulations, or instructions of local governments.

## Specifications

Check on the Oriental Motor Website for the product specifications.

- Unauthorized reproduction or copying of all or part of this manual is prohibited.
- Oriental Motor shall not be liable whatsoever for any problems relating to industrial property rights arising from use of any information, circuit, equipment or device provided or referenced in this manual.
- Characteristics, specifications and dimensions are subject to change without notice.
- While we make every effort to offer accurate information in the manual, we welcome your input. Should you find unclear descriptions, errors or omissions, please contact the nearest office.
- **Orientalmotor** is a registered trademark or trademark of Oriental Motor Co., Ltd., in Japan and other countries.

© Copyright ORIENTAL MOTOR CO., LTD. 2025

Published in February 2026

- Please contact your nearest Oriental Motor office for further information.

ORIENTAL MOTOR U.S.A. CORP.  
Technical Support Tel:800-468-3982  
8:30am EST to 5:00pm PST (M-F)

ORIENTAL MOTOR (EUROPA) GmbH  
Schiesstraße 44, 40549 Düsseldorf, Germany  
Technical Support Tel:00 800/22 55 66 22

ORIENTAL MOTOR (UK) LTD.  
Blythe Valley Business Park,  
Central Blvd Blythe Valley Park,  
Solihull B90 8AG, United Kingdom  
Tel:+44-1926-671220

ORIENTAL MOTOR (FRANCE) SARL  
Tel:+33-1 47 86 97 50

ORIENTAL MOTOR ITALIA s.r.l.  
Tel:+39-02-93906347

ORIENTAL MOTOR CO., LTD.  
4-8-1 Higashiueno, Taito-ku, Tokyo 110-8536  
Japan  
Tel:+81-3-6744-0361  
www.orientalmotor.co.jp/ja

ORIENTAL MOTOR ASIA PACIFIC PTE. LTD.  
Singapore  
Tel:1800-842-0280

ORIENTAL MOTOR (MALAYSIA) SDN. BHD.  
Tel:1800-806-161

ORIENTAL MOTOR (THAILAND) CO., LTD.  
Tel:1800-888-881

ORIENTAL MOTOR (INDIA) PVT. LTD.  
Tel:1800-120-1995 (For English)  
1800-121-4149 (For Hindi)

TAIWAN ORIENTAL MOTOR CO., LTD.  
Tel:0800-060708

SHANGHAI ORIENTAL MOTOR CO., LTD.  
Tel:400-820-6516

INA ORIENTAL MOTOR CO., LTD.  
Korea  
Tel:080-777-2042