

αSTEP **AZ Series/ Motorized Actuator equipped with AZ Series** EtherCAT Compatible

USER MANUAL

Introduction	
AC power input type	
DC power input type	
EtherCAT communication	
Object list	
Troubleshooting	
Test operation using pulses	
Reference materials	

Thank you for purchasing an Oriental Motor product.
This Manual describes product handling procedures and safety precautions.

- Please read it thoroughly to ensure safe operation.
- Always keep the manual where it is readily available.

Original instructions

1 Introduction

1	Before using the product.....	8
2	Operating manuals	9
2-1	Related operating manuals.....	9
2-2	How to use operating manuals.....	9
3	Overview of the product.....	11
4	Safety precautions	12
4-1	Graphical symbols on the driver's front panel (AC power input driver)	14
4-2	Warning indication (AC power input driver).....	14
5	Precautions for use	15

2 AC power input type

1	System configuration	18
2	Preparation.....	19
2-1	Checking the product	19
2-2	How to identify the product model	19
2-3	Products possible to combine	19
2-4	Information about nameplate	20
2-5	Names and functions of parts	20
2-6	Indication of LEDs.....	22
3	Installation.....	23
3-1	Installation location	23
3-2	Installation method.....	23
4	Connection	25
4-1	Connection example	25
4-2	Connecting the control power supply	26
4-3	Connecting the regeneration resistor	27
4-4	Connecting the main power supply	28
4-5	Grounding the driver.....	29
4-6	Connecting the EtherCAT communication cable.....	29
4-7	Connecting the USB cable.....	30
4-8	Connecting the I/O signals.....	30
4-9	Noise elimination measures.....	36
4-10	Conformity to the EMC Directive/Regulations.....	37
5	Setting of node address.....	39
5-1	Setting method	39
6	Power removal function.....	40
6-1	Safety parameters.....	40
6-2	Notes when using the power removal function.....	41
6-3	I/O signals	41
6-4	Operation of power removal function	42
6-5	Example of use.....	45

6-6	Verification testing of power removal function.....	46
6-7	Related functions.....	46
7	Inspection and maintenance	50
7-1	Inspection.....	50
7-2	Warranty.....	50
7-3	Disposal.....	50
8	Cables	51
8-1	Connection cable (For cable type).....	51
8-2	Connection cables (For connector type).....	54
8-3	I/O signal cable	55
9	Accessories	56
9-1	Pulse signal converter for noise immunity.....	56
9-2	Relay contact protection circuit/module.....	56
9-3	Regeneration resistor	56

3 DC power input type

1	System configuration	58
2	Preparation.....	59
2-1	Checking the product.....	59
2-2	How to identify the product model	59
2-3	Products possible to combine	59
2-4	Information about nameplate	60
2-5	Names and functions of parts.....	60
2-6	Indication of LEDs.....	62
3	Installation.....	63
3-1	Installation location	63
3-2	Installation method.....	63
4	Connection	65
4-1	Connection example	65
4-2	Connecting the control power supply.....	66
4-3	Connecting the main power supply and grounding.....	67
4-4	Connecting the EtherCAT communication cable.....	69
4-5	Connecting the USB cable.....	70
4-6	Connecting the I/O signals.....	70
4-7	Noise elimination measures.....	75
4-8	Conformity to the EMC Directive/Regulations.....	76
5	Setting of node address	78
5-1	Setting method	78
6	Power removal function.....	79
6-1	Safety parameters.....	79
6-2	Notes when using the power removal function.....	80
6-3	I/O signals.....	80
6-4	Operation of power removal function	81
6-5	Example of use.....	84

6-6	Verification testing of power removal function.....	85
6-7	Related functions.....	85
7	Inspection and maintenance	89
7-1	Inspection.....	89
7-2	Warranty.....	89
7-3	Disposal.....	89
8	Cables	90
8-1	Connection cable (For cable type).....	90
8-2	Connection cables (For connector type).....	94
8-3	I/O signal cable	96
9	Accessories	97
9-1	Pulse signal converter for noise immunity.....	97
9-2	Relay contact protection circuit/module.....	97

4 EtherCAT communication

1	Guidance.....	101
2	Communications specifications	104
2-1	EtherCAT communication interface.....	104
2-2	CiA402 drive profile.....	104
2-3	EtherCAT state machine (ESM).....	105
2-4	Process data object (PDO)	105
2-5	Service data object (SDO).....	108
2-6	Synchronous mode of EtherCAT communication.....	109
2-7	Distributed clocks.....	109
2-8	Emergency message.....	109
3	Drive profile.....	110
3-1	Drive state machine	110
3-2	Operation mode.....	113
3-3	Cyclic synchronous position mode (CSP).....	113
3-4	Profile position mode (PP).....	115
3-5	Cyclic synchronous velocity mode (CSV)	126
3-6	Profile velocity mode (PV)	129
3-7	Homing mode (HM)	132
4	Function	146
4-1	Touch probe.....	146
4-2	Resolution.....	150
4-3	Wrap function	151
4-4	Operating current and stop current.....	151
4-5	Maintenance commands	152
4-6	Assignment of I/O function.....	153
5	Position coordinate management	164
5-1	Overview of position coordinate management	164
5-2	Position coordinate origin	168
5-3	Parameters related to ABZO sensor	169

5-4	Mechanism settings parameter.....	170
5-5	Initial coordinate generation & wrap coordinate parameter.....	171
6	Save of parameters	177
7	Object dictionary	178
7-1	Composition of the object dictionary	178
7-2	Objects of the CoE communication area	179
7-3	Objects of the profile area	184
7-4	Objects of the manufacturer-specific area	195

5 Object list

1	Objects of the CoE communication area	201
2	Objects of the profile area	203
3	Objects of the manufacturer-specific area	205

6 Troubleshooting

1	Alarms.....	218
1-1	Alarm reset	218
1-2	Alarm history	218
1-3	Generation condition of alarms.....	218
1-4	Alarm list	219
1-5	Timing chart.....	225
2	Information	227
2-1	Information history	229
2-2	Information list	229
3	Troubleshooting and remedial actions.....	233

7 Test operation using pulses

1	To execute operation by inputting pulses.....	236
1-1	Operation flow	236

8 Reference materials

1	Timing chart	238
2	Specifications	239
2-1	General specifications.....	239
2-2	Product specifications.....	240
3	Regulations and standards.....	242
3-1	UL Standards, CSA Standards	242
3-2	CE Marking / UKCA Marking (AC power input driver)	242
3-3	CE Marking / UKCA Marking (DC power input driver)	244
3-4	Functional safety.....	244

1 Introduction



This part explains the product overview and safety precautions in addition to the types and descriptions about operating manuals.

◆ Table of contents

1	Before using the product	8
2	Operating manuals	9
	2-1 Related operating manuals.....	9
	2-2 How to use operating manuals	9
3	Overview of the product.....	11
4	Safety precautions	12
	4-1 Graphical symbols on the driver's front panel (AC power input driver).....	14
	4-2 Warning indication (AC power input driver)	14
5	Precautions for use.....	15

1 Before using the product

Only qualified personnel of electrical and mechanical engineering should work with the product.

Use the product correctly after thoroughly reading the section "4 Safety precautions" on p.12. In addition, be sure to observe the contents described in warning, caution, and note in this manual.

The product described in this manual is designed and manufactured to be incorporated in general industrial equipment. Do not use for any other purpose. Oriental Motor Co., Ltd. is not responsible for any compensation for damage caused through failure to observe this warning.

2 Operating manuals

2-1 Related operating manuals

For operating manuals, download from Oriental Motor Website Download Page or contact your nearest Oriental Motor sales office.

- **AZ** Series/Motorized Actuator equipped with **AZ** Series EtherCAT Compatible USER MANUAL (this document)
- **AZ** Series/Motorized Actuator equipped with **AZ** Series OPERATING MANUAL Function Edition

Read the following operating manuals for motors and motorized actuators.

- OPERATING MANUAL Motor Edition
- OPERATING MANUAL Actuator Edition
- Motorized Actuator OPERATING MANUAL Function Setting Edition

2-2 How to use operating manuals

To use the product, read this manual together with the **AZ** Series OPERATING MANUAL Function Edition. This manual describes contents specific to the EtherCAT Compatible driver, and the **AZ** Series OPERATING MANUAL Function Edition describes contents common to the **AZ** Series products. Refer to the **AZ** Series OPERATING MANUAL Function Edition for the contents not included in this manual. Reference destinations are indicated according to the flow of use.

■ How to read reference destinations

The title name of the operating manual is described in the reference destination.



The title number described in the reference destination may be changed. Use the title name when checking the reference destination.

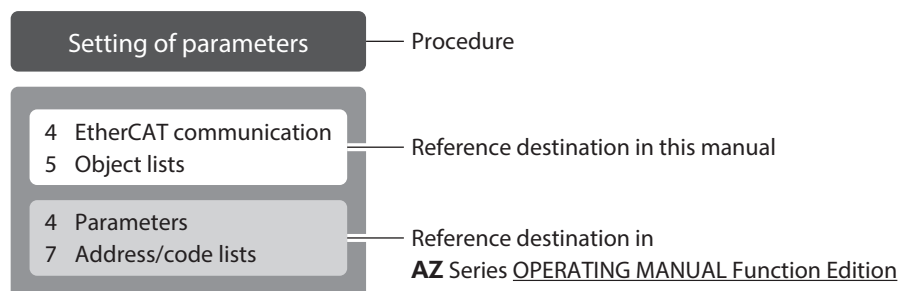

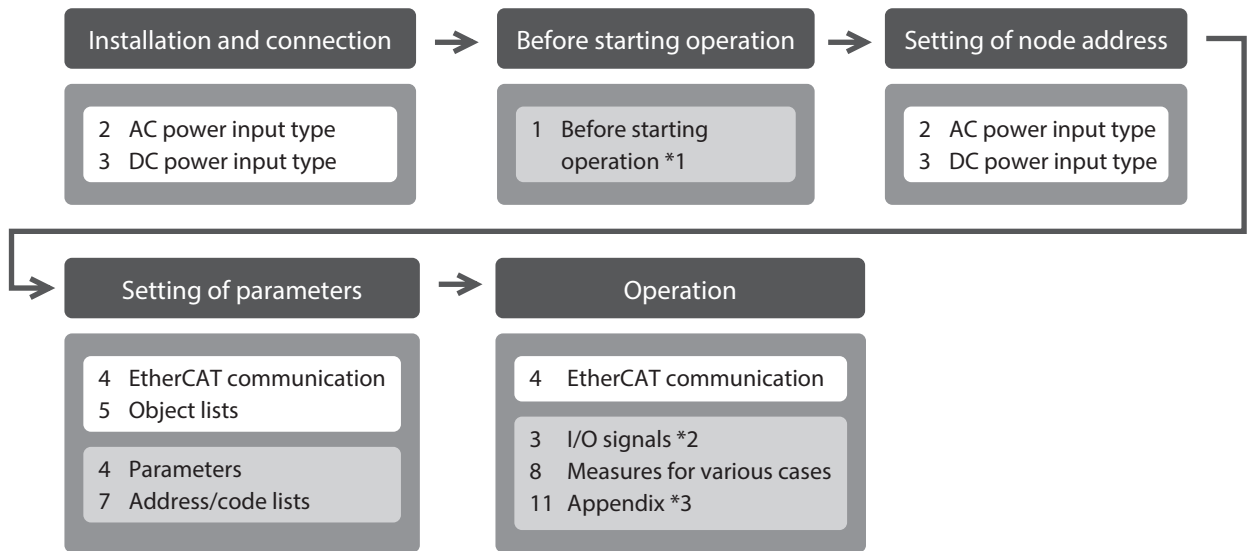

*1 When a motorized actuator is used, the following contents cannot be operated via EtherCAT communication. Use the support software **MEXE02**.

- Copying the fixed value (parameter) of the ABZO sensor to a driver
- Creation of recovery data file and method of recovery

*2 Refer to this manual for “power removal function.”

- When the AC power input driver is used: p.40
- When the DC power input driver is used: p.79

*3 Refer to this manual for “LEDs of the driver.”

- When the AC power input driver is used: p.22
- When the DC power input driver is used: p.62

■ About notation of objects

In this manual, the index number is described in parentheses () after the object name.

Example: Controlword (6040h)

3 Overview of the product

The **AZ** Series EtherCAT Compatible driver is the dedicated driver for the **AZ** Series products.

■ Lineup

Two types of the **AZ** Series EtherCAT Compatible drivers are available: AC power input type and DC power input type.

■ Setting methods of parameters

Parameters can be set via EtherCAT communication or using the **MEXE02**.
This manual describes how to set parameters via EtherCAT communication.

■ Equipped with power removal function





The power removal function is a function that stops supplying the power to the motor by the hardware. The power removal function is assumed to be used to prevent unexpected starting of the moving parts of equipment when an operator works inside the operating range of the moving parts.

■ Providing the ESI file

The ESI file (EtherCAT SubDevice Information file) is the one that describes the specific information of the EtherCAT SubDevice products in XML format. By importing the ESI file to the EtherCAT Configuration Tool of the PLC (programmable controller), the settings of EtherCAT communication can be performed before you receive the driver. For details, contact your nearest Oriental Motor sales office.

4 Safety precautions

The precautions described below are intended to ensure the safe and correct use of the product, and to prevent the customer and others from exposure to the risk of injury. Use the product only after carefully reading and fully understanding these instructions.

 WARNING	Handling the product without observing the instructions that accompany a "WARNING" symbol may result in serious injury or death.
 CAUTION	Handling the product without observing the instructions that accompany a "CAUTION" symbol may result in injury or property damage.
	The items under this heading contain important handling instructions that the user should observe to ensure the safe use of the product.
	The items under this heading contain related information and contents to gain a further understanding of the text in this manual.

WARNING

■ Common to AC power input driver and DC power input driver

General

- Do not use the driver in explosive or corrosive environments, in the presence of flammable gases, in places subjected to splashing water, or near combustibles. Doing so may result in fire, electric shock, or injury.
- Assign qualified personnel to the task of installing, wiring, operating/controlling, inspecting, and troubleshooting the driver. Handling by unqualified personnel may result in fire, electric shock, injury, or damage to equipment.
- Do not transport, install, connect, or inspect the driver while the power is supplied. Doing so may result in electric shock.
- Do not touch the driver while the power is supplied. Doing so may result in fire or electric shock.
- Take measures to keep the moving part in position if the product is used in vertical operations such as elevating equipment. Failure to do so may result in injury or damage to equipment.
- When an alarm is generated in the driver (any of the driver's protective functions is triggered), remove the cause before clearing the alarm (protective function). Continuing the operation without removing the cause of the problem may cause malfunction of the motor and the driver, leading to injury or damage to equipment.

Installation

- Install the driver inside an enclosure. Failure to do so may result in electric shock or injury.

Connection

- Always keep the power supply voltage of the driver within the specified range. Failure to do so may result in fire or electric shock.
- Connect the product securely according to the wiring diagram. Failure to do so may result in fire or electric shock.
- Do not forcibly bend, pull, or pinch the cable. Doing so may result in fire or electric shock.

Operation



- Turn off the main power supply and the control power supply in the event of a power failure. Failure to do so may result in injury or damage to equipment.
- Take safety measures in the event of a momentary voltage drop. Failure to do so may cause the motor to stop or reduce the holding force or rotational torque, resulting in injury or damage to equipment.
- Do not remove the motor excitation during operation. Doing so may cause the motor to stop and lose the holding force, resulting in injury or damage to equipment.

Repair, disassembly, and modification

- Do not disassemble or modify the driver. Doing so may result in injury or damage to equipment.

■ AC power input driver

General

- Do not touch the terminals indicated   signs on the driver's front panel while the power is supplied because high voltage is applied. Doing so may result in fire or electric shock.

Installation

- Be sure to ground the driver as it is Class I equipment. Failure to do so may result in electric shock.

Inspection and maintenance

- Do not touch the connection terminals of the driver immediately after turning off the main power supply and the control power supply. Before performing connection or inspection, turn off the main power supply and the control power supply, and check the CHARGE LED has been turned off. The residual voltage may cause electric shock.

CAUTION

■ Common to AC power input driver and DC power input driver

General

- Do not use the driver beyond its specifications. Doing so may result in electric shock, injury, or damage to equipment.
- Keep your fingers and objects out of the openings in the driver. Failure to do so may result in fire, electric shock, or injury.
- Do not touch the driver during operation or immediately after stopping. Doing so may result in a skin burn(s).
- Do not forcibly bend or pull the cable that is connected to the driver. Doing so may result in damage.

Installation

- Keep the area around the driver free of combustible materials. Failure to do so may result in fire or a skin burn(s).
- Do not leave anything around the driver that would obstruct ventilation. Doing so may result in damage to equipment.

Operation

- Use a motor and a driver only in the specified combination. An incorrect combination may cause a fire.
- Provide an emergency stop device or emergency stop circuit external to the equipment so that the entire equipment will operate safely in the event of a system failure or malfunction. Failure to do so may result in injury.
- Before turning on the main power supply and the control power supply, turn all input signals to the driver to OFF. Failure to do so may result in injury or damage to equipment.
- When moving the moving part manually, put the motor into a non-excitation state. Continuing the work while the motor is in an excitation state may result in injury.
- When an abnormal condition has occurred, immediately stop operation to turn off the main power supply and the control power supply. Failure to do so may result in fire, electrical shock, or injury.
- Take measures against static electricity when operating the switches of the driver. Failure to do so may result in the driver malfunction or damage to equipment.

Inspection and maintenance

- Do not touch the terminals while conducting the insulation resistance measurement or the dielectric strength test. Doing so may result in electric shock.

■ AC power input driver

Operation



- For the control power supply, use a DC power supply with reinforced insulation on its primary and secondary sides. Failure to do so may result in electric shock.

■ DC power input driver

Operation

- For the main power supply and the control power supply, use a DC power supply with reinforced insulation on its primary and secondary sides. Failure to do so may result in electric shock.

4-1 Graphical symbols on the driver's front panel (AC power input driver)

	<p>⚠ WARNING This is the Protective Earth Terminal. Be sure to ground because improper grounding may result in electric shock.</p>
	<p>⚠ WARNING A high voltage is applied to the motor connector (CN3) and the main power supply input terminals (CN4). Do not touch them while the power is supplied. Doing so may result in fire or electric shock.</p>

4-2 Warning indication (AC power input driver)

A warning about handling precautions is described on the driver. Be sure to observe the description contents when handling the product.

Electrical hazard warning label

⚠ WARNING – Risk of electric shock.

- Read manual before installing. (Multiple rated)
- Do not touch the driver immediately after the power is cut off, or until the CHARGE LED (lit in red) turns off. Doing so may result in electric shock due to residual voltage.

⚠ AVERTISSEMENT – Risque de décharge électrique.

- Lire le manuel avant l'installation.
- Ne pas toucher au variateur immédiatement après la mise hors tension ou avant que la LED "présence de la tension" (Rouge) ne soit éteinte. Le non respect de ces règles pourrait entraîner un choc électrique.

⚠ 警告 – けが・感電のおそれがあります。

- 据え付け、運転の前には必ず取扱説明書をお読み下さい。
- 電源を切った直後、CHARGE LED(赤色点灯)が消灯するまでドライバに触れないで下さい。残留電圧により感電の原因になります。

Material: PET

5 Precautions for use

This chapter covers restrictions and requirements the user should consider when using the product.

■ Common to AC power input driver and DC power input driver

● Be sure to use our cable to connect the motor and the driver.

Check the cable models on p.51 (AC power input driver) or p.90 (DC power input driver).

● When conducting the insulation resistance measurement or the dielectric strength test, be sure to separate the connection between the motor and the driver.

Conducting the insulation resistance measurement or dielectric strength test with the motor and the driver connected may result in damage to the product.

● Note on connecting a power supply whose positive terminal is grounded

The USB communication connector and CN7 connector on the driver are not electrically insulated. When grounding the positive terminal of the power supply, do not connect any equipment (PC, etc.) whose negative terminal is grounded. Doing so may cause the driver and this equipment to short, damaging both. When connecting, do not ground equipment.

● Saving data to the non-volatile memory

Do not turn off the control power supply while writing the data to the non-volatile memory, and also do not turn off for 5 seconds after the completion of writing the data. Doing so may abort writing the data and cause an alarm of EEPROM error to generate. The non-volatile memory can be rewritten approximately 100,000 times.

● Noise elimination measures

Refer to p.36 (AC power input driver) or p.75 (DC power input driver) for the noise elimination measures.

■ AC power input driver

● Preventing leakage current

Stray capacitance exists between the driver's current-carrying line and other current-carrying lines, the earth and the motor, respectively. A high-frequency current may leak out through such capacitance, having a detrimental effect on the surrounding equipment. The actual leakage current depends on the driver's switching frequency, the length of wiring between the driver and the motor, and so on. When installing an earth leakage breaker, use a product offering resistance against high frequency current such as the one specified below.

Mitsubishi Electric Corporation: NV series

● If vertical drive (gravitational operation) such as elevator applications is performed or if sudden start-stop operation of a large inertia is repeated frequently, connect our regeneration resistor RGB100.

An alarm of overvoltage may be detected depending on the operating condition of the motor. When the alarm of overvoltage has been detected, reconsider the operating condition or use our regeneration resistor **RGB100**. Refer to p.27 for the connection method.

2 AC power input type

This part explains contents specific to the AC power input type driver.

◆Table of contents

1	System configuration.....	18	6	Power removal function.....	40
2	Preparation	19	6-1	Safety parameters.....	40
2-1	Checking the product	19	6-2	Notes when using the power removal function.....	41
2-2	How to identify the product model	19	6-3	I/O signals	41
2-3	Products possible to combine	19	6-4	Operation of power removal function	42
2-4	Information about nameplate	20	6-5	Example of use.....	45
2-5	Names and functions of parts.....	20	6-6	Verification testing of power removal function.....	46
2-6	Indication of LEDs.....	22	6-7	Related functions.....	46
3	Installation	23	7	Inspection and maintenance	50
3-1	Installation location	23	7-1	Inspection.....	50
3-2	Installation method	23	7-2	Warranty.....	50
4	Connection	25	7-3	Disposal.....	50
4-1	Connection example	25	8	Cables	51
4-2	Connecting the control power supply	26	8-1	Connection cable (For cable type)	51
4-3	Connecting the regeneration resistor.....	27	8-2	Connection cables (For connector type).....	54
4-4	Connecting the main power supply	28	8-3	I/O signal cable.....	55
4-5	Grounding the driver.....	29	9	Accessories.....	56
4-6	Connecting the EtherCAT communication cable	29	9-1	Pulse signal converter for noise immunity	56
4-7	Connecting the USB cable.....	30	9-2	Relay contact protection circuit/module	56
4-8	Connecting the I/O signals.....	30	9-3	Regeneration resistor	56
4-9	Noise elimination measures	36			
4-10	Conformity to the EMC Directive/Regulations	37			
5	Setting of node address	39			
5-1	Setting method	39			

1 System configuration

The figure shows an example when the cable type electromagnetic brake motor with single-phase 200-240 VAC input is used.

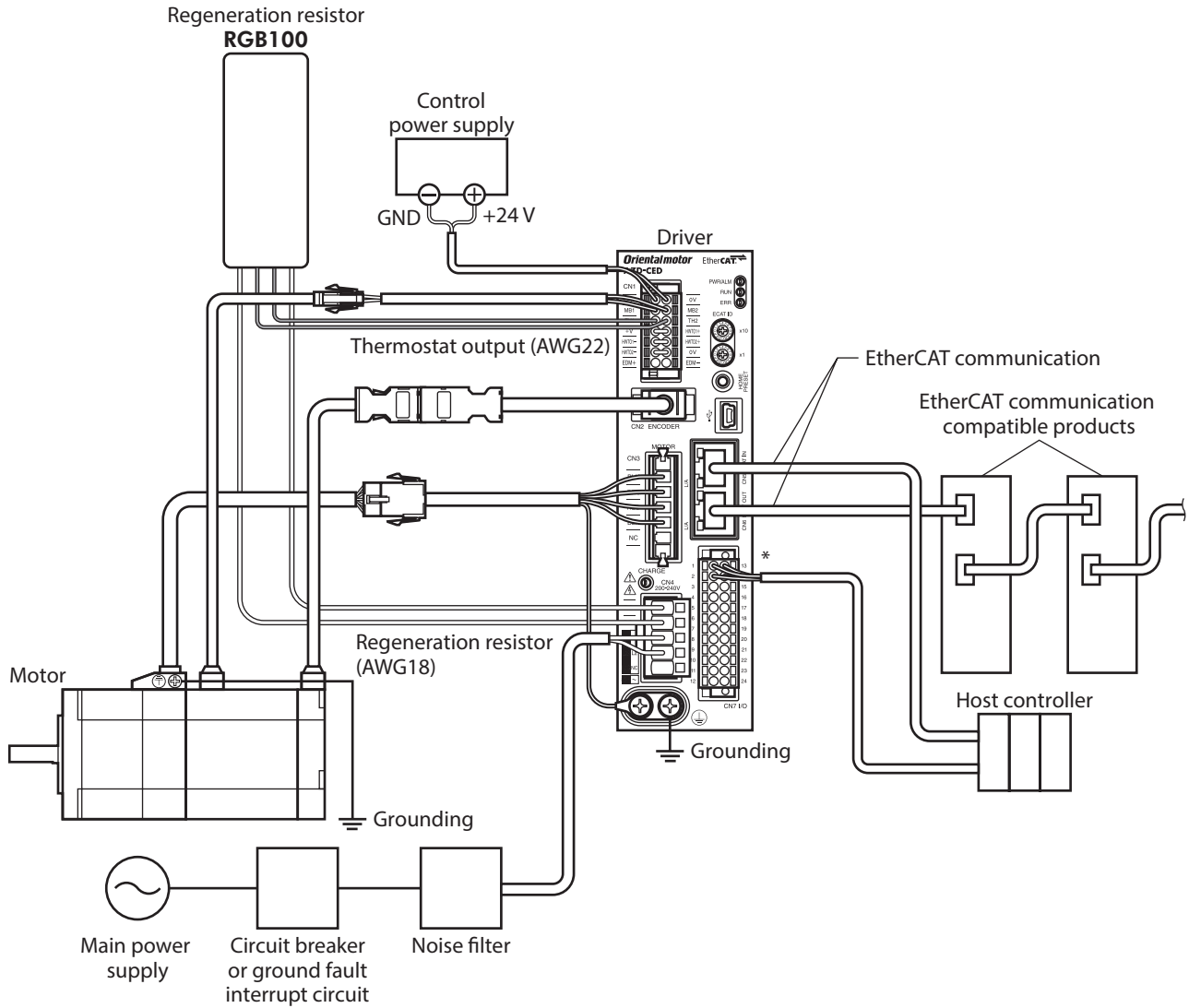

* Connect when using direct I/O or sensors.

2 Preparation

This chapter explains the items you should check, as well as names and functions of each part.

2-1 Checking the product

Verify that the items listed below are included. Report any missing or damaged items to the Oriental Motor sales office from which you purchased the product.

- Driver 1 unit
- CN1 connector (14 pins) 1 pc.
- CN4 connector (5 pins) 1 pc.
- CN7 connector (24 pins) 1 pc.
- Connector lever..... 1 pc. (for CN4 connector)
- Instructions and Precautions for Safe Use 1 copy

Included connector model

Type	Part number	Manufacturer
CN1 connector	DFMC1,5/7-ST-3,5-LR	PHOENIX CONTACT GmbH & Co. KG
CN4 connector	05JFAT-SAXGDK-H5.0	J.S.T. Mfg. Co., Ltd.
CN7 connector	DFMC1,5/12-ST-3,5	PHOENIX CONTACT GmbH & Co. KG

2-2 How to identify the product model

Check the model name of the driver against the number shown on the nameplate. Refer to p.20 for how to identify the nameplate.

AZD - C ED

1 2 3

1	Series	AZD: AZ Series driver
2	Power supply input	A: Single-phase 100-120 VAC C: Single-phase/Three-phase 200-240 VAC
3	Network type	ED: EtherCAT Compatible

2-3 Products possible to combine

Products with which the driver can be combined are listed below. Check the model name of the product with the nameplate.

Power supply type	Product type	Applicable series	Model name representing series name *1	Example of model name
AC input	Stepping motor	AZ Series	AZM	AZM46AC AZM66AC-TS10
		EAS Series *2	EASM	EASM4NXD005AZAC
	Motorized actuator	EAC Series *2	EACM	EACM4RWE15AZMC
		EZS Series *2	EZSM	EZSM6D005AZAC
		EZSH Series *2	EZSHM	EZSHM6H020AZAC
		DGII Series	DGM DGB	DGM85R-AZAC DGB85R12-AZACR
		L Series	LM	LM4F500AZMC-10

*1 The driver described in this manual can be combined with products that begin with these model names.

*2 For these motorized actuators, the equipped motors have been evaluated to affix the CE Marking. Check the model name of the equipped motor with the nameplate.

2-4 Information about nameplate

The figure shows an example.

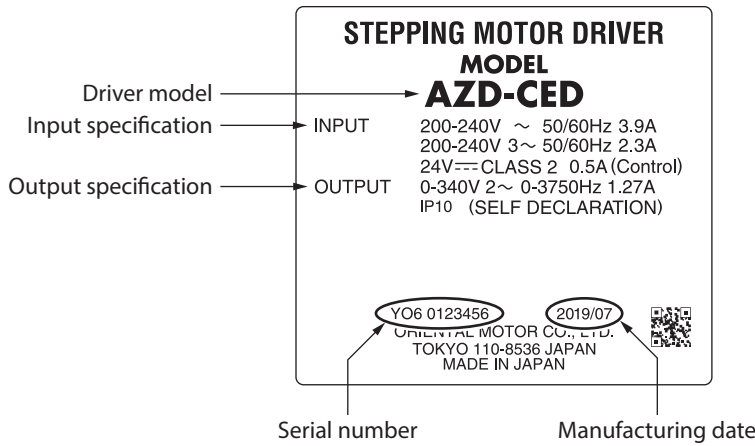



memo The position describing the information may vary depending on the product.

2-5 Names and functions of parts

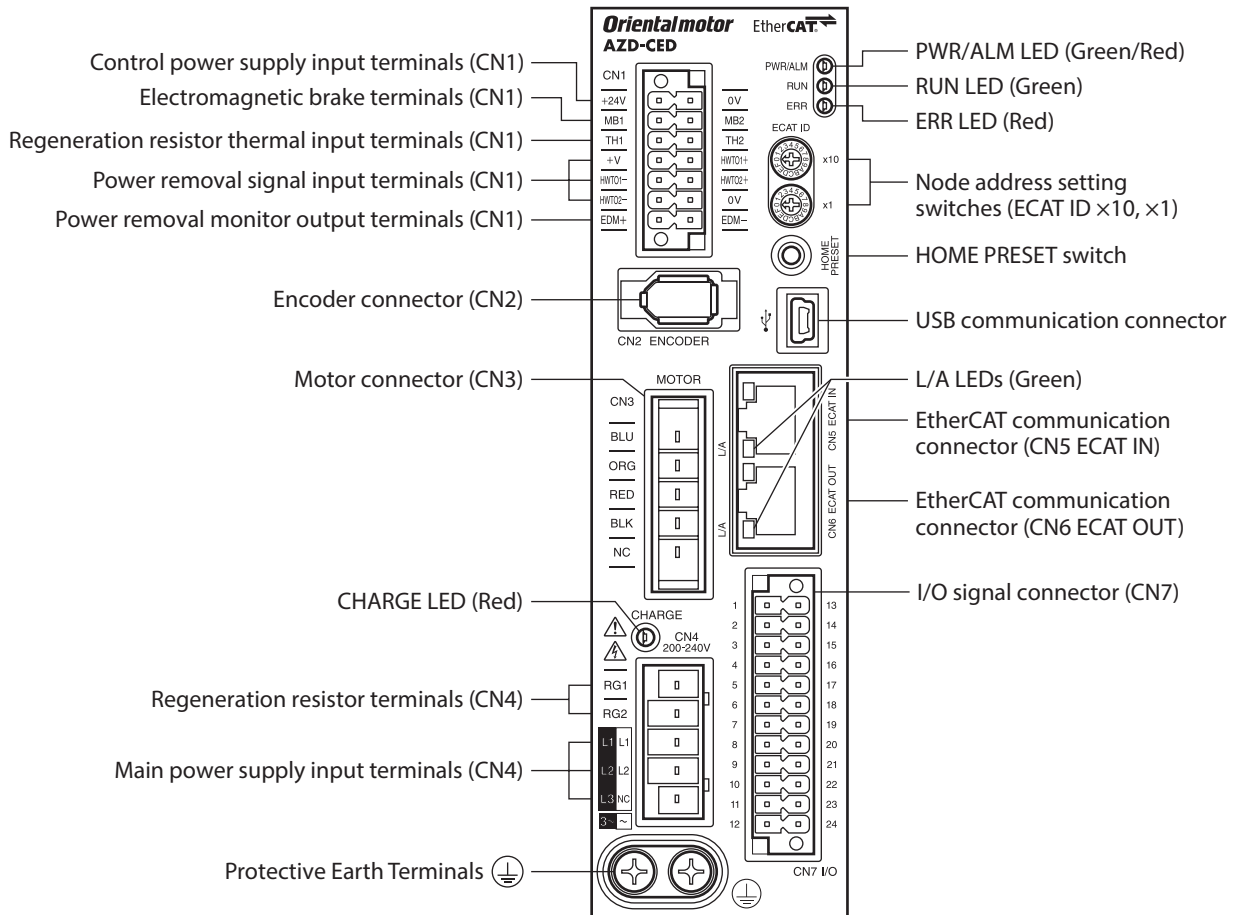
The figure shows the **AZD-CED**.



Type	Name	Sign	Description
LED	CHARGE LED (Red)	CHARGE	This LED is lit while the main power supply is turned on. After the main power has been turned off, the LED will turn off once the residual voltage in the driver drops to a safe level.
	PWR/ALM LED (Green/Red)	PWR/ALM	<ul style="list-style-type: none"> This LED is lit in green while the control power supply is turned on. If an alarm (protective function) is generated, the LED will blink in red. If the power removal function (p.40) is triggered, the LED will blink in green. If information is generated, the LED will simultaneously blink in green and red twice. (Green and red colors may overlap and it may be visible to orange.)
	RUN LED (Green)	RUN	This LED indicates the status of EtherCAT communication.
	ERR LED (Red)	ERR	This LED blinks when an error occurred via EtherCAT communication.
	L/A LEDs (Green)	L/A	These LEDs indicate the LINK/ACT status of EtherCAT communication.
Switch	Node address setting switches	ECAT ID ×10 ECAT ID ×1	Used to set the node address. Factory setting: 00 (×10: 0, ×1: 0)
	HOME PRESET switch	HOME PRESET	Used to set the starting position (home) when positioning operation is performed.
Connector	Encoder connector (CN2)	ENCODER	Connects the encoder.
	Motor connector (CN3)	MOTOR	Connects the motor.
	USB communication connector		Connects a PC in which the MEXE02 has been installed. (USB2.0 mini-B port)
	EtherCAT communication connector (CN5)	ECAT IN	Connects with the upper EtherCAT communication compatible product.
	EtherCAT communication connector (CN6)	ECAT OUT	Connects with the EtherCAT communication compatible product of the following node address.
	I/O signal connector (CN7)	I/O	Connects when using direct I/O or sensors.
Terminal	Control power supply input terminals (CN1)	+24V, 0V	Connects the control power supply.
	Electromagnetic brake terminals (CN1)	MB1, MB2	Connects the lead wires from the electromagnetic brake.
	Regeneration resistor thermal input terminals (CN1)	TH1, TH2	Connects our regeneration resistor RGB100 . If the regeneration resistor RGB100 is not connected, short the TH1 and TH2 terminals.
	Power removal signal input terminals (CN1)	HWT01+, HWT01– HWT02+, HWT02–	Connects the external device.
	Power removal monitor output terminals (CN1)	EDM+, EDM–	
	Regeneration resistor terminals (CN4)	RG1, RG2	Connects our regeneration resistor RGB100 .
	Main power supply input terminals (CN4)	L, N, NC L1, L2, NC L1, L2, L3	Connects the main power supply.
Protective Earth Terminals		Ground using a grounding wire of AWG16 to 14 (1.25 to 2.0 mm ²).	

2-6 Indication of LEDs

■ LED indication related to driver status

PWR/ALM LED status		Description
Green	Red	
Unlit	Unlit	The control power supply is not turned on.
Lit	Unlit	The control power supply is turned on.
Unlit	Blinking	An alarm is being generated. Details about the generated alarm can be checked by counting the number of times the LED blinks. The LED is lit in green when the alarm is reset.
Blinking	Unlit	The power removal function has been activated. After the power removal function is released, the LED is lit in green when the ETO-CLR input is turned ON.
Blinking twice at the same time *		<ul style="list-style-type: none"> Information is being generated. The LED is lit in green when the information is cleared. Remote operation is being executed with the MEXE02. The LED is lit in green when remote operation is complete.
Blinking at the same time *		The interlock was released by holding down the HOME PRESET switch. The LED is lit in green when the time set in the "Extended input (EXT-IN) interlock releasing duration (4973h)" is elapsed.
Lit at the same time *		The input signal assigned to the HOME PRESET switch is being executed. The LED is lit in green when it is complete.
Repeating "Green → Red → Simultaneously lit → Unlit"		This is the driver simulation mode.

* Green and red colors may overlap and it may be visible to orange.

■ LED indication related to EtherCAT communication status

LED indicator	LED status	Description
RUN (Green)	Unlit	Initialization state
	Blinking *	Pre-Operational state
	Single flash *	Safe-Operational state
	Lit	Operational state (normal condition)
ERR (Red)	Unlit	No communication error
	Blinking *	Communication setting error
	Single flash *	Communication data error
	Double flash *	Communication watchdog timeout
L/A (Green)	Unlit	No link
	Lit	Link establishment
	Flickering *	Operation in progress after link establishment

* The timing to blink the LED is as follows. (unit: ms)

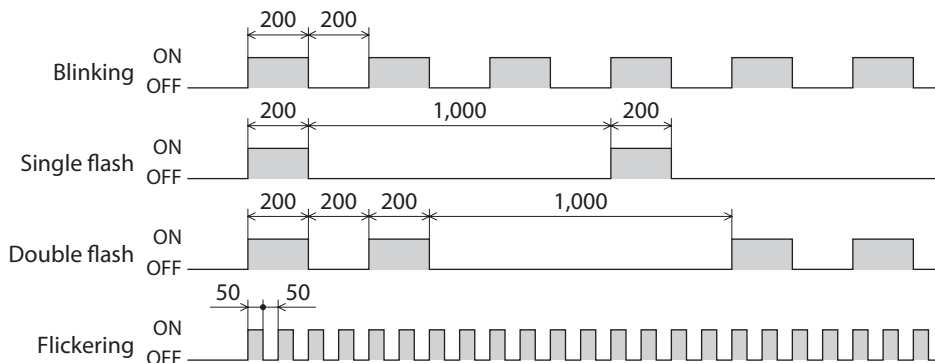

3 Installation

This chapter explains the installation location and installation method of the driver.

3-1 Installation location

The driver is designed and manufactured to be incorporated in equipment. Install it in a well-ventilated location that provides easy access for inspection. The location must also satisfy the following conditions:

- Inside an enclosure that is installed indoors (provide vent holes)
- Operating ambient temperature: 0 to +55 °C (+32 to +131 °F) (non-freezing)
- Operating ambient humidity: 85 % or less (non-condensing)
- Area free of explosive atmosphere, toxic gas (such as sulfuric gas), or liquid
- Area not exposed to direct sun
- Area free of excessive amount of dust, iron particles or the like
- Area not subject to splashing water (rain, water droplets), oil (oil droplets), or other liquids
- Area free of excessive salt
- Area not subject to continuous vibrations or excessive shocks
- Area free of excessive electromagnetic noise (from welders, power machinery, etc.)
- Area free of radioactive materials, magnetic fields or vacuum
- Up to 1,000 m (3,300 ft.) above sea level

3-2 Installation method

The driver is designed so that heat is dissipated via air convection and conduction through the enclosure. Install the driver to a flat metal plate [material: aluminum, 200×200×2 mm (7.87×7.87×0.08 in.) or equivalent] offering high heat conductivity. When installing drivers, provide clearances of at least 25 mm (0.98 in.) in the horizontal and vertical directions between the driver and enclosure or other equipment within the enclosure.

When installing the driver, use two screws (M4, not included) to secure the driver through the mounting holes.

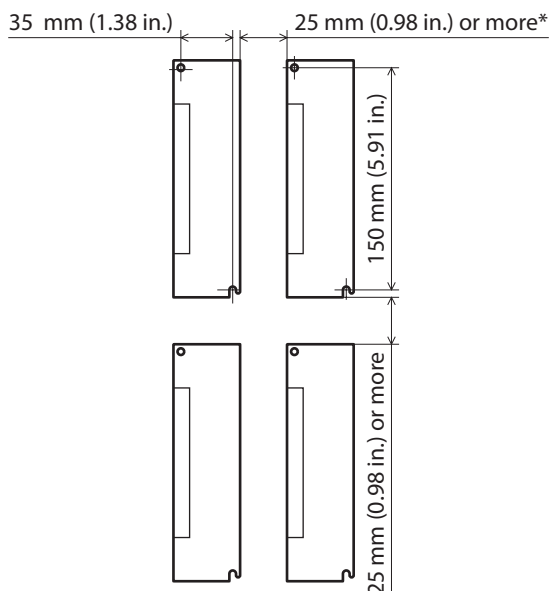

* The drivers can be installed closely in the horizontal direction when the following conditions are satisfied.

- Metal plate [material: aluminum, 350×350×2 mm (13.78×13.78×0.08 in.) or equivalent]
- Ambient temperature: 0 to +40 °C (+32 to +104 °F)

Possible to install closely

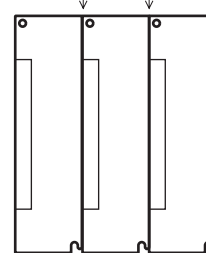

Note

- Install the driver in an enclosure whose degree of protection is IP54 minimum when used in a pollution degree 3 environment.
- Do not install any equipment that generates a large amount of heat or noise near the driver.
- Do not install the driver underneath the host controller or other equipment vulnerable to heat.
- If the ambient temperature of the driver exceeds 55 °C (131 °F), reconsider the ventilation condition such as providing forced cooling by using fans or creating spaces between the drivers.
- Be sure to install the driver vertically (in vertical position).

■ **Dimensions**

- Unit: mm (in.)
- Mass: 0.68 kg (1.5 lb.)

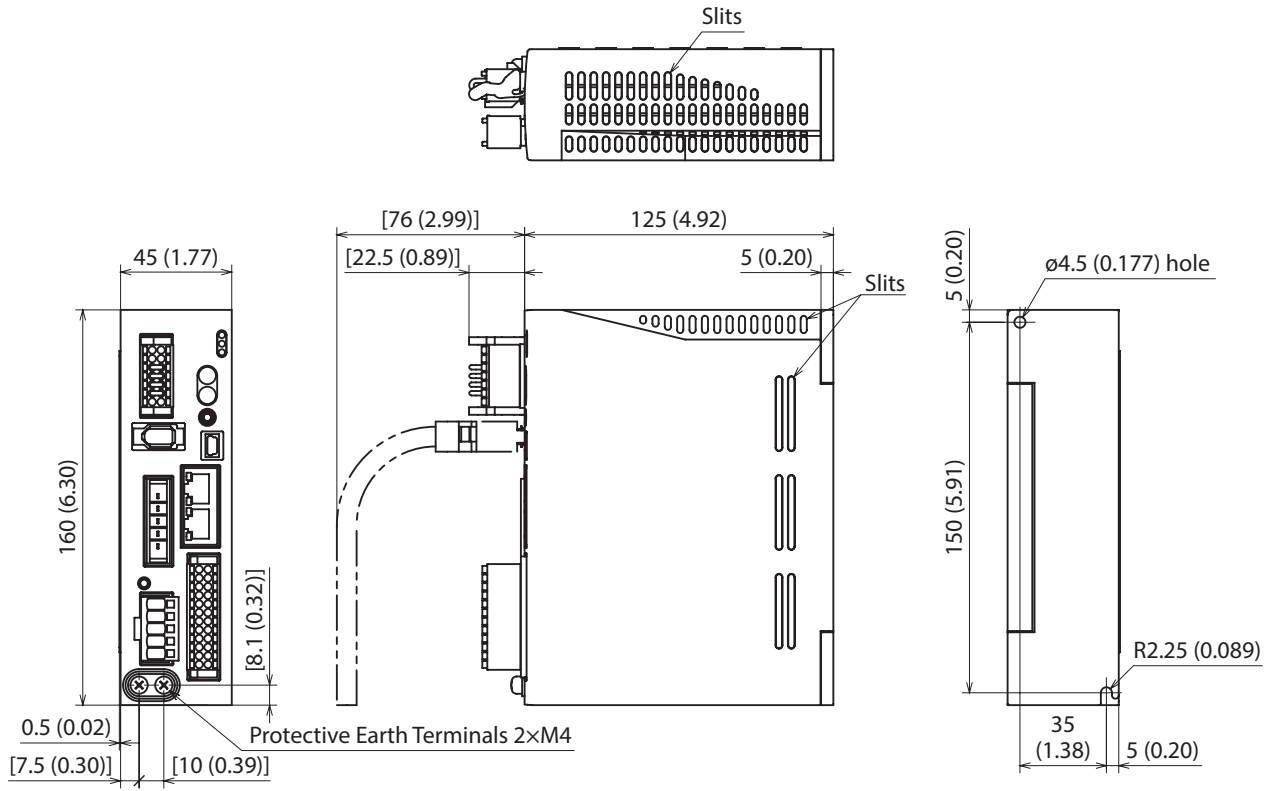

2 AC power input type

4 Connection

This chapter explains a connection example of a driver and a motor, connection methods of power supplies and the regeneration resistor **RGB100**, the grounding method, and others. The installation and wiring methods in compliance with the EMC Directive/Regulations as well as protection against noise are also explained.

⚠️ WARNING

- For protection against electric shock, do not turn on the power supply until the wiring is completed.
- A high voltage is applied to the motor connector (CN3) and the main power supply input terminals (CN4). Do not touch them while the power is on. Doing so may result in fire or electric shock.

4-1 Connection example

Use connection cables of Oriental Motor to connect the motor. Check the cable models on p.51. The figure shows an example when the cable type electromagnetic brake motor with single-phase 200-240 VAC input is used.

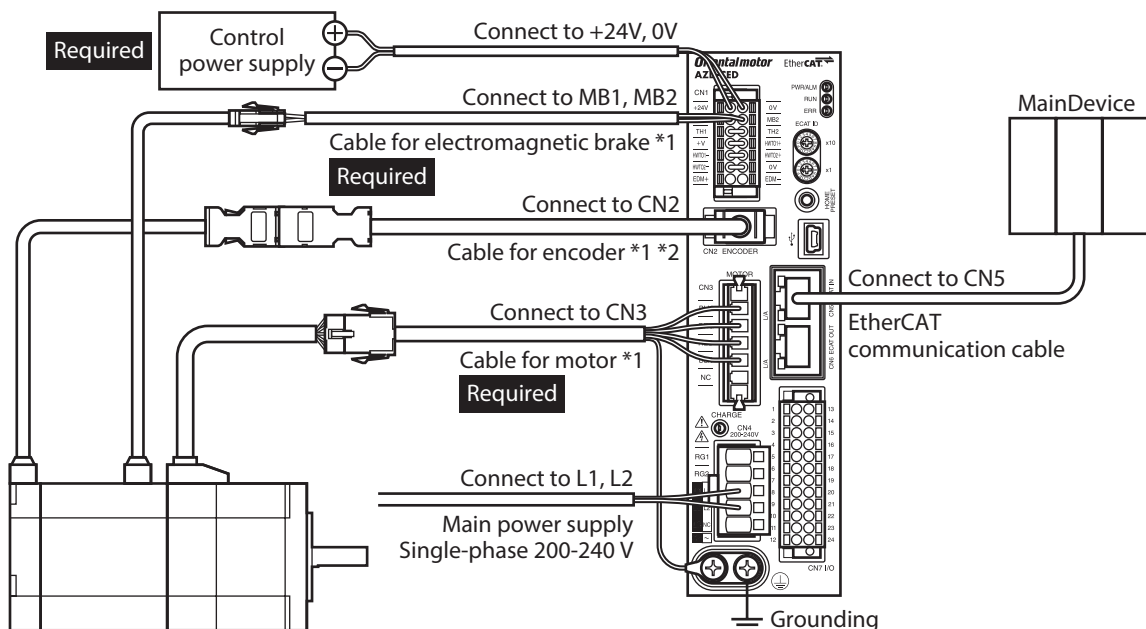

*1 These cables are provided as our products. Purchase it separately.
 *2 Use the cable for encoder when the length of the encoder cable of motor is not enough.

Note

- Connect the connectors securely. Insecure connections may cause malfunction or damage to the motor or the driver.
- Before connecting or disconnecting a connector, turn off the main power supply and the control power supply, and check the CHARGE LED has been turned off. The residual voltage may cause electric shock.
- The lead wires of the "cable for electromagnetic brake" have polarities, so connect them in the correct polarities. If the lead wires are connected with their polarities reversed, the electromagnetic brake will not operate properly.
- Do not wire the power supply cable of the driver in the same cable duct with other power lines or motor cable. Doing so may cause malfunction due to noise.
- Keep the wiring distance between the motor and the driver equal to or less than the following values. Exceeding the following wiring distance may cause the driver to generate heat or increase the electrical noise emitted from the product.
 Cable type: 20 m (65.6 ft.)
 Connector type: 10 m (32.8 ft.)

2 AC power input type



- A control power supply is required with or without an electromagnetic brake. Be sure to connect it.
- When pulling off the motor cable, do so while pressing the latches on the connector with fingers.
- When installing the motor on a moving part, use a flexible cable. Refer to p.51 for the model name.

■ **Electrical wire size**

Connector	Terminal symbol	Recommended wire size
CN1	+24V, 0V, MB1, MB2, TH1, TH2, HWTO1+, HWTO1-, HWTO2+, HWTO2-, EDM+, EDM-	Stranded wire or solid wire AWG24 to 16 (0.2 to 1.25 mm ²)
CN4	RG1, RG2, L, N, L1, L2, L3	Stranded wire or solid wire AWG18 to 14 (0.75 to 2.0 mm ²)
CN7	-	Stranded wire or solid wire AWG24 to 16 (0.2 to 1.25 mm ²)

4-2 Connecting the control power supply

■ **Pin assignment**

There are two terminals for 0V: One for control power supply and the other is for internal connection. Check each position in the figure and the table shown.

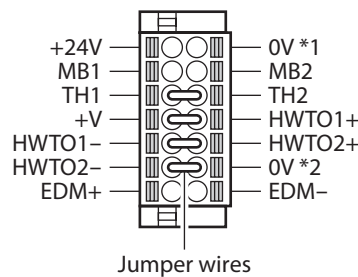

2 AC power input type

Sign	Description
+24V, 0V *1	Connects the control power supply.
MB1, MB2	Connects the lead wires from the electromagnetic brake. MB1: Electromagnetic brake- (Black) MB2: Electromagnetic brake+ (White)
TH1, TH2	Connects the signal lines of our regeneration resistor RGB100 . If the regeneration resistor is not used, connect a jumper wire between the terminals to short-circuit as shown in the figure.
HWTO1+, HWTO1- HWTO2+, HWTO2-	Connects the external device. When using the power removal function, remove the jumper wires and connect the external device. If the power removal function is not used, connect jumper wires between the terminals to short-circuit as shown in the figure.
EDM+, EDM-	Connects the external device. If the power removal function is not used, do not connect anything.
+V, 0V *2	These are for internal connection. Do not connect anything. If the power removal function is not used, connect a jumper wire between the terminals to short-circuit as shown in the figure.

■ **Wiring method of CN1 connector**

- Applicable lead wire: AWG24 to 16 (0.2 to 1.25 mm²)
 - Stripping length of wire insulation: 10 mm (0.39 in.)
1. Strip the insulation of the lead wire.
 2. Insert the lead wire while pushing the button of the orange color with a slotted screwdriver.
 3. After having inserted, release the button to secure the lead wire.

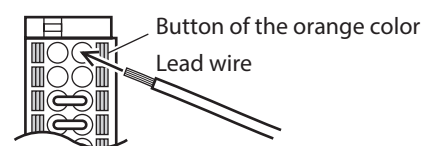

■ Power supply current capacity

Input power supply voltage	Power supply current capacity	
	Without electromagnetic brake	With electromagnetic brake
24 VDC±5 % *1	0.25 A	0.5 A *2

*1 When an electromagnetic brake motor is used, if the wiring distance between the cable type motor and the driver is extended to 20 m (65.6 ft.) using our cable, the input voltage is 24 VDC±4 %.

*2 The **AZM46** type is 0.33 A.

4-3 Connecting the regeneration resistor

If vertical drive (gravitational operation) such as elevating applications is performed or if sudden start-stop operation of a large inertia is repeated frequently, connect our regeneration resistor **RGB100**.

- The two thin lead wires (AWG22: 0.3 mm²) of the regeneration resistor are the thermostat outputs. Connect them to the TH1 and TH2 using the CN1 connector.
- Regenerative current flows through the two thick lead wires (AWG18: 0.75 mm²) of the regeneration resistor. Connect them to the RG1 and RG2 using the CN4 connector.

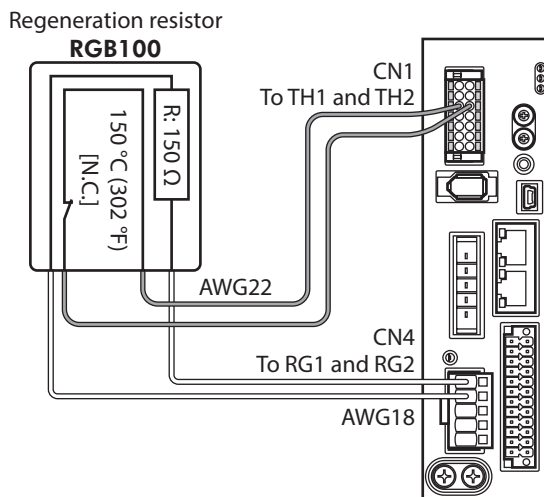

2 AC power input type

Note A sticker is placed on RG1 and RG2 of the CN4 connector to prevent incorrect wiring. Remove the sticker only when connecting the regeneration resistor. Incorrectly connecting the lead wires of the main power supply may result in damage to the product.

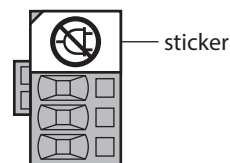

- memo**
- When connecting the regeneration resistor, be sure to remove the jumper wire from the CN1 connector.
 - If the allowable power consumption of the regeneration resistor exceeds the allowable level, the thermostat will be triggered to generate an alarm of regeneration resistor overheat. When an alarm of regeneration resistor overheat is generated, turn off the main power supply and check the error content.

● Regeneration resistor specifications

Model	RGB100
Allowable power consumption	Continuous regenerative power: 50 W * Instantaneous regenerative power: 600 W
Resistance value	150 Ω
Thermostat operating temperature	Operation: Opens at 150±7 °C (302±12.6 °F) Reset: Closes at 145±12 °C (293±21.6 °F) [normally closed]
Thermostat electrical rating	120 VAC 4 A or 30 VDC 4A (minimum current 5 mA)

* Install the regeneration resistor in a location where heat dissipation capacity equivalent to a level achieved with a aluminum plate [350×350×3 mm (13.78×13.78×0.12 in.)] is ensured.

4-4 Connecting the main power supply

The connecting method varies depending on the power supply specification.

Note Do not connect the lead wires of the main power supply to the regeneration resistor connection terminals (RG1, RG2). Doing so may result in damage to the product.

Single-phase 100-120 V –15 % to +6 %
50/60 Hz

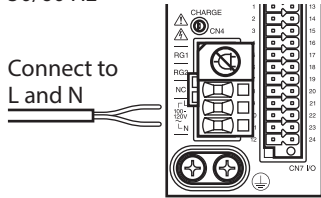

Single-phase 200-240 V –15 % to +6 %
50/60 Hz

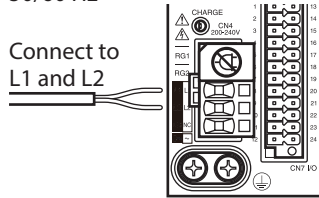

Three-phase 200-240 V –15 % to +6 %
50/60 Hz

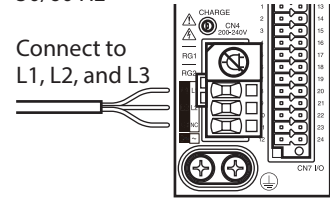

■ Wiring method of CN4 connector

- Applicable lead wire: AWG18 to 14 (0.75 to 2.0 mm²)
- Stripping length of wire insulation: 9 mm (0.35 in.)

1. Strip the insulation of the lead wire.
2. Insert the connector lever.
3. Insert the lead wire while pushing down the connector lever.

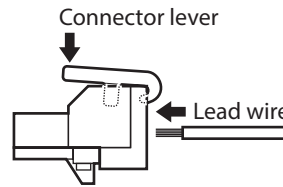

■ Power supply current capacity

The current capacity of the power supply varies depending on the product combined.

Check the current capacity in reference to the equipped motor model when using the **EAS** Series, **EAC** Series, **EZS** Series, or **EZSH** Series.

The box (□) in the model indicates an alphabet (**B**, **M**, or **R**) representing the shape of the actuator.

- **Single-phase 100-120 VAC**
- **Single-phase 200-240 VAC**
- **Three-phase 200-240 VAC**

Model	Power supply current capacity
AZM46	2.7 A or more
AZM48	2.7 A or more
AZM66	3.8 A or more
AZM69	5.4 A or more
AZM98	5.5 A or more
AZM911	6.4 A or more
DG□85	2.7 A or more
DG□130	3.8 A or more
DG□200	6.4 A or more
LM2	3.8 A or more
LM4	3.8 A or more

Model	Power supply current capacity
AZM46	1.7 A or more
AZM48	1.6 A or more
AZM66	2.3 A or more
AZM69	3.3 A or more
AZM98	3.3 A or more
AZM911	3.9 A or more
DG□85	1.7 A or more
DG□130	2.3 A or more
DG□200	3.9 A or more
LM2	2.3 A or more
LM4	2.3 A or more

Model	Power supply current capacity
AZM46	1.0 A or more
AZM48	1.0 A or more
AZM66	1.4 A or more
AZM69	2.0 A or more
AZM98	2.0 A or more
AZM911	2.3 A or more
DG□85	1.0 A or more
DG□130	1.4 A or more
DG□200	2.3 A or more
LM2	1.4 A or more
LM4	1.4 A or more

4-5 Grounding the driver

Two Protective Earth Terminals (screw size: M4) are provided on the driver. Be sure to ground one of the Protective Earth Terminals. Either of the two Protective Earth Terminals can be used for grounding the driver.

- Grounding wire: AWG16 to 14 (1.25 to 2.0 mm²)
- Tightening torque: 1.2 N·m (170 oz·in)

Connect the grounding wire of the "cable for motor" to the other terminal to ground the motor.

Do not share the grounding wire with a welder or any other power equipment.

When grounding the Protective Earth Terminal, use a round terminal and secure the grounding point near the driver.

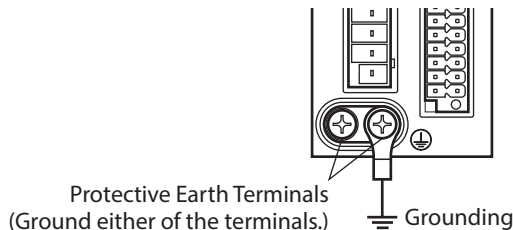

4-6 Connecting the EtherCAT communication cable

Connect the MainDevice and the CN5 connector (ECAT IN) on the driver using the EtherCAT communication cable. Be sure to connect from the CN6 connector (ECAT OUT) to the CN5 connector (ECAT IN) when linking drivers.

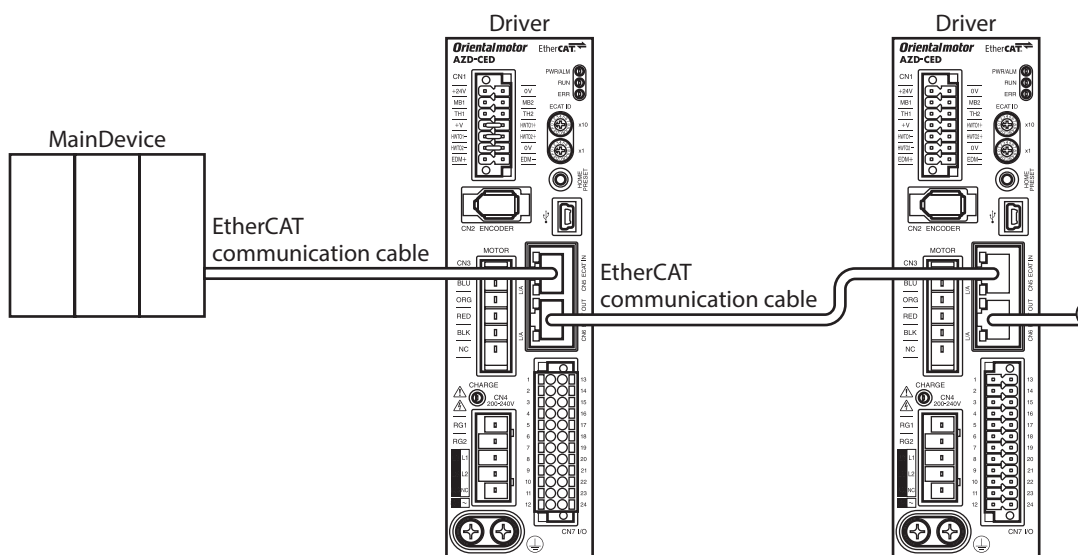

2 AC power input type

■ Pin assignment

Signal name	Description
TXP	Transmitted data+
TXN	Transmitted data-
RXP	Received data+
N.C.	—
N.C.	—
RXN	Received data-
N.C.	—
N.C.	—

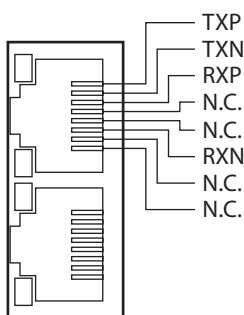

4-7 Connecting the USB cable

Using a USB cable of the following specification, connect a PC in which the **MEXE02** has been installed to the USB communication connector.

Specification	USB2.0 (full speed)
Cable	Length: 3 m (9.8 ft.) or less Shape: A to mini B



- Connect the driver and PC directly using the USB cable.
- In large electrically noisy environments, use the USB cable with a ferrite core or install a ferrite core to the USB cable.

4-8 Connecting the I/O signals

Connect when using direct I/O or sensors.

■ Pin assignment

Pin No.	Signal name *	Description *
1	CW+ [PLS+]	CW pulse input+ [Pulse input+]
2	CCW+ [DIR+]	CCW pulse input+ [Rotation direction switching input+]
3	IN0	Control input 0 (HOMES)
4	IN2	Control input 2 (ETO-CLR)
5	IN-COM 0-3	IN0 to IN3 inputs common
6	IN4	Control input 4 (FW-LS)
7	OUT0	Control output 0 (HOME-END)
8	OUT2	Control output 2 (PLS-RDY)
9	OUT4	Control output 4 (MOVE)
10	OUT-COM	Output common
11	ASG+	Phase A pulse output+
12	BSG+	Phase B pulse output+

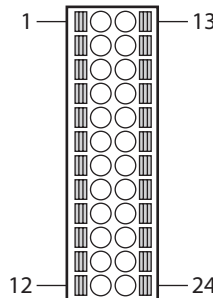

Pin No.	Signal name *	Description *
13	CW- [PLS-]	CW pulse input- [Pulse input-]
14	CCW- [DIR-]	CCW pulse input- [Rotation direction switching input-]
15	IN1	Control input 1 (FREE)
16	IN3	Control input 3 (EXT1)
17	IN-COM 4-5	IN4, IN5 inputs common
18	IN5	Control input 5 (RV-LS)
19	OUT1	Control output 1 (ETO-MON)
20	OUT3	Control output 3 (CRNT)
21	OUT5	Control output 5 (ALM-B)
22	GND	GND
23	ASG-	Phase A pulse output-
24	BSG-	Phase B pulse output-

* Values in brackets [] are signals when the 1-pulse input mode is set.
Values in parentheses () are initial values.

■ Wiring method of CN7 connector

- Applicable lead wire: AWG24 to 16 (0.2 to 1.25 mm²)
- Stripping length of wire insulation: 10 mm (0.39 in.)

1. Strip the insulation of the lead wire.
2. Insert the lead wire while pushing the button of the orange color with a slotted screwdriver.
3. After having inserted, release the button to secure the lead wire.

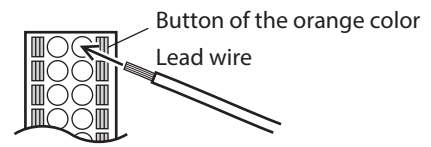

Be certain the I/O signal cable is as short as possible. The maximum input frequency will decrease as the cable length increases.

■ Connection example with a current sink output circuit

● When the pulse input circuit of the driver is of line driver type

The pin No.1, No.2, No.13, and No.14 are only available to the pulse input. Other functions cannot be assigned.

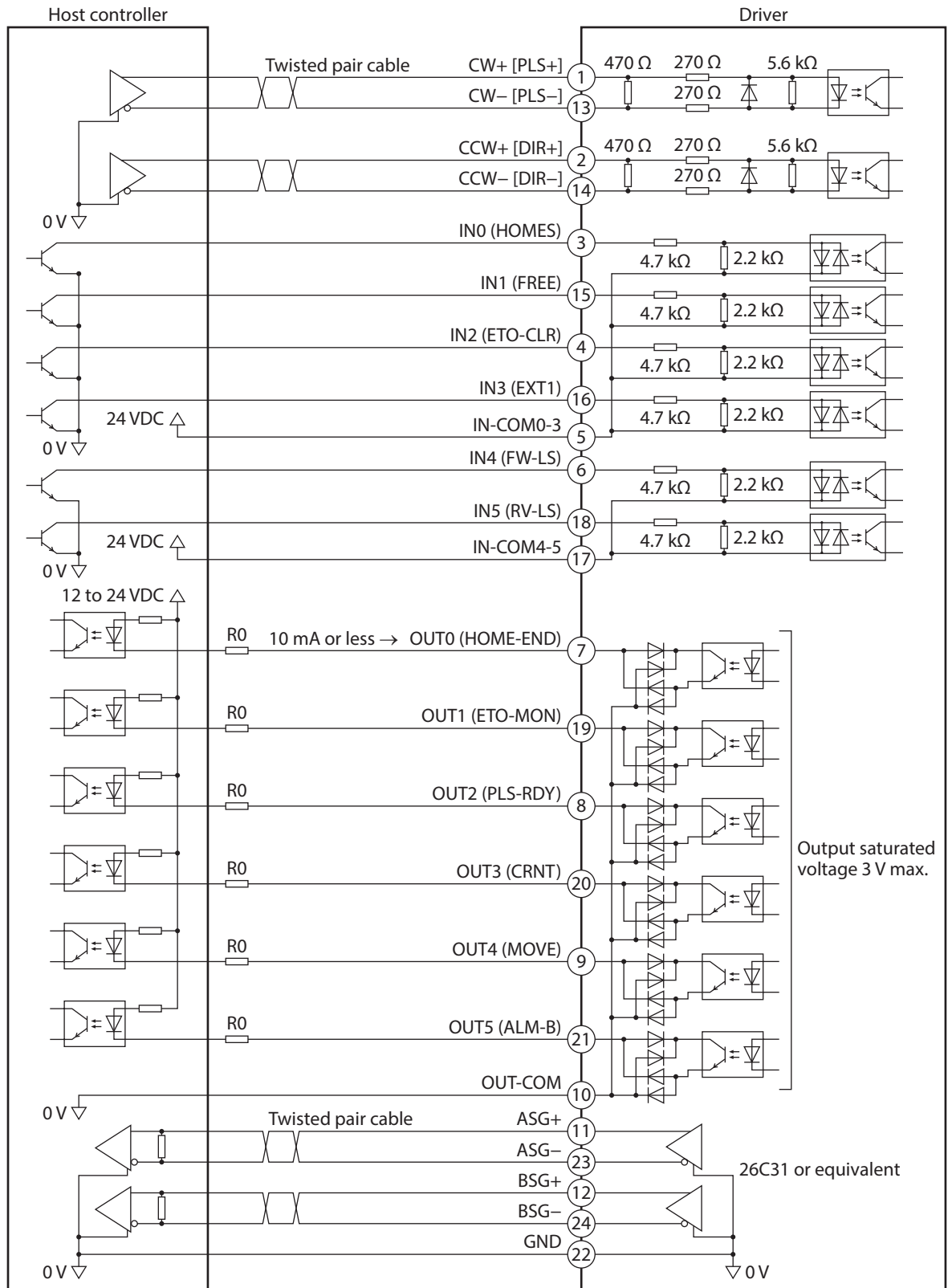

* Values in brackets [] are signals when the 1-pulse input mode is set.
 Values in parentheses () are initial values.



- Use input signals at 24 VDC.
- Use output signals at 12 to 24 VDC, 10 mA or less. If the current exceeds 10 mA, connect an external resistor R0 so that the current becomes 10 mA or less.
- The saturated voltage of the output signal is 3 V maximum.

● **When the pulse input circuit of the driver is of open collector type**

The pin No.1, No.2, No.13, and No.14 are only available to the pulse input. Other functions cannot be assigned.



Use the CW [PLS] input and CCW [DIR] input at 5 to 24 VDC. When using signals at 24 VDC, connect an external resistor R1 (1.2 kΩ to 2.2 kΩ, 0.5 W or more). When using signals at 5 VDC, apply the voltage directly.

When the voltage of pulse input signals is 5 VDC

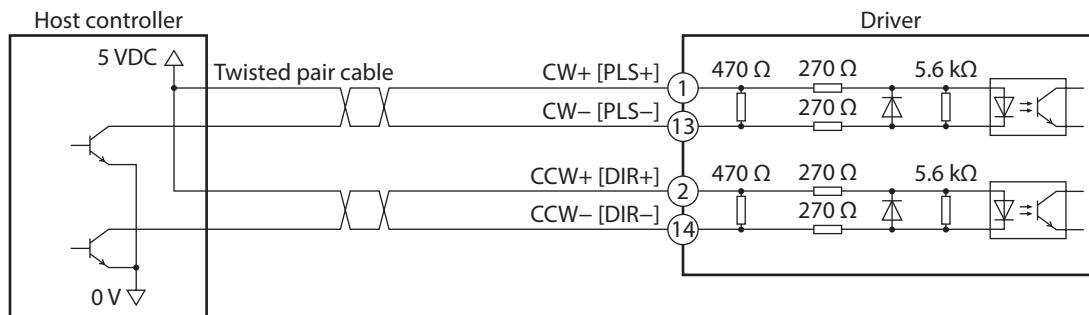

* Values in brackets [] are signals when the 1-pulse input mode is set.

When the voltage of pulse input signals is 24 VDC

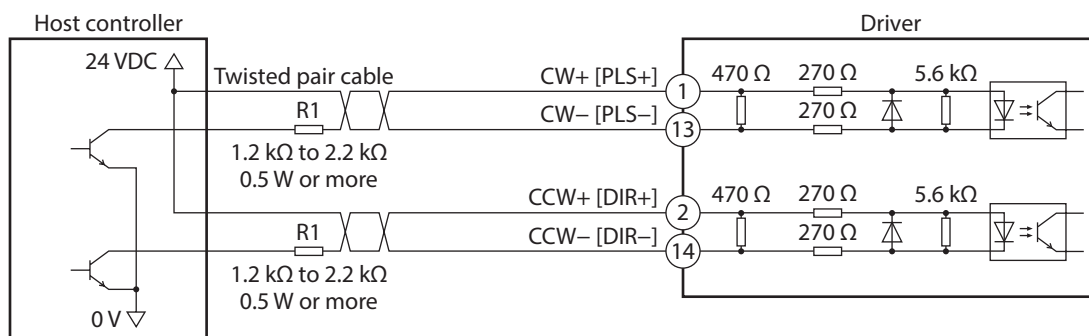

* Values in brackets [] are signals when the 1-pulse input mode is set.

■ Connection example with a current source output circuit

● When the pulse input circuit of the driver is of line driver type

The pin No.1, No.2, No.13, and No.14 are only available to the pulse input. Other functions cannot be assigned.

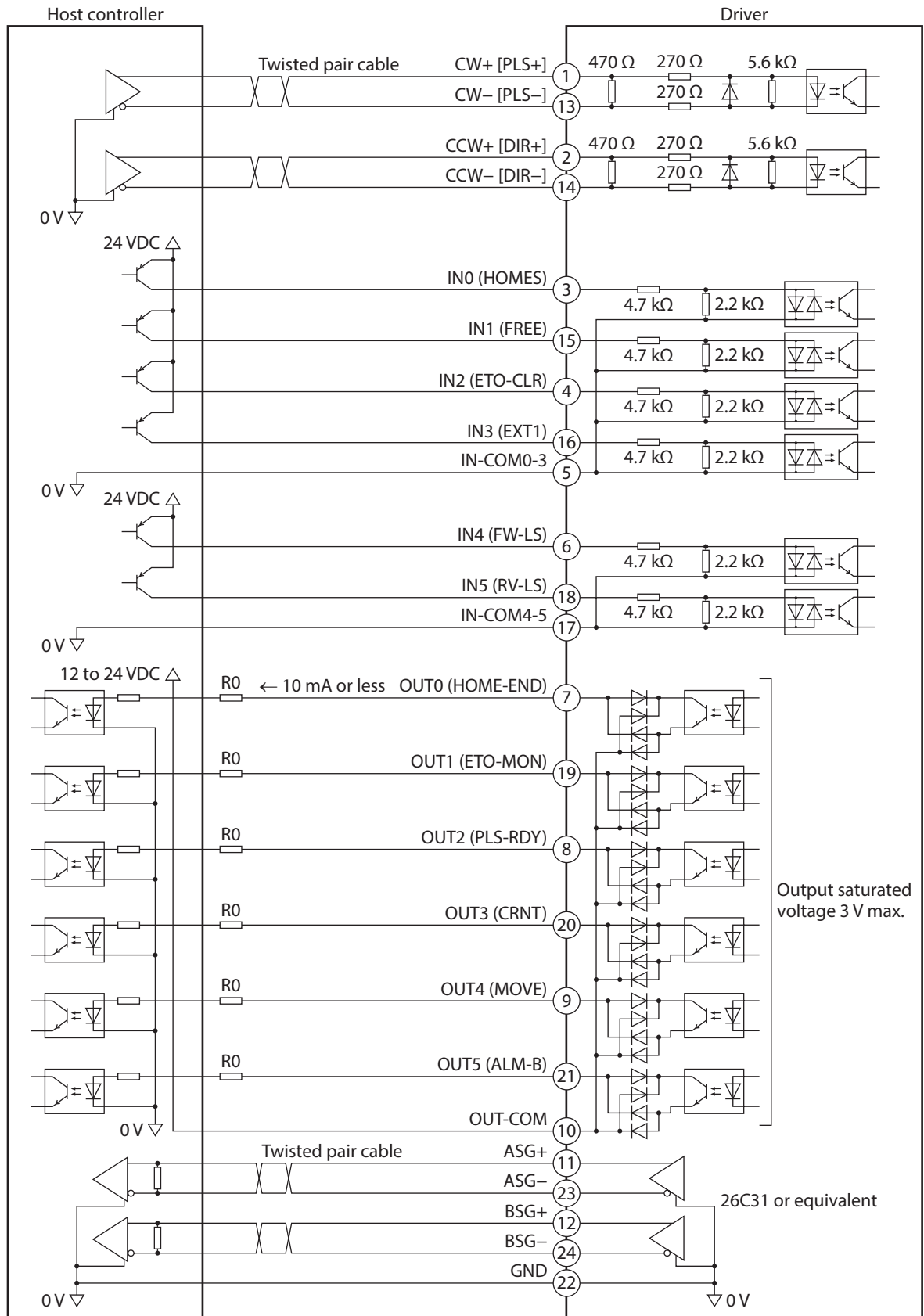

* Values in brackets [] are signals when the 1-pulse input mode is set.
Values in parentheses () are initial values.



- Use input signals at 24 VDC.
- Use output signals at 12 to 24 VDC, 10 mA or less. If the current exceeds 10 mA, connect an external resistor R0 so that the current becomes 10 mA or less.
- The saturated voltage of the output signal is 3 V maximum.

● **When the pulse input circuit of the driver is of open collector type**

The pin No.1, No.2, No.13, and No.14 are only available to the pulse input. Other functions cannot be assigned.



Use the CW [PLS] input and CCW [DIR] input at 5 to 24 VDC. When using signals at 24 VDC, connect an external resistor R1 (1.2 kΩ to 2.2 kΩ, 0.5 W or more). When using signals at 5 VDC, apply the voltage directly.

When the voltage of pulse input signals is 5 VDC

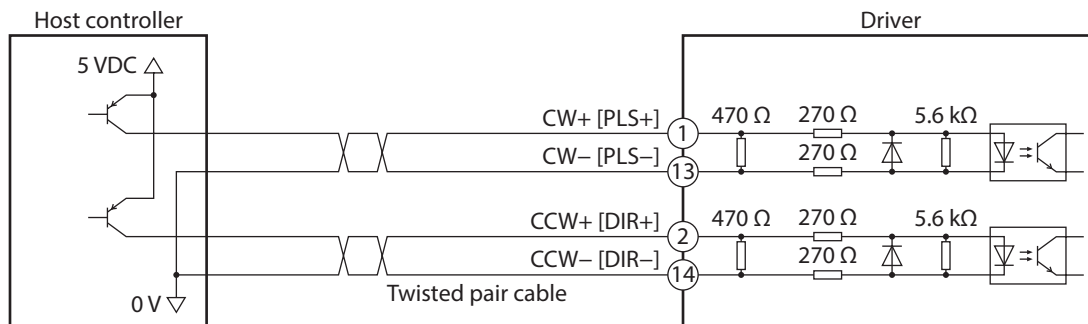

* Values in brackets [] are signals when the 1-pulse input mode is set.

When the voltage of pulse input signals is 24 VDC

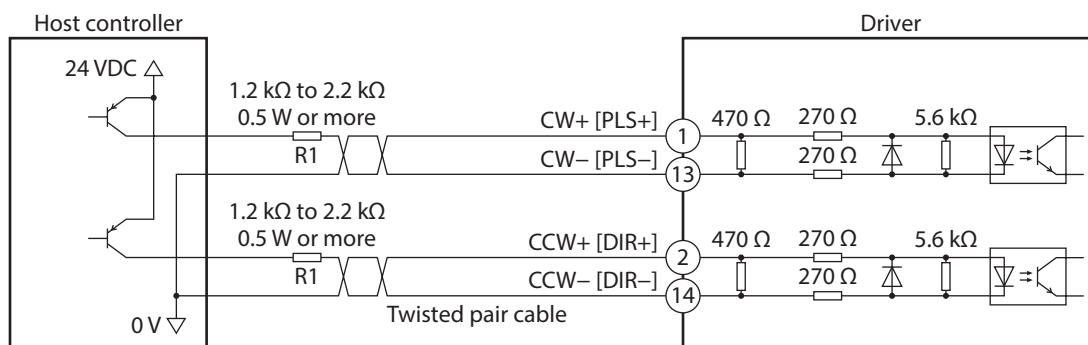

* Values in brackets [] are signals when the 1-pulse input mode is set.

4-9 Noise elimination measures

There are two types of electrical noises: One is a noise to invade into the driver from the outside and cause the driver malfunction, and the other is a noise to emit from the driver and cause peripheral equipment malfunction. For the noise that is invaded from the outside, take measures to prevent the driver malfunction. It is needed to take adequate measures because signal lines are very likely to be affected by the noise. For the noise that is emitted from the driver, take measures to suppress it.

■ Measures against electrical noise

There are the following three methods mainly to take measures against the electrical noise.

● Noise suppression

- When relays or electromagnetic switches are used, use noise filters or CR circuits to suppress surge generated by them.
- Use our connection cable when extending the wiring distance between the motor and the driver. Refer to p.51 for the model name. This is effective in suppressing the electrical noise emitted from the motor.
- Cover the driver by a metal plate such as aluminum. This is effective in shielding the electrical noise emitted from the driver.

● Prevention of noise propagation

- Connect a noise filter to the power supply cable of the driver.
- Place the power lines, such as the motor and the power supply cables, keeping a distance of 200 mm (7.87 in.) or more from the signal lines, and also do not bundle them or wire them in parallel. If a power cable and a signal cable have to cross, cross them at a right angle.
- Use shielded twisted pair cables for power lines and signal lines.
- Keep cables as short as possible without coiling and bundling extra lengths.
- Grounding multiple points will increase effect to block electrical noise because impedance on the grounding points is decreased. However, ground them so that a potential difference does not occur among the grounding points. I/O signal cable that includes a ground wire are provided in our product line. Refer to p.55 for the model name.
- To ground a shielded cable, use a metal cable clamp that can maintain contact with the entire circumference of the shielded cable, and ground as near the product as possible.

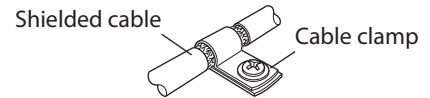

● Suppression of effect by noise propagation

- Loop the noise propagated cable around a ferrite core. Doing so will prevent the propagated noise invades into the driver or emits from the driver. The frequency band in which an effect by the ferrite core can be seen is generally 1 MHz or more. Check the frequency characteristics of the ferrite core used. When increasing the effect of noise attenuation by the ferrite core, loop the cable a lot.
- Change the transmission method of the pulse signal to the line driver type in order to prevent noise effects. If the pulse signal of the host controller is of the open collector type, use our pulse signal converter for noise immunity. Refer to p.56 for the model name.

■ Noise suppression product

● Noise filter

- Connect the following noise filter (or equivalent) to the power line. Doing so will prevent the propagated noise through the power line. Install the noise filter as close to the driver as possible.

Manufacturer	Single-phase 100-120 VAC Single-phase 200-240 VAC	Three-phase 200-240 VAC
SOSHIN ELECTRIC CO., LTD.	HF2010A-UPF	HF3010C-SZA
Schaffner EMC	FN2070-10-06	FN3025HP-10-71

- Use the AWG18 (0.75 mm²) or thicker wire for the input and output cables of the noise filter, and secure firmly using a cable clamp or others so that the cable does not come off the enclosure.
- Place the input cable as far apart as possible from the output cable, and do not wire the cables in parallel. If the input and output cables are placed at a close distance or if they are wired in parallel, the noise in the enclosure affects the power cable through stray capacitance, and the noise suppressing effect will reduce.
- Connect the ground terminal of the noise filter to the grounding point, using as thick and short a wire as possible.
- When connecting a noise filter inside an enclosure, wire the input cable of the noise filter as short as possible. Wiring in long distance may reduce the noise suppressing effect.

■ Our noise suppression products

Check the model names on p.55 and p.56.

● I/O signal cable

This is a shielded cable for good noise immunity to connect the driver and the host controller. The ground wire useful to grounding is extracted from both ends of the cable. The EMC testing is conducted using our I/O signal cable.

● Pulse signal converter for noise immunity

This product converts a pulse signal, which is output from the open collector output, to a pulse signal for good noise immunity by outputting the pulse signal again from the differential output.

● Surge suppressor

This product is effective to suppress the surge which occurs in a relay contact part. Connect it when using a relay or electromagnetic switch. CR circuit for surge suppression and CR circuit module are provided.

4-10 Conformity to the EMC Directive/Regulations

Effective measures must be taken against the EMI that the motor and the driver may give to adjacent control-system equipment, as well as the EMS of the motor and the driver itself, in order to prevent a serious functional impediment in the machinery. The use of the following installation and wiring methods will enable the motor and the driver to be compliant with the EMC Directive/Regulations.

Oriental Motor conducts EMC testing on its motors and drivers in accordance with "Example of installation and wiring" on p.38.

The user is responsible for ensuring the machine's compliance with the EMC, based on the installation and wiring explained next.

CAUTION

This equipment is not intended for use in residential environments nor for use on a low-voltage public network supplied in residential premises, and it may not provide adequate protection to radio reception interference in such environments.

● Connecting the noise filter

In large electrically noisy environments, connect a noise filter. Refer to "Noise filter" on p.36 for details.

● Connecting the control power supply

Use a DC power supply compliant with the EMC Directive/Regulations for the control power supply. Wire and ground the power supply over the shortest possible distance using a shielded cable. Refer to "Prevention of noise propagation" on p.36 for how to ground the shielded cable.

● Connecting the motor cable

Use our connection cable when extending the wiring distance between the motor and the driver. Refer to p.51 for the model name.

● Connecting the signal cable

Refer to "Prevention of noise propagation" on p.36.

● Grounding method

- The cable used to ground the motor, the driver, and the noise filter must be as thick and short as possible so that no potential difference is generated.
- Choose a large, thick and uniformly conductive surface for the grounding point.
- When installing the motor and the driver, ground their Protective Earth Terminals. Refer to the p.29 for how to ground the driver.

● **Example of installation and wiring**

Use connection cables of Oriental Motor to connect the motor. Check the cable models on p.51. The figure shows an example when the cable type electromagnetic brake motor is used. The line driver system is used to drive the pulse signals.

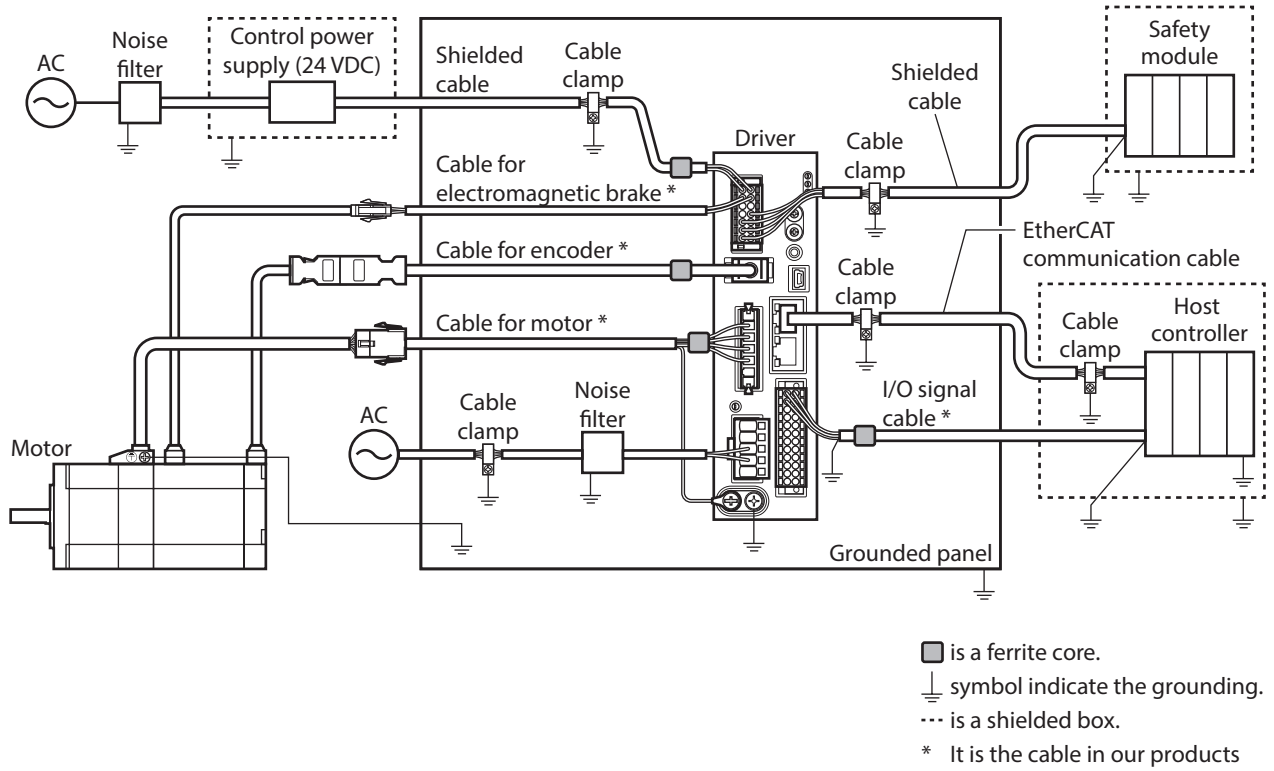

Note

The driver uses parts that are sensitive to electrostatic charge. Take measures against static electricity since static electricity may cause the driver to malfunction or suffer damage.

5 Setting of node address

This chapter explains how to set the node address.

5-1 Setting method

Set the node address using two node address setting switches (ECAT ID ×10, ×1).

The node address setting switches are hexadecimal number. Convert the node address from decimal to hexadecimal to set.

When connecting two or more EtherCAT communication compatible products, do not set duplicate node address.

Factory setting: 0 (×10: 0, ×1: 0)

Setting range	Description
0 (00h)	The setting of the MainDevice is enabled.
1 to 255 (1h to FFh)	The setting of the driver is enabled.



Be sure to turn off the control power supply of the driver before setting the switches. If the switches are set while the control power supply is in an on-state, the new setting will not be enabled.

6 Power removal function

The power removal function is a function that stops supplying the power to the motor by the hardware. This function shuts off the drive signal of the inverter circuit that controls the motor current with two input channels (HWTO1 input, HWTO 2 input). This brings a shutoff state of the power supplying to the motor (power removal status). The power removal function is assumed to be used to prevent unexpected starting of the moving parts of equipment when an operator works inside the operating range of the moving parts.

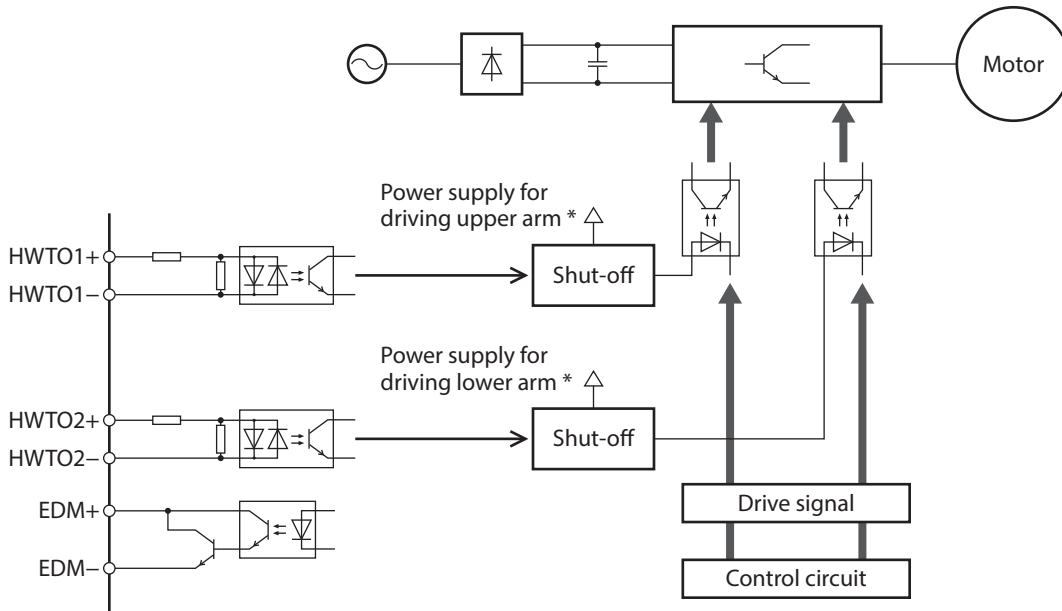

* Turning the HWTO1 input OFF causes the upper arm drive signal of the inverter circuit to shut off. Turning the HWTO2 input OFF causes the lower arm drive signal of the inverter circuit to shut off.

Note Be sure to check the motor is in a standstill state before executing the power removal function. If the power removal function is executed while the motor is operated, it may cause damage to the motor, driver, or equipment.

6-1 Safety parameters

Item	Specifications
Safety integrity level	SIL 3 *
Average frequency of a dangerous failure per hour	PFH=2.96×10 ⁻⁹ [1/h]
Hardware fault tolerance	HFT=1
Subsystem	Type A
Mission time	10 years
Response time	15 ms or less
Performance level	PL e (Category 3) *
Mean time to dangerous failure	MTTFd: High
Average diagnostic coverage	DC _{avg} : Medium
Stop category	0 (IEC 60204-1)

* It is necessary to monitor the EDM output using an external device.

6-2 Notes when using the power removal function

- When the power removal function is used, be sure to conduct a risk assessment of equipment in advance and check that the safety requirements of the safety-related parts of a control system are satisfied.
- The design of the safety-related parts of a control system using the power removal function should be performed by qualified personnel who are trained in the relevant safety standards and understand the contents of this chapter.
- If the power removal function operates, the motor output shaft may rotate due to external forces (such as gravity on a vertical axis). To hold the motor output shaft in position, install an external brake mechanism or equivalent. The brake mechanism of the electromagnetic brake motor is used for the purpose to hold the position. Do not use the brake mechanism of the electromagnetic brake motor for braking the motor rotation. This may result in injury or damage to equipment.
- If the power removal function operates, the driver stops supplying the power to the motor. However, the power supplying to the driver is not shut off, and the driver is not performed electrical insulation either. Before performing maintenance or inspection, always turn off the driver power, and check the CHARGE LED is turned off. Failure to do so may result in electric shock.
- If the inverter circuit is failed, the motor output shaft may rotate up to 180 degrees in an electrical angle (3.6 degrees in a mechanical angle) even when the power removal function operates. Make sure this movement does not cause hazardous situations. Failure to do so may result in injury or damage to equipment.
- Connect the I/O signals related to the power removal function to an external device that is certified under safety standards.
- Be sure to perform the verification testing of the power removal function when starting up or maintaining the equipment, or when replacing the driver. This may result in injury or damage to equipment. If the power removal function is used in an incorrect state such as incorrect wiring of I/O signals, the power removal function may not operate properly, causing hazardous situations.

6-3 I/O signals

■ HWTO1 input, HWTO2 input

The HWTO1 input and HWTO2 input are signals to operate the power removal function. Connect 24 VDC to the HWTO1+ and HWTO2+ terminals and 0 VDC to the HWTO1- and HWTO2- terminals.

Note Provide individual contacts for operating the HWTO1 input and the HWTO2 input.

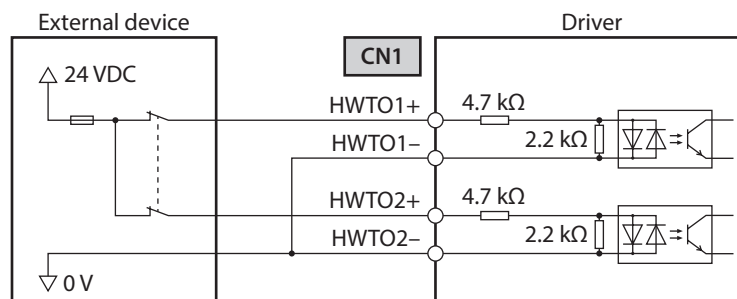

Specification

- Input voltage: 24 VDC \pm 10 %

Safety input-off shot pulse for self-diagnosis of external device

If the safety output signal output from an external device includes the safety input-off shot pulse for self-diagnosis, use an external device which pulse width is 1 ms or less. If the OFF-time of the HWTO1 input or the HWTO2 input by the safety input-off shot pulse is 1 ms or less, the power removal function does not operate.

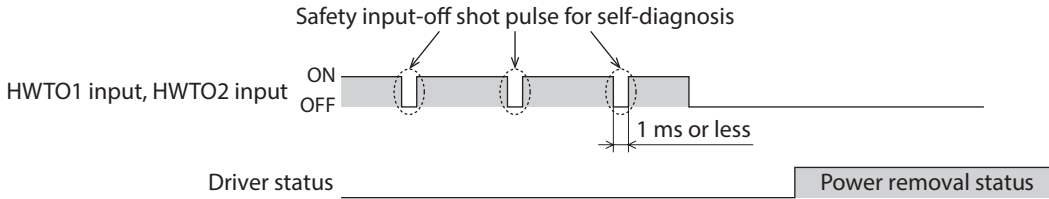

EDM output

The EDM output is a signal to monitor a failure in the power removal function.

Note The EDM output is not an output signal to ensure the safety. Do not use the EDM output for any other purpose except for monitoring a failure.

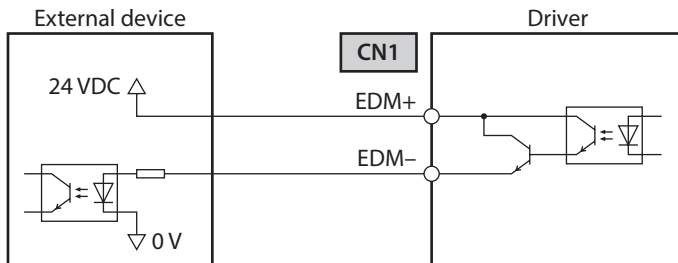

Specifications

- Voltage: 30 VDC or less
- Current: 50 mA or less
- Output saturated voltage: 1.1 V max.

2 AC power input type

6-4 Operation of power removal function

Transition to power removal status

If both the HWTO1 and HWTO2 inputs are turned OFF, the driver transitions to the power removal status, and the power supplying to the motor is shut off by the hardware, causing the motor to put into a non-excitation state. In the power removal status, the status of the motor and driver will be as follows. [When the "HWTO mode selection (4190h)" is set to "0: Alarm is not present (initial value)"]

- The ETO-MON output is ON.
- The DCMD-RDY output, the READY output, the PLS-RDY output, and the MBC output are OFF.
- The PWR/ALM LED blinks in green.
- When an electromagnetic brake motor is used, the electromagnetic brake is in a state of holding the motor output shaft.

Note

- Be sure to check the motor is in a standstill state before executing the power removal function. If the power removal function is executed while the motor is operated, it may cause damage to the motor, driver, or equipment.
- It takes 15 ms maximum from when the HWTO1 and HWTO2 inputs are turned OFF until when the driver is in the power removal status.
- To transition to the power removal status, be sure to turn the HWTO1 and HWTO2 inputs OFF for at least 15 ms.
- The ETO-MON output, the DCMD-RDY output, the READY output, the PLS-RDY output, the MBC output, the PWR/ALM LED, and the electromagnetic brake are not safety-related parts of a control system.

● Timing chart

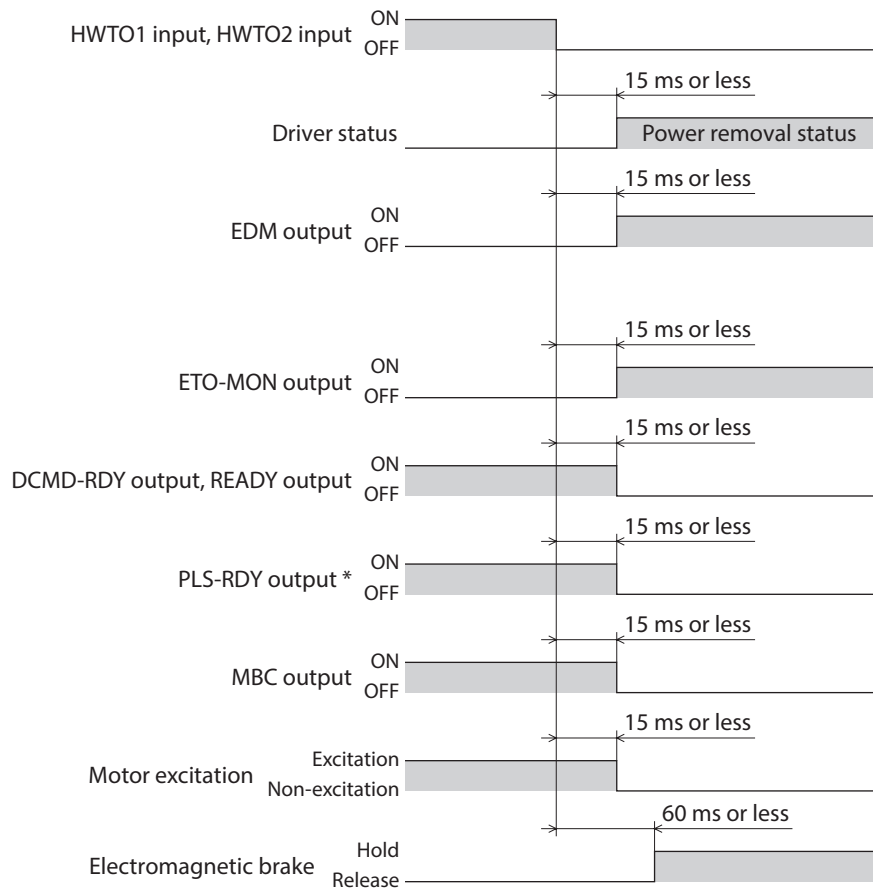

* When executing the operation by inputting pulses.

■ Return from power removal status

If both the HWTO1 and the HWTO2 inputs are turned ON, the power removal status is released. At this time, the motor remains in a non-excitation state. To excite the motor, turn the ETO-CLR input ON in a state where the excitation command is input from the MainDevice. (initial value: Activate at ON edge). When the ETO-CLR input is turned ON, the status of the motor and driver will be as follows.

- The ETO-MON output is OFF.
- The DCMD-RDY output, the READY output, the PLS-RDY output, and the MBC output are ON.
- The PWR/ALM LED is lit in green.
- When an electromagnetic brake motor is used, the electromagnetic brake is in a state of releasing the motor output shaft.

Note

- Check the equipment is in a safe state before returning the driver from the power removal status.
- Even if either the HWTO1 input or the HWTO2 input is turned ON, the power removal status cannot be released.
- If the ON-time of the HWTO1 and HWTO2 inputs is less than 15 ms, the power removal status may not be released.
- When the power removal status is released, a shut-off state of supplying the power to the motor by the hardware is also released.
- The ETO-CLR input is not safety-related part of a control system.

● **Timing chart**

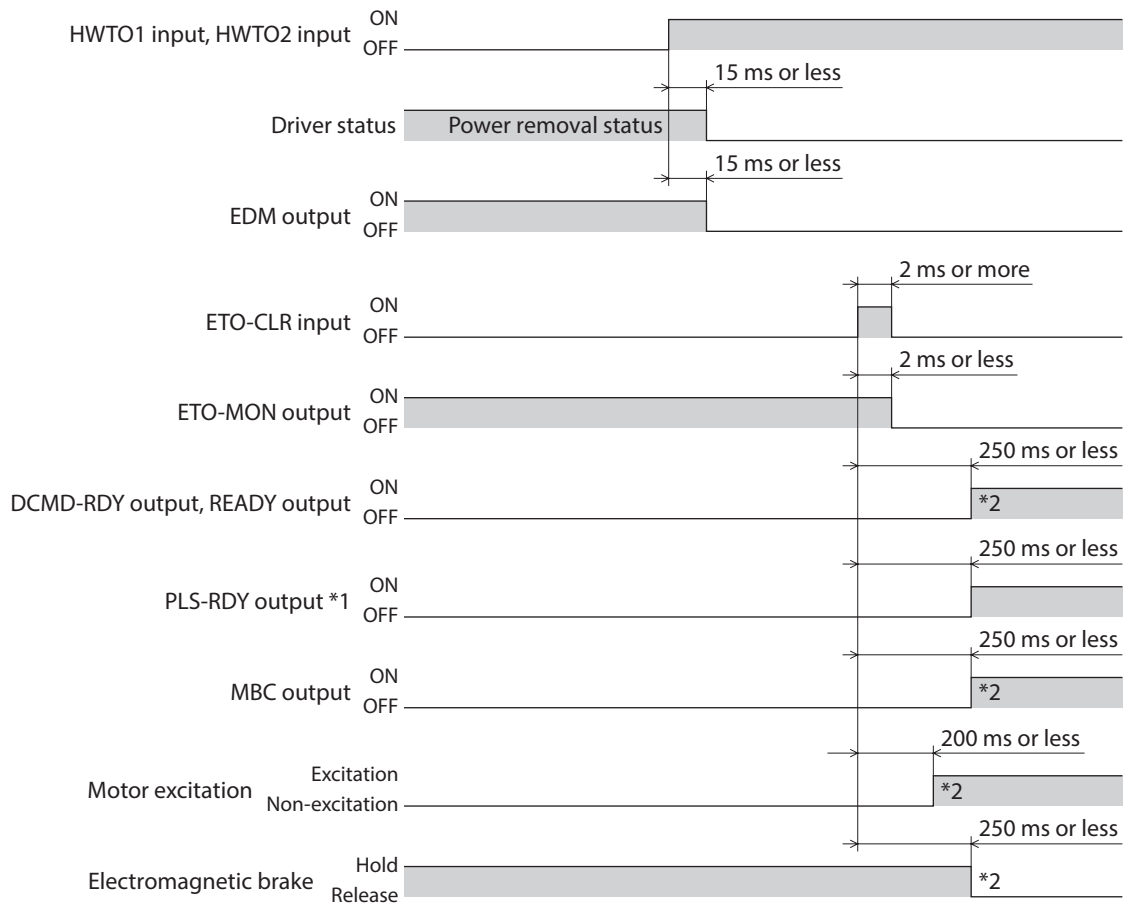

*1 When executing the operation by inputting pulses.

*2 It is the movement when the excitation command is input from the MainDevice while the ETO-CLR input is turned ON.

■ **Detection for failure of the power removal function**

Monitoring the input status of the HWTO1 and HWTO2 inputs and the output status of the EDM output relative to the inputs can detect the failure of the power removal function.

When the power removal function is properly operated, the combination of each signal is any of the following. Combinations other than the table indicate the power removal function of the driver is in a failure state.

HWTO1 input	HWTO2 input	EDM output
ON	ON	OFF
OFF	OFF	ON
ON	OFF	OFF
OFF	ON	OFF

If only one of the HWTO1 input and the HWTO2 input is ON or OFF, the external device or wiring has failed. Check the cause and take a measure immediately. At this time, the EDM output is in an OFF state and the motor puts into a non-excitation state.

- Note**
- Do not release the power removal function when the EDM output is in an OFF state.
 - If the driver or external device is failed or an error in wirings occurs, check the cause and take a measure immediately.
 - The power removal function of the driver is classified in Category 3 of ISO 13849-1. Not all dangerous failures can be detected with the EDM output.

6-5 Example of use

This section describes the connection method that the power removal function operates when the door (guard) is opened using a safety module.

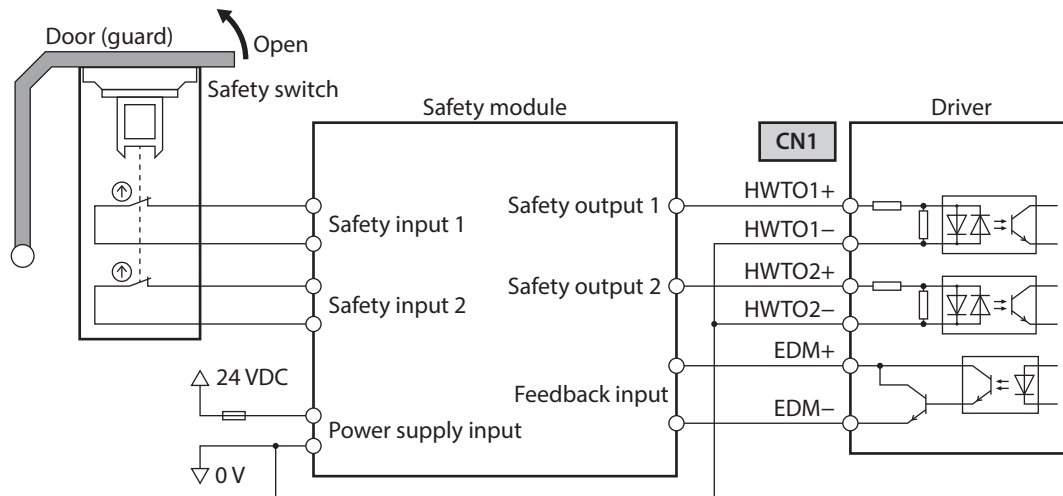

■ Operation in normal state

● When the door (guard) is opened

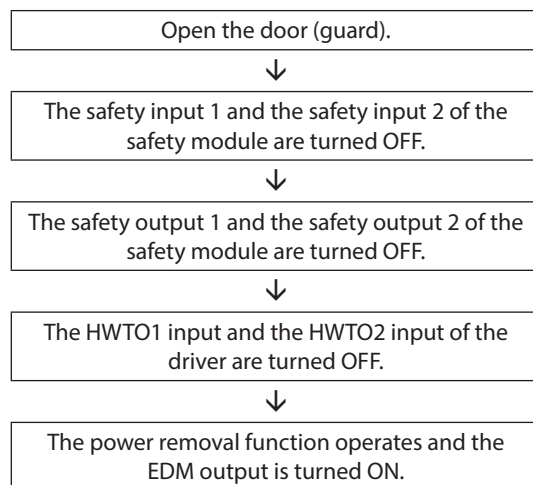

● When the door (guard) is closed

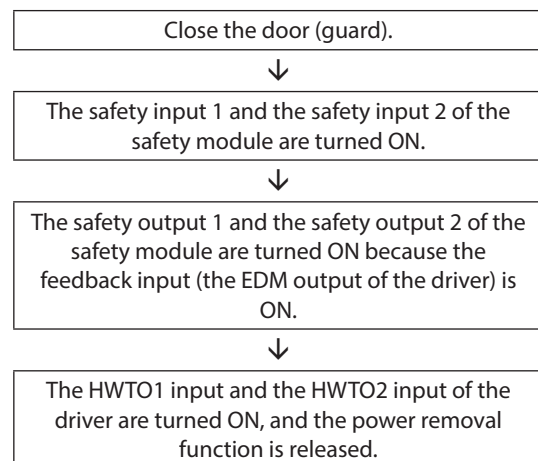

■ How to detect a failure

If a failure that the HWTO1 input or the HWTO2 input is not turned OFF occurs, the EDM output is not turned ON. A failure can be detected because the safety module is not reset even if the door (guard) is closed and the motor cannot be started.

6-6 Verification testing of power removal function

- Be sure to perform the verification testing of the power removal function when starting up or maintaining the equipment, or when replacing the driver.
- According to use conditions of the safety related parts of a control system, perform a verification testing of the power removal function at least once three months.
- Keep the verification result on record.

■ Description of verification testing

1. Turn on the control power supply and main power supply of the driver while both the HWTO1 and HWTO2 inputs are an ON state.
2. Use the MainDevice to input the excitation command.
3. Check that the motor is in an excitation state and the EDM output is in an OFF state.
4. Turn both the HWTO1 and HWTO2 inputs OFF.
5. Check that the motor goes into a non-excitation state and the EDM output is turned ON.

6-7 Related functions

Note The related functions are not safety-related parts of a control system.

● ETO-CLR input

If the ETO-CLR input is turned ON after both the HWTO1 and HWTO2 inputs are turned ON to release the power removal function, the motor puts into a state possible to excite.

Related object

Index	Name	Description	Initial value
4199h	ETO reset action (ETO-CLR)	Sets the judgment level of the signal when the motor is put into a state possible to excite by the ETO-CLR input. [Setting range] 1: Activate at ON edge 2: Activate at ON level	1

● HWTOIN-MON output

If the HWTO1 input or the HWTO2 input is turned OFF, the HWTOIN-MON output is turned ON.

● ETO-MON output

If the HWTO1 input or the HWTO2 input is turned OFF when the "HWTO mode selection (4190h)" is set to "0: Alarm is not present," the ETO-MON output is turned ON. If the motor is put into a state possible to excite by the ETO-CLR input after both the HWTO1 and HWTO2 inputs are turned ON, the ETO-MON output is turned OFF.

Related object

Index	Name	Description	Initial value
4190h	HWTO mode selection	Generates an alarm when the HWTO1 input or the HWTO2 input is turned OFF. [Setting range] 0: Alarm is not present 1: Alarm is present	0

● EDM-MON output

If both the HWTO1 and HWTO2 inputs are turned OFF, the EDM-MON output is turned ON.

Note Be sure to use the EDM output of CN1 to detect the failure of the power removal function.

● Alarm of HWTO input detection

If the "HWTO mode selection (4190h)" is set to "1: Alarm is present," an alarm will be generated when either the HWTO1 input or the HWTO2 input is turned OFF. (HWTO input detection, alarm code 68h)

At this time, the PWR/ALM LED blinks once in red repeatedly.

When the "HWTO mode selection (4190h)" is set to "1: Alarm is present," the motor will put into a state possible to excite if the ALM-RST input is turned from OFF to ON after the power removal function is released. (It is enabled at the ON edge.)

Related object

Index	Name	Description	Initial value
4190h	HWTO mode selection	Generates an alarm when the HWTO1 input or the HWTO2 input is turned OFF. [Setting range] 0: Alarm is not present 1: Alarm is present	0

● Alarm of HWTO input circuit error

If a time after either the HWTO1 input or the HWTO2 input is turned OFF until the other input is turned OFF exceeds the value set in the "HWTO delay time of checking dual system (4191h)," an alarm will be generated. (HWTO input circuit error, alarm code 53h)

At this time, the PWR/ALM LED blinks twice in red repeatedly.

Related object

Index	Name	Description	Initial value
4191h	HWTO delay time of checking dual system	If a time after either the HWTO1 input or the HWTO2 input is turned OFF until the other input is turned OFF exceeds the value set in this object, an alarm will be generated. [Setting range] 0 to 10 (disable), 11 to 100 ms	0

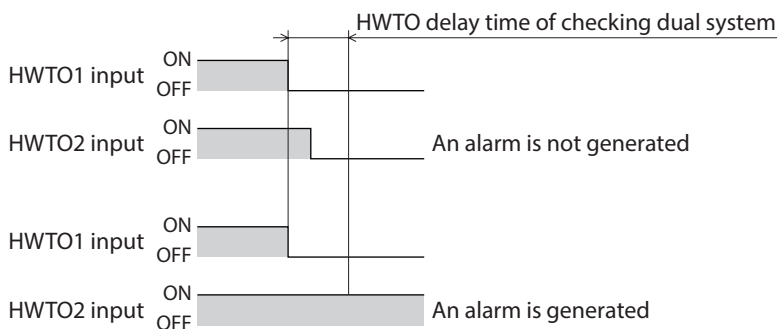

● ETO reset ineffective period

The motor will not put into a state possible to excite until the time set in the "ETO reset ineffective period (4198h)" is elapsed even if the ETO-CLR input is turned ON.

Related object

Index	Name	Description	Initial value
4198h	ETO reset ineffective period	Sets a time when the ETO-CLR input is disabled if the motor is put into a state possible to excite by the ETO-CLR input after the HWTO1 input and the HWTO2 input are turned ON. The motor will not put into a state possible to excite until the time set in this object is exceeded even if the ETO-CLR input is turned ON. [Setting range] 0 to 100 ms	0

When the ETO-CLR input is turned ON before the time set in the “ETO reset ineffective period (4198h)” is elapsed (when the motor is put into a state possible to excite at the ON edge of the input)

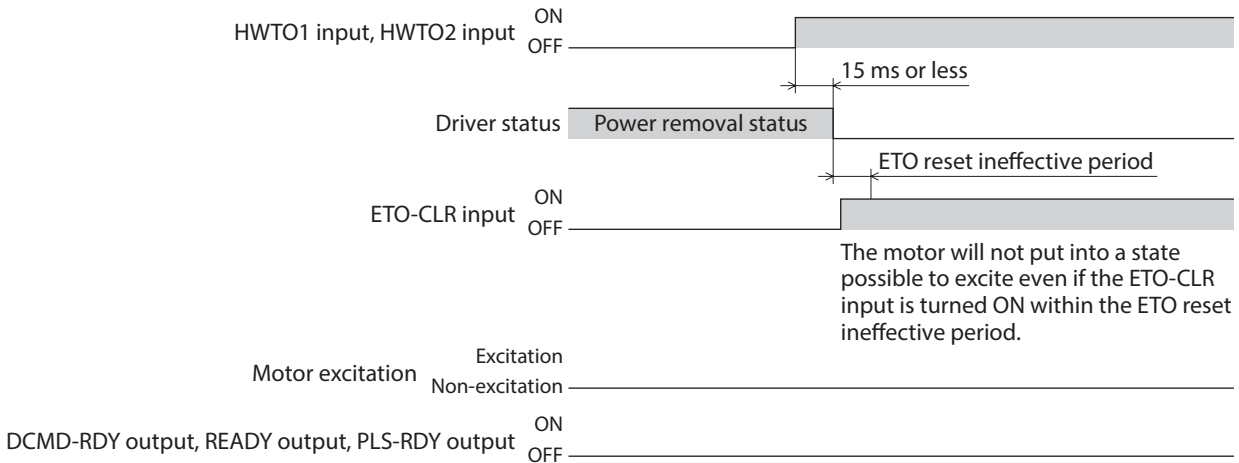

When the ETO-CLR input is turned ON after the time set in the “ETO reset ineffective period (4198h)” is elapsed (when the motor is put into a state possible to excite at the ON edge of the input)

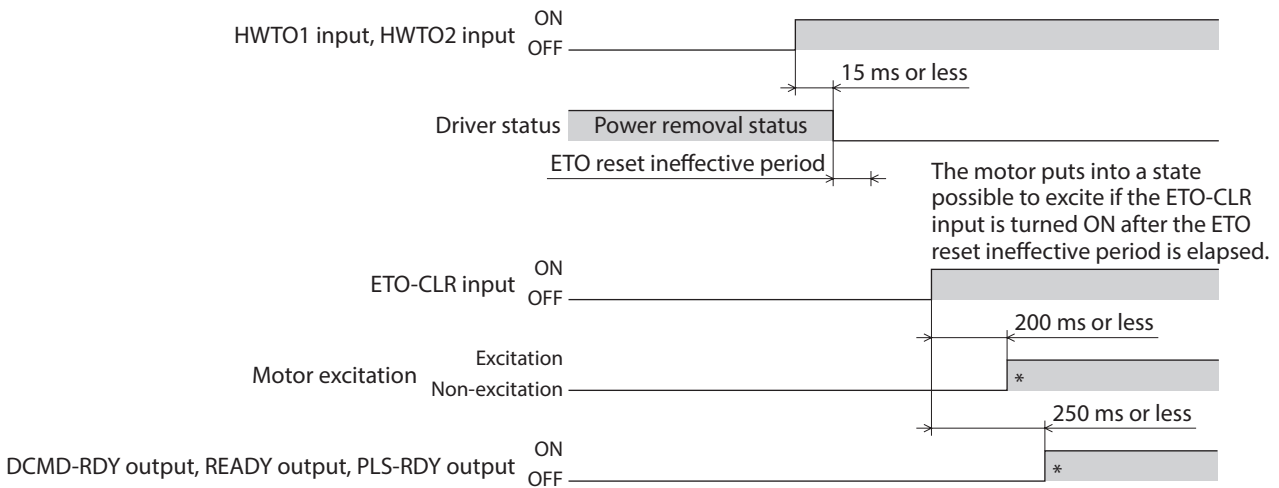

* It is the movement when the excitation command is input from the MainDevice at the time the ETO-CLR input is turned ON.

● **Signal judgment level of ETO-CLR input**

If the “ETO reset action (ETO-CLR) (4199h)” is set to “2: Activate at ON level,” the motor will put into a state possible to excite at the ON level of the ETO-CLR input instead of the ON edge. (Initial value: Activate at ON edge)

Related object

Index	Name	Description	Initial value
4199h	ETO reset action (ETO-CLR)	Sets the judgment level of the signal when the motor is put into a state possible to excite by the ETO-CLR input. [Setting range] 1: Activate at ON edge 2: Activate at ON level	1

- **Motor excitation by input signals other than ETO-CLR input**

Changing the parameter can add a function to put the motor into a state possible to excite by the ALM-RST input and the STOP input. In the initial value, this function is set to the STOP input only.

Related objects

Index	Name	Description	Initial value
419Ah	ETO reset action (ALM-RST)	The motor is put into a state possible to excite by the ALM-RST input after the HWTO1 input and the HWTO2 input are turned ON. [Setting range] 0: Disable 1: Activate at ON edge	0
419Ch	ETO reset action (STOP)	The motor is put into a state possible to excite by the STOP input after the HWTO1 input and the HWTO2 input are turned ON. [Setting range] 0: Disable 1: Activate at ON edge	1

7 Inspection and maintenance

7-1 Inspection

It is recommended that periodic inspections are conducted for the items listed below after each operation of the motor. If an abnormal condition is noted, discontinue any use and contact your nearest Oriental Motor sales office.

■ Inspection item

- Check if the openings in the driver are clogged.
- Check if the installation place of the driver is loose.
- Check if any of the connection parts of the driver is loose.
- Check if dust is deposited on the driver.
- Check if the driver has unusual smells or appearance defects.



The driver uses semiconductor components. Static electricity may damage the semiconductor components of the driver, so be extremely careful when handling the driver.

7-2 Warranty

Check on the Oriental Motor Website for the product warranty.

7-3 Disposal

Dispose the product correctly in accordance with laws and regulations, or instructions of local governments.

8 Cables

8-1 Connection cable (For cable type)

■ Connection cable set/Flexible connection cable set

These cables are used when connecting a motor and a driver. It is a set of two cables for the motor and the encoder. For the cable set of electromagnetic brake motors, a set of three cables for the motor, the encoder, and the electromagnetic brake is provided.

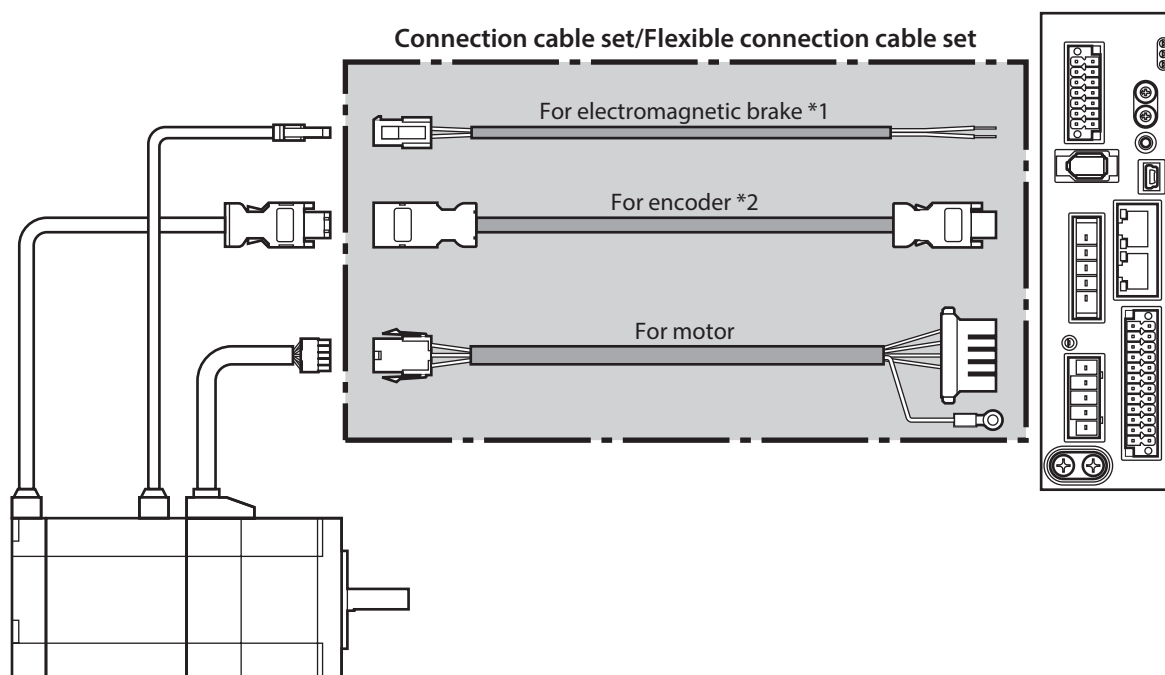

*1 Only when the motor is the electromagnetic brake type.

*2 Use the cable for encoder when the length of the encoder cable of motor is not enough.

memo When installing the motor on a moving part, use a flexible cable.

● Connection cable set

For motor/encoder

Model	Length [m (ft.)]
CC005VZF	0.5 (1.6)
CC010VZF	1 (3.3)
CC015VZF	1.5 (4.9)
CC020VZF	2 (6.6)
CC025VZF	2.5 (8.2)
CC030VZF	3 (9.8)
CC040VZF	4 (13.1)
CC050VZF	5 (16.4)
CC070VZF	7 (23.0)
CC100VZF	10 (32.8)
CC150VZF	15 (49.2)
CC200VZF	20 (65.6)

For motor/encoder/electromagnetic brake

Model	Length [m (ft.)]
CC005VZFB	0.5 (1.6)
CC010VZFB	1 (3.3)
CC015VZFB	1.5 (4.9)
CC020VZFB	2 (6.6)
CC025VZFB	2.5 (8.2)
CC030VZFB	3 (9.8)
CC040VZFB	4 (13.1)
CC050VZFB	5 (16.4)
CC070VZFB	7 (23.0)
CC100VZFB	10 (32.8)
CC150VZFB	15 (49.2)
CC200VZFB	20 (65.6)

● Flexible connection cable set

For motor/encoder

Model	Length [m (ft.)]
CC005VZR	0.5 (1.6)
CC010VZR	1 (3.3)
CC015VZR	1.5 (4.9)
CC020VZR	2 (6.6)
CC025VZR	2.5 (8.2)
CC030VZR	3 (9.8)
CC040VZR	4 (13.1)
CC050VZR	5 (16.4)
CC070VZR	7 (23.0)
CC100VZR	10 (32.8)
CC150VZR	15 (49.2)
CC200VZR	20 (65.6)

For motor/encoder/electromagnetic brake

Model	Length [m (ft.)]
CC005VZRB	0.5 (1.6)
CC010VZRB	1 (3.3)
CC015VZRB	1.5 (4.9)
CC020VZRB	2 (6.6)
CC025VZRB	2.5 (8.2)
CC030VZRB	3 (9.8)
CC040VZRB	4 (13.1)
CC050VZRB	5 (16.4)
CC070VZRB	7 (23.0)
CC100VZRB	10 (32.8)
CC150VZRB	15 (49.2)
CC200VZRB	20 (65.6)

■ Extension cable set/Flexible extension cable set

These cables are used when extending the connection cable.

Use if the length of the connection cable used is not enough when extending the distance between a motor and a driver.

It is a set of two cables for the motor and the encoder. For the cable set of electromagnetic brake motors, a set of three cables for the motor, the encoder, and the electromagnetic brake is provided.

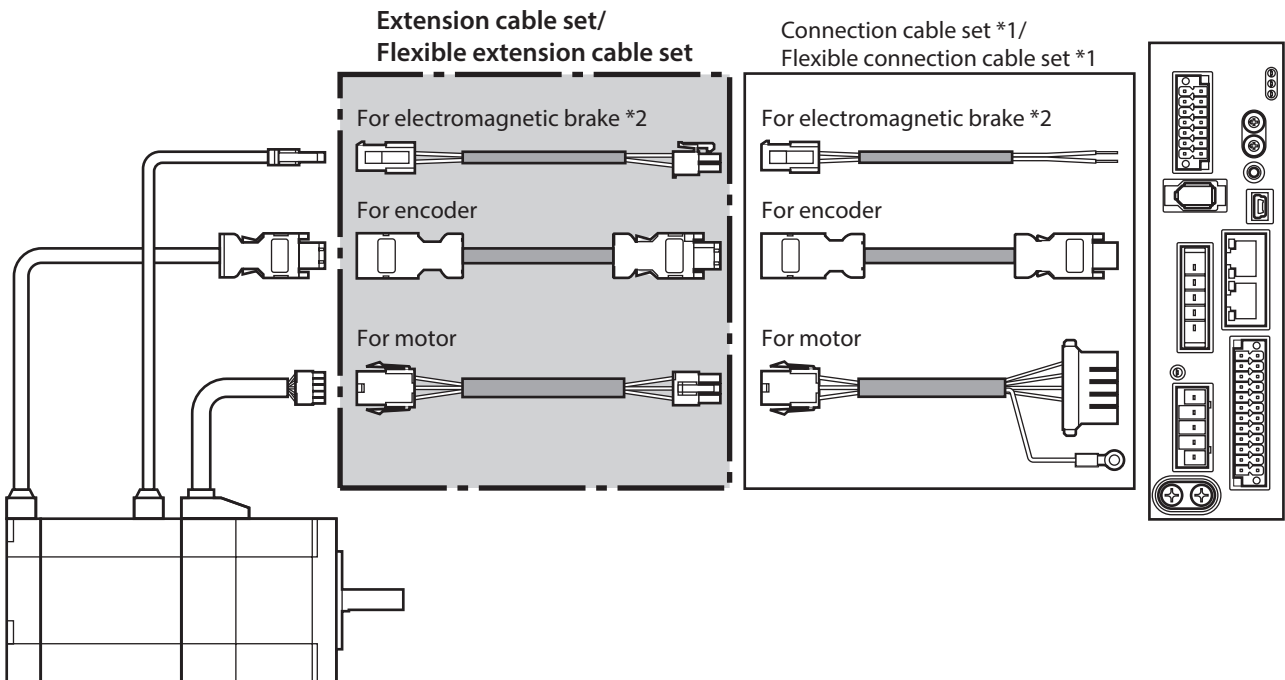

*1 Use the connection cable used.

*2 Only when the motor is of electromagnetic brake type.



- When installing the motor on a moving part, use a flexible cable.
- When extending the wiring length by connecting an extension cable to the connection cable, keep the total cable length to 20 m (65.6 ft.) or less.

- **Extension cable set**

For motor/encoder

Model	Length [m (ft.)]
CC010VZFT	1 (3.3)
CC020VZFT	2 (6.6)
CC030VZFT	3 (9.8)
CC050VZFT	5 (16.4)
CC070VZFT	7 (23.0)
CC100VZFT	10 (32.8)
CC150VZFT	15 (49.2)

For motor/encoder/electromagnetic brake

Model	Length [m (ft.)]
CC010VZFBT	1 (3.3)
CC020VZFBT	2 (6.6)
CC030VZFBT	3 (9.8)
CC050VZFBT	5 (16.4)
CC070VZFBT	7 (23.0)
CC100VZFBT	10 (32.8)
CC150VZFBT	15 (49.2)

- **Flexible extension cable set**

For motor/encoder

Model	Length [m (ft.)]
CC010VZRT	1 (3.3)
CC020VZRT	2 (6.6)
CC030VZRT	3 (9.8)
CC050VZRT	5 (16.4)
CC070VZRT	7 (23.0)
CC100VZRT	10 (32.8)
CC150VZRT	15 (49.2)

For motor/encoder/electromagnetic brake

Model	Length [m (ft.)]
CC010VZRBT	1 (3.3)
CC020VZRBT	2 (6.6)
CC030VZRBT	3 (9.8)
CC050VZRBT	5 (16.4)
CC070VZRBT	7 (23.0)
CC100VZRBT	10 (32.8)
CC150VZRBT	15 (49.2)

8-2 Connection cables (For connector type)

■ Connection cable/Flexible connection cable

These cables are used when connecting a motor and a driver.

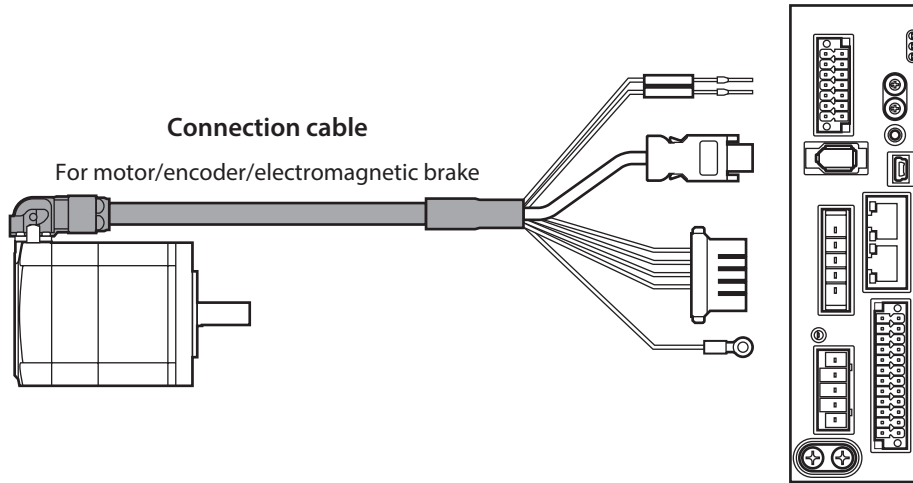

The model name of the connection cable varies depending on the outlet direction from the motor. Refer to the figures.

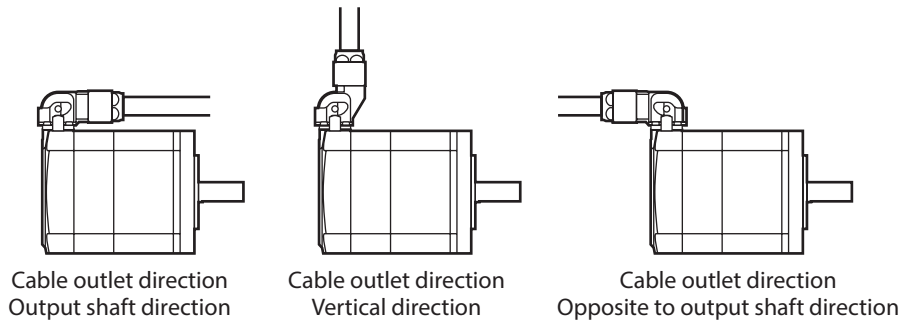

When installing the motor on a moving part, use a flexible cable.

● Connection cable

For motor/encoder

Length [m (ft.)]	Cable outlet direction		
	Output shaft direction	Vertical direction	Opposite to output shaft direction
1 (3.3)	CCM010Z1AFF	CCM010Z1AVF	CCM010Z1ABF
2 (6.6)	CCM020Z1AFF	CCM020Z1AVF	CCM020Z1ABF
3 (9.8)	CCM030Z1AFF	CCM030Z1AVF	CCM030Z1ABF
5 (16.4)	CCM050Z1AFF	CCM050Z1AVF	CCM050Z1ABF
7 (23.0)	CCM070Z1AFF	CCM070Z1AVF	CCM070Z1ABF
10 (32.8)	CCM100Z1AFF	CCM100Z1AVF	CCM100Z1ABF

For motor/encoder/electromagnetic brake

Length [m (ft.)]	Cable outlet direction		
	Output shaft direction	Vertical direction	Opposite to output shaft direction
1 (3.3)	CCM010Z1BFF	CCM010Z1BVF	CCM010Z1BBF
2 (6.6)	CCM020Z1BFF	CCM020Z1BVF	CCM020Z1BBF
3 (9.8)	CCM030Z1BFF	CCM030Z1BVF	CCM030Z1BBF
5 (16.4)	CCM050Z1BFF	CCM050Z1BVF	CCM050Z1BBF
7 (23.0)	CCM070Z1BFF	CCM070Z1BVF	CCM070Z1BBF
10 (32.8)	CCM100Z1BFF	CCM100Z1BVF	CCM100Z1BBF

● **Flexible connection cable****For motor/encoder**

Length [m (ft.)]	Cable outlet direction		
	Output shaft direction	Vertical direction	Opposite to output shaft direction
1 (3.3)	CCM010Z1AFR	CCM010Z1AVR	CCM010Z1ABR
2 (6.6)	CCM020Z1AFR	CCM020Z1AVR	CCM020Z1ABR
3 (9.8)	CCM030Z1AFR	CCM030Z1AVR	CCM030Z1ABR
5 (16.4)	CCM050Z1AFR	CCM050Z1AVR	CCM050Z1ABR
7 (23.0)	CCM070Z1AFR	CCM070Z1AVR	CCM070Z1ABR
10 (32.8)	CCM100Z1AFR	CCM100Z1AVR	CCM100Z1ABR

For motor/encoder/electromagnetic brake

Length [m (ft.)]	Cable outlet direction		
	Output shaft direction	Vertical direction	Opposite to output shaft direction
1 (3.3)	CCM010Z1BFR	CCM010Z1BVR	CCM010Z1BBR
2 (6.6)	CCM020Z1BFR	CCM020Z1BVR	CCM020Z1BBR
3 (9.8)	CCM030Z1BFR	CCM030Z1BVR	CCM030Z1BBR
5 (16.4)	CCM050Z1BFR	CCM050Z1BVR	CCM050Z1BBR
7 (23.0)	CCM070Z1BFR	CCM070Z1BVR	CCM070Z1BBR
10 (32.8)	CCM100Z1BFR	CCM100Z1BVR	CCM100Z1BBR

8-3 I/O signal cable

This is a shielded cable for good noise immunity to connect the I/O signals of the host controller to the driver. The ground wire useful to grounding is extracted from both ends of the cable. A connector is assembled at the driver side.

Model	Cable length [m (ft.)]	Number of lead wire cores
CC24D005C-1	0.5 (1.6)	24 pcs.
CC24D010C-1	1 (3.3)	
CC24D020C-1	2 (6.6)	

9 Accessories

9-1 Pulse signal converter for noise immunity

This product converts a pulse signal, which is output from the open collector output, to a pulse signal for good noise immunity by outputting the pulse signal again from the differential output.

Model: **VCS06**

9-2 Relay contact protection circuit/module

- **CR circuit for surge suppression**

This product is effective to suppress the surge which occurs in a relay contact part. Use it to protect the contacts of the relay or switch.

Model: **EPCR1201-2**

- **CR circuit module**

This product is effective to suppress the surge which occurs in a relay contact part. Use it to protect the contacts of the relay or switch.

Four pieces of CR circuit for surge suppression are mounted on the compact circuit, and this product can be installed to the DIN rail. This product can make the wiring easily and securely since it also supports terminal block connection.

Model: **VCS02**

9-3 Regeneration resistor

If vertical drive (gravitational operation) such as elevator applications is performed or if sudden start-stop operation of a large inertia is repeated frequently, connect the regeneration resistor.

Be sure to connect if an alarm or information of "Overvoltage" was generated.

Model: **RGB100**

3 DC power input type

This part explains contents specific to the DC power input type driver.

◆Table of contents

1	System configuration.....	58	5	Setting of node address	78
2	Preparation	59	5-1	Setting method	78
2-1	Checking the product	59	6	Power removal function	79
2-2	How to identify the product model	59	6-1	Safety parameters.....	79
2-3	Products possible to combine	59	6-2	Notes when using the power removal function.....	80
2-4	Information about nameplate	60	6-3	I/O signals	80
2-5	Names and functions of parts.....	60	6-4	Operation of power removal function....	81
2-6	Indication of LEDs.....	62	6-5	Example of use.....	84
3	Installation	63	6-6	Verification testing of power removal function.....	85
3-1	Installation location	63	6-7	Related functions.....	85
3-2	Installation method	63	7	Inspection and maintenance	89
4	Connection	65	7-1	Inspection.....	89
4-1	Connection example	65	7-2	Warranty.....	89
4-2	Connecting the control power supply....	66	7-3	Disposal.....	89
4-3	Connecting the main power supply and grounding	67	8	Cables	90
4-4	Connecting the EtherCAT communication cable	69	8-1	Connection cable (For cable type)	90
4-5	Connecting the USB cable.....	70	8-2	Connection cables (For connector type)	94
4-6	Connecting the I/O signals.....	70	8-3	I/O signal cable	96
4-7	Noise elimination measures	75	9	Accessories.....	97
4-8	Conformity to the EMC Directive/ Regulations	76	9-1	Pulse signal converter for noise immunity	97
			9-2	Relay contact protection circuit/ module	97

1 System configuration

3 DC power input type

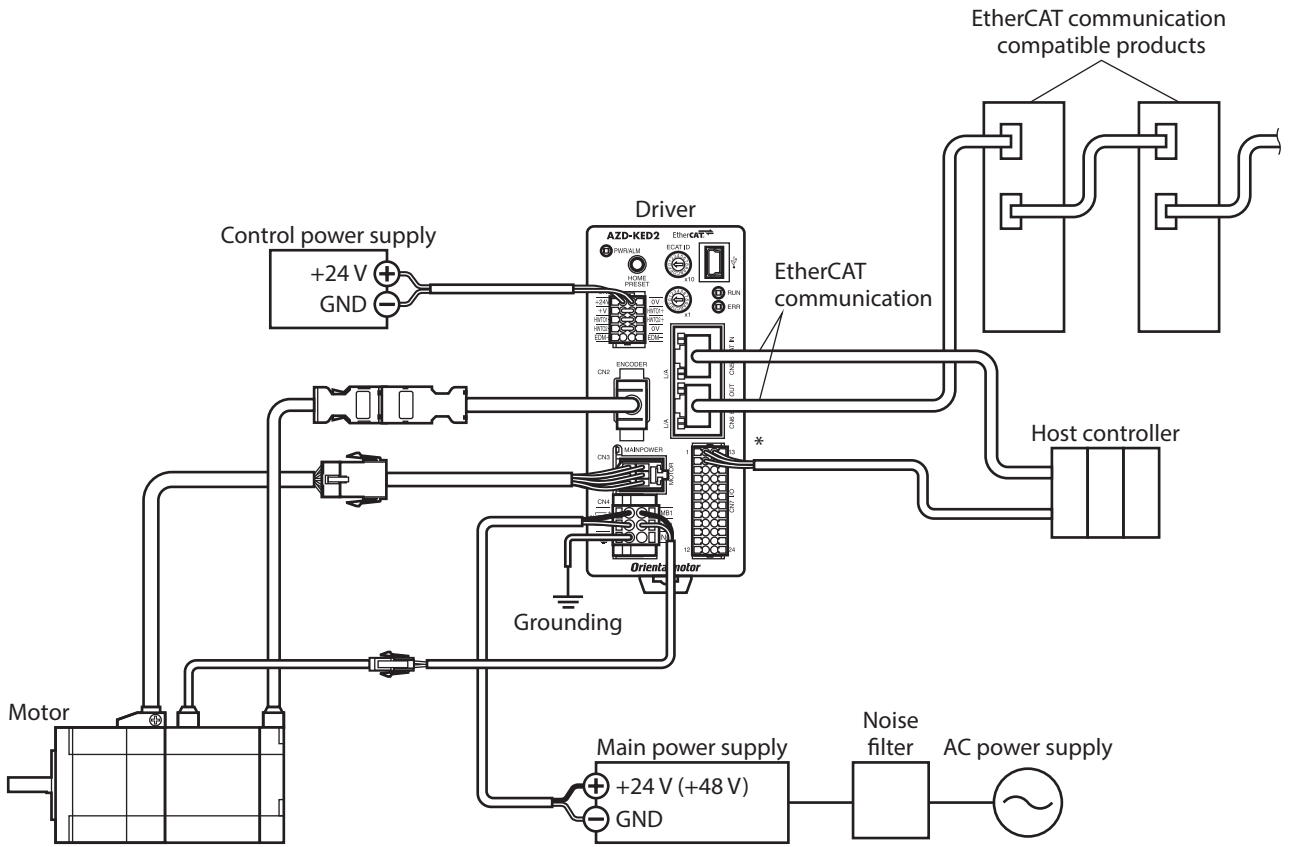

* Connect when using direct I/O or sensors.

2 Preparation

This chapter explains the items you should check, as well as names and functions of each part.

2-1 Checking the product

Verify that the items listed below are included. Report any missing or damaged items to the Oriental Motor sales office from which you purchased the product.

- Driver 1 unit
- CN1 connector (10 pins) 1 pc.
- CN4 connector (6 pins) 1 pc.
- CN7 connector (24 pins) 1 pc.
- Instructions and Precautions for Safe Use 1 copy

Included connector model

Type	Part number	Manufacturer
CN1 connector	DFMC0,5/5-ST-2,54	PHOENIX CONTACT GmbH & Co. KG
CN4 connector	DFMC1,5/3-ST-3,5-LR	PHOENIX CONTACT GmbH & Co. KG
CN7 connector	DFMC0,5/12-ST-2,54	PHOENIX CONTACT GmbH & Co. KG

2-2 How to identify the product model

Check the model name of the driver against the number shown on the nameplate. Refer to p.60 for how to identify the nameplate.

AZD - K ED 2
 1 2 3 4

1	Series	AZD: AZ Series driver
2	Power supply input	K: 24/48 VDC
3	Network type	ED: EtherCAT Compatible
4	Reference number	

2-3 Products possible to combine

Products with which the driver can be combined are listed below. Check the model name of the product with the nameplate.

Power supply type	Product type	Applicable series	Model name representing series name *1	Example of model name
DC input	Stepping motor	AZ Series	AZM	AZM46AK AZM66AK-TS10
		EAS Series *2	EASM	EASM4NXD005AZAK
	Motorized actuator	EAC Series *2	EACM	EACM2E05AZAK
		EZS Series *2	EZSM	EZSM6D005AZAK
		DR Series	DR	DR28G2.5B03-AZAKU DR28T1B03-AZAKD-F
		DRS2 Series	DRSM	DRSM60-05A4AZAK
		DGII Series	DGM DGB	DGM85R-AZAK DGB85R12-AZAKR
		EH Series	EH	EH4-AZAKH
		L Series	LM	LM4F150AZAK-1

*1 The driver described in this manual can be combined with products that begin with these model names.

*2 For these motorized actuators, the equipped motors have been evaluated to affix the CE Marking. Check the model name of the equipped motor with the nameplate.

2-4 Information about nameplate

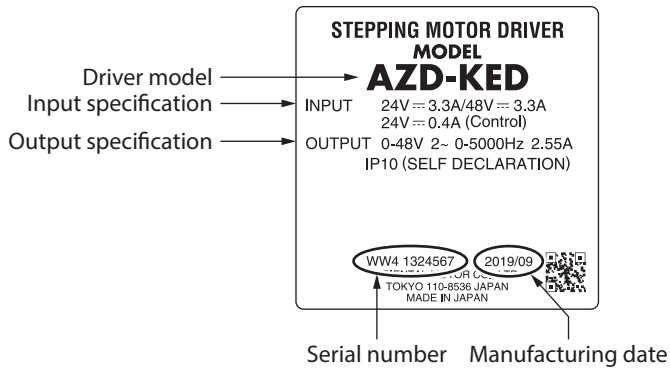

The figure shows an example.

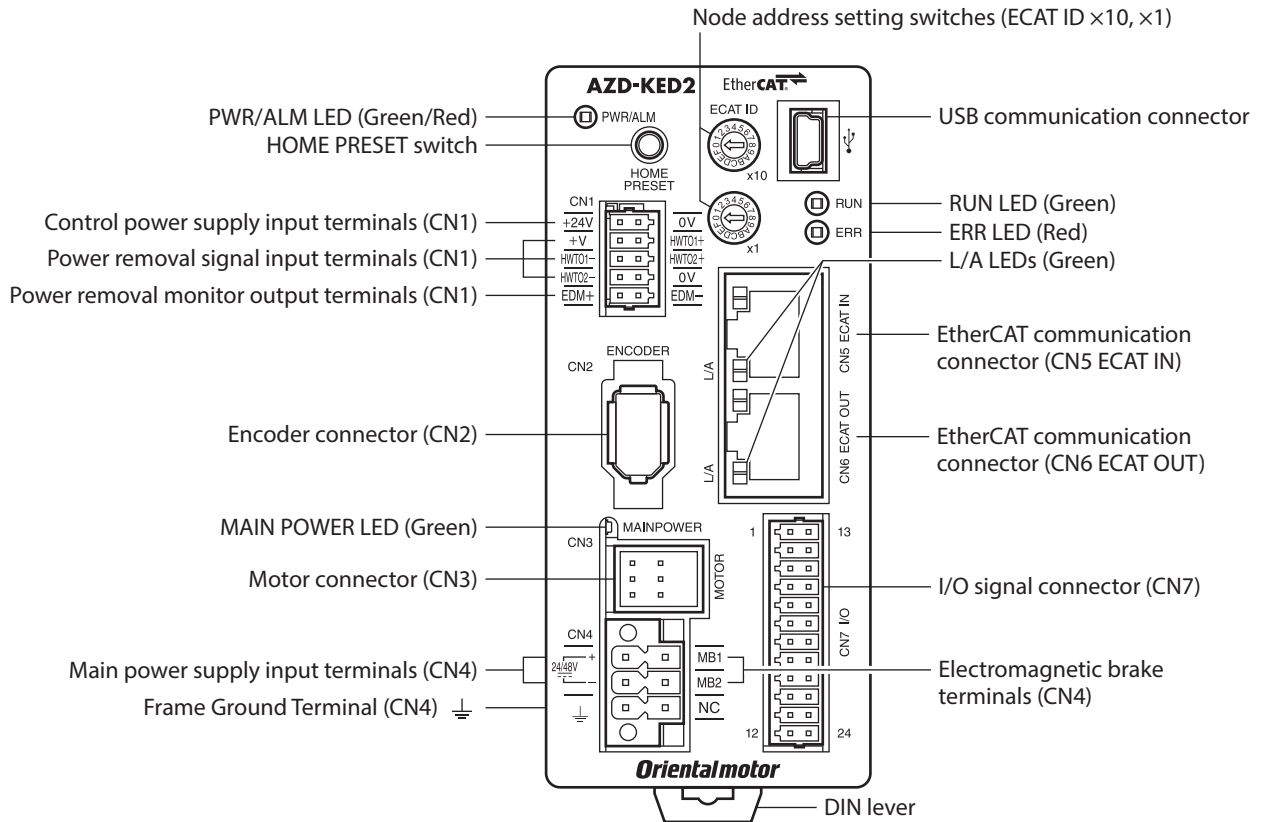

The position describing the information may vary depending on the product.

2-5 Names and functions of parts



Type	Name	Sign	Description
LED	PWR/ALM LED (Green/Red)	PWR/ALM	<ul style="list-style-type: none"> This LED is lit in green while the control power supply is turned on. If an alarm (protective function) is generated, the LED will blink in red. If the power removal function (p.79) is triggered, the LED will blink in green. If information is generated, the LED will simultaneously blink in green and red twice. (Green and red colors may overlap and it may be visible to orange.)
	MAIN POWER LED (Green)	MAIN POWER	This LED is lit in green while the main power supply is turned on.
	RUN LED (Green)	RUN	This LED indicates the status of EtherCAT communication.
	ERR LED (Red)	ERR	This LED blinks when an error occurred via EtherCAT communication.
	L/A LEDs (Green)	L/A	These LEDs indicate the LINK/ACT status of EtherCAT communication.
Switch	Node address setting switches	ECAT ID ×10 ECAT ID ×1	Used to set the node address. Factory setting: 00 (×10: 0, ×1: 0)
	HOME PRESET switch	HOME PRESET	Used to set the starting position (home) when positioning operation is performed.
Connector	Encoder connector (CN2)	ENCODER	Connects the encoder.
	Motor connector (CN3)	MOTOR	Connects the motor.
	USB communication connector		Connects a PC in which the MEXE02 has been installed. (USB2.0 mini-B port)
	EtherCAT communication connector (CN5)	ECAT IN	Connects with the upper EtherCAT communication compatible product.
	EtherCAT communication connector (CN6)	ECAT OUT	Connects with the EtherCAT communication compatible product of the following node address.
	I/O signal connector (CN7)	I/O	Connects when using direct I/O or sensors.
Terminal	Control power supply input terminals (CN1)	+24V, 0V	Connects the control power supply.
	Power removal signal input terminals (CN1)	HWT01+, HWT01– HWT02+, HWT02–	Connects the external device.
	Power removal monitor output terminals (CN1)	EDM+, EDM–	
	Main power supply input terminals (CN4)	+, –	Connects the main power supply.
	Electromagnetic brake terminals (CN4)	MB1, MB2	Connects the lead wires from the electromagnetic brake.
	Frame Ground Terminal (CN4)		Ground using a grounding wire of AWG24 to 16 (0.2 to 1.25 mm ²).
Other	DIN lever	–	This is used to install the driver to a DIN rail.

2-6 Indication of LEDs

LED indication related to driver status

PWR/ALM LED status		Description
Green	Red	
Unlit	Unlit	The control power supply is not turned on.
Lit	Unlit	The control power supply is turned on.
Unlit	Blinking	An alarm is being generated. Details about the generated alarm can be checked by counting the number of times the LED blinks. The LED is lit in green when the alarm is reset.
Blinking	Unlit	The power removal function has been activated. After the power removal function is released, the LED is lit in green when the ETO-CLR input is turned ON.
Blinking twice at the same time *		<ul style="list-style-type: none"> Information is being generated. The LED is lit in green when the information is cleared. Remote operation is being executed with the MEXE02. The LED is lit in green when remote operation is complete.
Blinking at the same time *		The interlock was released by holding down the HOME PRESET switch. The LED is lit in green when the time set in the "Extended input (EXT-IN) interlock releasing duration (4973h)" is elapsed.
Lit at the same time *		The input signal assigned to the HOME PRESET switch is being executed. The LED is lit in green when it is complete.
Repeating "Green → Red → Simultaneously lit → Unlit"		This is the driver simulation mode.

* Green and red colors may overlap and it may be visible to orange.

LED indication related to EtherCAT communication status

LED indicator	LED status	Description
RUN (Green)	Unlit	Initialization state
	Blinking *	Pre-Operational state
	Single flash *	Safe-Operational state
	Lit	Operational state (normal condition)
ERR (Red)	Unlit	No communication error
	Blinking *	Communication setting error
	Single flash *	Communication data error
	Double flash *	Communication watchdog timeout
L/A (Green)	Unlit	No link
	Lit	Link establishment
	Flickering *	Operation in progress after link establishment

* The timing to blink the LED is as follows. (unit: ms)

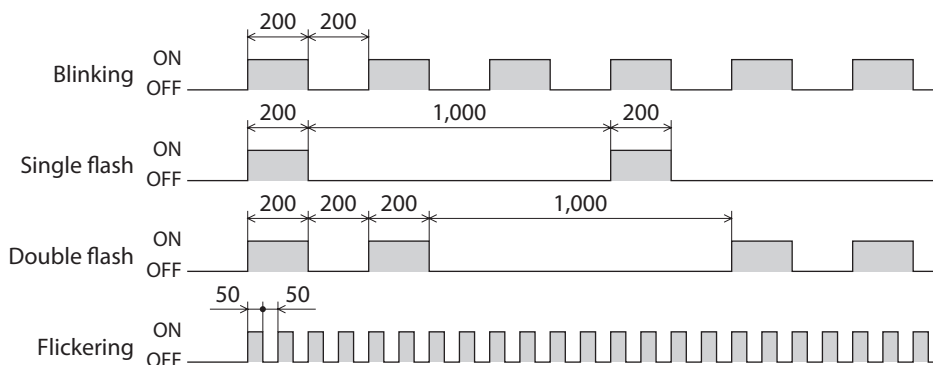

3 Installation

This chapter explains the installation location and installation method of the driver.

3-1 Installation location

The driver is designed and manufactured to be incorporated in equipment. Install it in a well-ventilated location that provides easy access for inspection. The location must also satisfy the following conditions:

- Inside an enclosure that is installed indoors (provide vent holes)
- Operating ambient temperature: 0 to +50 °C (+32 to +122 °F) (non-freezing)
- Operating ambient humidity: 85 % or less (non-condensing)
- Area free of explosive atmosphere, toxic gas (such as sulfuric gas), or liquid
- Area not exposed to direct sun
- Area free of excessive amount of dust, iron particles or the like
- Area not subject to splashing water (rain, water droplets), oil (oil droplets), or other liquids
- Area free of excessive salt
- Area not subject to continuous vibrations or excessive shocks
- Area free of excessive electromagnetic noise (from welders, power machinery, etc.)
- Area free of radioactive materials, magnetic fields or vacuum
- Up to 1,000 m (3,300 ft.) above sea level

3-2 Installation method

Mount the driver to a 35 mm (1.38 in.) width DIN rail.

When installing two or more drivers in parallel, it is possible to install them closely in the horizontal direction. Provide a minimum clearance of 50 mm (1.97 in.) in the vertical direction.

When installing three or more drivers closely, the heat generation of the inside drivers become high. Install the less frequently used drivers toward the inside. Also, use the drivers in conditions that an ambient temperature is 0 to +40 °C (+32 to +104 °F) and the stop current is 50 % or less.

Note

- Do not install any equipment that generates a large amount of heat or noise near the driver.
- Do not install the driver underneath the host controller or other equipment vulnerable to heat.
- If the ambient temperature of the driver exceeds 50 °C (122 °F), reconsider the ventilation condition such as providing forced cooling by using fans or creating spaces between the drivers.
- Be sure to install the driver vertically (in vertical position).

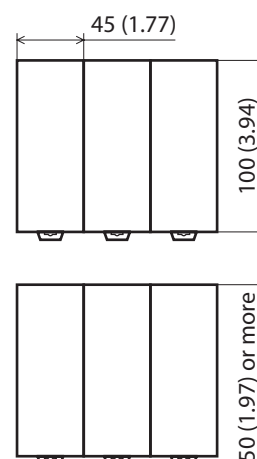

Unit: mm (in.)

■ Installing to DIN rail

1. Pull down the DIN lever of the driver and lock it. Hang the hook at the rear to the DIN rail.
2. Hold the driver to the DIN rail, and push up the DIN lever to secure.
3. Secure both sides using end plates.

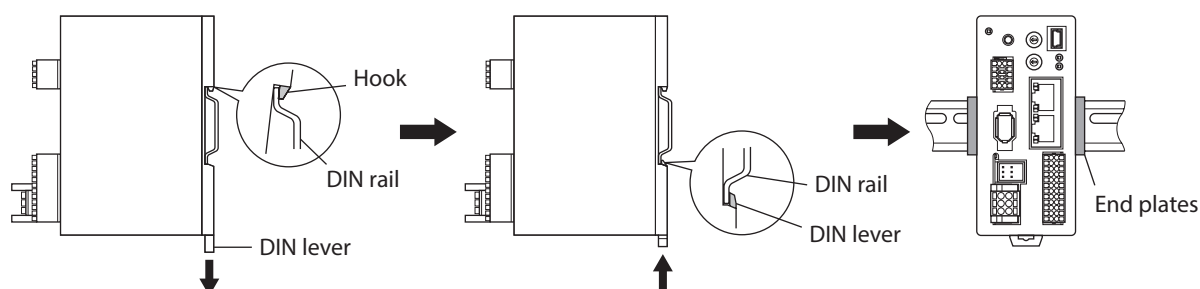

Removing from DIN rail

Pull the DIN lever down until it locks using a slotted screwdriver, and lift the bottom of the driver to remove it from the rail. Use force of about 10 to 20 N (2.2 to 4.5 lb.) to pull the DIN lever to lock it. Excessive force may damage the DIN lever.

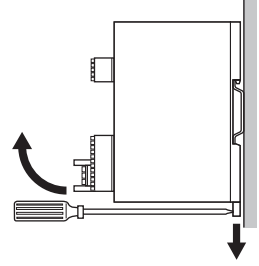

■ Dimensions

- Unit: mm (in.)
- Mass: 0.18 kg (0.4 lb.)

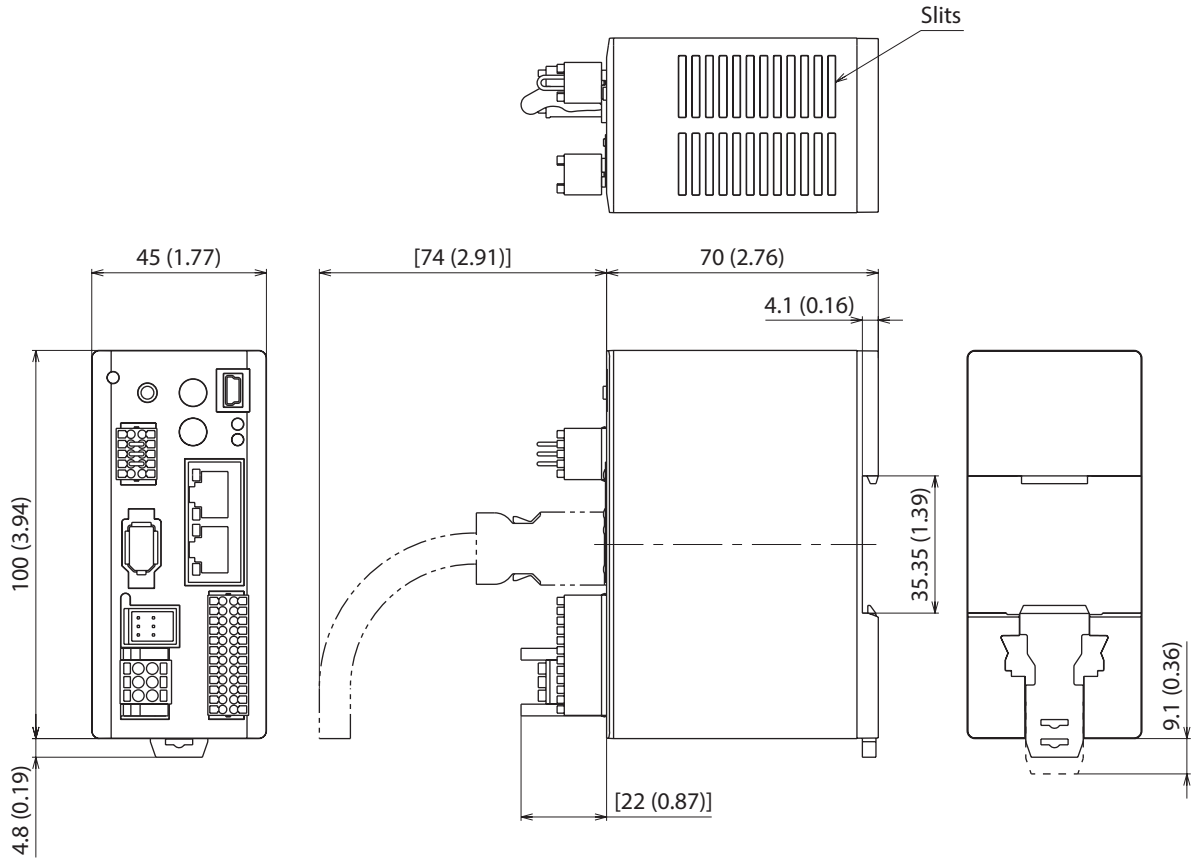

4 Connection

This chapter explains a connection example of a driver and a motor, connection methods of power supplies, the grounding method, and others.

The installation and wiring methods in compliance with the EMC Directive/Regulations as well as protection against noise are also explained.

4-1 Connection example

Use connection cables of Oriental Motor to connect the motor. Check the cable models on p.90. The figure shows an example when the cable type electromagnetic brake motor is used.

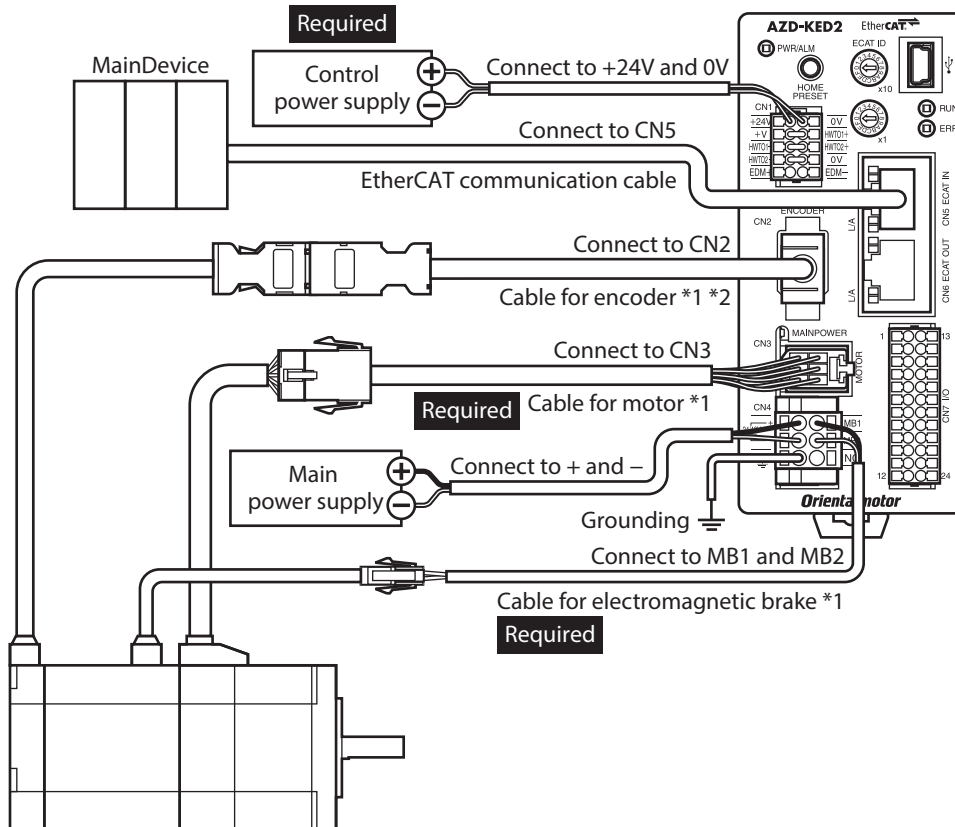

*1 These cables are provided as our products. Purchase it separately.

*2 Use the cable for encoder when the length of the encoder cable of motor is not enough.

Note

- Connect the connectors securely. Insecure connections may cause malfunction or damage to the motor or the driver.
- The lead wires of the "cable for electromagnetic brake" have polarities, so connect them in the correct polarities. If the lead wires are connected with their polarities reversed, the electromagnetic brake will not operate properly.
- Do not wire the power supply cable of the driver in the same cable duct with other power lines or motor cable. Doing so may cause malfunction due to noise.
- Keep the wiring distance between the motor and the driver equal to or less than the following values. Exceeding the following wiring distance may cause the driver to generate heat or increase the electrical noise emitted from the product.
Cable type: 20 m (65.6 ft.)
Connector type: 10 m (32.8 ft.)

3 DC power input type



- Before connecting or disconnecting a connector, turn off the main power supply and the control power supply, and check the PWR/ALM LED and the MAIN POWER LED have been turned off.
- When pulling off the motor cable, do so while pressing the latches on the connector with fingers.
- When installing the motor on a moving part, use a flexible cable. Refer to p.90 for the model name.

■ **Electrical wire size**

Connector	Terminal symbol	Recommended wire size
CN1	+24V, 0V, HWTO1+, HWTO1-, HWTO2+, HWTO2-, EDM+, EDM-	Stranded wire or solid wire AWG26 to 20 (0.14 to 0.5 mm ²)
CN4	+, -, MB1, MB2, $\underline{\text{⏏}}$	Stranded wire or solid wire AWG24 to 16 (0.2 to 1.25 mm ²)
CN7	-	Stranded wire or solid wire AWG26 to 20 (0.14 to 0.5 mm ²)

4-2 Connecting the control power supply

■ **Pin assignment**

There are two terminals for 0V: One for control power supply and the other is for internal connection. Check each position in the figure and the table shown.

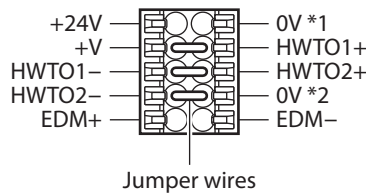

Sign	Description
+24V, 0V *1	Connects the control power supply.
HWTO1+, HWTO1- HWTO2+, HWTO2-	Connects the external device. When using the power removal function, remove the jumper wires and connect the external device. If the power removal function is not used, connect jumper wires between the terminals to short-circuit as shown in the figure.
EDM+, EDM-	Connects the external device. If the power removal function is not used, do not connect anything.
+V, 0V *2	These are for internal connection. Do not connect anything. If the power removal function is not used, connect a jumper wire between the terminals to short-circuit as shown in the figure.

■ **Wiring method of CN1 connector**

- Applicable lead wire: AWG26 to 20 (0.14 to 0.5 mm²)
 - Stripping length of wire insulation: 7 mm (0.28 in.)
1. Strip the insulation of the lead wire.
 2. Insert the lead wire while pushing the button of the orange color with a slotted screwdriver.
 3. After having inserted, release the button to secure the lead wire.

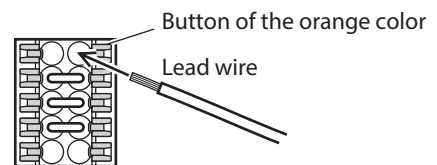

■ Power supply current capacity

Input power supply voltage	Power supply current capacity	
	Without electromagnetic brake	With electromagnetic brake
24 VDC±5 % *1	0.15 A	0.4 A *2

*1 When an electromagnetic brake motor is used, if the wiring distance between the cable type motor and the driver is extended to 20 m (65.6 ft.) using our cable, the input voltage is 24 VDC±4 %.

*2 The **AZM46** type is 0.23 A.

4-3 Connecting the main power supply and grounding

■ Pin assignment

Sign	Description
+	Main power supply input (24 VDC/48 VDC)
-	Main power supply GND
⏏	Frame Ground
MB1	Electromagnetic brake- (black)
MB2	Electromagnetic brake+ (white)
NC	Not connected

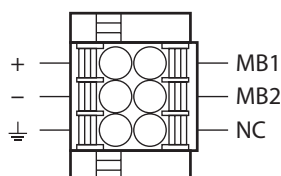

■ Wiring method of CN4 connector

- Applicable lead wire: AWG24 to 16 (0.2 to 1.25 mm²)
- Stripping length of wire insulation: 10 mm (0.39 in.)

1. Strip the insulation of the lead wire.
2. Insert the lead wire while pushing the button of the orange color with a slotted screwdriver.
3. After having inserted, release the button to secure the lead wire.

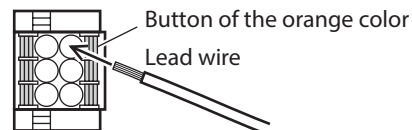

3 DC power input type

■ Power supply current capacity

The current capacity of the power supply varies depending on the product combined.

Check the current capacity in reference to the equipped motor model when using the **EAC Series**, **EAS Series**, or **EZS Series**.

The box (□) in the model indicates an alphabet (**B**, **M**, or **R**) representing the shape of the actuator.

Series	Model	Input power supply voltage	Power supply current capacity
AZ Series EAC Series EAS Series EZS Series	AZM14	24 VDC±5 %	0.4 A or more
	AZM15		0.5 A or more
	AZM24		1.6 A or more
	AZM26		1.5 A or more
	AZM46	24 VDC±5 % 48 VDC±5 %	1.5 A or more
	AZM48		2.1 A or more
	AZM66		3.3 A or more
	AZM69		3.1 A or more
DGII Series	DG□60	24 VDC±5 %	1.6 A or more
	DG□85	24 VDC±5 %	1.5 A or more
	DG□130	48 VDC±5 %	3.3 A or more
DR Series	DR20	24 VDC±5 %	0.4 A or more
	DR28		1.3 A or more
DRS2 Series	DRSM42	24 VDC±5 %	1.5 A or more
	DRSM60	48 VDC±5 %	2.2 A or more
EH Series	EH3	24 VDC±5 %	0.4 A or more
	EH4		1.6 A or more
L Series	LM2	24 VDC±5 %	3.3 A or more
	LM4	48 VDC±5 %	

■ Grounding the driver

Ground the Frame Ground Terminal (CN4) as necessary.

Do not share the grounding wire with a welder or any other power equipment.

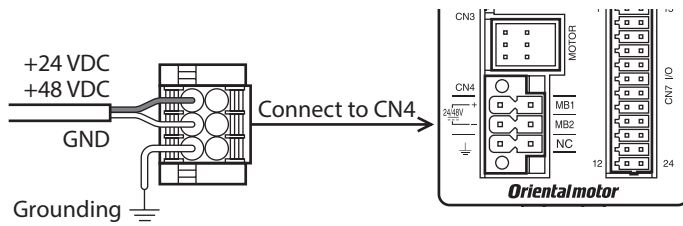

4-4 Connecting the EtherCAT communication cable

Connect the MainDevice and the CN5 connector (ECAT IN) on the driver using the EtherCAT communication cable. Be sure to connect from the CN6 connector (ECAT OUT) to the CN5 connector (ECAT IN) when linking drivers.

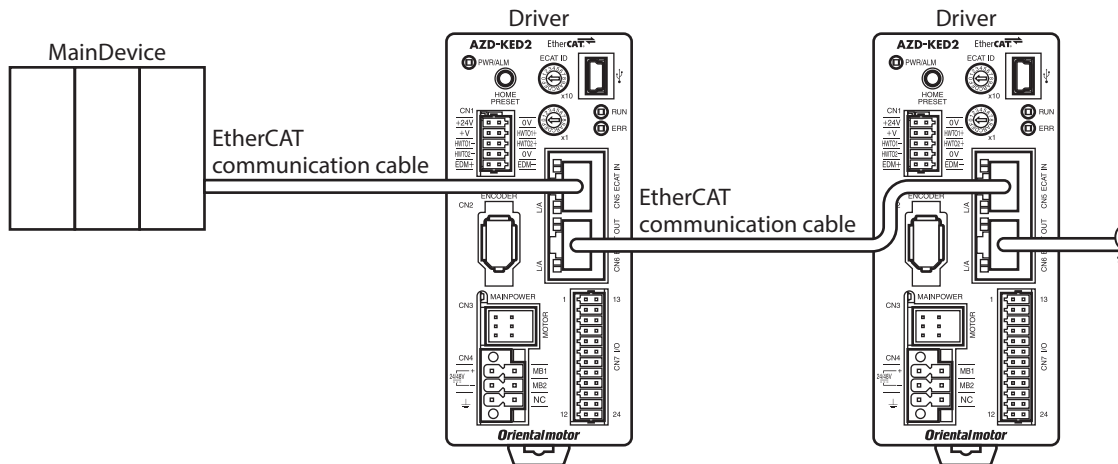

■ Pin assignment

Signal name	Description
TXP	Transmitted data+
TXN	Transmitted data-
RXP	Received data+
N.C.	—
N.C.	—
RXN	Received data-
N.C.	—
N.C.	—

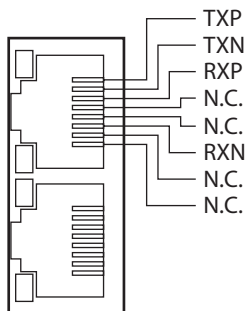

3 DC power input type

4-5 Connecting the USB cable

Using a USB cable of the following specification, connect a PC in which the **MEXE02** has been installed to the USB communication connector.

Specification	USB2.0 (full speed)
Cable	Length: 3 m (9.8 ft.) or less Shape: A to mini B



- Connect the driver and PC directly using the USB cable.
- In large electrically noisy environments, use the USB cable with a ferrite core or install a ferrite core to the USB cable.

4-6 Connecting the I/O signals

Connect when using direct I/O or sensors.

■ Pin assignment

Pin No.	Signal name *	Description *
1	CW+ [PLS+]	CW pulse input+ [Pulse input+]
2	CCW+ [DIR+]	CCW pulse input+ [Rotation direction switching input+]
3	IN0	Control input 0 (HOMES)
4	IN2	Control input 2 (ETO-CLR)
5	IN-COM 0-3	IN0 to IN3 inputs common
6	IN4	Control input 4 (FW-LS)
7	OUT0	Control output 0 (HOME-END)
8	OUT2	Control output 2 (PLS-RDY)
9	OUT4	Control output 4 (MOVE)
10	OUT-COM	Output common
11	ASG+	Phase A pulse output+
12	BSG+	Phase B pulse output+

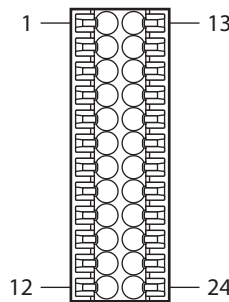

Pin No.	Signal name *	Description *
13	CW- [PLS-]	CW pulse input- [Pulse input-]
14	CCW- [DIR-]	CCW pulse input- [Rotation direction switching input-]
15	IN1	Control input 1 (FREE)
16	IN3	Control input 3 (EXT1)
17	IN-COM 4-5	IN4, IN5 inputs common
18	IN5	Control input 5 (RV-LS)
19	OUT1	Control output 1 (ETO-MON)
20	OUT3	Control output 3 (CRNT)
21	OUT5	Control output 5 (ALM-B)
22	GND	GND
23	ASG-	Phase A pulse output-
24	BSG-	Phase B pulse output-

* Values in brackets [] are signals when the 1-pulse input mode is set. Values in parentheses () are initial values.

■ Wiring method of CN7 connector

- Applicable lead wire: AWG26 to 20 (0.14 to 0.5 mm²)
 - Stripping length of wire insulation: 7 mm (0.28 in.)
1. Strip the insulation of the lead wire.
 2. Insert the lead wire while pushing the button of the orange color with a slotted screwdriver.
 3. After having inserted, release the button to secure the lead wire.

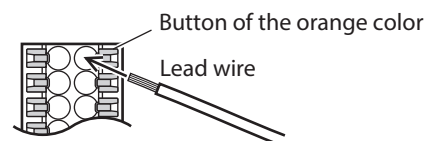

Be certain the I/O signal cable is as short as possible. The maximum input frequency will decrease as the cable length increases.

■ Connection example with a current sink output circuit

● When the pulse input circuit of the driver is of line driver type

The pin No.1, No.2, No.13, and No.14 are only available to the pulse input. Other functions cannot be assigned.

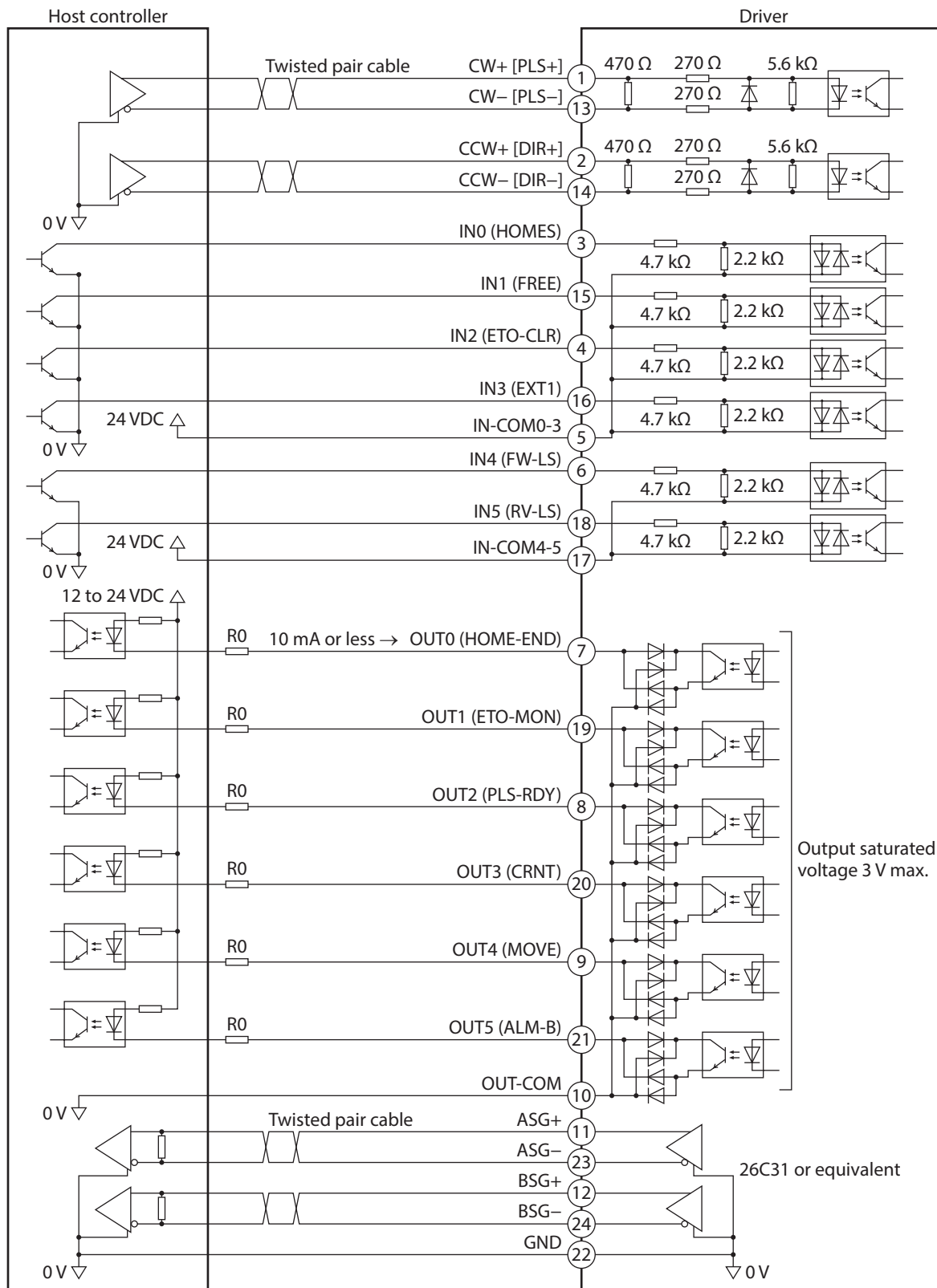

* Values in brackets [] are signals when the 1-pulse input mode is set.
 Values in parentheses () are initial values.

3 DC power input type

- Use input signals at 24 VDC.
- Use output signals at 12 to 24 VDC, 10 mA or less. If the current exceeds 10 mA, connect an external resistor R0 so that the current becomes 10 mA or less.
- The saturated voltage of the output signal is 3 V maximum.

● **When the pulse input circuit of the driver is of open collector type**

The pin No.1, No.2, No.13, and No.14 are only available to the pulse input. Other functions cannot be assigned.

- Use the CW [PLS] input and CCW [DIR] input at 5 to 24 VDC. When using signals at 24 VDC, connect an external resistor R1 (1.2 kΩ to 2.2 kΩ, 0.5 W or more). When using signals at 5 VDC, apply the voltage directly.

When the voltage of pulse input signals is 5 VDC

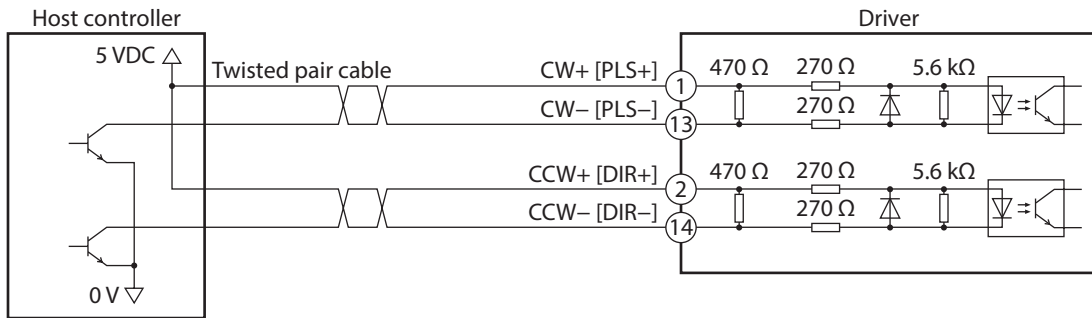

* Values in brackets [] are signals when the 1-pulse input mode is set.

When the voltage of pulse input signals is 24 VDC

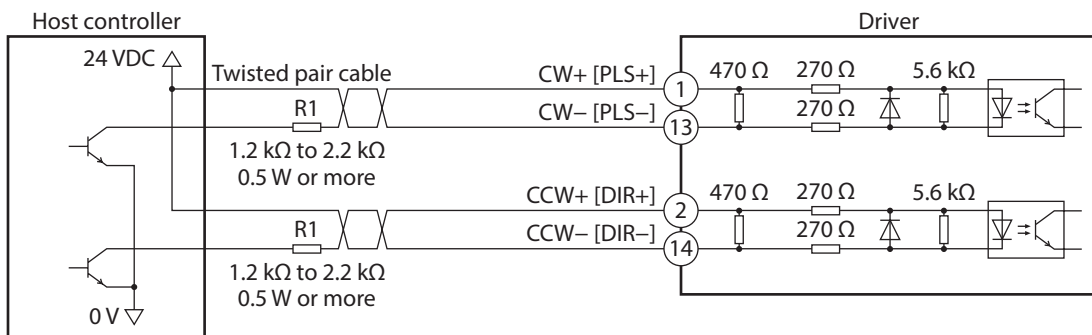

* Values in brackets [] are signals when the 1-pulse input mode is set.

■ Connection example with a current source output circuit

● When the pulse input circuit of the driver is of line driver type

The pin No.1, No.2, No.13, and No.14 are only available to the pulse input. Other functions cannot be assigned.

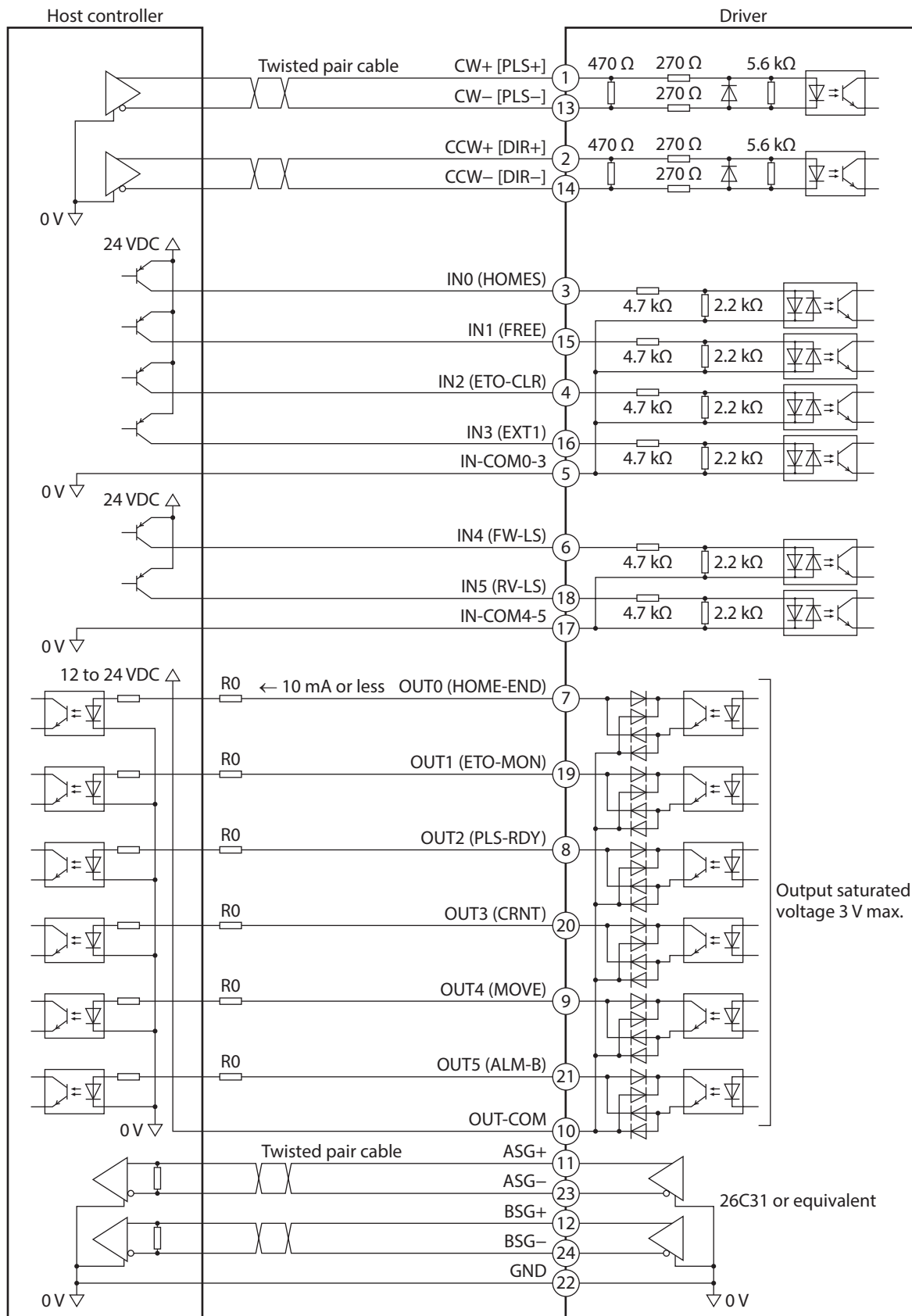

* Values in brackets [] are signals when the 1-pulse input mode is set. Values in parentheses () are initial values.



- Use input signals at 24 VDC.
- Use output signals at 12 to 24 VDC, 10 mA or less. If the current exceeds 10 mA, connect an external resistor R0 so that the current becomes 10 mA or less.
- The saturated voltage of the output signal is 3 V maximum.

● **When the pulse input circuit of the driver is of open collector type**

The pin No.1, No.2, No.13, and No.14 are only available to the pulse input. Other functions cannot be assigned.



Use the CW [PLS] input and CCW [DIR] input at 5 to 24 VDC. When using signals at 24 VDC, connect an external resistor R1 (1.2 kΩ to 2.2 kΩ, 0.5 W or more). When using signals at 5 VDC, apply the voltage directly.

When the voltage of pulse input signals is 5 VDC

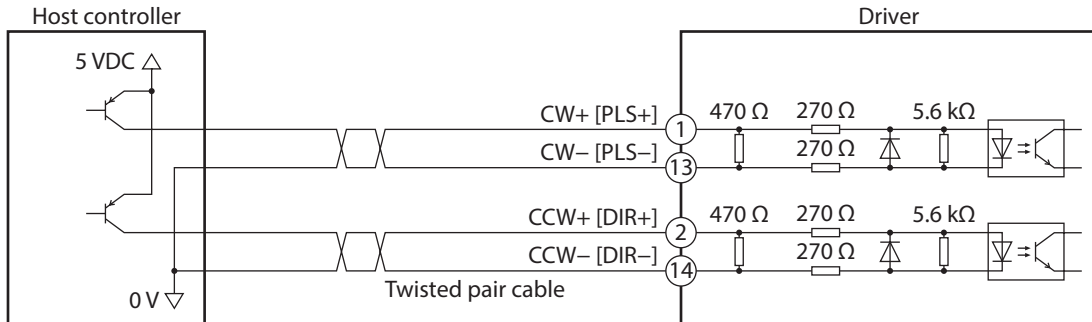

* Values in brackets [] are signals when the 1-pulse input mode is set.

When the voltage of pulse input signals is 24 VDC

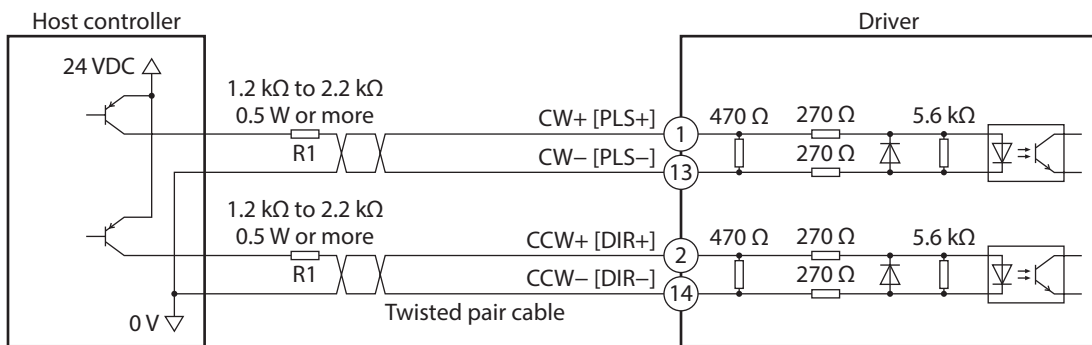

* Values in brackets [] are signals when the 1-pulse input mode is set.

4-7 Noise elimination measures

There are two types of electrical noises: One is a noise to invade into the driver from the outside and cause the driver malfunction, and the other is a noise to emit from the driver and cause peripheral equipment malfunction. For the noise that is invaded from the outside, take measures to prevent the driver malfunction. It is needed to take adequate measures because signal lines are very likely to be affected by the noise. For the noise that is emitted from the driver, take measures to suppress it.

■ Measures against electrical noise

There are the following three methods mainly to take measures against the electrical noise.

● Noise suppression

- When relays or electromagnetic switches are used, use noise filters or CR circuits to suppress surge generated by them.
- Use our connection cable when extending the wiring distance between the motor and the driver. Refer to p.90 for the model name. This is effective in suppressing the electrical noise emitted from the motor.
- Cover the driver by a metal plate such as aluminum. This is effective in shielding the electrical noise emitted from the driver.

● Prevention of noise propagation

- Connect a noise filter on the AC input side of the DC power supply.
- Place the power lines, such as the motor and the power supply cables, keeping a distance of 200 mm (7.87 in.) or more from the signal lines, and also do not bundle them or wire them in parallel. If a power cable and a signal cable have to cross, cross them at a right angle.
- Use shielded twisted pair cables for power lines and signal lines.
- Keep cables as short as possible without coiling and bundling extra lengths.
- Grounding multiple points will increase effect to block electrical noise because impedance on the grounding points is decreased. However, ground them so that a potential difference does not occur among the grounding points. I/O signal cable that includes a ground wire are provided in our product line. Refer to p.96 for the model name.
- To ground a shielded cable, use a metal cable clamp that can maintain contact with the entire circumference of the shielded cable, and ground as near the product as possible.

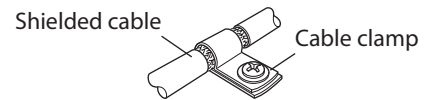

● Suppression of effect by noise propagation

- Loop the noise propagated cable around a ferrite core. Doing so will prevent the propagated noise invades into the driver or emits from the driver. The frequency band in which an effect by the ferrite core can be seen is generally 1 MHz or more. Check the frequency characteristics of the ferrite core used. When increasing the effect of noise attenuation by the ferrite core, loop the cable a lot.
- Change the transmission method of the pulse signal to the line driver type in order to prevent noise effects. If the pulse signal of the host controller is of the open collector type, use our pulse signal converter for noise immunity. Refer to p.97 for the model name.

■ Noise suppression product

● Noise filter

- Connect a noise filter (or equivalent) in the table on the AC input side of the DC power supply. When a power supply transformer is used, be sure to connect a noise filter on the AC input side of the power supply transformer. Doing so will prevent the propagated noise through the power line. Install the noise filter as close to the input terminals of DC power supply as possible.

Manufacturer	Part number
SOSHIN ELECTRIC CO., LTD.	HF2010A-UPF
Schaffner EMC	FN2070-10-06

- Use the AWG18 (0.75 mm²) or thicker wire for the input and output cables of the noise filter, and secure firmly using a cable clamp or others so that the cable does not come off the enclosure.
- Place the input cable as far apart as possible from the output cable, and do not wire the cables in parallel. If the input and output cables are placed at a close distance or if they are wired in parallel, the noise in the enclosure affects the power cable through stray capacitance, and the noise suppressing effect will reduce.
- Connect the ground terminal of the noise filter to the grounding point, using as thick and short a wire as possible.
- When connecting a noise filter inside an enclosure, wire the input cable of the noise filter as short as possible. Wiring in long distance may reduce the noise suppressing effect.

■ Our noise suppression products

Check the model names on p.96 and p.97.

● I/O signal cable

This is a shielded cable for good noise immunity to connect the driver and the host controller. The ground wire useful to grounding is extracted from both ends of the cable. The EMC testing is conducted using our I/O signal cable.

● Pulse signal converter for noise immunity

This product converts a pulse signal, which is output from the open collector output, to a pulse signal for good noise immunity by outputting the pulse signal again from the differential output.

● Surge suppressor

This product is effective to suppress the surge which occurs in a relay contact part. Connect it when using a relay or electromagnetic switch. CR circuit for surge suppression and CR circuit module are provided.

4-8 Conformity to the EMC Directive/Regulations

Effective measures must be taken against the EMI that the motor and the driver may give to adjacent control-system equipment, as well as the EMS of the motor and the driver itself, in order to prevent a serious functional impediment in the machinery. The use of the following installation and wiring methods will enable the motor and the driver to be compliant with the EMC Directive/Regulations.

Oriental Motor conducts EMC testing on its motors and drivers in accordance with "Example of installation and wiring" on p.77.

The user is responsible for ensuring the machine's compliance with the EMC, based on the installation and wiring explained next.

CAUTION

This equipment is not intended for use in residential environments nor for use on a low-voltage public network supplied in residential premises, and it may not provide adequate protection to radio reception interference in such environments.

● Connecting the noise filter

In large electrically noisy environments, connect a noise filter. Refer to "Noise filter" on p.75 for details.

● Connecting the power supply

Use a DC power supply compliant with the EMC Directive/Regulations.

Wire and ground the power supply over the shortest possible distance using a shielded cable. Refer to "Prevention of noise propagation" on p.75 for how to ground the shielded cable.

● Connecting the motor cable

Use our connection cable when extending the wiring distance between the motor and the driver. Refer to p.90 for the model name.

● Connecting the signal cable

Refer to "Prevention of noise propagation" on p.75.

● Grounding method

- The cable used to ground the motor, the driver, and the noise filter must be as thick and short as possible so that no potential difference is generated.
- Choose a large, thick and uniformly conductive surface for the grounding point.
- Refer to the p.68 for how to ground the driver.

● **Example of installation and wiring**

Use connection cables of Oriental Motor to connect the motor. Check the cable models on p.90.
 The figure shows an example when the cable type electromagnetic brake motor is used.
 The line driver system is used to drive the pulse signals.

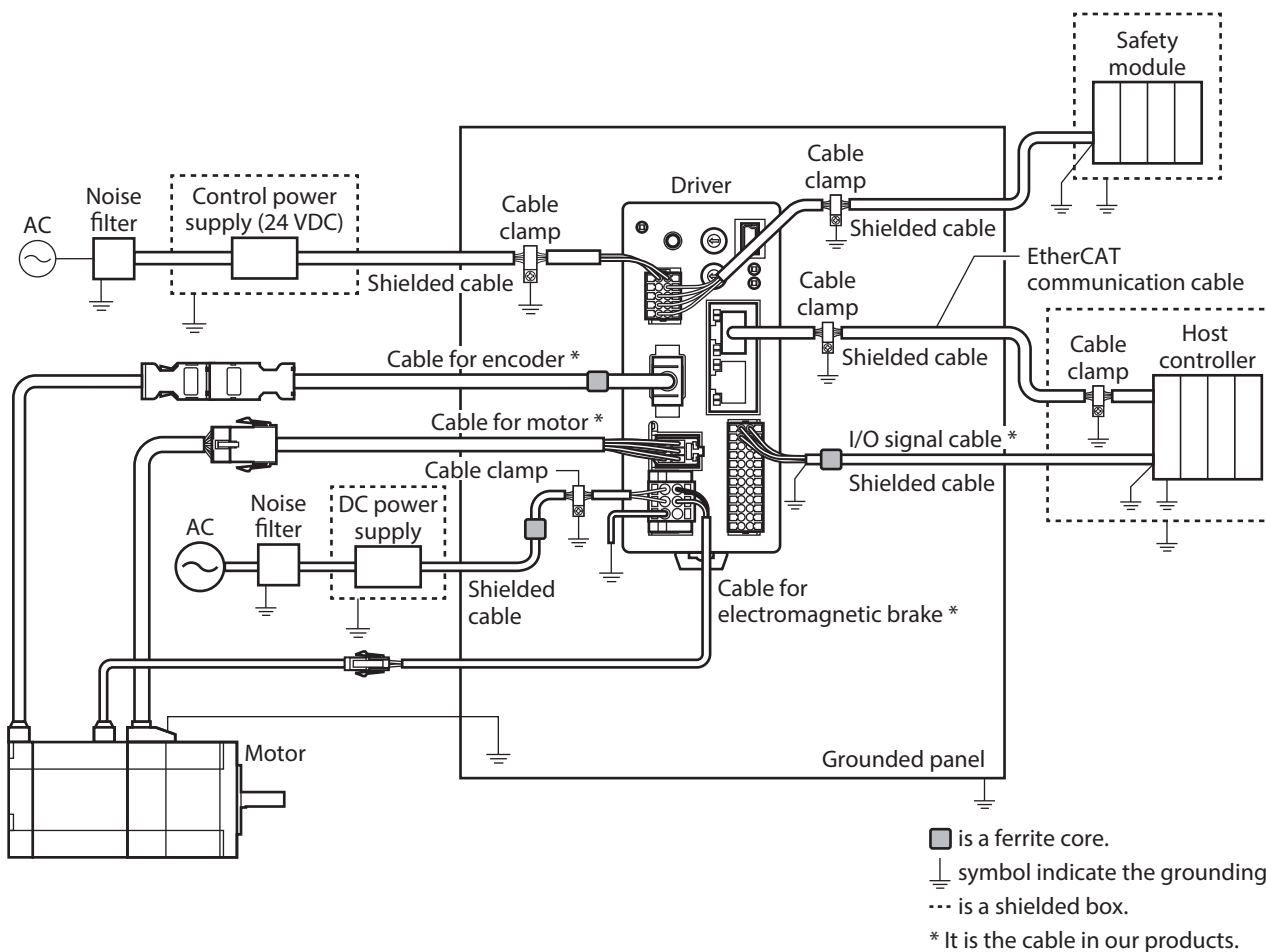

Note The driver uses parts that are sensitive to electrostatic charge. Take measures against static electricity since static electricity may cause the driver to malfunction or suffer damage.

5 Setting of node address

This chapter explains how to set the node address.

5-1 Setting method

Set the node address using two node address setting switches (ECAT ID ×10, ×1).

The node address setting switches are hexadecimal number. Convert the node address from decimal to hexadecimal to set.

When connecting two or more EtherCAT communication compatible products, do not set duplicate node address.

Factory setting: 0 (×10: 0, ×1: 0)

Setting range	Description
0 (00h)	The setting of the MainDevice is enabled.
1 to 255 (1h to FFh)	The setting of the driver is enabled.



Be sure to turn off the control power supply of the driver before setting the switches. If the switches are set while the control power supply is in an on-state, the new setting will not be enabled.

6 Power removal function

The power removal function is a function that stops supplying the power to the motor by the hardware. This function shuts off the drive signal of the inverter circuit that controls the motor current with two input channels (HWTO1 input, HWTO 2 input). This brings a shutoff state of the power supplying to the motor (power removal status). The power removal function is assumed to be used to prevent unexpected starting of the moving parts of equipment when an operator works inside the operating range of the moving parts.

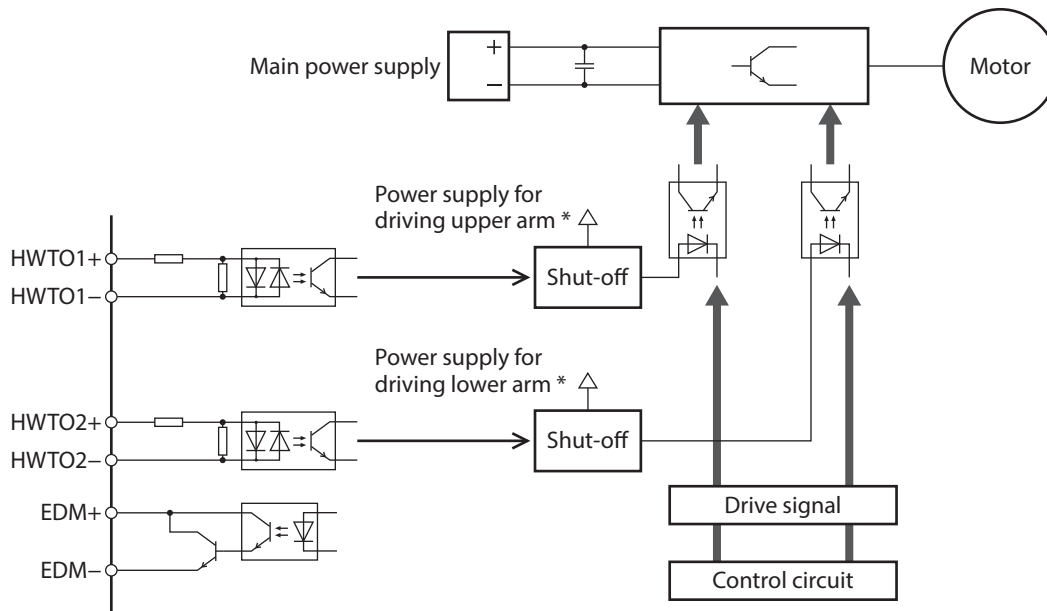

* Turning the HWTO1 input OFF causes the upper arm drive signal of the inverter circuit to shut off. Turning the HWTO2 input OFF causes the lower arm drive signal of the inverter circuit to shut off.



Note Be sure to check the motor is in a standstill state before executing the power removal function. If the power removal function is executed while the motor is operated, it may cause damage to the motor, driver, or equipment.

6-1 Safety parameters

Item	Specifications
Safety integrity level	SIL 3 *
Average frequency of a dangerous failure per hour	PFH=4.85×10 ⁻⁹ [1/h]
Hardware fault tolerance	HFT=1
Subsystem	Type A
Mission time	20 years
Response time	15 ms or less
Performance level	PL e (Category 3) *
Mean time to dangerous failure	MTTFd: High
Average diagnostic coverage	DC _{avg} : High
Stop category	0 (IEC 60204-1)

* It is necessary to monitor the EDM output using an external device.

6-2 Notes when using the power removal function

- When the power removal function is used, be sure to conduct a risk assessment of equipment in advance and check that the safety requirements of the safety-related parts of a control system are satisfied.
- The design of the safety-related parts of a control system using the power removal function should be performed by qualified personnel who are trained in the relevant safety standards and understand the contents of this chapter.
- If the power removal function operates, the motor output shaft may rotate due to external forces (such as gravity on a vertical axis). To hold the motor output shaft in position, install an external brake mechanism or equivalent. The brake mechanism of the electromagnetic brake motor is used for the purpose to hold the position. Do not use the brake mechanism of the electromagnetic brake motor for braking the motor rotation. This may result in injury or damage to equipment.
- If the power removal function operates, the driver stops supplying the power to the motor. However, the power supplying to the driver is not shut off, and the driver is not performed electrical insulation either. Before performing maintenance or inspection, always turn off the driver power, and check the MAIN POWER LED is turned off. Failure to do so may result in electric shock.
- If the inverter circuit is failed, the motor output shaft may rotate up to 180 degrees in an electrical angle (3.6 degrees in a mechanical angle) even when the power removal function operates. Make sure this movement does not cause hazardous situations. Failure to do so may result in injury or damage to equipment.
- Connect the I/O signals related to the power removal function to an external device that is certified under safety standards.
- Be sure to perform the verification testing of the power removal function when starting up or maintaining the equipment, or when replacing the driver. This may result in injury or damage to equipment. If the power removal function is used in an incorrect state such as incorrect wiring of I/O signals, the power removal function may not operate properly, causing hazardous situations.

6-3 I/O signals

■ HWTO1 input, HWTO2 input

The HWTO1 input and HWTO2 input are signals to operate the power removal function. Connect 24 VDC to the HWTO1+ and HWTO2+ terminals and 0 VDC to the HWTO1- and HWTO2- terminals.

Note Provide individual contacts for operating the HWTO1 input and the HWTO2 input.

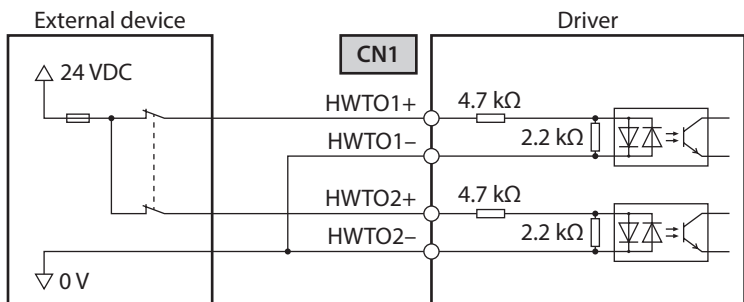

Specification

- Input voltage: 24 VDC±10 %

Safety input-off shot pulse for self-diagnosis

If the safety output signal output from an external device includes the safety input-off shot pulse for self-diagnosis, use an external device which pulse width is 1 ms or less. If the OFF-time of the HWTO1 input or the HWTO2 input by the safety input-off shot pulse is 1 ms or less, the power removal function does not operate.

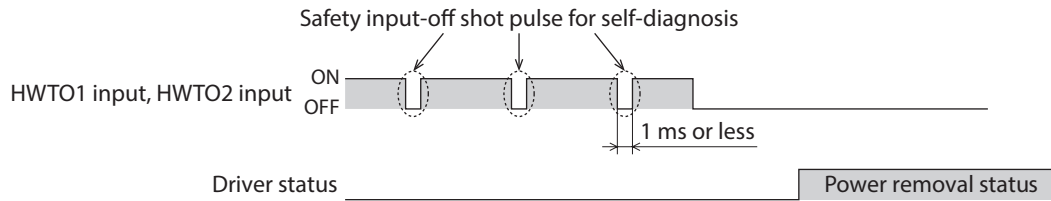

EDM output

The EDM output is a signal to monitor a failure in the power removal function.

Note The EDM output is not an output signal to ensure the safety. Do not use the EDM output for any other purpose except for monitoring a failure.

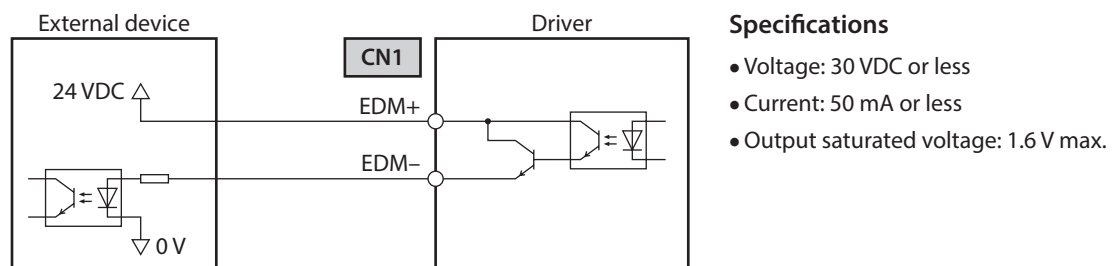

6-4 Operation of power removal function

Transition to power removal status

If both the HWTO1 and HWTO2 inputs are turned OFF, the driver transitions to the power removal status, and the power supplying to the motor is shut off by the hardware, causing the motor to put into a non-excitation state. In the power removal status, the status of the motor and driver will be as follows. [When the "HWTO mode selection (4190h)" is set to "0: Alarm is not present (initial value)"]

- The ETO-MON output is ON.
- The DCMD-RDY output, the READY output, the PLS-RDY output, and the MBC output are OFF.
- The PWR/ALM LED blinks in green.
- When an electromagnetic brake motor is used, the electromagnetic brake is in a state of holding the motor output shaft.

Note

- Be sure to check the motor is in a standstill state before executing the power removal function. If the power removal function is executed while the motor is operated, it may cause damage to the motor, driver, or equipment.
- It takes 15 ms maximum from when the HWTO1 and HWTO2 inputs are turned OFF until when the driver is in the power removal status.
- To transition to the power removal status, be sure to turn the HWTO1 and HWTO2 inputs OFF for at least 15 ms.
- The ETO-MON output, the DCMD-RDY output, the READY output, the PLS-RDY output, the MBC output, the PWR/ALM LED, and the electromagnetic brake are not safety-related parts of a control system.

● **Timing chart**

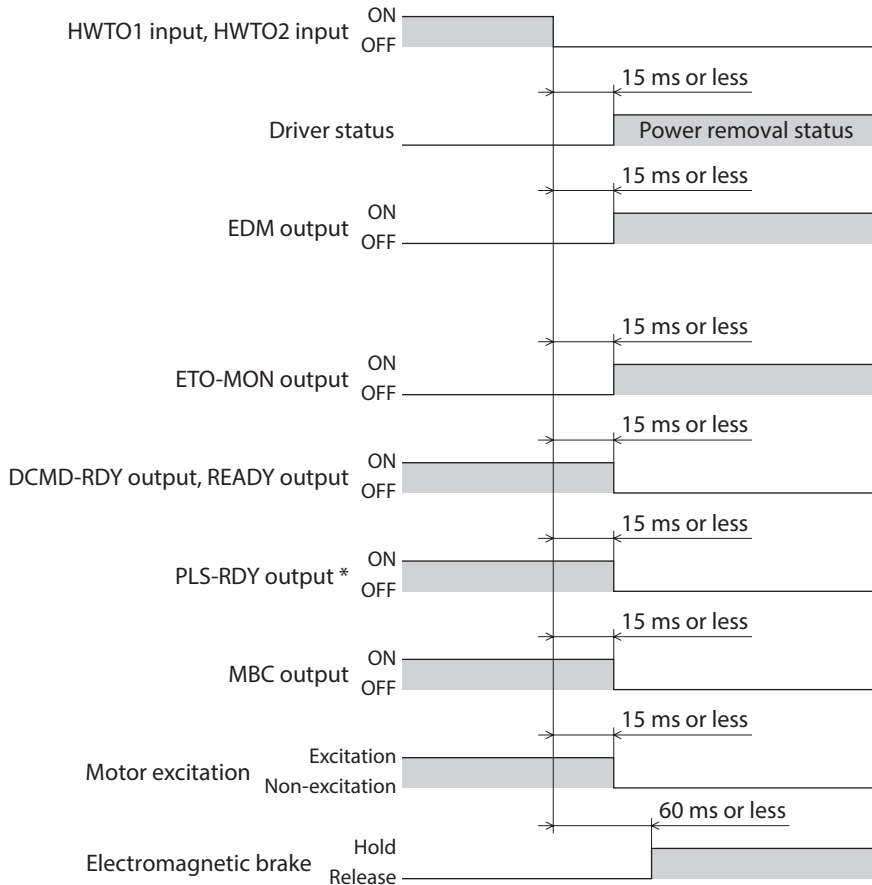

* When executing the operation by inputting pulses.

■ **Return from power removal status**

If both the HWT01 and the HWT02 inputs are turned ON, the power removal status is released. At this time, the motor remains in a non-excitation state. To excite the motor, turn the ETO-CLR input ON in a state where the excitation command is input from the MainDevice. (initial value: Activate at ON edge). When the ETO-CLR input is turned ON, the status of the motor and driver will be as follows.

- The ETO-MON output is OFF.
- The DCMD-RDY output, the READY output, the PLS-RDY output, and the MBC output are ON.
- The PWR/ALM LED is lit in green.
- When an electromagnetic brake motor is used, the electromagnetic brake is in a state of releasing the motor output shaft.

Note

- Check the equipment is in a safe state before returning the driver from the power removal status.
- Even if either the HWT01 input or the HWT02 input is turned ON, the power removal status cannot be released.
- If the ON-time of the HWT01 and HWT02 inputs is less than 15 ms, the power removal status may not be released.
- When the power removal status is released, a shut-off state of supplying the power to the motor by the hardware is also released.
- The ETO-CLR input is not safety-related part of a control system.

● Timing chart

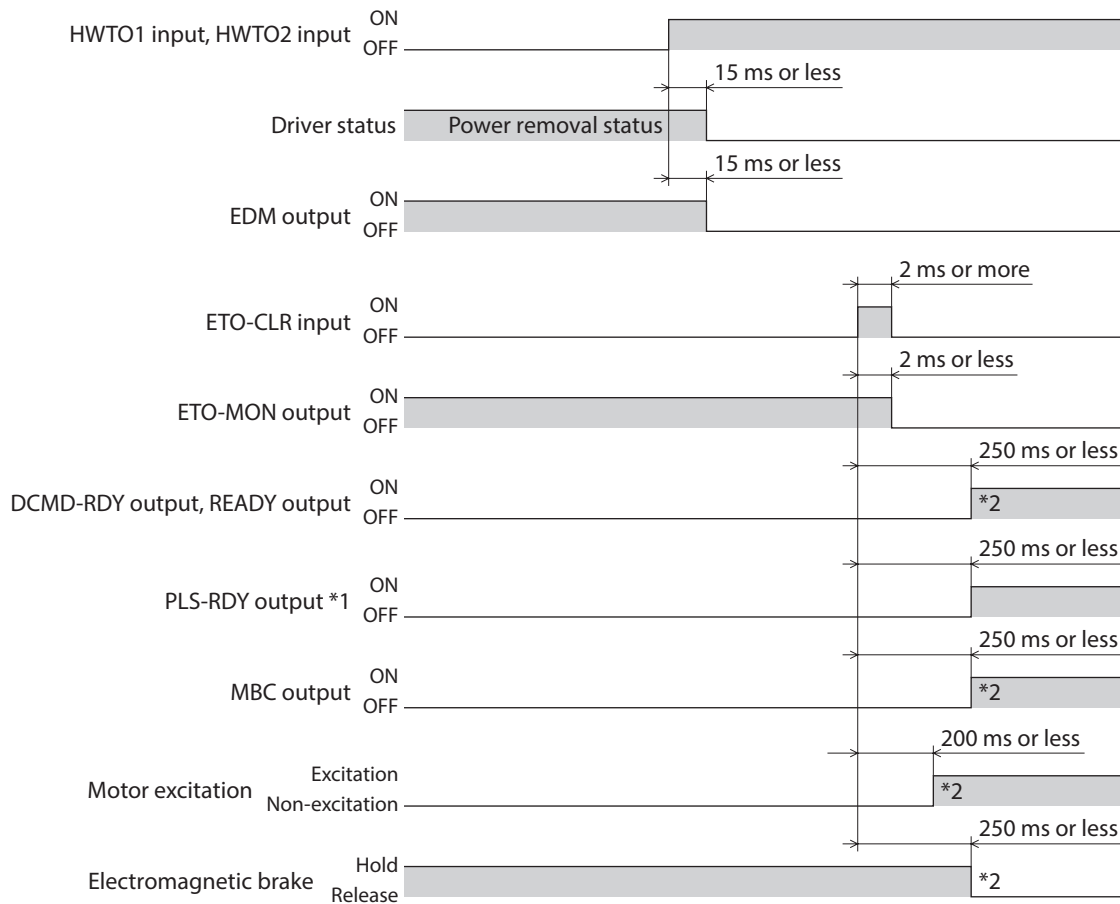

*1 When executing the operation by inputting pulses.

*2 It is the movement when the excitation command is input from the MainDevice while the ETO-CLR input is turned ON.

■ Detection for failure of the power removal function

Monitoring the input status of the HWT01 and HWT02 inputs and the output status of the EDM output relative to the inputs can detect the failure of the power removal function.

When the power removal function is properly operated, the combination of each signal is any of the following. Combinations other than the table indicate the power removal function of the driver is in a failure state.

HWT01 input	HWT02 input	EDM output
ON	ON	OFF
OFF	OFF	ON
ON	OFF	OFF
OFF	ON	OFF

If only one of the HWT01 input and the HWT02 input is ON or OFF, the external device or wiring has failed. Check the cause and take a measure immediately. At this time, the EDM output is in an OFF state and the motor puts into a non-excitation state.

Note

- Do not release the power removal function when the EDM output is in an OFF state.
- If the driver or external device is failed or an error in wirings occurs, check the cause and take a measure immediately.
- The power removal function of the driver is classified in Category 3 of ISO 13849-1. Not all dangerous failures can be detected with the EDM output.

6-5 Example of use

This section describes the connection method that the power removal function operates when the door (guard) is opened using a safety module.

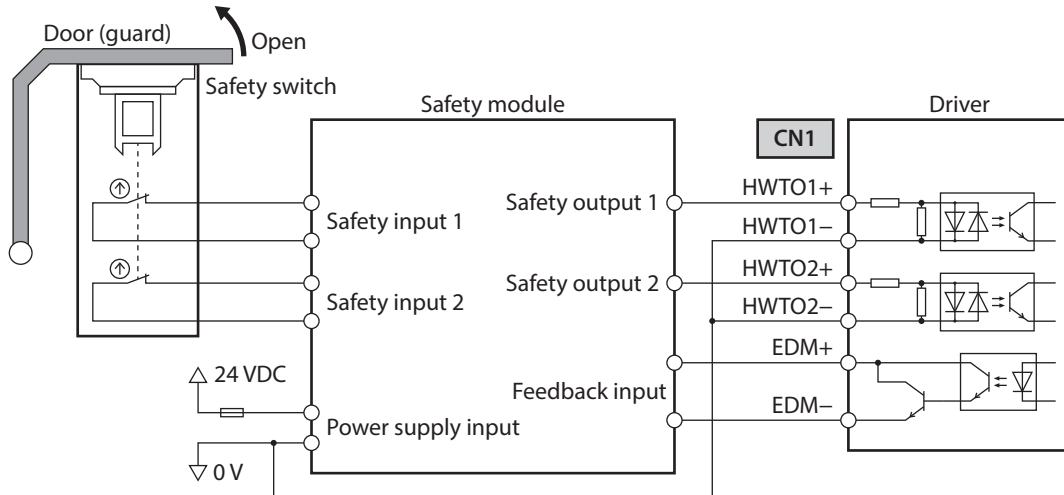

■ Operation in normal state

● When the door (guard) is opened

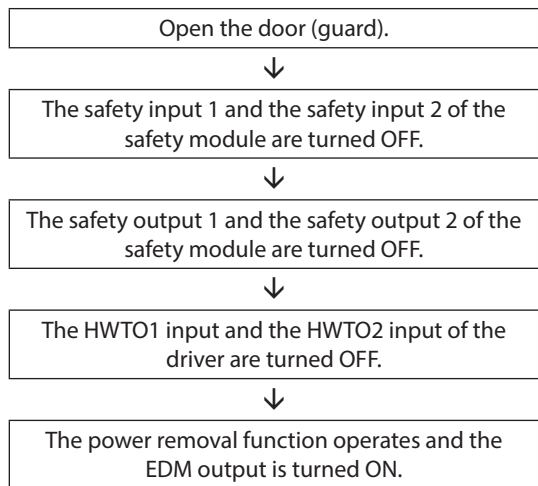

● When the door (guard) is closed

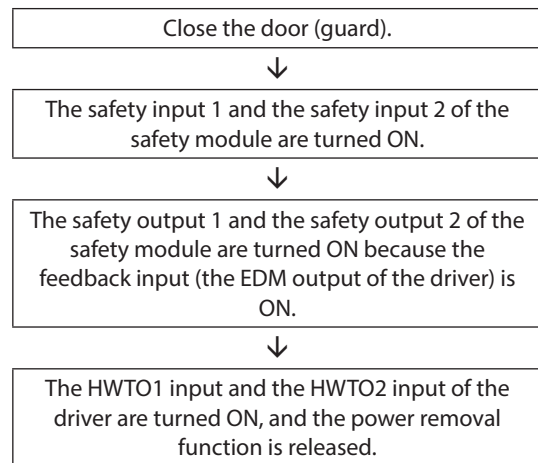

■ How to detect a failure

If a failure that the HWTO1 input or the HWTO2 input is not turned OFF occurs, the EDM output is not turned ON. A failure can be detected because the safety module is not reset even if the door (guard) is closed and the motor cannot be started.

6-6 Verification testing of power removal function

- Be sure to perform the verification testing of the power removal function when starting up or maintaining the equipment, or when replacing the driver.
- According to use conditions of the safety related parts of a control system, perform a verification testing of the power removal function at least once three months.
- Keep the verification result on record.

■ Description of verification testing

1. Turn on the control power supply and main power supply of the driver while both the HWTO1 and HWTO2 inputs are an ON state.
2. Use the MainDevice to input the excitation command.
3. Check that the motor is in an excitation state and the EDM output is in an OFF state.
4. Turn both the HWTO1 and HWTO2 inputs OFF.
5. Check that the motor goes into a non-excitation state and the EDM output is turned ON.

6-7 Related functions

Note The related functions are not safety-related parts of a control system.

● ETO-CLR input

If the ETO-CLR input is turned ON after both the HWTO1 and HWTO2 inputs are turned ON to release the power removal function, the motor puts into a state possible to excite.

Related object

Index	Name	Description	Initial value
4199h	ETO reset action (ETO-CLR)	Sets the judgment level of the signal when the motor is put into a state possible to excite by the ETO-CLR input. [Setting range] 1: Activate at ON edge 2: Activate at ON level	1

● HWTOIN-MON output

If the HWTO1 input or the HWTO2 input is turned OFF, the HWTOIN-MON output is turned ON.

● ETO-MON output

If the HWTO1 input or the HWTO2 input is turned OFF when the "HWTO mode selection (4190h)" is set to "0: Alarm is not present," the ETO-MON output is turned ON. If the motor is put into a state possible to excite by the ETO-CLR input after both the HWTO1 and HWTO2 inputs are turned ON, the ETO-MON output is turned OFF.

Related object

Index	Name	Description	Initial value
4190h	HWTO mode selection	Generates an alarm when the HWTO1 input or the HWTO2 input is turned OFF. [Setting range] 0: Alarm is not present 1: Alarm is present	0

● EDM-MON output

If both the HWTO1 and HWTO2 inputs are turned OFF, the EDM-MON output is turned ON.

Note Be sure to use the EDM output of CN1 to detect the failure of the power removal function.

● **Alarm of HWTO input detection**

If the "HWTO mode selection (4190h)" is set to "1: Alarm is present," an alarm will be generated when either the HWTO1 input or the HWTO2 input is turned OFF. (HWTO input detection, alarm code 68h)

At this time, the PWR/ALM LED blinks once in red repeatedly.

When the HWTO mode selection (4190h) is set to "1: Alarm is present," the motor will put into a state possible to excite if the ALM-RST input is turned from OFF to ON after the power removal function is released. (It is enabled at the ON edge.)

Related object

Index	Name	Description	Initial value
4190h	HWTO mode selection	Generates an alarm when the HWTO1 input or the HWTO2 input is turned OFF. [Setting range] 0: Alarm is not present 1: Alarm is present	0

● **Alarm of HWTO input circuit error**

If a time after either the HWTO1 input or the HWTO2 input is turned OFF until the other input is turned OFF exceeds the value set in the "HWTO delay time of checking dual system (4191h)," an alarm will be generated. (HWTO input circuit error, alarm code 53h)

At this time, the PWR/ALM LED blinks twice in red repeatedly.

Related object

Index	Name	Description	Initial value
4191h	HWTO delay time of checking dual system	If a time after either the HWTO1 input or the HWTO2 input is turned OFF until the other input is turned OFF exceeds the value set in this object, an alarm will be generated. [Setting range] 0 to 10 (disable), 11 to 100 ms	0

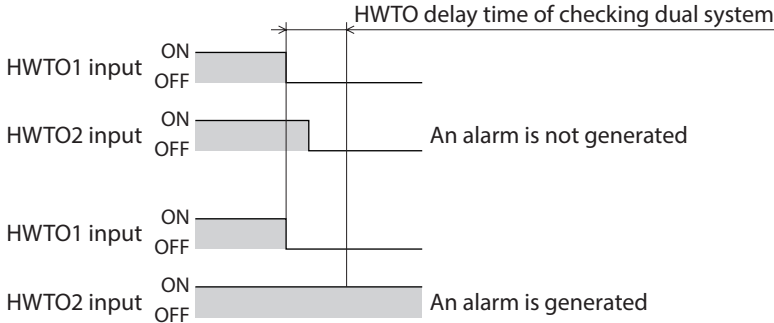

● **ETO reset ineffective period**

The motor will not put into a state possible to excite until the time set in the "ETO reset ineffective period (4198h)" is elapsed even if the ETO-CLR input is turned ON.

Related object

Index	Name	Description	Initial value
4198h	ETO reset ineffective period	Sets a time when the ETO-CLR input is disabled if the motor is put into a state possible to excite by the ETO-CLR input after the HWTO1 input and the HWTO2 input are turned ON. The motor will not put into a state possible to excite until the time set in this object is exceeded even if the ETO-CLR input is turned ON. [Setting range] 0 to 100 ms	0

When the ETO-CLR input is turned ON before the time set in the "ETO reset ineffective period (4198h)" is elapsed (when the motor is put into a state possible to excite at the ON edge of the input)

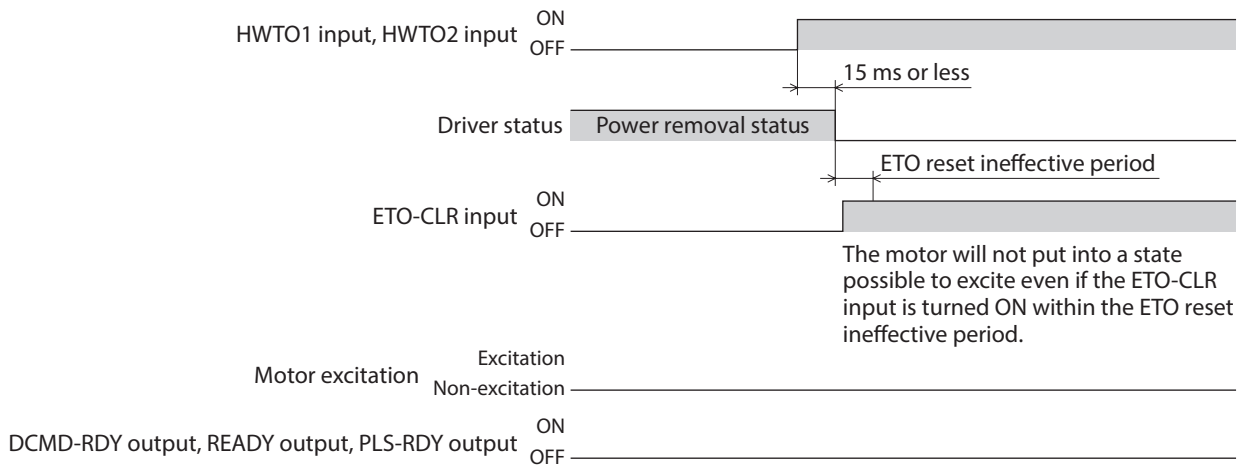

When the ETO-CLR input is turned ON after the time set in the "ETO reset ineffective period (4198h)" is elapsed (when the motor is put into a state possible to excite at the ON edge of the input)

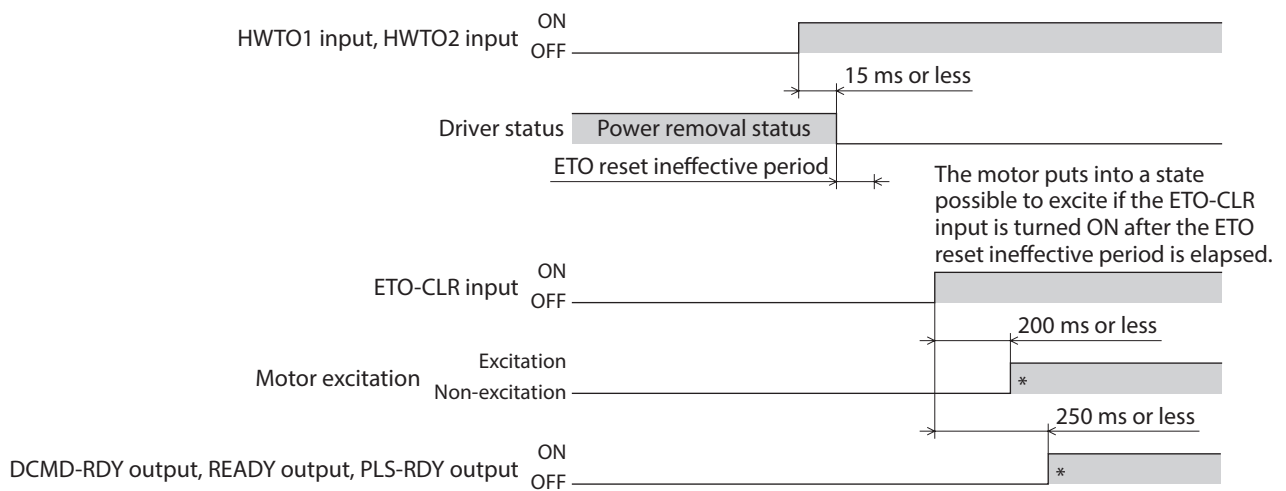

* It is the movement when the excitation command is input from the MainDevice at the time the ETO-CLR input is turned ON.

● **Signal judgment level of ETO-CLR input**

If the "ETO reset action (ETO-CLR) (4199h)" is set to "2: Activate at ON level," the motor will put into a state possible to excite at the ON level of the ETO-CLR input instead of the ON edge. (Initial value: Activate at ON edge)

Related object

Index	Name	Description	Initial value
4199h	ETO reset action (ETO-CLR)	Sets the judgment level of the signal when the motor is put into a state possible to excite by the ETO-CLR input. [Setting range] 1: Activate at ON edge 2: Activate at ON level	1

- **Motor excitation by input signals other than ETO-CLR input**

Changing the parameter can add a function to put the motor into a state possible to excite by the ALM-RST input and the STOP input. In the initial value, this function is set to the STOP input only.

Related object

Index	Name	Description	Initial value
419Ah	ETO reset action (ALM-RST)	The motor is put into a state possible to excite by the ALM-RST input after the HWTO1 input and the HWTO2 input are turned ON. [Setting range] 0: Disable 1: Activate at ON edge	0
419Ch	ETO reset action (STOP)	The motor is put into a state possible to excite by the STOP input after the HWTO1 input and the HWTO2 input are turned ON. [Setting range] 0: Disable 1: Activate at ON edge	1

7 Inspection and maintenance

7-1 Inspection

It is recommended that periodic inspections are conducted for the items listed below after each operation of the motor. If an abnormal condition is noted, discontinue any use and contact your nearest Oriental Motor sales office.

■ Inspection item

- Check if the openings in the driver are clogged.
- Check if the installation place of the driver is loose.
- Check if any of the connection parts of the driver is loose.
- Check if dust is deposited on the driver.
- Check if the driver has unusual smells or appearance defects.



The driver uses semiconductor components. Static electricity may damage the semiconductor components of the driver, so be extremely careful when handling the driver.

7-2 Warranty

Check on the Oriental Motor Website for the product warranty.

7-3 Disposal

Dispose the product correctly in accordance with laws and regulations, or instructions of local governments.

8 Cables

8-1 Connection cable (For cable type)

■ Connection cable set/Flexible connection cable set (For AZM14, AZM15, AZM24, AZM26)

These cables are used when connecting a motor and a driver.

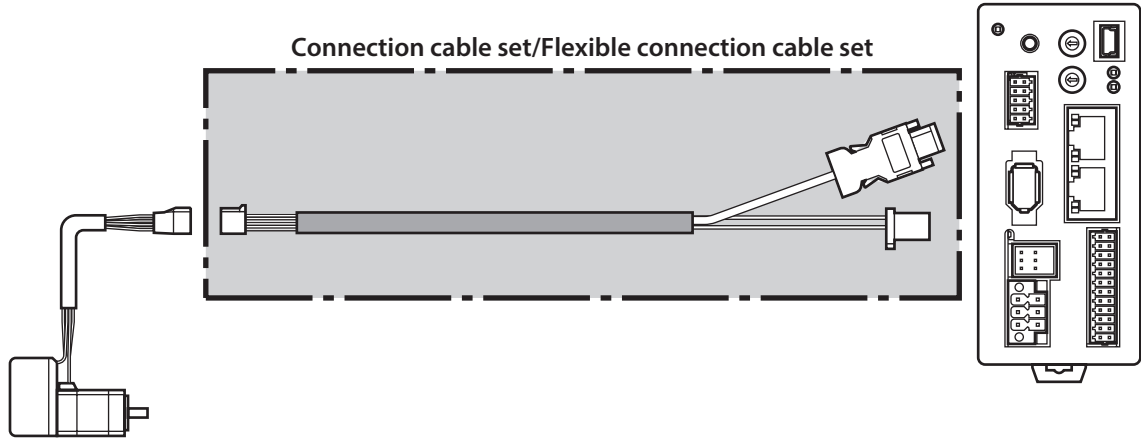

memo When installing the motor on a moving part, use a flexible cable.

● Connection cable set

For motor/encoder

Model	Length [m (ft.)]
CC005VZ2F2	0.5 (1.6)
CC010VZ2F2	1 (3.3)
CC015VZ2F2	1.5 (4.9)
CC020VZ2F2	2 (6.6)
CC025VZ2F2	2.5 (8.2)
CC030VZ2F2	3 (9.8)
CC040VZ2F2	4 (13.1)
CC050VZ2F2	5 (16.4)
CC070VZ2F2	7 (23.0)
CC100VZ2F2	10 (32.8)
CC150VZ2F2	15 (49.2)
CC200VZ2F2	20 (65.6)

● Flexible connection cable set

For motor/encoder

Model	Length [m (ft.)]
CC005VZ2R2	0.5 (1.6)
CC010VZ2R2	1 (3.3)
CC015VZ2R2	1.5 (4.9)
CC020VZ2R2	2 (6.6)
CC025VZ2R2	2.5 (8.2)
CC030VZ2R2	3 (9.8)
CC040VZ2R2	4 (13.1)
CC050VZ2R2	5 (16.4)
CC070VZ2R2	7 (23.0)
CC100VZ2R2	10 (32.8)
CC150VZ2R2	15 (49.2)
CC200VZ2R2	20 (65.6)

■ Connection cable set/Flexible connection cable set (For AZM46, AZM48, AZM66, AZM69)

These cables are used when connecting a motor and a driver. It is a set of two cables for the motor and the encoder. For the cable set of electromagnetic brake motors, a set of three cables for the motor, the encoder, and the electromagnetic brake is provided.

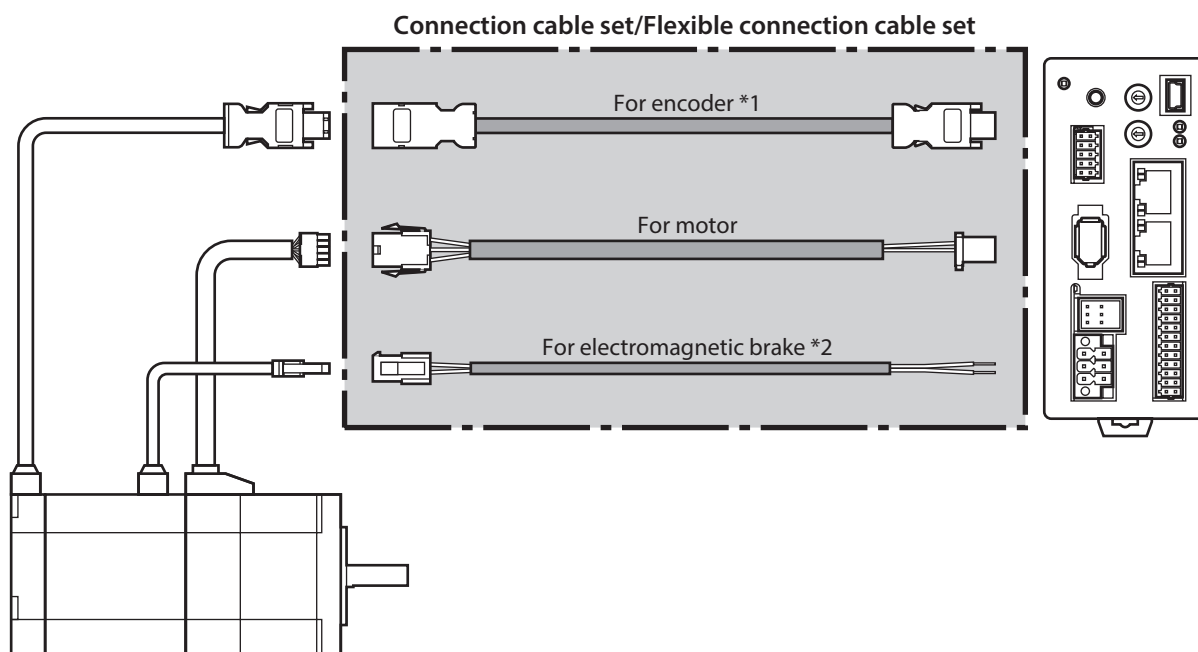

*1 Use the cable for encoder when the length of the encoder cable of motor is not enough.

*2 Only when the motor is the electromagnetic brake type.



When installing the motor on a moving part, use a flexible cable.

● Connection cable set

For motor/encoder

Model	Length [m (ft.)]
CC005VZF2	0.5 (1.6)
CC010VZF2	1 (3.3)
CC015VZF2	1.5 (4.9)
CC020VZF2	2 (6.6)
CC025VZF2	2.5 (8.2)
CC030VZF2	3 (9.8)
CC040VZF2	4 (13.1)
CC050VZF2	5 (16.4)
CC070VZF2	7 (23.0)
CC100VZF2	10 (32.8)
CC150VZF2	15 (49.2)
CC200VZF2	20 (65.6)

For motor/encoder/electromagnetic brake

Model	Length [m (ft.)]
CC005VZFB2	0.5 (1.6)
CC010VZFB2	1 (3.3)
CC015VZFB2	1.5 (4.9)
CC020VZFB2	2 (6.6)
CC025VZFB2	2.5 (8.2)
CC030VZFB2	3 (9.8)
CC040VZFB2	4 (13.1)
CC050VZFB2	5 (16.4)
CC070VZFB2	7 (23.0)
CC100VZFB2	10 (32.8)
CC150VZFB2	15 (49.2)
CC200VZFB2	20 (65.6)

● Flexible connection cable set

For motor/encoder

Model	Length [m (ft.)]
CC005VZR2	0.5 (1.6)
CC010VZR2	1 (3.3)
CC015VZR2	1.5 (4.9)
CC020VZR2	2 (6.6)
CC025VZR2	2.5 (8.2)
CC030VZR2	3 (9.8)
CC040VZR2	4 (13.1)
CC050VZR2	5 (16.4)
CC070VZR2	7 (23.0)
CC100VZR2	10 (32.8)
CC150VZR2	15 (49.2)
CC200VZR2	20 (65.6)

For motor/encoder/electromagnetic brake

Model	Length [m (ft.)]
CC005VZRB2	0.5 (1.6)
CC010VZRB2	1 (3.3)
CC015VZRB2	1.5 (4.9)
CC020VZRB2	2 (6.6)
CC025VZRB2	2.5 (8.2)
CC030VZRB2	3 (9.8)
CC040VZRB2	4 (13.1)
CC050VZRB2	5 (16.4)
CC070VZRB2	7 (23.0)
CC100VZRB2	10 (32.8)
CC150VZRB2	15 (49.2)
CC200VZRB2	20 (65.6)

■ Extension cable set/Flexible extension cable set
(For AZM14, AZM15, AZM24, AZM26)

These cables are used when extending the connection cable.

Use if the length of the connection cable used is not enough when extending the distance between a motor and a driver.

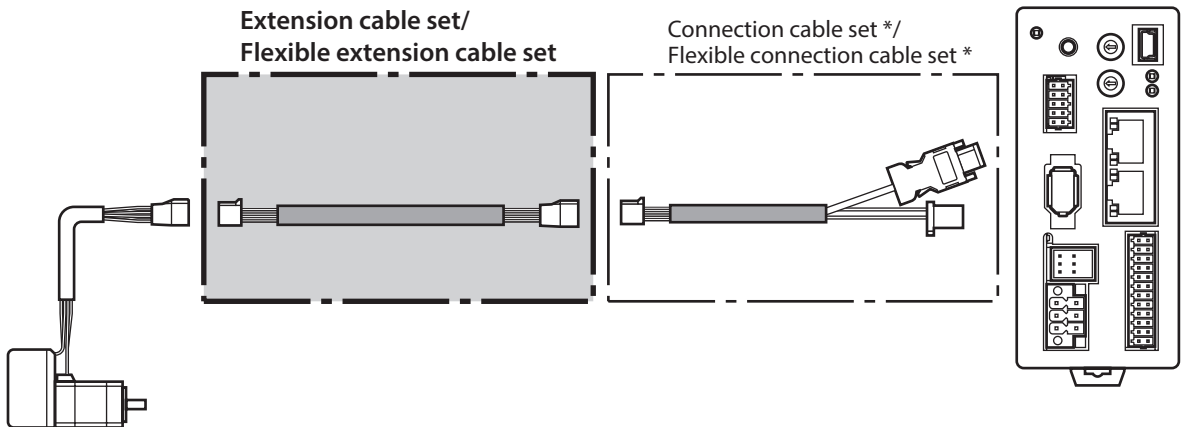

* Use the connection cable used.

- memo**
- When installing the motor on a moving part, use a flexible cable.
 - When extending the wiring length by connecting an extension cable to the connection cable, keep the total cable length to 20 m (65.6 ft.) or less.

● Connection cable set

For motor/encoder

Model	Length [m (ft.)]
CC010VZ2FT	1 (3.3)
CC020VZ2FT	2 (6.6)
CC030VZ2FT	3 (9.8)
CC050VZ2FT	5 (16.4)
CC070VZ2FT	7 (23.0)
CC100VZ2FT	10 (32.8)
CC150VZ2FT	15 (49.2)

● Flexible connection cable set

For motor/encoder

Model	Length [m (ft.)]
CC010VZ2RT	1 (3.3)
CC020VZ2RT	2 (6.6)
CC030VZ2RT	3 (9.8)
CC050VZ2RT	5 (16.4)
CC070VZ2RT	7 (23.0)
CC100VZ2RT	10 (32.8)
CC150VZ2RT	15 (49.2)

■ **Extension cable set/Flexible extension cable set**
(For AZM46, AZM48, AZM66, AZM69)

These cables are used when extending the connection cable.

Use if the length of the connection cable used is not enough when extending the distance between a motor and a driver.

It is a set of two cables for the motor and the encoder. For the cable set of electromagnetic brake motors, a set of three cables for the motor, the encoder, and the electromagnetic brake is provided.

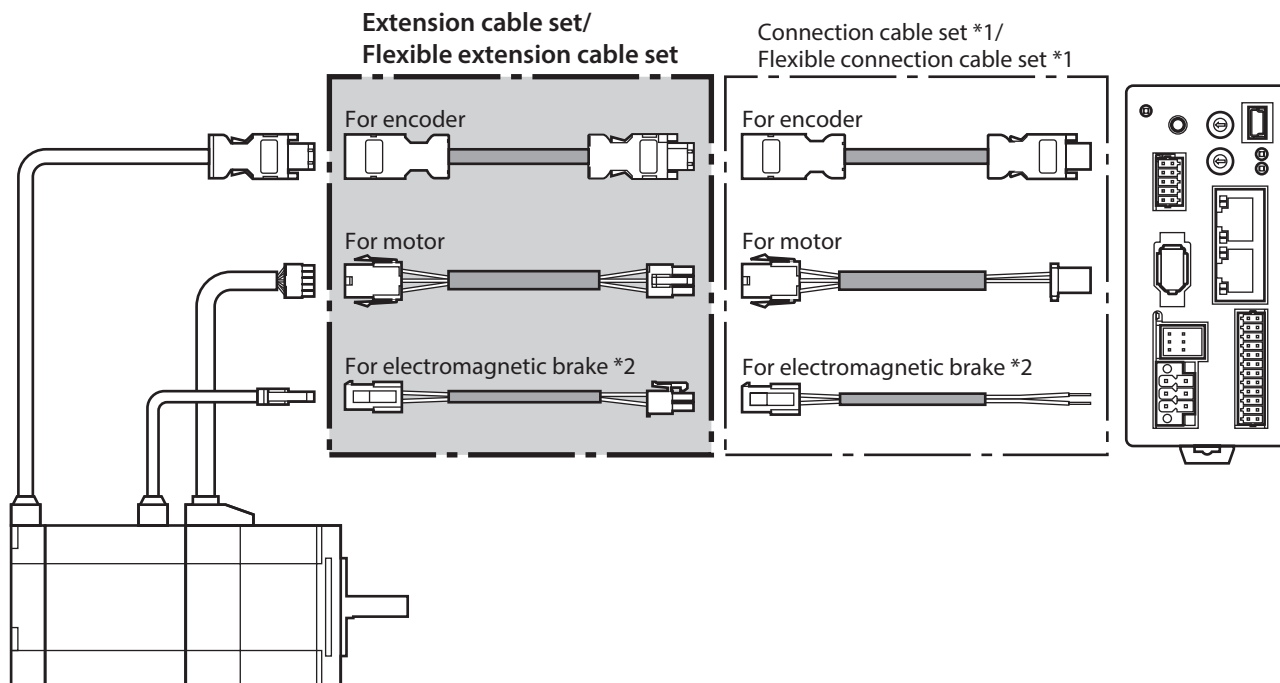

*1 Use the connection cable used.

*2 Only when the motor is the electromagnetic brake type.



- When installing the motor on a moving part, use a flexible cable.
- When extending the wiring length by connecting an extension cable to the connection cable, keep the total cable length to 20 m (65.6 ft.) or less.

● **Extension cable set**

For motor/encoder

Model	Length [m (ft.)]
CC010VZFT	1 (3.3)
CC020VZFT	2 (6.6)
CC030VZFT	3 (9.8)
CC050VZFT	5 (16.4)
CC070VZFT	7 (23.0)
CC100VZFT	10 (32.8)
CC150VZFT	15 (49.2)

For motor/encoder/electromagnetic brake

Model	Length [m (ft.)]
CC010VZFBT	1 (3.3)
CC020VZFBT	2 (6.6)
CC030VZFBT	3 (9.8)
CC050VZFBT	5 (16.4)
CC070VZFBT	7 (23.0)
CC100VZFBT	10 (32.8)
CC150VZFBT	15 (49.2)

● Flexible extension cable set

For motor/encoder

Model	Length [m (ft.)]
CC010VZRT	1 (3.3)
CC020VZRT	2 (6.6)
CC030VZRT	3 (9.8)
CC050VZRT	5 (16.4)
CC070VZRT	7 (23.0)
CC100VZRT	10 (32.8)
CC150VZRT	15 (49.2)

For motor/encoder/electromagnetic brake

Model	Length [m (ft.)]
CC010VZRB	1 (3.3)
CC020VZRB	2 (6.6)
CC030VZRB	3 (9.8)
CC050VZRB	5 (16.4)
CC070VZRB	7 (23.0)
CC100VZRB	10 (32.8)
CC150VZRB	15 (49.2)

8-2 Connection cables (For connector type)

■ Connection cable/Flexible connection cable

These cables are used when connecting a motor and a driver.

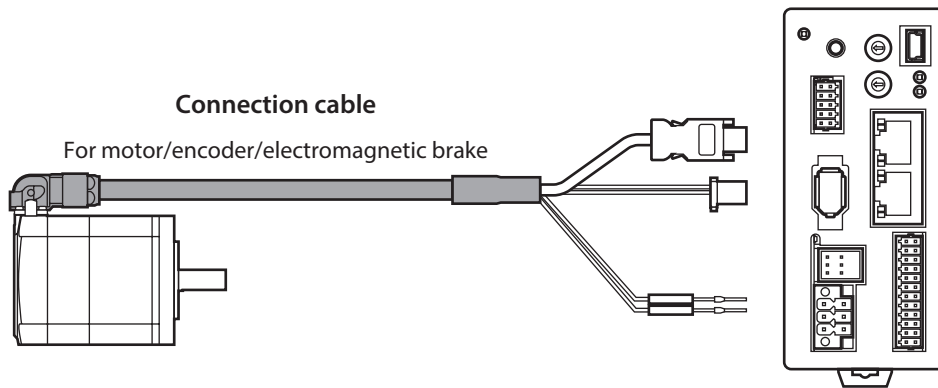

The model name of the connection cable varies depending on the outlet direction from the motor. Refer to the figures.

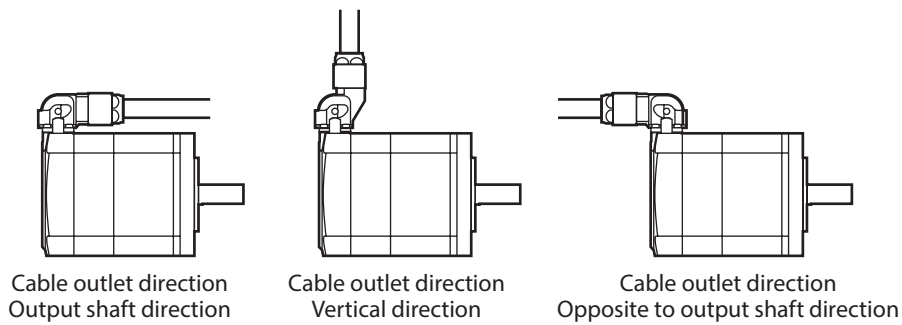

memo When installing the motor on a moving part, use a flexible cable.

- **Connection cable**

For motor/encoder

Length [m (ft.)]	Cable outlet direction		
	Output shaft direction	Vertical direction	Opposite to output shaft direction
0.5 (1.6)	CCM005Z1CFF	CCM005Z1CVF	CCM005Z1CBF
1 (3.3)	CCM010Z1CFF	CCM010Z1CVF	CCM010Z1CBF
2 (6.6)	CCM020Z1CFF	CCM020Z1CVF	CCM020Z1CBF
3 (9.8)	CCM030Z1CFF	CCM030Z1CVF	CCM030Z1CBF
5 (16.4)	CCM050Z1CFF	CCM050Z1CVF	CCM050Z1CBF
7 (23.0)	CCM070Z1CFF	CCM070Z1CVF	CCM070Z1CBF
10 (32.8)	CCM100Z1CFF	CCM100Z1CVF	CCM100Z1CBF

For motor/encoder/electromagnetic brake

Length [m (ft.)]	Cable outlet direction		
	Output shaft direction	Vertical direction	Opposite to output shaft direction
0.5 (1.6)	CCM005Z1DFF	CCM005Z1DVF	CCM005Z1DBF
1 (3.3)	CCM010Z1DFF	CCM010Z1DVF	CCM010Z1DBF
2 (6.6)	CCM020Z1DFF	CCM020Z1DVF	CCM020Z1DBF
3 (9.8)	CCM030Z1DFF	CCM030Z1DVF	CCM030Z1DBF
5 (16.4)	CCM050Z1DFF	CCM050Z1DVF	CCM050Z1DBF
7 (23.0)	CCM070Z1DFF	CCM070Z1DVF	CCM070Z1DBF
10 (32.8)	CCM100Z1DFF	CCM100Z1DVF	CCM100Z1DBF

- **Flexible connection cable**

For motor/encoder

Length [m (ft.)]	Cable outlet direction		
	Output shaft direction	Vertical direction	Opposite to output shaft direction
0.5 (1.6)	CCM005Z1CFR	CCM005Z1CVR	CCM005Z1CBR
1 (3.3)	CCM010Z1CFR	CCM010Z1CVR	CCM010Z1CBR
2 (6.6)	CCM020Z1CFR	CCM020Z1CVR	CCM020Z1CBR
3 (9.8)	CCM030Z1CFR	CCM030Z1CVR	CCM030Z1CBR
5 (16.4)	CCM050Z1CFR	CCM050Z1CVR	CCM050Z1CBR
7 (23.0)	CCM070Z1CFR	CCM070Z1CVR	CCM070Z1CBR
10 (32.8)	CCM100Z1CFR	CCM100Z1CVR	CCM100Z1CBR

For motor/encoder/electromagnetic brake

Length [m (ft.)]	Cable outlet direction		
	Output shaft direction	Vertical direction	Opposite to output shaft direction
0.5 (1.6)	CCM005Z1DFR	CCM005Z1DVR	CCM005Z1DBR
1 (3.3)	CCM010Z1DFR	CCM010Z1DVR	CCM010Z1DBR
2 (6.6)	CCM020Z1DFR	CCM020Z1DVR	CCM020Z1DBR
3 (9.8)	CCM030Z1DFR	CCM030Z1DVR	CCM030Z1DBR
5 (16.4)	CCM050Z1DFR	CCM050Z1DVR	CCM050Z1DBR
7 (23.0)	CCM070Z1DFR	CCM070Z1DVR	CCM070Z1DBR
10 (32.8)	CCM100Z1DFR	CCM100Z1DVR	CCM100Z1DBR

8-3 I/O signal cable

This cable is a shielded cable for the driver control I/O that has good noise immunity. The ground wire useful to grounding is extracted from both ends of the cable.

Select the cable suitable for the number of I/O signals connected.

Model list

Cable length [m (ft.)]	Number of lead wires			
	6 pcs.	10 pcs.	12 pcs.	16 pcs.
0.5 (1.6)	CC06D005B-1	CC10D005B-1	CC12D005B-1	CC16D005B-1
1 (3.3)	CC06D010B-1	CC10D010B-1	CC12D010B-1	CC16D010B-1
1.5 (4.9)	CC06D015B-1	CC10D015B-1	CC12D015B-1	CC16D015B-1
2 (6.6)	CC06D020B-1	CC10D020B-1	CC12D020B-1	CC16D020B-1

9 Accessories

9-1 Pulse signal converter for noise immunity

This product converts a pulse signal, which is output from the open collector output, to a pulse signal for good noise immunity by outputting the pulse signal again from the differential output.

Model: **VCS06**

9-2 Relay contact protection circuit/module

- **CR circuit for surge suppression**

This product is effective to suppress the surge which occurs in a relay contact part. Use it to protect the contacts of the relay or switch.

Model: **EPCR1201-2**

- **CR circuit module**

This product is effective to suppress the surge which occurs in a relay contact part. Use it to protect the contacts of the relay or switch.

Four pieces of CR circuit for surge suppression are mounted on the compact circuit, and this product can be installed to the DIN rail. This product can make the wiring easily and securely since it also supports terminal block connection.

Model: **VCS02**

3 DC power input type

4 EtherCAT communication

This part explains how to control via EtherCAT communication.

◆ Table of contents

1	Guidance	101	4	Function	146
2	Communications specifications.....	104	4-1	Touch probe.....	146
2-1	EtherCAT communication interface.....	104	4-2	Resolution	150
2-2	CiA402 drive profile	104	4-3	Wrap function	151
2-3	EtherCAT state machine (ESM).....	105	4-4	Operating current and stop current	151
2-4	Process data object (PDO)	105	4-5	Maintenance commands	152
2-5	Service data object (SDO)	108	4-6	Assignment of I/O function.....	153
2-6	Synchronous mode of EtherCAT communication	109	5	Position coordinate management ...	164
2-7	Distributed clocks.....	109	5-1	Overview of position coordinate management.....	164
2-8	Emergency message	109	5-2	Position coordinate origin	168
3	Drive profile	110	5-3	Parameters related to ABZO sensor	169
3-1	Drive state machine	110	5-4	Mechanism settings parameter.....	170
3-2	Operation mode.....	113	5-5	Initial coordinate generation & wrap coordinate parameter	171
3-3	Cyclic synchronous position mode (CSP)	113	6	Save of parameters	177
3-4	Profile position mode (PP).....	115	7	Object dictionary.....	178
3-5	Cyclic synchronous velocity mode (CSV)	126	7-1	Composition of the object dictionary...	178
3-6	Profile velocity mode (PV)	129	7-2	Objects of the CoE communication area	179
3-7	Homing mode (HM)	132	7-3	Objects of the profile area	184
			7-4	Objects of the manufacturer-specific area	195

■ Setting of data and parameters

Data and parameters described in this "4 EtherCAT communication" can be set using the **MEXE02** in addition to EtherCAT communication.

■ Notation rules

● Timing to update

When a object is changed, the timing to update the new value varies depending on the object.
In this part, each update timing is represented in an alphabet.

Notation	Update timing	Description
A	Update immediately	Recalculation and setup are immediately executed when the parameter is written.
B	Update after operation stop	Recalculation and setup are executed when the operation is stopped.
C	Update after executing Configuration	Recalculation and setup are executed after Configuration is executed or executing write batch non-volatile memory and turning on the control power supply again.
D	Update after turning on the control power supply again	Recalculation and setup are executed after executing write batch non-volatile memory and turning on the control power supply again.

1 Guidance

If you are new to this product, read this chapter to understand the operating methods along with the operation flow. This is an example how to operate the motor via EtherCAT communication.

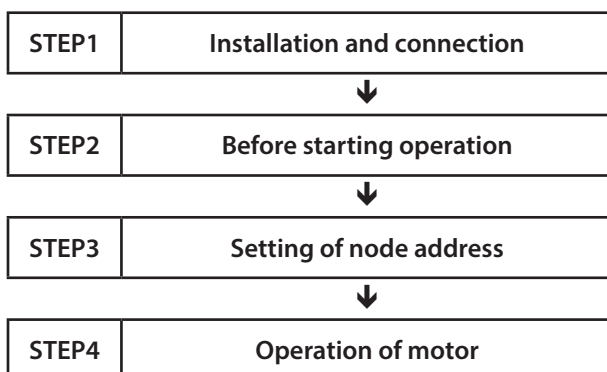

- **Operating conditions**

This operation is performed under the following conditions.

- | |
|---|
| <ul style="list-style-type: none">● Number of drivers connected: one unit● Node address: 1 |
|---|

Note

- Before operating the motor, check the condition of the surrounding area to ensure safety.
- Before starting based on the guidance, import the ESI file to the configuration tool of the MainDevice and register the system configuration in advance. For details, contact your nearest Oriental Motor sales office.

STEP 1 Check the installation and connection.

■ AC power input driver

The figure shows models for single-phase 200 to 240 VAC input.

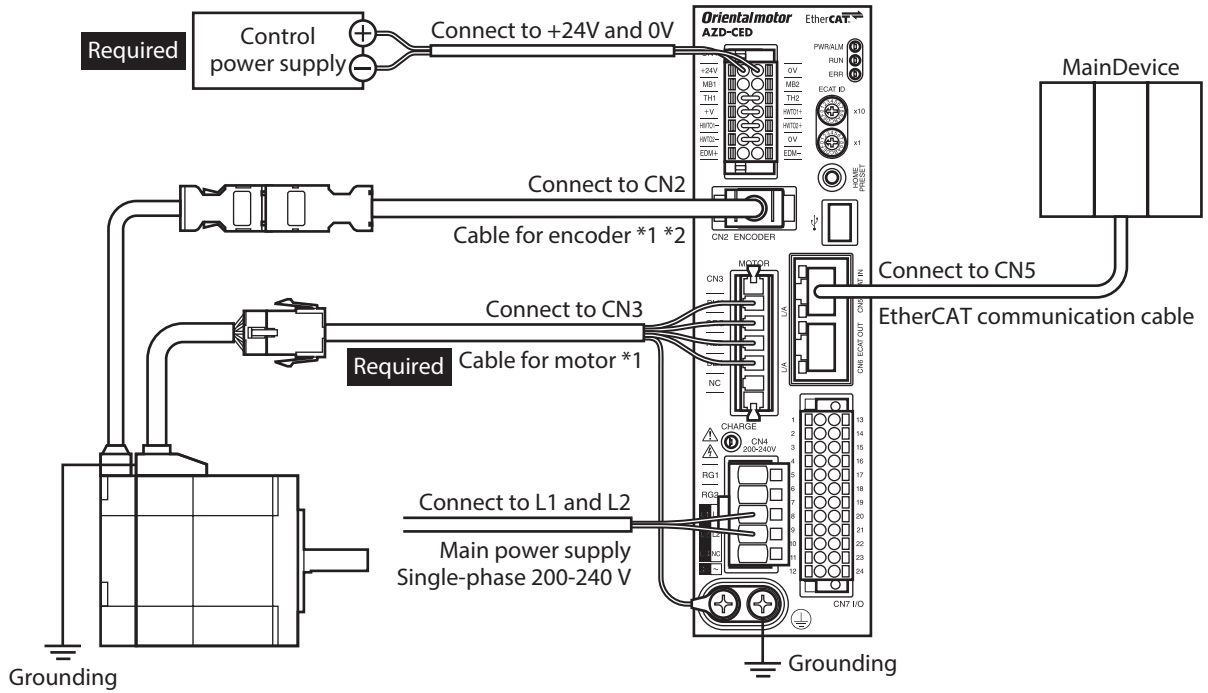

- *1 These cables are provided as our products. Purchase it separately.
- *2 Use the cable for encoder when the length of the encoder cable of motor is not enough.

■ DC power input driver

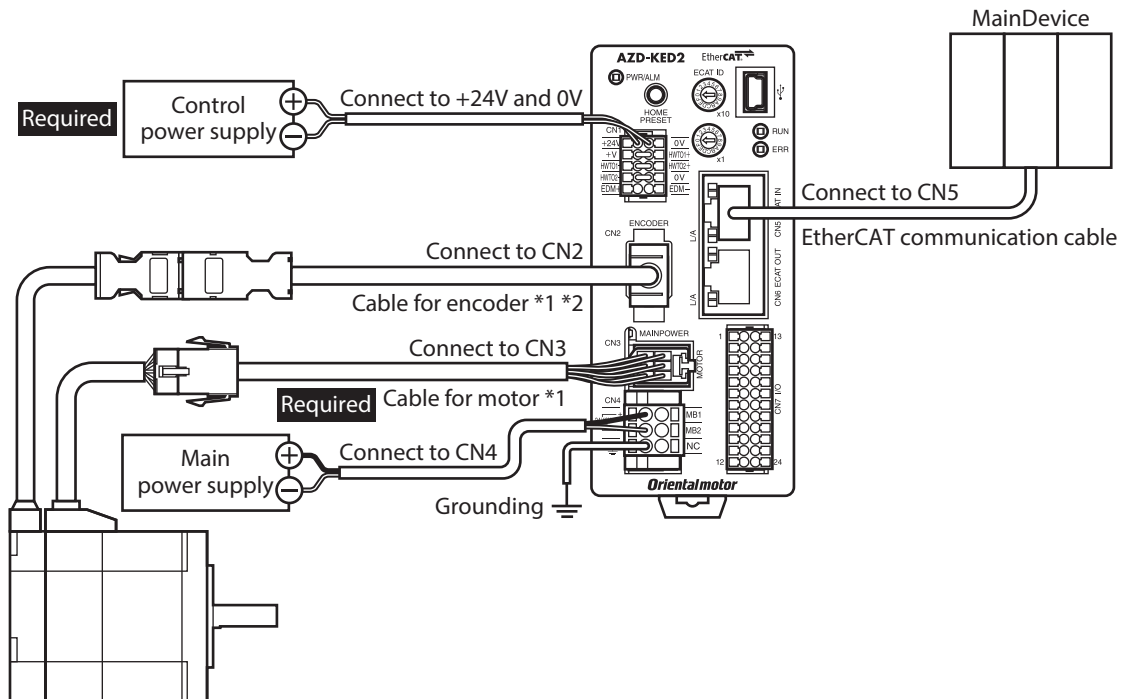

- *1 These cables are provided as our products. Purchase it separately.
- *2 Use the cable for encoder when the length of the encoder cable of motor is not enough.

STEP 2 Make preparations for operation.

Refer to “Before starting operation” in the **AZ Series OPERATING MANUAL Function Edition**.

STEP 3 Set an node address.

Set an node address using the node address setting switches (ECAT ID $\times 10$, $\times 1$) of the driver.

1. Set the node address setting switches as shown next.

Settings: 1 ($\times 10$: 0, $\times 1$: 1)

■ AC power input driver

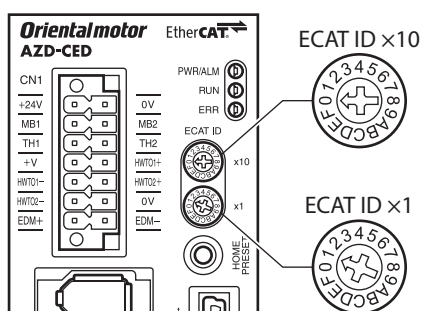

■ DC power input driver

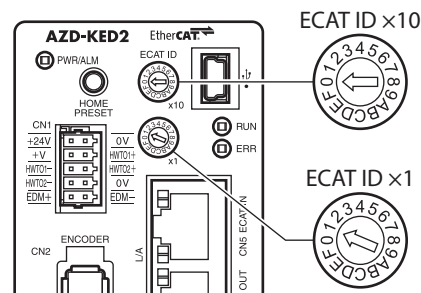

2. Turn on the control power supply again.



Be sure to turn off the control power supply of the driver before setting the switches. If the switches are set while the control power supply is in an on-state, the new setting will not be enabled.

STEP 4 Operate the motor.

Put the motor into an excitation state via EtherCAT communication to input the operation command.

STEP 5 Were you able to operate the motor properly?

How did it go? Were you able to operate the motor properly? If the motor does not operate, check the following points.

- Is the PWR/ALM LED blinking in red?
An alarm is being generated. Refer to p.218 for details.
- Are the power supply, the motor and the EtherCAT communication cable connected securely?
- Is the node address set correctly?
- Is the ERR LED blinking in red?
A communication error is being detected. Refer to p.22 (AC power input driver) or p.62 (DC power input driver) for details.

2 Communications specifications

2-1 EtherCAT communication interface

Item	Description
Communications standards	IEC 61158 Type12
Physical layer/Protocol	100 BASE-TX (IEEE 802.3)
Transmission rate	100 Mbps
Communication cycle	<ul style="list-style-type: none"> • Free run mode: 1 ms or more • Sync manager 2 event synchronization mode: 1 ms or more • DC mode: 0.25 ms, 0.5 ms, 1 ms, 2 ms, 3 ms, 4 ms, 5 ms, 6 ms, 7 ms, 8 ms
Communication port/Connector	RJ45x2 (shielded) ECAT IN: EtherCAT input ECAT OUT: EtherCAT output
Topology	Daisy chain (Up to 65,535 nodes)
Process data	Variable PDO mapping
Sync manager	<ul style="list-style-type: none"> • SM0: Mailbox output • SM1: Mailbox input • SM2: Process data output • SM3: Process data input
Mailbox (CoE)	<ul style="list-style-type: none"> • Emergency message • SDO request • SDO response • SDO information
Synchronization mode	<ul style="list-style-type: none"> • Free run mode (asynchronous) • Sync manager 2 event synchronization mode • DC mode (SYNC0 event synchronization)
Device profile	IEC 61800-7 CiA402 drive profile

2-2 CiA402 drive profile

Item	Description
Operation mode	<ul style="list-style-type: none"> • Profile position mode (PP) • Profile velocity mode (PV) • Homing mode (HM) • Cyclic synchronous position mode (CSP) • Cyclic synchronous velocity mode (CSV)
Function	<ul style="list-style-type: none"> • Touch probe (position latch) function 2 inputs (EXT1, EXT2)

2-3 EtherCAT state machine (ESM)

The EtherCAT state machine (ESM) is controlled by the MainDevice.

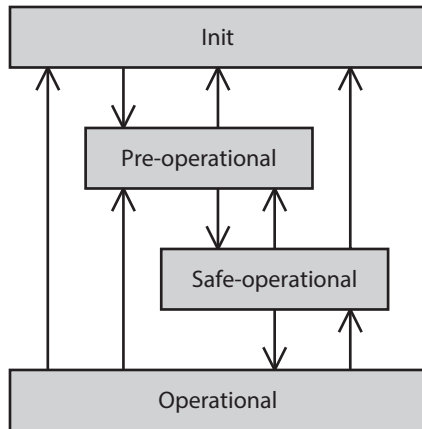

ESM state	SDO communication	Transmit PDO (TxPDO)	Receive PDO (RxPDO)	Status
Init	Not possible	Not possible	Not possible	During initialization. Communication is not possible.
Pre-operational	Possible	Not possible	Not possible	The mailbox communication (SDO) is possible. The process data communication (PDO) is not possible.
Safe-operational	Possible	Possible	Not possible	The mailbox communication and transmit PDO are possible. The status of the driver can be sent to the MainDevice by the transmit PDO.
Operational	Possible	Possible	Possible	The mailbox communication, transmit PDO, and receive PDO are possible. Commands can be sent from the MainDevice to the driver by the PDO communication.

2-4 Process data object (PDO)

The process data object (PDO) is used in real-time data communication of EtherCAT communication.

There are two types of PDO; transmit PDO (TxPDO) and receive PDO (RxPDO).

The transmit PDO (TxPDO) is to send data to the MainDevice from the driver. The receive PDO (RxPDO) is to receive data from the MainDevice to the driver.

Contents, which are sent and received using the PDO, are set by the PDO mapping object and the sync manager 2 and sync manager 3 PDO assignment objects.

The PDO mapping is to set the PDO mapping object.

Sync manager 2 PDO assignment and sync manager 3 PDO assignment are to set the PDO mapping object that performs communication actually.

The PDO mapping object is consisted of 4 bytes that are indexes of assigned object (Index), sub-index (Sub-index), and data length (Length). Only data of 08h (1 byte), 10h (2 bytes), and 20h (4 bytes) can be set in the data length.

Index	Sub-index	Data length
(2 bytes)	(1 byte)	(1 byte)

■ PDO mapping object

Up to 16 objects can be mapped in a single PDO.

Receive PDO mapping object		Transmit PDO mapping object	
Receive PDO	Index	Transmit PDO	Index
RxPDO1	1600h	TxPDO1	1A00h
RxPDO2	1601h	TxPDO2	1A01h

Objects to be mapped in the PDO are as follows.

Objects of profile area	Objects of manufacturer-specific area
6000h to 67FFh	4000h to 4FFFh



The configuration of objects is as follows.

Index (Hex)	Object	Overview
1000h to 1FFFh	CoE communication area	CoE communication area
2000h to 3FFFh	Manufacturer specific area	Not used
4000h to 4FFFh		Driver object
5000h to 5FFFh		Not used
6000h to 67FFh	Profile area	Profile area

■ Sync manager 2 and sync manager 3 PDO assignment objects

The SM (sync manager channel) PDO assignment objects set the relationship between the PDO and sync manager. The "Sync manager 2 PDO assignment (1C12h)" is the assignment object dedicated to the receive PDO. The "Sync manager 3 PDO assignment (1C13h)" is the assignment object dedicated to the transmit PDO. Objects of up to 64 bytes can be assigned.

■ Setting of PDO mapping object

The PDO mapping can be changed when the ESM is pre-operational. Change the PDO mapping in the following steps.

1. Set the number of entries of the sync manager 2 and sync manager 3 PDO assignment objects to 0.
2. Set the number of entries of the PDO mapping object to 0.
3. Change the PDO mapping object.
4. Change the number of entries of the PDO mapping object to the number of objects mapped in the step 3.
5. Change the sync manager 2 and sync manager 3 PDO assignment objects.
6. Change the number of entries of the sync manager 2 and sync manager 3 PDO assignment objects to the number assigned in the step 5.

■ Example of PDO mapping

This section introduces an example of PDO mapping. Data of 2 bytes and 4 bytes are little-endian. With the sync manager 2 and sync manager 3 PDO assignment objects, set the mapping of PDO communication by selecting the PDO mapping object that performs communication actually.

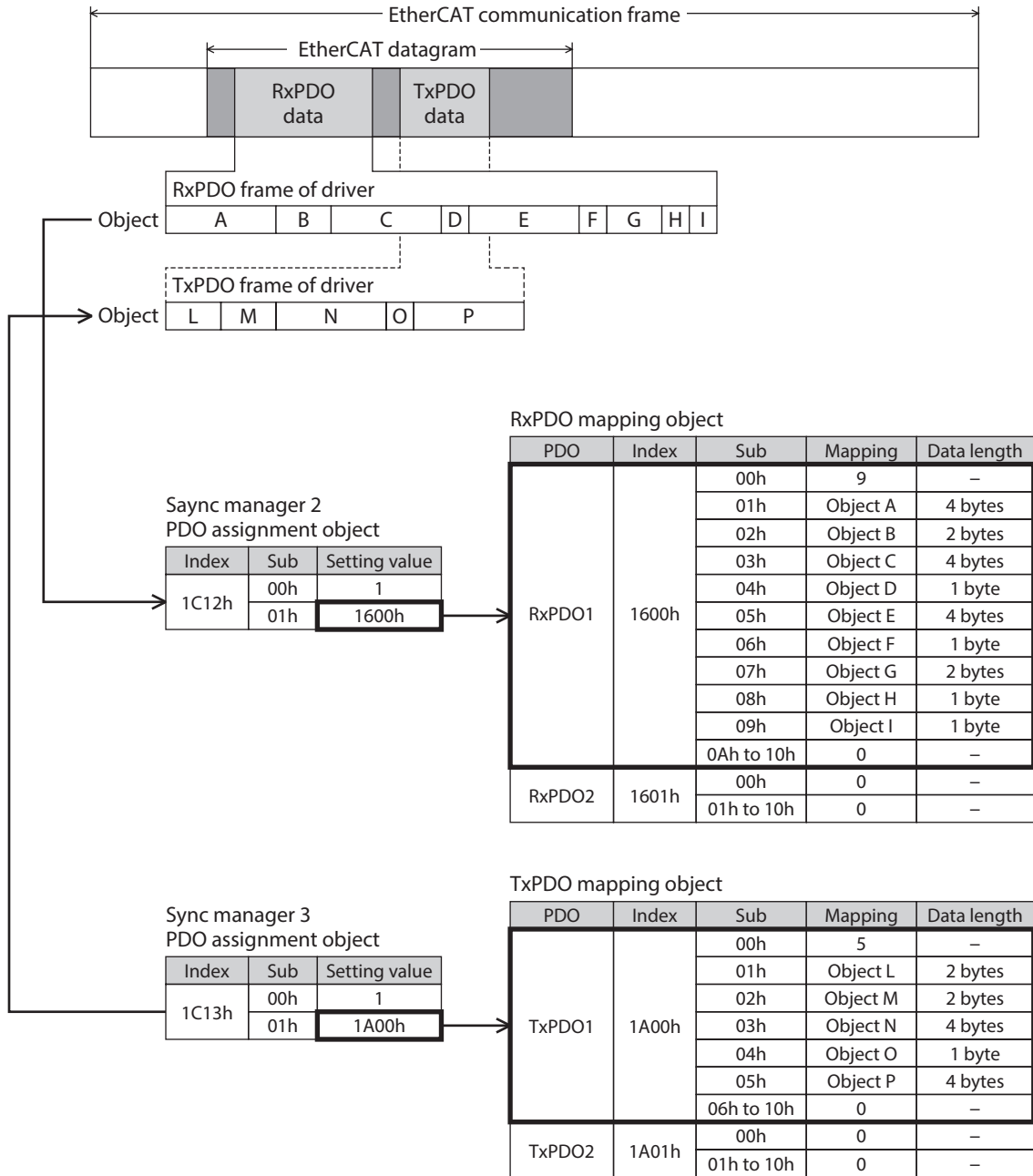

2-5 Service data object (SDO)

When read and write of the parameter object is performed, or monitor is executed via EtherCAT communication, the "Service data object (SDO)" is used. The SDO is not synchronized to EtherCAT communication cycles, but it is sent and received in an arbitrary timing. The setting of PDO mapping is also performed using the SDO.

■ SDO abort code

If an error occurs while the SDO is sent and received, an abort code is sent back. Abort code lists are shown in the table.

Abort code	Description
0503 0000h	Toggle bit did not inverted.
0504 0000h	SDO protocol timeout
0504 0001h	Client/server command specifier is not enabled or unknown.
0504 0005h	Out of range of memory
0601 0000h	Unsupported access to an object
0601 0001h	Read access was performed to a write only object.
0601 0002h	Write access was performed to a read only object.
0602 0000h	The object does not exist.
0604 0041h	The object can not be mapped in the PDO.
0604 0042h	The number of the PDO mappings or the data length exceeded the limitation.
0604 0043h	General parameter incompatibility
0604 0047h	General internal incompatibility in the device
0606 0000h	Access failed due to a hardware error
0607 0010h	Data type does not match, length of service parameter does not match.
0607 0012h	Data type does not match, length of service parameter is too long.
0607 0013h	Data type does not match, length of service parameter is too short.
0609 0011h	Sub-index does not exist.
0609 0030h	The setting range of the parameter was exceeded. (For write access)
0609 0031h	The value of the write parameter is too large.
0609 0032h	The value of the write parameter is too small.
0609 0036h	The maximum value is less than the minimum value.
0800 0000h	General error
0800 0020h	Data cannot be transferred or stored to the application.
0800 0021h	Data cannot be transferred or stored to the application because of local control.
0800 0022h	Data cannot be transferred or stored to the application in the present device status.
0800 0023h	Object dictionary cannot be generated or object dictionary does not exist.

2-6 Synchronous mode of EtherCAT communication

This product is compatible with three modes of EtherCAT communication.

- **Free run mode**

The driver operates in asynchronous to EtherCAT communication.
The communication cycle of the Free run mode is 1 ms or more.

- **Sync manager 2 event synchronization mode**

The driver operates in synchronization with EtherCAT communication. An application is synchronized with the sync manager 2 event. Whenever the driver receives the process data output (RxPDO), the sync manager 2 event is generated.
The communication cycle of the sync manager 2 event synchronization mode is 1 ms or more.

- **DC mode (SYNC0 event synchronization)**

The driver operates in synchronization with EtherCAT communication. An application is synchronized with the SYNC0 event.
The communication cycle of the DC mode is 0.25 ms, 0.5 ms, or 1 to 8 ms (in 1 ms unit).

2-7 Distributed clocks

The "Distributed clocks (DC)" is a method to synchronize an operation by sharing the same clock between the MainDevice and driver.

The interruption signal (SYNC0) is output at a precise interval based on the DC. In the DC mode, an application is executed in synchronization with SYNC0.

2-8 Emergency message

If an error occurs in the driver, an emergency message is sent to the MainDevice using the mailbox communication. The emergency message is sent only once per error. The emergency message consists of the following 8 bytes.

Byte0	Byte1	Byte2	Byte3	Byte4	Byte5	Byte6	Byte7
Emergency error code		Error register object (1001h)	Manufacturer-specific error definition field				

- **Emergency message for when an alarm is generated**

If an alarm is generated in the driver, an emergency message is sent to the MainDevice using the mailbox communication. The emergency message for when the alarm is generated consists of the following 8 bytes.

Byte0	Byte1	Byte2	Byte3	Byte4	Byte5	Byte6	Byte7
Emergency error code (FF00h)		Error register object (1001h)	Manufacturer-specific error definition field				
			0	Alarm code	0		

The emergency error code is FF00h regardless of the alarm contents.
The byte2 is the same value as the error register object.
The byte4 is the alarm code. Refer to p.219 for alarm code.

- **Emergency code for when the ESM transition error is generated**

If the transition from pre-operational to safe-operational was failed in the ESM, the following emergency code is sent.

Byte0	Byte1	Byte2	Byte3	Byte4	Byte5	Byte6	Byte7
Emergency error code (A000h)		Channel (02h)	Diagnosis data				
			0Ah	0			

If the transition from pre-operational to safe-operational was requested during the following status, this emergency code is generated. Check the contents, and reconsider the setting and other conditions.

- The unsupported communication cycle in the DC mode is set.
- The object that mapping is not possible is mapped in the PDO mapping.
- The object for TxPDO is mapped in RxPDO. Or the object for RxPDO is mapped in TxPDO.

3 Drive profile

3-1 Drive state machine

The drive state machine is controlled by the "Controlword object (6040h)." The status of each state can be checked by the "Statusword object (6041h)."

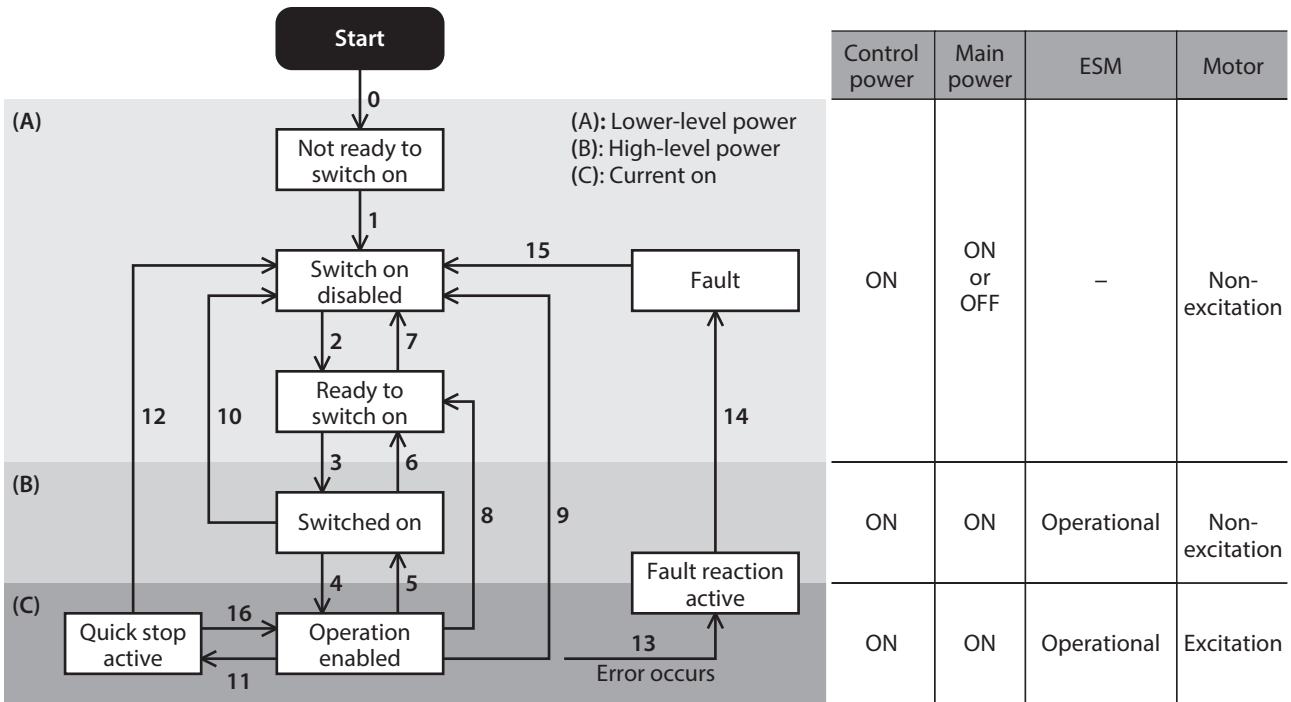

State	Status	Motor status	Parameter setting
Not ready to switch on	The control power supply was turned on, and the initialization processing is executing.	Non-excitation	Not possible to set
Switch on disabled	The initialization was complete.	Non-excitation	Possible to set
Ready to switch on	A state that the main power supply is possible to turn on.	Non-excitation	Possible to set
Switched on	A state that the main power supply was turned on.	Non-excitation	Possible to set
Operation enabled	The motor is in an excitation state, and the operation function is enabled.	Excitation	Possible to set
Quick stop active	The Quick stop command was received, and the operation stop is processing.	Excitation	Possible to set
Fault reaction active	An alarm was generated in the driver, and the operation stop is processing.	Excitation	Possible to set
Fault	An alarm is present in the driver.	Non-excitation	Possible to set

Note After moving to "Operation enabled," 250 ms is required until the motor is excited and the preparation for operation is completed. The motor does not start running even if the operation command is input before the preparation for operation is completed. Input the operation command after 250 ms have elapsed from having moved to "Operation enabled" or after the DCMD-RDY output is turned ON.

■ State transition of the drive state machine

The drive state machine is controlled by the "Controlword object (6040h)."

● Controlword object (6040h)

Bit15	Bit14	Bit13	Bit12	Bit11	Bit10	Bit9	Bit8
Manufacturer specific (ms)					Reserved	oms	Halt
Bit7	Bit6	Bit5	Bit4	Bit3	Bit2	Bit1	Bit0
Fault reset	Operation mode specific (oms)			Enable operation	Quick stop	Enable voltage	Switch on

● State transition commands by the controlword

State control command	Bit7	Bit3	Bit2	Bit1	Bit0	Transition number in the figure
Shutdown	–	–	1	1	0	2, 6, 8
Switch on	–	0	1	1	1	3 *
Switch on + enable operation	–	1	1	1	1	3+4 *
Disable voltage	–	–	–	0	–	7, 9, 10, 12
Quick stop	–	–	0	1	–	7, 10, 11
Disable operation	–	0	1	1	1	5
Enable operation	–	1	1	1	1	4, 16
Fault reset	0 to 1	–	–	–	–	15

* When the following conditions are not satisfied, the state will not move from "Ready to switch on" to "Switched on" even if the command is received.

- The status of the ESM is operational.
- The main power is turned ON.
- The FREE input is OFF.
- The CON input is OFF.
- The ETO-MON output is OFF.
- Test operation (remote operation) is not being executed using the **MEXE02**.

● State transition other than the above

Transition number in the figure	Transition event
0	Moves automatically when the control power supply is turned on.
1	Moves automatically when the initialization of the driver is complete.
12	If the Quick stop option code (605Ah) is 1 to 3, transitions to "Switch on disabled" after the motor stops when the Quick stop command is send.
13, 14	Moves if an alarm is generated.

If the drive state machine is in a state of any of "Switched on," "Operation enabled," or "Quick stop active," the state changes when an event in the table next is generated.

State	Motor operation	Event	Action
Switched on	During stop	<ul style="list-style-type: none"> • The ESM moves to other than OP. • The main power was cut off. • The driver is in the power removal status. • The FREE input is ON. 	Moves to "Ready to switch on." (Transition number 6)
Operation enabled	During stop	<ul style="list-style-type: none"> • The ESM moves to other than OP. • The main power was cut off. • The driver is in the power removal status. • The FREE input is ON. 	Moves to "Ready to switch on." (Transition number 8) The motor becomes in a non-excitation state.
	During operation	The ESM moves to other than OP.	The alarm of network bus error is generated (alarm code 81h). After moving from "Fault reaction active" to "Fault," the motor becomes in a non-excitation state. (Transition number 13, 14)

State	Motor operation	Event	Action
Operation enabled	During operation	The main power was cut off.	The alarm of main power supply off is generated (alarm code 23h). After moving from "Fault reaction active" to "Fault," the motor becomes in a non-excitation state. (Transition number 13, 14)
		<ul style="list-style-type: none"> • The driver is in the power removal status. • The FREE input is ON. 	Moves to "Ready to switch on." (Transition number 8) The motor becomes in a non-excitation state.
Quick stop active	During stop	<ul style="list-style-type: none"> • The ESM moves to other than OP. • The main power was cut off. • The driver is in the power removal status. • The FREE input is ON. 	Moves to "Switch on disabled." (Transition number 12) The motor becomes in a non-excitation state.
		The ESM moves to other than OP.	The alarm of network bus error is generated (alarm code 81h). After moving from "Fault reaction active" to "Fault," the motor becomes in a non-excitation state. (Transition number 13, 14)
	During operation	The main power was cut off.	The alarm of main power supply off is generated (alarm code 23h). After moving from "Fault reaction active" to "Fault," the motor becomes in a non-excitation state. (Transition number 13, 14)
		<ul style="list-style-type: none"> • The driver is in the power removal status. • The FREE input is ON. 	Moves to "Switch on disabled." (Transition number 12) The motor becomes in a non-excitation state.

■ Status output of the drive state machine

The status of the drive state machine is output by the "Statusword object (6041h)."

● Statusword object (6041h)

Bit15	Bit14	Bit13	Bit12	Bit11	Bit10	Bit9	Bit8
Manufacturer specific (ms)		Operation mode specific (oms)		Internal limit active	Target reached	Remote	ms
Bit7	Bit6	Bit5	Bit4	Bit3	Bit2	Bit1	Bit0
Warning	Switch on disabled	Quick stop	Voltage enabled	Fault	Operation enabled	Switched on	Ready to switch on

● Status output of the Statusword

State	Bit6	Bit5	Bit4	Bit3	Bit2	Bit1	Bit0
Start	0	0	0	0	0	0	0
Not ready to switch on	0	0	0	0	0	0	0
Fault	0	1	— *	1	0	0	0
Fault reaction active	0	1	— *	1	1	1	1
Switch on disabled	1	1	— *	0	0	0	0
Ready to switch on	0	1	— *	0	0	0	1
Switched on	0	1	— *	0	0	1	1
Operation enabled	0	1	— *	0	1	1	1
Quick stop active	0	0	— *	0	1	1	1

* Voltage enabled is 1 while the main power is input.

3-2 Operation mode

The driver supports the operation modes listed below.

- Cyclic synchronous position mode (CSP)
- Profile position mode (PP)
- Cyclic synchronous velocity mode (CSV)
- Profile velocity mode (PV)
- Homing mode (HM)

■ Switching of operation modes

The operation mode can be switched by the "Modes of operation (6060h)."

Setting value of the operation mode	Operation mode
0 (Initial value)	Operation function disable
1	Profile position mode (PP)
3	Profile velocity mode (PV)
6	Homing mode (HM)
8	Cyclic synchronous position mode (CSP)
9	Cyclic synchronous velocity mode (CSV)

Switch the operation mode while an operation is stopped. When it was switched during operation, the new operation mode will be enabled after the operation is stopped.

The operation mode which is enabled can be checked in the "Modes of operation display (6061h)."

3-3 Cyclic synchronous position mode (CSP)

In the cyclic synchronous position mode, a path generation (profile generation) is performed by the MainDevice. By cyclic synchronous communication, when the "Target position (607Ah)" is sent from the MainDevice to the driver, the driver performs position controls.

Use the cyclic synchronous position mode when EtherCAT communication is performed in the DC mode. If the cyclic synchronous position mode is used in the free run mode or sync manager2 event synchronization mode, the speed fluctuation or vibration may increase.

- Note**
- Since the position is controlled by the MainDevice in the cyclic synchronous position mode, if the operation is stopped without the MainDevice, the position deviation may cause. When inputting the stop signal such as the STOP input or the FREE input or when executing the power removal function, be sure to perform the following operations to clear the position deviation. If the stop signal is turned OFF while the position deviation is remained or if the ETO-CLR input is turned ON after the power removal status is released, the motor may start running suddenly.
 - Execute the operation stop from the MainDevice.
 - Clear the position deviation between the MainDevice and driver.
 - Since the position is controlled by the MainDevice in the cyclic synchronous position mode, executing the position preset (P-PRESET) in the driver during the motor excitation state will cause the motor to start suddenly or an alarm of command pulse error to generate. Stop the motor execution before executing the position preset (P-PRESET) in the driver.

Related object

Index	Sub	Name	Type	Access	PDO	Save	Range	Update
6040h	00h	Controlword	U16	RW	RxPDO	–	0000h to FFFFh (Initial value: 0000h)	A
6041h	00h	Statusword	U16	RO	TxPDO	–	–	–
6060h	00h	Modes of operation	INT8	RW	RxPDO	○	0 (Initial value), 1, 3, 6, 8, 9 (⇒ "Switching of operation modes")	B
6061h	00h	Modes of operation display	INT8	RO	TxPDO	–	–	–
6062h	00h	Position demand value [step]	INT32	RO	TxPDO	–	–	–

Index	Sub	Name	Type	Access	PDO	Save	Range	Update
6064h	00h	Position actual value [step]	INT32	RO	TxPDO	–	–	–
607Ah	00h	Target position [step]	INT32	RW	RxPDO	–	–2,147,483,648 to 2,147,483,647 (Initial value: 0)	A
607Dh	01h	Min. position limit [step]	INT32	RW	No	○	–2,147,483,648 to 2,147,483,647 (Initial value: –2,147,483,648)	A
	02h	Max. position limit [step]	INT32	RW	No	○	–2,147,483,648 to 2,147,483,647 (Initial value: 2,147,483,647)	A

■ Controlword of the cyclic synchronous position mode

Bit15	Bit14	Bit13	Bit12	Bit11	Bit10	Bit9	Bit8
Manufacturer specific (ms)					Reserved	oms	Halt
–	–	–	–	–		–	
Bit7	Bit6	Bit5	Bit4	Bit3	Bit2	Bit1	Bit0
Fault reset	Operation mode specific (oms)			Enable operation	Quick stop	Enable voltage	Switch on
	–	–	–				

Details of controlword

Bit	Name	Value	Description
8	Halt	0	Operation allowed
		1	Stop operation. The stopping method is "Immediate stop."

For the bit7 and bit3 to bit0, refer to "State transition of the drive state machine" on p.111.

■ Statusword of the cyclic synchronous position mode

Bit15	Bit14	Bit13	Bit12	Bit11	Bit10	Bit9	Bit8
Manufacturer specific		Operation mode specific		Internal limit active	–	Remote	ms
TLC	–	Following error	Target position ignored				–
Bit7	Bit6	Bit5	Bit4	Bit3	Bit2	Bit1	Bit0
Warning	Switch on disabled	Quick stop	Voltage enabled	Fault	Operation enabled	Switched on	Ready to switch on

Details of statusword

Bit	Name	Value	Description
15	TLC	0	A load does not reach the upper limit of the motor output torque.
		1	A load reached the upper limit of the motor output torque.
13	Following error	0	Position deviation error not present
		1	Position deviation error present The position deviation exceeded the value set in the "Following error window (6065h)." The value changes to 0 when the alarm of excessive position deviation (alarm code 10h) or the alarm of overload (alarm code 30h) is cleared.
12	Target position ignored	0	Target position command disable When the state is any of the followings, the value is 0, and the target position is disabled. <ul style="list-style-type: none"> • The drive state machine is other than "Operation enabled." • The motor is in a non-excitation state. • "Halt (6040h: bit8)" has been 1. • The STOP input is ON. • The internal limit is in an active state.
		1	Target position command enable

Bit	Name	Value	Description
11	Internal limit active	0	The function limitation by the internal limit is not in an active state.
		1	The function limitation by the internal limit became an active state. The value is 1 when any of the following internal limit function is activated. <ul style="list-style-type: none"> • Limit sensor (FW-LS/RV-LS) • Operation prohibition input (FW-BLK/RV-BLK) • Software limit • Mechanical limit
9	Remote	1	The value becomes 1 when the initialization is complete.
7	Warning	0	Information not present When the causes of information are cleared, the "Warning" is automatically cleared to 0.
		1	Information present

For the bit6 to bit0, refer to "Status output of the drive state machine" on p.112.

3-4 Profile position mode (PP)

The profile position mode operates in the internal profile of the driver. A path generation (profile generation) is performed in the driver. The target position, velocity, acceleration and others are set in the MainDevice.

Related object

Index	Sub	Name	Type	Access	PDO	Save	Range	Update
6040h	00h	Controlword	U16	RW	RxPDO	–	0000h to FFFFh (Initial value: 0000h)	A
6041h	00h	Statusword	U16	RO	TxPDO	–	–	–
6060h	00h	Modes of operation	INT8	RW	RxPDO	○	0 (Initial value), 1, 3, 6, 8, 9 (⇒ p.113)	B
6061h	00h	Modes of operation display	INT8	RO	TxPDO	–	–	–
6062h	00h	Position demand value [step]	INT32	RO	TxPDO	–	–	–
6064h	00h	Position actual value [step]	INT32	RO	TxPDO	–	–	–
607Ah	00h	Target position [step]	INT32	RW	RxPDO	–	–2,147,483,648 to 2,147,483,647 (Initial value: 0)	A
607Dh	01h	Min. position limit [step]	INT32	RW	No	○	–2,147,483,648 to 2,147,483,647 (Initial value: –2,147,483,648)	A
	02h	Max. position limit [step]	INT32	RW	No	○	–2,147,483,648 to 2,147,483,647 (Initial value: 2,147,483,647)	A
607Fh	00h	Max profile velocity [Hz]	U32	RW	RxPDO	○	0 to 4,000,000 (Initial value: 1,000,000)	B
6081h	00h	Profile velocity [Hz]	U32	RW	RxPDO	○	0 to 4,000,000 (Initial value: 10,000)	B
6083h	00h	Profile acceleration [step/s ²]	U32	RW	RxPDO	○	1 to 1,000,000,000 (Initial value: 300,000)	B
6084h	00h	Profile deceleration [step/s ²]	U32	RW	RxPDO	○	1 to 1,000,000,000 (Initial value: 300,000)	B
4142h	00h	Starting speed [Hz]	INT32	RW	RxPDO	○	0 to 4,000,000 (Initial value: 5,000)	B
414Fh	00h	Wrap positioning mode	U8	RW	RxPDO	○	0: Wrap absolute positioning 1: Wrap proximity 2: Wrap forward direction 3: Wrap reverse direction (Initial value: 0)	B

■ Controlword of the profile position mode

Bit15	Bit14	Bit13	Bit12	Bit11	Bit10	Bit9	Bit8
Manufacturer specific (ms)					Reserved	oms	Halt
–	Wrap	Push	Base position of Rel	–		Change on set point	
Bit7	Bit6	Bit5	Bit4	Bit3	Bit2	Bit1	Bit0
Fault reset	Operation mode specific (oms)			Enable operation	Quick stop	Enable voltage	Switch on
	Abs/Rel	Change set immediately	New set point				

Details of controlword

Bit	Name	Value	Description
14	Wrap	1	Wrap absolute positioning operation After the "Wrap" is set to 1, when an operation is started by setting the "New set point (6040h: bit4)" to 1, wrap absolute positioning operation is performed. The operating method is in accordance with the setting of the "Wrap positioning mode (414Fh)."
13	Push	1	Push-motion positioning operation After the "Push" is set to 1, when an operation is started by setting the "New set point (6040h: bit4)" to 1, push-motion positioning operation is performed. The "Push current (4121h)" is applied to the motor current. When the "Halt (6040h: bit8)" is set to 1, or when the STOP input is turned ON, the operation is stopped. The "Stop current (4128h)" is applied to the motor current at standstill.
12	Base position of Rel	0	Incremental positioning operation (based on command position) Positioning operation of the set travel amount is performed from the present command position. The travel amount is set with the "Target position (607Ah)."
		1	Incremental positioning operation (based on actual position) Positioning operation of the set travel amount is performed from the present actual position. The travel amount is set with the "Target position (607Ah)."
10	Reserved	–	Reserved
9	Change on set point	–	Not supported.
8	Halt	0	Operation allowed
		1	Stops operation. The stopping method is in accordance with the setting of the "Halt option code (605Dh)."
6	Abs/Rel	0	Absolute positioning operation The "Target position (607Ah)" is the target position of absolute positioning operation.
		1	Incremental positioning operation The "Target position (607Ah)" is the target position of incremental positioning operation.
5	Change set immediately	0	When the "New set point (6040h: bit4)" is changed from 0 to 1 during operation, the new operation command is stored. When the present operation is complete, the stored new operation command is started.
		1	When the "New set point (6040h: bit4)" is changed from 0 to 1 during operation, the new operation command is immediately applied. During push-motion operation, when the New set point (6040h: bit4) is set from 0 to 1 to start new operation, set the Change set immediately to 1.

Bit	Name	Value	Description
4	New set point	0 → 1	<p>Starting of positioning operation Before starting the operation, select the "Wrap (6040h: bit14)", "Push (6040h: bit13)", "Base position of Rel (6040h: bit12)" and "Abs/Rel (6040h: bit6)."</p> <p>If positioning operation is executed in a state where the operation is stopped by changing the "Halt (6040h: bit8)" to 1, change the "Halt (6040h: bit8)" from 1 to 0 first, and then leave an interval at more than double of the communication cycle before changing the "New set point (6040h: bit4)" from 0 to 1. The operation may not be started unless the interval at more than double of the communication cycle is left.</p> <p>The command cannot be received in the following status, and the operation is not started.</p> <ul style="list-style-type: none"> • "Halt (6040h: bit8)" has been 1. • The STOP input is ON. • The drive state machine is other than "Operation enabled." • The motor is in a non-excitation state.

For the bit7 and bit3 to bit0, refer to "State transition of the drive state machine" on p.111.

■ Statusword of the profile position mode

Bit15	Bit14	Bit13	Bit12	Bit11	Bit10	Bit9	Bit8
Manufacturer specific		Operation mode specific		Internal limit active	Target reached	Remote	ms
TLC	–	Following error	Set point acknowledge				–
Bit7	Bit6	Bit5	Bit4	Bit3	Bit2	Bit1	Bit0
Warning	Switch on disabled	Quick stop	Voltage enabled	Fault	Operation enabled	Switched on	Ready to switch on

Details of statusword

Bit	Name	Value	Description
15	TLC	0	A load does not reach the upper limit of the motor output torque.
		1	A load reached the upper limit of the motor output torque. When push-motion operation is performed, use this signal as the completion signal of push-motion operation.
13	Following error	0	Position deviation error not present
		1	Position deviation error present The position deviation exceeded the value set in the "Following error window (6065h)." The value changes to 0 when the alarm of excessive position deviation (alarm code 10h) or the alarm of overload (alarm code 30h) is cleared.
12	Set point acknowledge	0	The operation start by the "New set point (6040h: bit4)" has not been received.
		1	The operation start by the "New set point (6040h: bit4)" was received. When the "New set point (6040h: bit4)" is set to 1 and the operation start is received, the "Set point acknowledge" changes to 1. When the "New set point (6040h: bit4)" is set to 0, the "Set point acknowledge" also changes to 0.
11	Internal limit active	0	The function limitation by the internal limit is not in an active state.
		1	The function limitation by the internal limit became an active state. The value is 1 when any of the following internal limit function is activated. <ul style="list-style-type: none"> • Limit sensor (FW-LS/RV-LS) • Operation prohibition input (FW-BLK/RV-BLK) • Software limit • Mechanical limit

Bit	Name	Value	Description
10	Target reached	0	<ul style="list-style-type: none"> When the "Halt (6040h: bit8)" is 0: The positioning operation is not complete. When the "Halt (6040h: bit8)" is 1: During deceleration stop.
		1	<ul style="list-style-type: none"> When the "Halt (6040h: bit8)" is 0: After positioning operation is properly completed, the value changes to 1 when the feedback position has converged in a range of the Position window (6067h) with respect to the command position. It does not change to 1 when the positioning operation was interrupted on the way. It changes to 0 if the operation is started from a state where the positioning was complete. When the "Halt (6040h: bit8)" is 1: The value changes to 1 when the operation velocity demand value becomes 0.
9	Remote	1	The value becomes 1 when the initialization is complete.
7	Warning	0	Information not present When the causes of information are cleared, the "Warning" is automatically cleared to 0.
		1	Information present.

For the bit6 to bit0, refer to "Status output of the drive state machine" on p.112.

■ Operation in the profile position mode

● Positioning operation

Positioning operation is started when the "Target position (607Ah)" is set and the "New set point (6040h: bit4)" is set to 1.

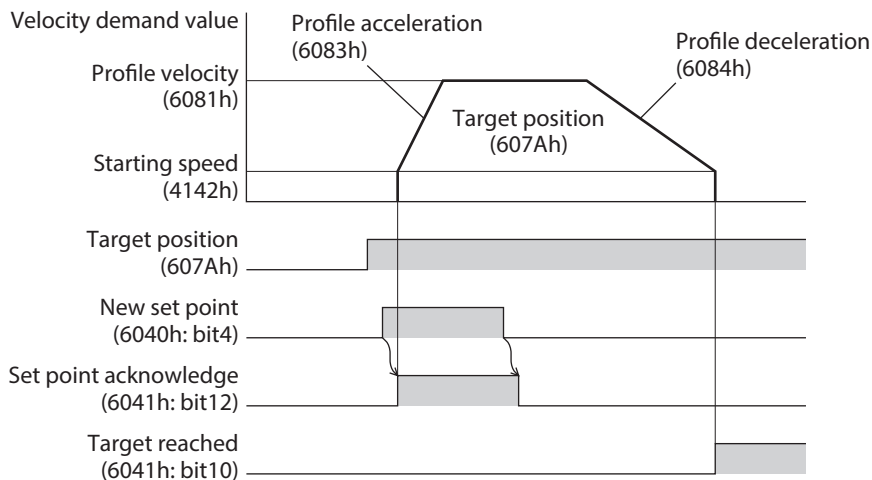

Single set-point [When the "Change set immediatly (6040h: bit5)" is 1]

If the "New set point (6040h: bit4)" is set during operation, the new operation command is applied immediately.

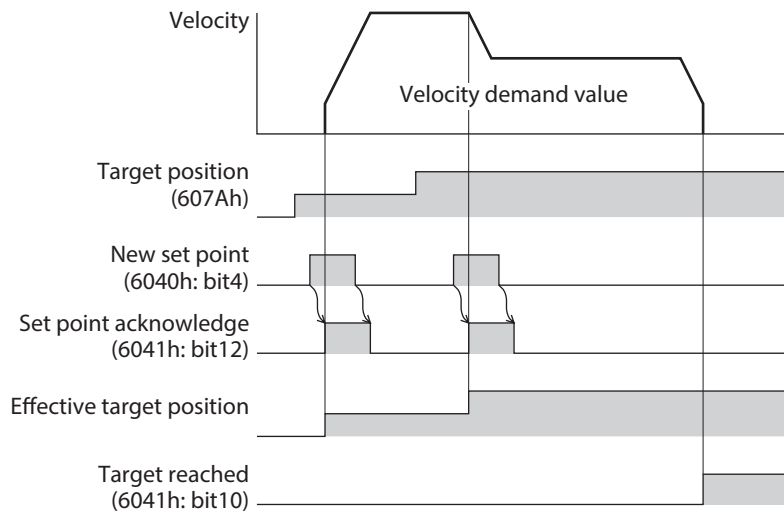

Set of set-points [When the "Change set immediatly (6040h: bit5)" is 0]

If the "New set point (6040h: bit4)" is set during operation, the new operation command is stored. When the present operation is complete, the stored new operation command is started.

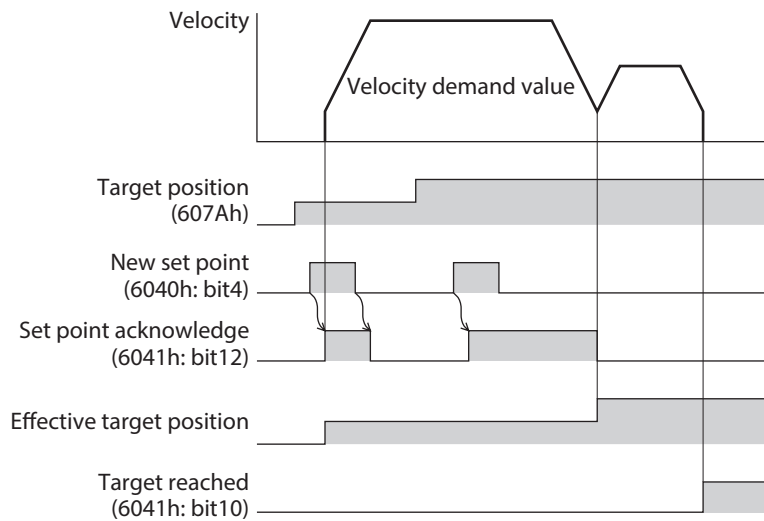

● **Push-motion positioning operation**

After the "Push (6040h: bit13)" is set to 1, when the "New set point (6040h: bit4)" is set to 1, push-motion positioning operation is started. If push-motion positioning operation is started, self-start operation (rectangular operation) is performed at the operating speed set in the "Profile velocity (6081h)."

During push-motion operation, when the New set point (6040h: bit4) is set from 0 to 1 to start new operation, set the Change set immediately (6040h: bit5) to 1.

Note

- When a mechanism installed to the motor pressed against a load, push-motion operation is performed while a position deviation of 2.7° generates. An alarm of overload may be generated if the operation is stopped in this state, so perform operation to return the actual position by 3.6° before push-motion operation is stopped.
- Do not perform push-motion operation with geared motors and **DGII** Series. Doing so may cause damage to the motor or gear part.
- When push-motion operation is stopped in a state where a load is pressed, set the "Operating current (4120h)" of the next operation to be executed, to a value in the "Push current (4121h)" or less. If a higher current value than the "Push current (4121h)" is set, the push current may increase when an operation is transited, causing an unexpected push force to apply.

When a mechanism installed to the motor had presses against a load

When a load is pressed, the "TLC (6041h: bit15)" of the statusword changes to 1.

If the "Halt (6040h: bit8)" of the controlword is set to 1 or the STOP input is turned ON, the operation is stopped and the push-motion status is canceled.

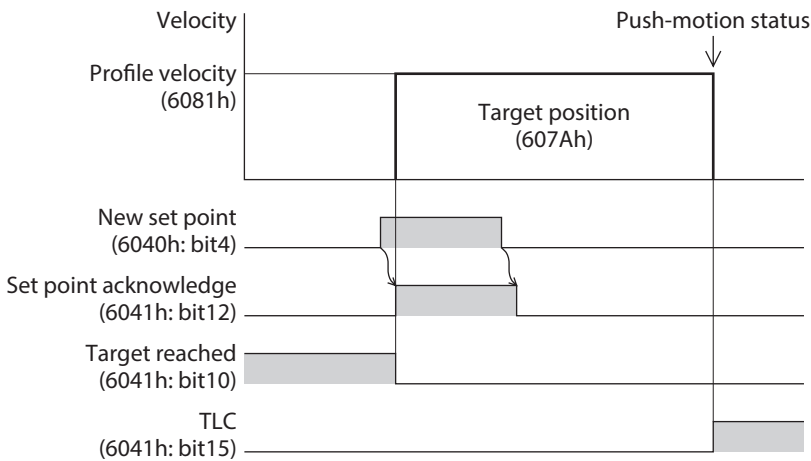

When a mechanism installed to the motor had not presses against a load

If the motor reaches the target position without pressing a load, the operation is complete. The "TLC (6041h: bit15)" does not change to 1.

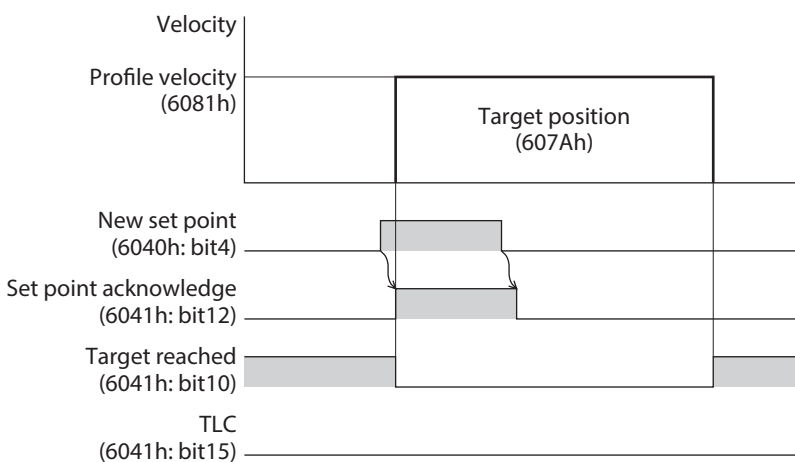

● **Wrap absolute positioning operation**

If the "New set point (6040h: bit4)" is changed to 1 after the "Target position (607Ah)" was set and the "Wrap (6040h: bit14)" was changed to 1, wrap absolute positioning operation is started. With wrap absolute positioning operation, absolute positioning operation is performed regardless of the value of the "Abs/Rel (6040h: bit6)."



When wrap absolute positioning operation is performed, set the "Wrap setting (41C7h)" to "1: Enable."

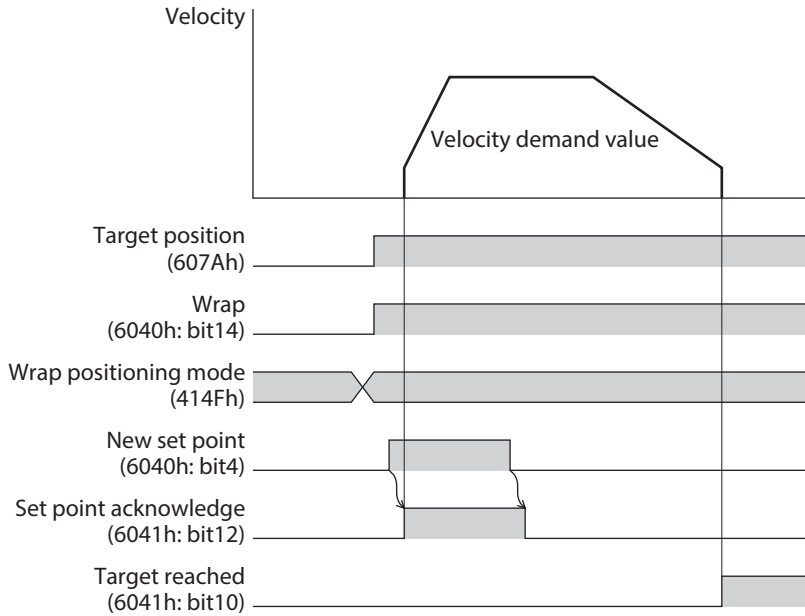

■ **Operation mode of the profile position mode**

The operation mode of the profile position mode is set with the "Controlword (6040h)" and the "Wrap positioning mode (414Fh)." The operation modes are listed in the table.

Operation mode	Wrap positioning mode (414Fh)	Controlword (6040h)			
		Wrap (Bit14)	Push (Bit13)	Base position of Rel (Bit12)	Abs/Rel (Bit6)
Absolute positioning	–	0	0	–	0
Incremental positioning (based on command position)	–	0	0	0	1
Incremental positioning (based on actual position)	–	0	0	1	1
Absolute positioning push-motion	–	0	1	–	0
Incremental positioning push-motion (based on command position)	–	0	1	0	1
Incremental positioning push-motion (based on actual position)	–	0	1	1	1
Wrap absolute positioning	0	1	0	–	–
Wrap proximity positioning	1	1	0	–	–
Wrap forward direction absolute positioning	2	1	0	–	–
Wrap reverse direction absolute positioning	3	1	0	–	–
Wrap absolute push-motion	0	1	1	–	–
Wrap proximity push-motion	1	1	1	–	–
Wrap forward direction push-motion	2	1	1	–	–
Wrap reverse direction push-motion	3	1	1	–	–

● **Absolute positioning**

Positioning operation is performed from the present position to the set target position. In the "Target position (607Ah)," set the target position on the coordinates with the home as a reference.

Example: When moving from the command position "1,000" to the target position "4,000"

Set 4,000 steps in the "Target position (607Ah)" to start absolute positioning operation.

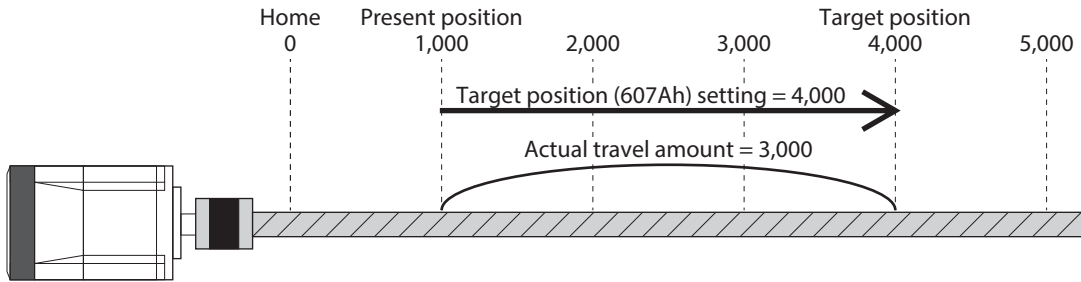

● **Incremental positioning (based on command position)**

Positioning operation of the set travel amount is performed from the present command position. In the "Target position (607Ah)," set the travel amount from the present command position to the target position.

Example: When moving from the command position "1,000" to the target position "4,000"

Set 3,000 steps in the "Target position (607Ah)" to start incremental positioning (based on command position) operation.

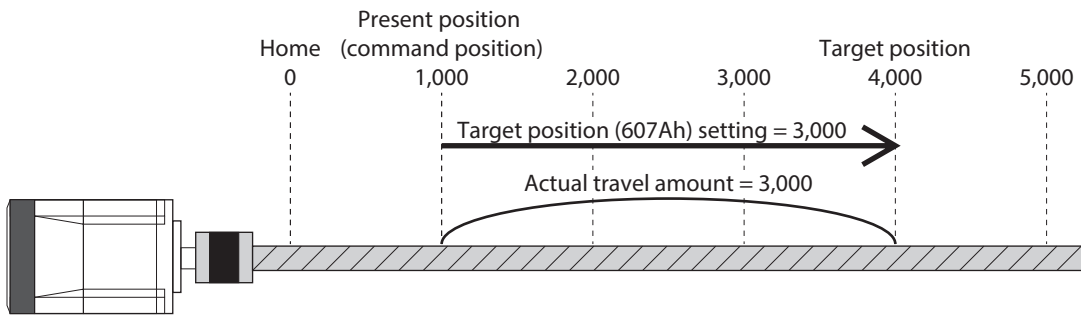

● **Incremental positioning (based on actual position)**

Positioning operation of the set travel amount is performed from the present actual position. In the "Target position (607Ah)," set the travel amount from the actual position.

Example: When moving 3,000 steps from the command position "1,000" and the actual position "900"

Set 3,000 steps in the "Target position (607Ah)" to start incremental positioning (based on actual position) operation. The command position and the actual position after completing the operation will be "3,900."

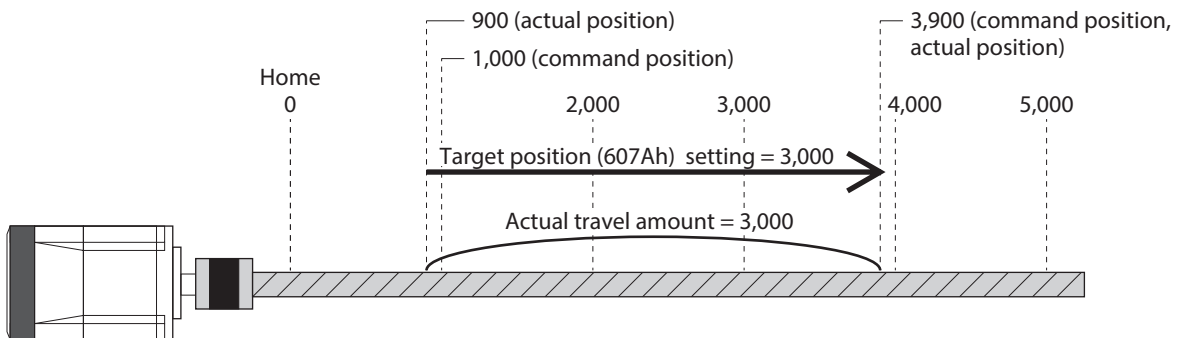

- The reference position of the operation based on the actual position varies depending on the load.
- If the command position and the actual position are different such as push-motion operation, the next operation can be started based on the actual position of the push position or others.

● **Wrap absolute positioning**

Positioning operation is performed to the target position within the wrap range. In the "Target position (607Ah)," set the target position within the wrap range. Refer to p.151 for the wrap function.

Example: When moving from the command position "1,000" to the target position "4,000"
 (Wrap setting range 1.0 rev, wrap offset ratio 50.00 %)

Set the items in the table to start wrap absolute positioning operation.

Index	Name	Setting value
41C7h	Wrap setting	1: Enable
41C9h	Initial coordinate generation & wrap setting range [1=0.1 rev]	10
41CBh	Initial coordinate generation & wrap range offset ratio [1=0.01 %]	5,000
414Fh	Wrap positioning mode	0: Wrap absolute positioning
607Ah	Target position [step]	4,000

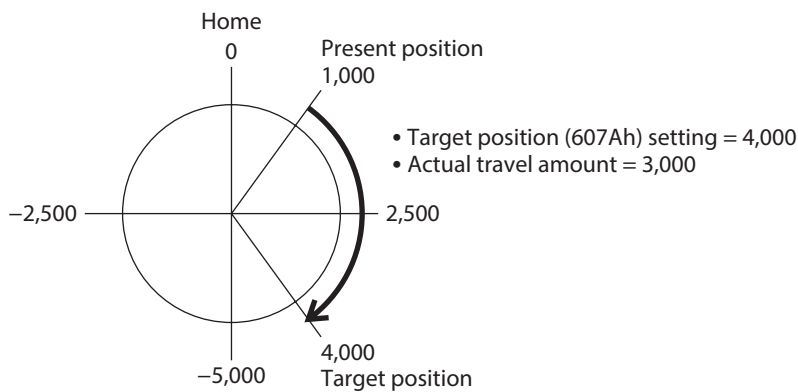

● **Wrap proximity positioning**

Positioning operation in the shortest distance is performed to the target position within the wrap range. In the "Target position (607Ah)," set the target position within the wrap range. Refer to p.151 for the wrap function.

Example: When moving from the command position "-4,000" to the target position "4,000"
 (Wrap setting range 1.0 rev, wrap offset ratio 50.00 %)

Set the items in the table to start wrap proximity positioning operation.

Index	Name	Setting value
41C7h	Wrap setting	1: Enable
41C9h	Initial coordinate generation & wrap setting range [1=0.1 rev]	10
41CBh	Initial coordinate generation & wrap range offset ratio [1=0.01 %]	5,000
414Fh	Wrap positioning mode	1: Wrap proximity
607Ah	Target position [step]	4,000

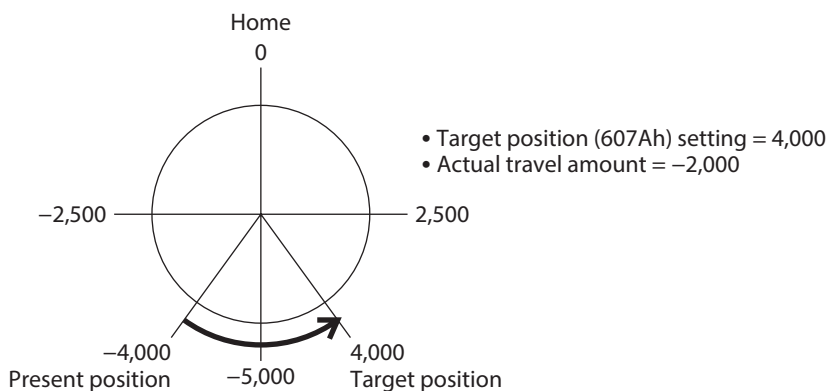

● **Wrap forward direction absolute positioning**

Positioning operation in the forward direction is performed to the target position within the wrap range. In the "Target position (607Ah)," set the target position within the wrap range. Refer to p.151 for the wrap function.

Example: When moving from the command position "1,000" to the target position "-4,000"
(Wrap setting range 1.0 rev, wrap offset ratio 50.00 %)

Set the items in the table to start wrap forward direction absolute positioning operation.

Index	Name	Setting value
41C7h	Wrap setting	1: Enable
41C9h	Initial coordinate generation & wrap setting range [1=0.1 rev]	10
41CBh	Initial coordinate generation & wrap range offset ratio [1=0.01 %]	5,000
414Fh	Wrap positioning mode	2: Wrap forward direction
607Ah	Target position [step]	-4,000

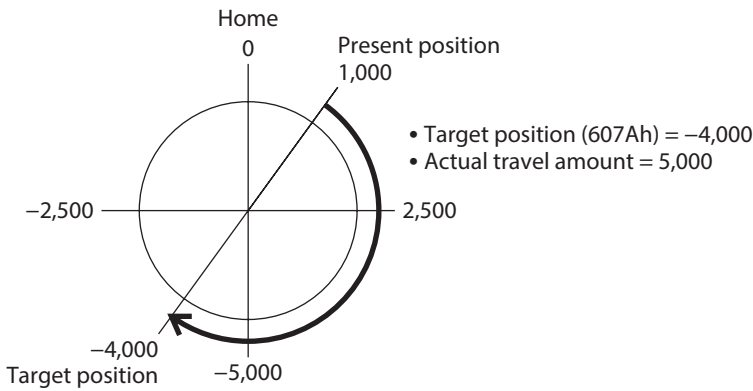

● **Wrap reverse direction absolute positioning**

Positioning operation in the reverse direction is performed to the target position within the wrap range. In the "Target position (607Ah)," set the target position within the wrap range. Refer to p.151 for the wrap function.

Example: When moving from the command position "1,000" to the target position "4,000"
(Wrap setting range 1.0 rev, wrap offset ratio 50.00 %)

Set the items in the table to start wrap reverse direction absolute positioning operation.

Index	Name	Setting value
41C7h	Wrap setting	1: Enable
41C9h	Initial coordinate generation & wrap setting range [1=0.1 rev]	10
41CBh	Initial coordinate generation & wrap range offset ratio [1=0.01 %]	5,000
414Fh	Wrap positioning mode	3: Wrap reverse direction
607Ah	Target position [step]	4,000

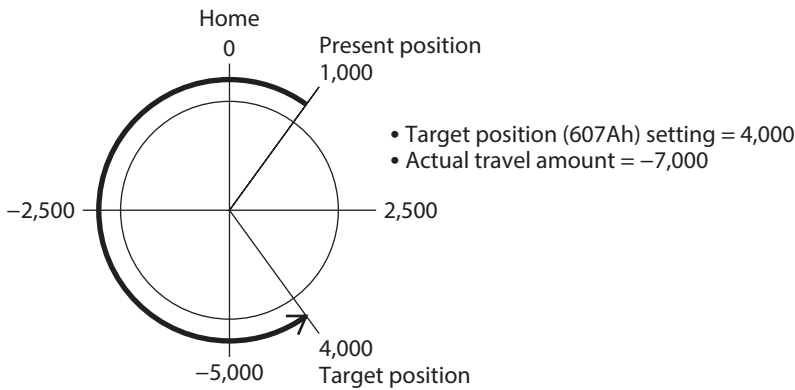

■ Orbit comparison of positioning operation

These are examples for when the wrap setting range is set to 1 rev and the wrap range offset ratio is set to 50 %.

Operation mode	Initial value → The value set in the "Target position (607Ah)"	
	2,500 → 9,000	2,500 → -14,000
<ul style="list-style-type: none"> • Absolute positioning <p>Sets the coordinate of the target position from the home</p>		
<ul style="list-style-type: none"> • Incremental positioning (based on command position) • Incremental positioning (based on actual position) <p>Sets the travel amount from the command position or the actual position to the target position.</p>		
<ul style="list-style-type: none"> • Wrap absolute positioning <p>Sets the target position on coordinates with the home as a reference. Operation is performed within the wrap range.</p>		
<ul style="list-style-type: none"> • Wrap proximity positioning <p>Sets the target position on coordinates with the home as a reference. Operation in the shortest distance is performed to the target position within the wrap range.</p>		
<ul style="list-style-type: none"> • Wrap forward direction absolute positioning <p>Sets the target position on coordinates with the home as a reference. Operation in the forward direction is performed to the target position within the wrap range.</p>		
<ul style="list-style-type: none"> • Wrap reverse direction absolute positioning <p>Sets the target position on coordinates with the home as a reference. Operation in the reverse direction is performed to the target position within the wrap range.</p>		

* The value □ represents the coordinate of the position where the motor stopped.

3-5 Cyclic synchronous velocity mode (CSV)

In the cyclic synchronous velocity mode, a path generation (profile generation) is performed by the MainDevice. By cyclic synchronous communication, when the "Target velocity (60FFh)" is sent from the MainDevice to the driver, the driver performs speed controls.

Related object

Index	Sub	Name	Type	Access	PDO	Save	Range	Update
6040h	00h	Controlword	U16	RW	RxPDO	–	0000h to FFFFh (Initial value: 0000h)	A
6041h	00h	Statusword	U16	RO	TxPDO	–	–	–
6060h	00h	Modes of operation	INT8	RW	RxPDO	○	0(Initial value), 1, 3, 6, 8, 9 (⇒ p.113)	B
6061h	00h	Modes of operation display	INT8	RO	TxPDO	–	–	–
606Bh	00h	Velocity demand value [Hz]	INT32	RO	TxPDO	–	–	–
606Ch	00h	Velocity actual value [Hz]	INT32	RO	TxPDO	–	–	–
60FFh	00h	Target velocity [Hz]	INT32	RW	RxPDO	–	–4,000,000 to 4,000,000 (Initial value: 0)	A

■ Controlword of the cyclic synchronous velocity mode

Bit15	Bit14	Bit13	Bit12	Bit11	Bit10	Bit9	Bit8
Manufacturer specific (ms)					Reserved	oms	Halt
–	–	Type		–		–	
Bit7	Bit6	Bit5	Bit4	Bit3	Bit2	Bit1	Bit0
Fault reset	Operation mode specific (oms)			Enable operation	Quick stop	Enable voltage	Switch on
	–	–	–				

Details of controlword

Bit	Name	Value	Description
13	Type	–	The operation mode of the cyclic synchronous velocity mode is selected. The operation mode changed is updated immediately. For details, refer to "Operation mode of the cyclic synchronous velocity mode" on p.127.
12		–	
8	Halt	0	Operation allowed
		1	Stops operation. The stopping method is "Immediate stop."

For the bit7 and bit3 to bit0, refer to "State transition of the drive state machine" on p.111.

■ Operation mode of the cyclic synchronous velocity mode

The operation mode of the cyclic synchronous velocity mode is set with the "Type (6040h: bit13, bit12)." The operation modes are as shown in the table.

Bit13	Bit12	Operation mode	Explanation
0	0	Continuous operation (Position control)	Continuous operation is executed at the "Target velocity (60FFh)." Operation is executed while the position deviation is monitored, so when a load exceeding the torque of the motor is applied, an alarm of overload or excessive position deviation is generated. If sudden position deviation occurs, for example, when a large load is removed, the motor accelerates suddenly or has overspeed to remove deviation.
0	1	Continuous operation (Speed control)	Continuous operation is executed at the "Target velocity (60FFh)." When a load exceeding the torque of the motor is applied, an alarm of overload is generated.
1	0	Continuous operation (Push-motion) *	Continuous operation is executed at the "Target velocity (60FFh)." When a mechanism installed to the motor presses against a load, pressure is continuously applied to the load.
1	1	Continuous operation (Torque control) *	In the cyclic synchronous velocity mode, it is the same movement as continuous operation (push-motion) and continuous operation (torque control).

Note * When continuous operation (push-motion) or continuous operation (torque control) is performed, note the following.

- When a mechanism installed to the motor pressed against a load, push-motion operation is performed while a position deviation of 2.7° generates. An alarm of overload may be generated if the operation is stopped in this state, so perform operation to return the actual position by 3.6° before push-motion operation is stopped.
- Do not perform push-motion operation with geared motors and **DGII** Series. Doing so may cause damage to the motor or gear part.
- When push-motion operation is stopped in a state where a load is pressed, set the "Operating current (4120h)" of the next operation to be executed, to a value in the "Push current (4121h)" or less. If a higher current value than the "Push current (4121h)" is set, the push current may increase when an operation is transited, causing an unexpected push force to apply.

■ Statusword of the cyclic synchronous velocity mode

Bit15	Bit14	Bit13	Bit12	Bit11	Bit10	Bit9	Bit8
Manufacturer specific		Operation mode specific		Internal limit active	Reserved	Remote	ms
TLC	–	Reserved	Target velocity ignored				–
Bit7	Bit6	Bit5	Bit4	Bit3	Bit2	Bit1	Bit0
Warning	Switch on disabled	Quick stop	Voltage enabled	Fault	Operation enabled	Switched on	Ready to switch on

Details of statusword

Bit	Name	Value	Description
15	TLC	0	A load does not reach the upper limit of the motor output torque.
		1	A load reached the upper limit of the motor output torque.
13	Reserved	0	Reserved
12	Target velocity ignored	0	Target speed command disable When the state is any of the followings, the value is 0, and the target speed is disabled. <ul style="list-style-type: none"> • The drive state machine is other than "Operation enabled." • The motor is in a non-excitation state. • "Halt (6040h: bit8)" has been 1. • The STOP input is ON. • The internal limit is in an active state.
		1	Target speed command enable
11	Internal limit active	0	The function limitation by the internal limit is not in an active state.
		1	The function limitation by the internal limit became an active state. The value is 1 when any of the following internal limit function is activated. <ul style="list-style-type: none"> • Limit sensor (FW-LS/RV-LS) • Operation prohibition input (FW-BLK/RV-BLK) • Software limit • Mechanical limit
10	Reserved	0	Reserved
9	Remote	1	The value becomes 1 when the initialization is complete.
7	Warning	0	Information not present When the causes of information are cleared, the "Warning" is automatically cleared to 0.
		1	Information present

For the bit6 to bit0, refer to "Status output of the drive state machine" on p.112.

■ Operation in the cyclic synchronous velocity mode

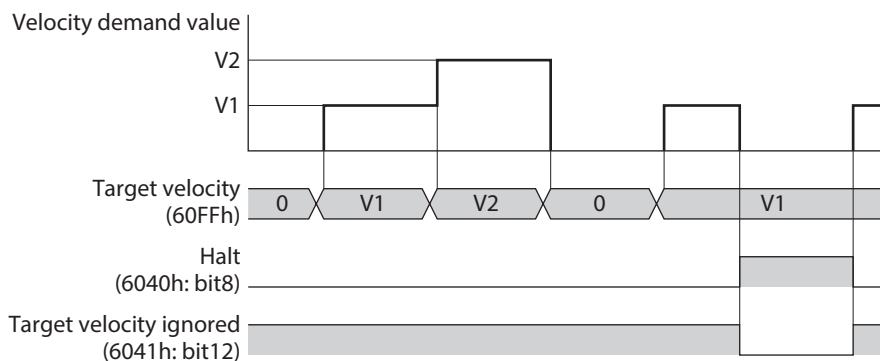

3-6 Profile velocity mode (PV)

The profile velocity mode operates in the internal profile of the driver. A path generation (profile generation) is performed in the driver. The speed, acceleration and others are set in the MainDevice.

Related object

Index	Sub	Name	Type	Access	PDO	Save	Range	Update
6040h	00h	Controlword	U16	RW	RxPDO	–	0000h to FFFFh (Initial value: 0000h)	A
6041h	00h	Statusword	U16	RO	TxPDO	–	–	–
6060h	00h	Modes of operation	INT8	RW	RxPDO	○	0 (Initial value), 1, 3, 6, 8, 9 (⇒ p.113)	B
6061h	00h	Modes of operation display	INT8	RO	TxPDO	–	–	–
606Bh	00h	Velocity demand value [Hz]	INT32	RO	TxPDO	–	–	–
606Ch	00h	Velocity actual value [Hz]	INT32	RO	TxPDO	–	–	–
607Fh	00h	Max profile velocity [Hz]	U32	RW	RxPDO	○	0 to 4,000,000 (Initial value: 1,000,000)	B
6083h	00h	Profile acceleration [step/s ²]	U32	RW	RxPDO	○	1 to 1,000,000,000 (Initial value: 300,000)	B
6084h	00h	Profile deceleration [step/s ²]	U32	RW	RxPDO	○	1 to 1,000,000,000 (Initial value: 300,000)	B
60FFh	00h	Target velocity [Hz]	INT32	RW	RxPDO	–	–4,000,000 to 4,000,000 (Initial value: 0)	B
4142h	00h	Starting speed [Hz]	INT32	RW	RxPDO	○	0 to 4,000,000 (Initial value: 5,000)	B

■ Controlword of the profile velocity mode

Bit15	Bit14	Bit13	Bit12	Bit11	Bit10	Bit9	Bit8
Manufacturer specific (ms)					Reserved	oms	Halt
–	–	Type		–		–	
Bit7	Bit6	Bit5	Bit4	Bit3	Bit2	Bit1	Bit0
Fault reset	Operation mode specific (oms)			Enable operation	Quick stop	Enable voltage	Switch on
	–	–	–				

Details of controlword

Bit	Name	Value	Description
13	Type	–	The operation mode of the profile velocity mode is selected. The operation mode changed is updated immediately. For details, refer to "Operation mode of the profile velocity mode" on p.130
12		–	
8	Halt	0	Operation allowed
		1	Stops operation. The stopping method is in accordance with the setting of the "Halt option code (605Dh)."

For the bit7 and bit3 to bit0, refer to "State transition of the drive state machine" on p.111.

■ Operation mode of the profile velocity mode

The operation mode of the profile velocity mode is set with the "Type (6040h: bit13, bit12)." The operation modes are as shown in the table.

Bit13	Bit12	Operation mode	Explanation
0	0	Continuous operation (Position control)	The motor is started running at the "Starting speed (4142h)" and accelerates until the "Target velocity (60FFh)" is reached. When the "Target velocity (60FFh)" is reached, operation is continued with the speed maintained. Operation is executed while the position deviation is monitored, so when a load exceeding the torque of the motor is applied, an alarm of overload or excessive position deviation is generated. If sudden position deviation occurs, for example, when a large load is removed, the motor accelerates suddenly or has overspeed to remove deviation.
0	1	Continuous operation (Speed control)	The motor is started running at the "Starting speed (4142h)" and accelerates until the "Target velocity (60FFh)" is reached. When the "Target velocity (60FFh)" is reached, operation is continued with the speed maintained. When a load exceeding the torque of the motor is applied, an alarm of overload is generated.
1	0	Continuous operation (Push-motion) *	The motor is started running at the "Starting speed (4142h)" and accelerates until the "Target velocity (60FFh)" is reached. When the "Target velocity (60FFh)" is reached, operation is continued with the speed maintained. When a mechanism installed to the motor presses against a load, pressure is continuously applied to the load.
1	1	Continuous operation (Torque control) *	Rectangular operation (drive without acceleration/deceleration time) of the motor is executed at the "Target velocity (60FFh)," and operation is continued with the speed maintained. When a mechanism installed to the motor presses against a load, pressure is continuously applied to the load.

- Note** * When continuous operation (push-motion) or continuous operation (torque control) is performed, note the following.
- When a mechanism installed to the motor pressed against a load, push-motion operation is performed while a position deviation of 2.7° generates. An alarm of overload may be generated if the operation is stopped in this state, so perform operation to return the actual position by 3.6° before push-motion operation is stopped.
 - Do not perform push-motion operation with geared motors and **DGII** Series. Doing so may cause damage to the motor or gear part.
 - When push-motion operation is stopped in a state where a load is pressed, set the "Operating current (4120h)" of the next operation to be executed, to a value in the "Push current (4121h)" or less. If a higher current value than the "Push current (4121h)" is set, the push current may increase when an operation is transited, causing an unexpected push force to apply.

■ Statusword of the profile velocity mode

Bit15	Bit14	Bit13	Bit12	Bit11	Bit10	Bit9	Bit8
Manufacturer specific		Operation mode specific		Internal limit active	Target reached	Remote	ms
TLC	–	–	Speed				–
Bit7	Bit6	Bit5	Bit4	Bit3	Bit2	Bit1	Bit0
Warning	Switch on disabled	Quick stop	Voltage enabled	Fault	Operation enabled	Switched on	Ready to switch on

Details of statusword

Bit	Name	Value	Description
15	TLC	0	A load does not reach the upper limit of the motor output torque.
		1	A load reached the upper limit of the motor output torque.
12	Speed	0	Internal speed command is other than 0.
		1	Internal speed command is 0.
11	Internal limit active	0	The function limitation by the internal limit is not in an active state.
		1	The function limitation by the internal limit became an active state. The value is 1 when any of the following internal limit function is activated. <ul style="list-style-type: none"> • Limit sensor (FW-LS/RV-LS) • Operation prohibition input (FW-BLK/RV-BLK) • Software limit • Mechanical limit
10	Target reached	0	<ul style="list-style-type: none"> • When the "Halt (6040h: bit8)" is 0: The internal feedback speed does not reach the "Target velocity (60FFh)." • When the "Halt (6040h: bit8)" is 1: During deceleration stop. (Internal speed command is other than 0.)
		1	<ul style="list-style-type: none"> • When the "Halt (6040h: bit8)" is 0: The internal feedback speed reached the "Target velocity (60FFh)." When the Halt is 0, the status of the VA output signal is output. The judgment level of the target speed reached can be set in the "VA mode selection (4718h)" and "VA detection speed range (4719h)." • When the "Halt (6040h: bit8)" is 1: Internal speed command is 0.
9	Remote	1	The value becomes 1 when the initialization is complete.
7	Warning	0	Information not present When the causes of information are cleared, the "Warning" is automatically cleared to 0.
		1	Information present.

For the bit6 to bit0, refer to "Status output of the drive state machine" on p.112.

■ Operation in the profile velocity mode

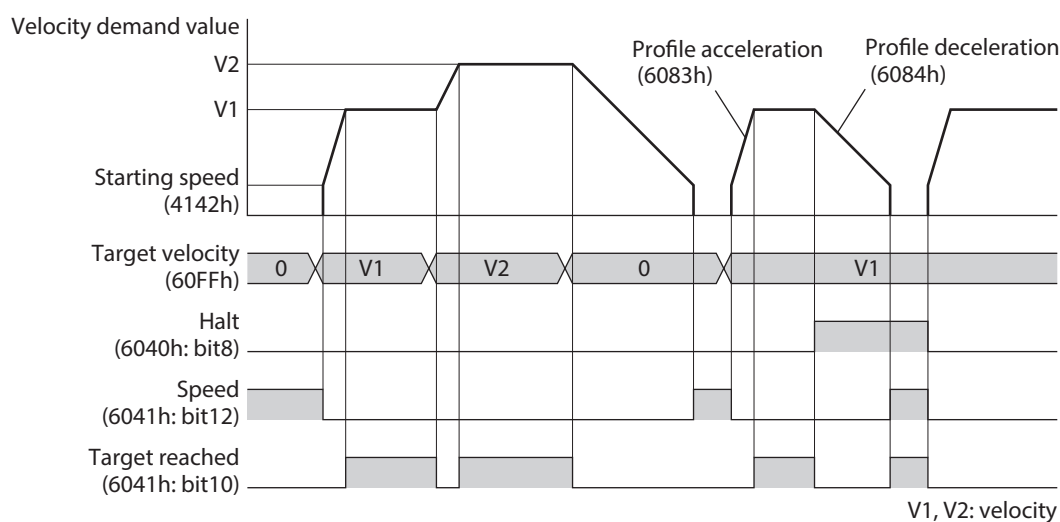

When the "Type (6040h: bit12, bit13)" is set to continuous operation (torque control), self-start operation (rectangular operation) at the "Target velocity (60FFh)" is performed.

3-7 Homing mode (HM)

The home is set in the homing mode. A path generation (profile generation) is performed in the driver. If return-to-home operation is performed, the position preset (P-PRESET) is executed when the operation is complete, and the home will be the value set in the "Home offset (607Ch)."

● **Related object**

Refer to "Selection of return-to-home method" on p.134.

■ **Before starting operation; When the motorized actuator is used**

For parameters of the **AZ** Series, the different values are stored in the ABZO sensor and driver. The values based on the product specifications are stored in the ABZO sensor. The values stored in the ABZO sensor cannot be changed because of the fixed value. Meantime, the values for the standard type (motor only) are stored in the driver parameters. In a state of the factory shipment, parameters (fixed value) stored in the ABZO sensor are used preferentially.

Since parameters stored in the driver are prioritized in the homing mode, change the setting according to the following steps.

1. Copy the ABZO information (fixed value) of the ABZO sensor to the driver.
Refer to the **AZ** Series OPERATING MANUAL Function Edition.
2. Change the "JOG/HOME/ZHOME operation setting (47F5h)" to "1: Manual setting."
3. Change the "Homing method (6098h)" to "-1: Return-to-home of our specifications."
4. Execute the "Write batch NV memory (40C9h)."
5. Turn on the control power supply of the driver again.
With these steps, the driver parameters will be prioritized.

■ **Controlword of the homing mode**

Bit15	Bit14	Bit13	Bit12	Bit11	Bit10	Bit9	Bit8
Manufacturer specific (ms)					Reserved	oms	Halt
-	-	-	-	-		-	
Bit7	Bit6	Bit5	Bit4	Bit3	Bit2	Bit1	Bit0
Fault reset	Operation mode specific (oms)			Enable operation	Quick stop	Enable voltage	Switch on
	-	-	Homing operation start				

Details of controlword

Bit	Name	Value	Description
8	Halt	0	Operation allowed
		1	Stops operation. The stopping method is in accordance with the setting of the "Halt option code (605Dh)."
4	Homing operation start	0 → 1	Start of return-to-home operation If the "Homing operation start" is set to 0 during return-to-home operation, the motor decelerates to a stop. When the state is any of the followings, the command is not received, and an operation does not start. <ul style="list-style-type: none"> • During operation • "Halt (6040h: bit8)" has been 1. • The STOP input is ON. • The drive state machine is other than "Operation enabled." • The motor is in a non-excitation state.

For the bit7 and bit3 to bit0, refer to "State transition of the drive state machine" on p.111.

■ Statusword of the homing mode

Bit15	Bit14	Bit13	Bit12	Bit11	Bit10	Bit9	Bit8
Manufacturer specific		Operation mode specific		Internal limit active	Target reached	Remote	ms
TLC	–	Homing error	Homing attained				–
Bit7	Bit6	Bit5	Bit4	Bit3	Bit2	Bit1	Bit0
Warning	Switch on disabled	Quick stop	Voltage enabled	Fault	Operation enabled	Switched on	Ready to switch on

● Details of statusword

Bit	Name	Value	Description
15	TLC	0	A load does not reach the upper limit of the motor output torque.
		1	A load reached the upper limit of the motor output torque.
13	Homing error	0/1	The status of the motor is output by combining the values in the "Homing error (6041h: bit13)," "Homing attained (6041h: bit12)" and "Target reached (6041h: bit 10)." For details, refer to table next.
12	Homing attained	0/1	The status of the motor is output by combining the values in the "Homing error (6041h: bit13)," "Homing attained (6041h: bit12)" and "Target reached (6041h: bit10)." For details, refer to table next.
11	Internal limit active	0	The function limitation by the internal limit is not in an active state.
		1	The function limitation by the internal limit became an active state. The value is 1 when any of the following internal limit function is activated. <ul style="list-style-type: none"> • Limit sensor (FW-LS/RV-LS) • Operation prohibition input (FW-BLK/RV-BLK) • Software limit • Mechanical limit
10	Target reached	0/1	The status of the motor is output by combining the values in the "Homing error (6041h: bit13)," "Homing attained (6041h: bit12)" and "Target reached (6041h: bit10)." For details, refer to table next.
9	Remote	1	The value becomes 1 when the initialization is complete.
7	Warning	0	Information not present When the causes of information are cleared, the "Warning" is automatically cleared to 0.
		1	Information present.

For the bit6 to bit0, refer to "Status output of the drive state machine" on p.112.

● Status output of motor

The status of the motor is output by combining the values in the "Homing error (bit13)," "Homing attained (bit12)" and "Target reached (bit10)."

Homing error (Bit13)	Homing attained (Bit12)	Target reached (Bit10)	Status
0	0	0	During operation of return-to-home operation
0	0	1	Return-to-home operation is interrupted, or it is not started.
0	1	0	– (Not generated)
0	1	1	Return-to-home operation was properly complete.
1	0	0	– (Not generated)
1	0	1	Interrupted since an alarm was generated during return-to-home operation.
1	1	0	Reserved
1	1	1	Reserved

■ Selection of return-to-home method

The return-to-home method is selected in the "Homing method (6098h)." The driver supports the following return-to-home methods.

Homing method	Description
17	Return-to-home by the limit sensor (FW-LS/RV-LS), Starts in the negative direction
18	Return-to-home by the limit sensor (FW-LS/RV-LS), Starts in the positive direction
24	Return-to-home by the home sensor (HOMES), Starts in the positive direction
28	Return-to-home by the home sensor (HOMES), Starts in the negative direction
35, 37 *	Home preset
-1	Return-to-home of our specifications

* 35 and 37 perform the same action.

● Related object

Index	Sub	Name	Type	Access	PDO	Save	Range	Update
607Ch	00h	Home offset [step]	INT32	RW	No	<input type="radio"/>	-2,147,483,648 to 2,147,483,647 (Initial value: 0)	A
6098h	00h	Homing method	INT8	RW	No	<input type="radio"/>	17, 18, 24 (Initial value), 28, 35, 37, -1 (⇔ "Selection of return-to-home method")	B
6099h	01h	Speed during search for switch [Hz]	U32	RW	No	<input type="radio"/>	1 to 4,000,000 (Initial value: 10,000)	B
	02h	Speed during search for zero [Hz]	U32	RW	No	<input type="radio"/>	1 to 10,000 (Initial value: 5,000)	B
609Ah	00h	Homing acceleration [step/sec ²]	U32	RW	No	<input type="radio"/>	1 to 1,000,000,000 (Initial value: 300,000)	B
415Fh	00h	JOG/HOME/ZHOME operating current [1=0.1 %]	INT16	RW	No	<input type="radio"/>	0 to 1,000 (Initial value: 1,000)	B
4163h	00h	(HOME) Starting speed [Hz]	INT32	RW	No	<input type="radio"/>	1 to 4,000,000 (Initial value: 5,000)	B
4169h	00h	(HOME) Backward steps in 2 sensor home-seeking [step]	INT32	RW	No	<input type="radio"/>	0 to 8,388,607 (Initial value: 5,000)	B
41C6h	00h	Preset position [step]	INT32	RW	No	<input type="radio"/>	-2,147,483,648 to 2,147,483,647 (Initial value: 0)	A

● Return-to-home operation of our specifications

Return-to-home mode of our specifications is applied when setting the "Homing method (6098h)" to -1.

Related object (our specifications)

Index	Sub	Name	Type	Access	PDO	Save	Range	Update
607Ch	00h	Home offset [step]	INT32	RW	No	<input type="radio"/>	-2,147,483,648 to 2,147,483,647 (Initial value: 0)	A
6099h	01h	Speed during search for switch [Hz]	U32	RW	No	<input type="radio"/>	1 to 4,000,000 (Initial value: 10,000)	B
	02h	Speed during search for zero [Hz]	U32	RW	No	<input type="radio"/>	1 to 10,000 (Initial value: 5,000)	B
609Ah	00h	Homing acceleration [step/sec ²]	U32	RW	No	<input type="radio"/>	1 to 1,000,000,000 (Initial value: 300,000)	B
415Fh	00h	JOG/HOME/ZHOME operating current [1=0.1 %]	INT16	RW	No	<input type="radio"/>	0 to 1,000 (Initial value: 1,000)	B
4160h	00h	(HOME) Home-seeking mode	U8	RW	No	<input type="radio"/>	0: 2-sensor 1: 3-sensor (Initial value) 2: One-way rotation 3: Push-motion	B
4161h	00h	(HOME) Starting direction	U8	RW	No	<input type="radio"/>	0: Negative side 1: Positive side (Initial value)	B
4163h	00h	(HOME) Starting speed [Hz]	INT32	RW	No	<input type="radio"/>	1 to 4,000,000 (Initial value: 5,000)	B
4166h	00h	(HOME) SLIT detection	U8	RW	No	<input type="radio"/>	0: Disable (Initial value) 1: Enable	B
4167h	00h	(HOME) TIM/ZSG signal detection	U8	RW	No	<input type="radio"/>	0: Disable (Initial value) 1: TIM 2: ZSG	B
4168h	00h	(HOME) Position offset [Hz]	INT32	RW	No	<input type="radio"/>	-2,147,483,647 to 2,147,483,647 (Initial value: 0)	B
4169h	00h	(HOME) Backward steps in 2 sensor home-seeking [step]	INT32	RW	No	<input type="radio"/>	0 to 8,388,607 (Initial value: 5,000)	B
416Ah	00h	(HOME) Operating amount in uni-directional home-seeking [step]	INT32	RW	No	<input type="radio"/>	0 to 8,388,607 (Initial value: 5,000)	B
416Bh	00h	(HOME) Operating current for push-home-seeking [1=0.1 %]	INT16	RW	No	<input type="radio"/>	0 to 1,000 (Initial value: 1,000)	B
416Ch	00h	(HOME) Backward steps after first entry in push-home-seeking [step]	INT32	RW	No	<input type="radio"/>	0 to 8,388,607 (Initial value: 0)	B
416Dh	00h	(HOME) Pushing time in push-home-seeking [ms]	U16	RW	No	<input type="radio"/>	0 to 65,535 (Initial value: 200)	B
416Eh	00h	(HOME) Backward steps in push-home-seeking [step]	INT32	RW	No	<input type="radio"/>	0 to 8,388,607 (Initial value: 5,000)	B
41C6h	00h	Preset position [step]	INT32	RW	No	<input type="radio"/>	-2,147,483,648 to 2,147,483,647 (Initial value: 0)	A

■ Operation of return-to-home mode of CiA402 drive profile

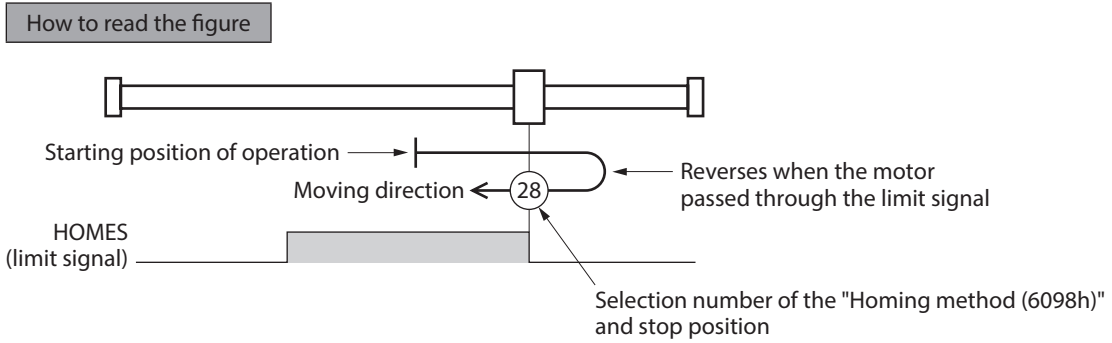

● Homing method: 24 [Return-to-home by the home sensor (HOMES), starts in the positive direction]

When the HOME sensor is detected, the motor rotates in the reverse direction and pulls out of the HOME sensor at the "(HOME) Starting speed (4163h)." After pulling out of the HOME sensor, the motor reverses once again, and continue to operate at the "Speed during search for zero (6099h-02h)." The motor stops when the ON edge of the HOME sensor is detected, and the position at which the motor stopped becomes the home.

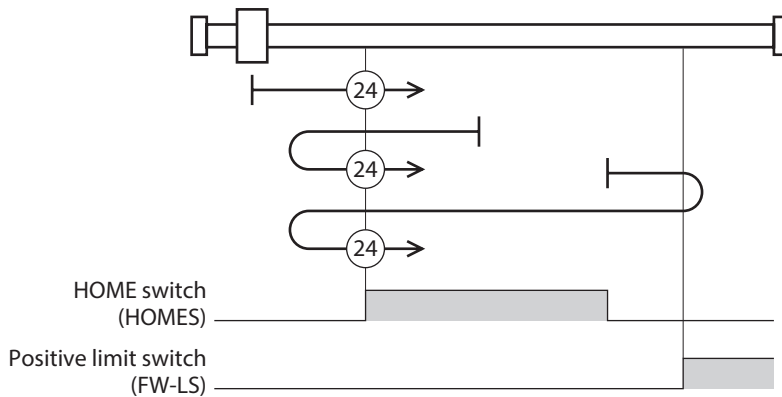

In the case of return-to-home operation of our specifications, the same operation is performed if the following data is set.

- (HOME) Home-seeking mode (4160h): 1 [3-sensor]
- (HOME) Starting direction (4161h): 1 [positive side]
- (HOME) SLIT detection (4166h): 0 [disable]
- (HOME) TIM/ZSG signal detection (4167h): 0 [disable]

● Homing method: 28 [Return-to-home by the home sensor (HOMES), starts in the negative direction]

When the HOME sensor is detected, the motor rotates in the reverse direction and pulls out of the HOME sensor at the "(HOME) Starting speed (4163h)." After pulling out of the HOME sensor, the motor reverses once again, and continue to operate at the "Speed during search for zero (6099h-02h)." The motor stops when the ON edge of the HOME sensor is detected, and the position at which the motor stopped becomes the home.

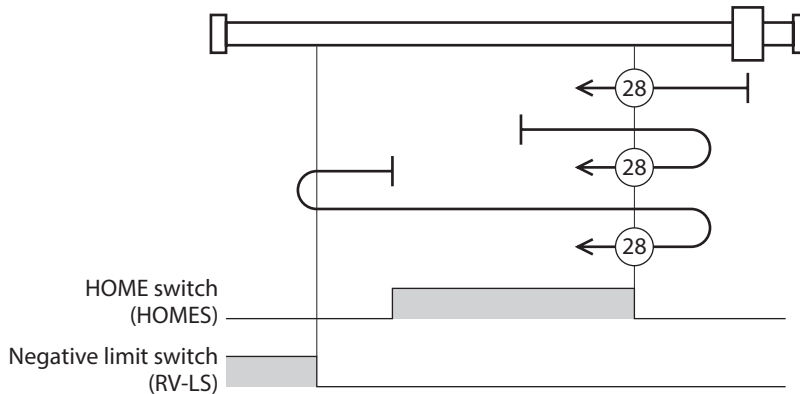

In the case of return-to-home operation of our specifications, the same operation is performed if the following data is set.

- (HOME) Home-seeking mode (4160h): 1 [3-sensor]
- (HOME) Starting direction (4161h): 0 [negative side]
- (HOME) SLIT detection (4166h): 0 [disable]
- (HOME) TIM/ZSG signal detection (4167h): 0 [disable]

- **Homing method: 17 [Return-to-home by the limit sensor (FW-LS/RV-LS), starts in the negative direction]**

After pulling out of the limit sensor, the motor rotates to stop according to the value set in the "(HOME) Backward steps in 2 sensor home-seeking (4169h)." The stop position will be the home.

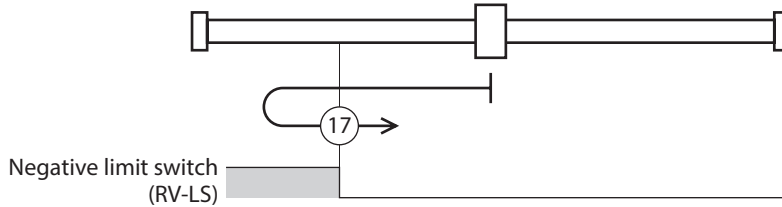

In the case of return-to-home operation of our specifications, the same operation is performed if the following data is set.

- (HOME) Home-seeking mode (4160h): 0 [2-sensor]
- (HOME) Starting direction (4161h): 0 [negative side]
- (HOME) SLIT detection (4166h): 0 [disable]
- (HOME) TIM/ZSG signal detection (4167h): 0 [disable]

- **Homing method: 18 [Return-to-home by the limit sensor (FW-LS/RV-LS), starts in the positive direction]**

After pulling out of the limit sensor, the motor rotates to stop according to the value set in the "(HOME) Backward steps in 2 sensor home-seeking (4169h)." The stop position will be the home.

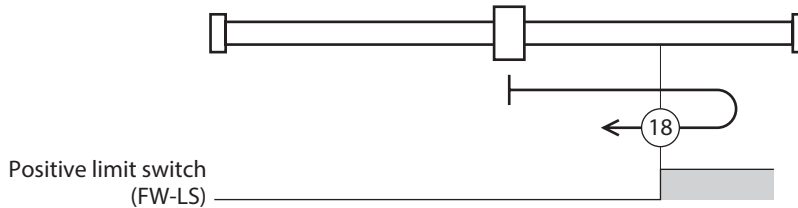

In the case of return-to-home operation of our specifications, the same operation is performed if the following data is set.

- (HOME) Home-seeking mode (4160h): 0 [2-sensor]
- (HOME) Starting direction (4161h): 1 [positive side]
- (HOME) SLIT detection (4166h): 0 [disable]
- (HOME) TIM/ZSG signal detection (4167h): 0 [disable]

- **Homing method: 35, Homing method: 37 (home preset)**

The present position will be the home. The home preset can be executed except when the drive state machine is in a state of "Operation enabled." It can also be executed even when the motor is in a non-excitation state.

■ Operation of the return-to-home mode of our specifications

● Return-to-home operation sequence of the 3-sensor mode

The motor operates at the "Speed during search for switch (6099h-01h)." When the limit sensor is detected during operation, the motor rotates in the reverse direction and pulls out of the limit sensor. When the ON edge of the HOME sensor is detected, operation is stopped. The position at which the motor stopped becomes the home.

Explanation of labels	<ul style="list-style-type: none"> ● VR: Speed during search for switch (6099h-01h) ● VS: (HOME) Starting speed (4163h) ● VL: Speed during search for zero (6099h-02h) ● - - -: Orbit when a home offset is set
-----------------------	---

Starting position of return-to-home operation	Starting direction of return-to-home operation: Positive side	Starting direction of return-to-home operation: Negative side
RV-LS		
FW-LS		
HOMES		
Between HOMES and RV-LS		
Between HOMES and FW-LS		

When the SLIT input, TIM signal, and ZSG signal are used concurrently

Even after return-to-home operation is complete, operation is continued until an external signal is detected. The return-to-home operation will be completed when the external signal is detected while the HOME sensor is being ON.

Explanation of labels	<ul style="list-style-type: none"> • VR: Speed during search for switch (6099h-01h) • VS: (HOME) Starting speed (4163h) • VL: Speed during search for zero (6099h-02h) • - - -: Orbit when a home offset is set
-----------------------	---

Home detection signal	Starting direction of return-to-home operation: Positive side	Starting direction of return-to-home operation: Negative side
SLIT input		
TIM signal or ZSG signal		
SLIT input and TIM signal or SLIT input and ZSG signal		

● **Return-to-home operation sequence of the 2-sensor mode**

The motor is operated in the "(HOME) Starting speed (4163h)." When the limit sensor is detected, the motor rotates in the reverse direction and pulls out of the limit sensor. After pulling out, the motor is operated according to the value of the "(HOME) Backward steps in 2 sensor home-seeking (4169h)" and stops. The position at which the motor stopped becomes the home.

Explanation of labels	<ul style="list-style-type: none"> ● VR: Speed during search for switch (6099h-01h) ● VS: (HOME) Starting speed (4163h) ● VL: Speed during search for zero (6099h-02h) ● - - -: Orbit when a home offset is set
-----------------------	---

Starting position of return-to-home operation	Starting direction of return-to-home operation: Positive side	Starting direction of return-to-home operation: Negative side
RV-LS		
FW-LS		
Between RV-LS and FW-LS		

* After pulling out of the limit sensor, the motor rotates to stop according to the value set in the "(HOME) Backward steps in 2 sensor home-seeking (4169h)."

When the SLIT input, TIM signal, and ZSG signal are used concurrently

Even after return-to-home operation is complete, operation is continued until an external signal is detected. If an external signal is detected, return-to-home operation is complete.

Explanation of labels	<ul style="list-style-type: none"> • VR: Speed during search for switch (6099h-01h) • VS: (HOME) Starting speed (4163h) • VL: Speed during search for zero (6099h-02h) • - - -: Orbit when a home offset is set
-----------------------	---

Home detection signal	Starting direction of return-to-home operation: Positive side	Starting direction of return-to-home operation: Negative side
SLIT input		
TIM signal or ZSG signal		
SLIT input and TIM signal or SLIT input and ZSG signal		

* After pulling out of the limit sensor, the motor rotates to stop according to the value set in the "(HOME) Backward steps in 2 sensor home-seeking (4169h)."

● **One-way rotation mode**

The motor is operated in the "Speed during search for switch (6099h-01h)." When the HOME sensor is detected, the motor decelerates to a stop and pulls out of the range of the HOME sensor at the "Speed during search for zero (6099h-02h)."

After pulling out, motor operates according to the value of "(HOME) Operating amount in uni-directional home-seeking (416Ah)," and stops. The position at which the motor stopped becomes the home.

Explanation of labels	<ul style="list-style-type: none"> ● VR: Speed during search for switch (6099h-01h) ● VS: (HOME) Starting speed (4163h) ● VL: Speed during search for zero (6099h-02h) ● - - -: Orbit when a home offset is set
-----------------------	---

Starting position of return-to-home operation	Starting direction of return-to-home operation: Positive side	Starting direction of return-to-home operation: Negative side
HOMES		
Other than HOMES		

* After pulling out of the HOME sensor, the motor rotates to stop according to the value set in the "(HOME) Operating amount in uni-directional home-seeking (416Ah)."

memo When the motor pulls out of the HOME sensor during deceleration stop after detection of the HOME sensor, an alarm of return-to-home error (alarm code 62h) is generated. Set the "Homing acceleration (609Ah)" so that the motor can stop in the range of the HOME sensor.

When the SLIT input, TIM signal, and ZSG signal are used concurrently

Even after return-to-home operation is complete, operation is continued until an external signal is detected. If an external signal is detected, return-to-home operation is complete.

Explanation of labels	<ul style="list-style-type: none"> • VR: Speed during search for switch (6099h-01h) • VS: (HOME) Starting speed (4163h) • VL: Speed during search for zero (6099h-02h) • - - -: Orbit when a home offset is set
-----------------------	---

Home detection signal	Starting direction of return-to-home operation: Positive side	Starting direction of return-to-home operation: Negative side
SLIT input		
TIM signal or ZSG signal		
SLIT input and TIM signal or SLIT input and ZSG signal		

* After pulling out of the HOME sensor, the motor rotates to stop according to the value set in the "(HOME) Operating amount in uni-directional home-seeking (416Ah)."

● **Push-motion mode**

The motor is operated in the "Speed during search for switch (6099h-01h)." When the motor presses the stopper or others installed in the mechanical end, it rotates in the reverse direction and stops after moving the value set in the "(HOME) Backward steps after first entry in push-home-seeking (416Ch)." Once again, the motor starts the operation toward the stopper, and it rotates in the reverse direction when pressing the stopper, and stops after moving the value set in the "(HOME) Backward steps in push-home-seeking (416Eh)."



Do not perform push-motion operation with geared motors and **DGII** Series. Doing so may cause damage to the motor or gear part.

Explanation of labels	<ul style="list-style-type: none"> ● VR: Speed during search for switch (6099h-01h) ● VS: (HOME) Starting speed (4163h) ● VL: Speed during search for zero (6099h-02h) ● - - -: Orbit when a home offset is set
-----------------------	---

Starting position of return-to-home operation	Starting direction of return-to-home operation: Positive side	Starting direction of return-to-home operation: Negative side
Between mechanical ends	<div style="display: flex; justify-content: space-around;"> <div style="text-align: center;">Reverse side mechanical end</div> <div style="text-align: center;">Forward side mechanical end</div> </div>	<div style="display: flex; justify-content: space-around;"> <div style="text-align: center;">Reverse side mechanical end</div> <div style="text-align: center;">Forward side mechanical end</div> </div>

- *1 The motor moves from the mechanical end according to the value set in the "(HOME) Backward steps after first entry in push-home-seeking (416Ch)" and stop.
- *2 The motor moves from the mechanical end according to the value set in the "(HOME) Backward steps in push-home-seeking (416Eh)" and stop.

When the SLIT input, TIM signal, and ZSG signal are used concurrently

Even after return-to-home operation is complete, operation is continued until an external signal is detected. If an external signal is detected, return-to-home operation is complete.

Explanation of labels	<ul style="list-style-type: none"> • VR: Speed during search for switch (6099h-01h) • VS: (HOME) Starting speed (4163h) • VL: Speed during search for zero (6099h-02h) • ---: Orbit when a home offset is set
-----------------------	---

Home detection signal	Starting direction of return-to-home operation: Positive side	Starting direction of return-to-home operation: Negative side
SLIT input	<p>Reverse side mechanical end Forward side mechanical end</p> <p>+VR +VS +VL -VL -VS -VR</p> <p>SLIT input ON OFF</p>	<p>Reverse side mechanical end Forward side mechanical end</p> <p>+VR +VS +VL -VL -VS -VR</p> <p>SLIT input ON OFF</p>
TIM signal or ZSG signal	<p>Reverse side mechanical end Forward side mechanical end</p> <p>+VR +VS +VL -VL -VS -VR</p> <p>TIM output ON (ZSG output) OFF</p>	<p>Reverse side mechanical end Forward side mechanical end</p> <p>+VR +VS +VL -VL -VS -VR</p> <p>TIM output ON (ZSG output) OFF</p>
SLIT input and TIM signal or SLIT input and ZSG signal	<p>Reverse side mechanical end Forward side mechanical end</p> <p>+VR +VS +VL -VL -VS -VR</p> <p>SLIT input ON OFF</p> <p>TIM output ON (ZSG output) OFF</p>	<p>Reverse side mechanical end Forward side mechanical end</p> <p>+VR +VS +VL -VL -VS -VR</p> <p>SLIT input ON OFF</p> <p>TIM output ON (ZSG output) OFF</p>

* The motor moves from the mechanical end according to the value set in the "(HOME) Backward steps in push-home-seeking (416Eh)" and stop.

4 Function

4-1 Touch probe

The touch probe is a function to set the external latch input signal (EXT1 input, EXT2input) or output signal (ZSG output, TIM output) as a trigger, and to latch the position for when the trigger is input. For the position to latch, either of the internal command position or feedback position can be selected.

The touch probe has the touch probe 1 and touch probe 2.

● Related object

Index	Sub	Name	Type	Access	PDO	Save	Range	Update
60B8h	00h	Touch probe function	U16	RW	RxPDO	–	0000h to FFFFh (Initial value: 0000h)	A
60B9h	00h	Touch probe status	U16	RO	TxPDO	–	–	–
60BAh	00h	Touch probe position 1 positive value [step]	INT32	RO	TxPDO	–	–	–
60BBh	00h	Touch probe position 1 negative value [step]	INT32	RO	TxPDO	–	–	–
60BCh	00h	Touch probe position 2 positive value [step]	INT32	RO	TxPDO	–	–	–
60BDh	00h	Touch probe position 2 negative value [step]	INT32	RO	TxPDO	–	–	–
44B0h	00h	Touch probe 1 latch position	U8	RW	No	–	0: Latches the feedback position (Initial value) 1: Latches the command position	A
44B1h	00h	Touch probe 2 latch position	U8	RW	No	–	0: Latches the feedback position (Initial value) 1: Latches the command position	A
44B2h	00h	Touch probe 1 TIM/ZSG signal select	U8	RW	No	–	0: Latch on the ZSG output (Initial value) 1: Latch on the TIM output	A
44B3h	00h	Touch probe 2 TIM/ZSG signal select	U8	RW	No	–	0: Latch on the ZSG output (Initial value) 1: Latch on the TIM output	A

● Related signal

Signal name	Description
EXT1 input	This is an external latch input signal for the touch probe 1.
EXT2 input	This is an external latch input signal for the touch probe 2.
ZSG output	This signal can be used in the touch probe 1 and touch probe 2.
TIM output	This signal is output once per 7.2° rotation of the motor output shaft. It can be used in the touch probe 1 and touch probe 2.

■ Details of touch probe function

The action of the touch probe is set in the "Touch probe function (60B8h)"

The action of the touch probe 1 is set in the lower 8 bits, and that of the touch probe 2 is set in the upper 8 bits.

Set the trigger condition using the Touch probe 1 trigger action/Touch probe 2 trigger action (Bit1/Bit9) and the Touch probe 1 trigger selection/Touch probe 2 trigger selection (Bit2/Bit10). After that, changing the Touch probe 1 permission/Touch probe 2 permission (Bit0/Bit8) from 0 to 1 latches according to the set trigger condition.

Be sure to change the Touch probe 1 permission/Touch probe 2 permission (Bit0/Bit8) back to 0 before changing the trigger condition. Changing the trigger condition while the Touch probe 1 permission/Touch probe 2 permission (Bit0/Bit8) remains 1 will not be enabled.

Bit	Name	Value	Definition
0	Touch probe 1 permission	0	Disables touch probe 1.
		1	Enables touch probe 1.
1	Touch probe 1 trigger action	0	First trigger action Latches only once on the first trigger.
		1	Continuous operation Latches every time a trigger is input.
2	Touch probe 1 trigger selection	0	Sets the external latch input EXT1 as a trigger.
		1	Sets the ZSG output or TIM output as a trigger.
3	Reserved	0	Reserved
4	Touch probe 1 positive value action	0	Disables the latch function at the positive value of a trigger.
		1	Enables the latch function at the positive value of a trigger.
5	Touch probe 1 negative value action	0	Disables the latch function at the negative value of a trigger.
		1	Enables the latch function at the negative value of a trigger.
6	Reserved	0	Reserved
7	Reserved	0	Reserved
8	Touch probe 2 permission	0	Disables touch probe 2.
		1	Enables touch probe 2.
9	Touch probe 2 trigger action	0	First trigger action Latches only once on the first trigger.
		1	Continuous operation Latches every time a trigger is input.
10	Touch probe 2 trigger selection	0	Sets the external latch input EXT2 as a trigger.
		1	Sets the ZSG output or TIM output as a trigger.
11	Reserved	0	Reserved
12	Touch probe 2 positive value action	0	Disables the latch function at the positive value of a trigger.
		1	Enables the latch function at the positive value of a trigger.
13	Touch probe 2 negative value action	0	Disables the latch function at the negative value of a trigger.
		1	Enables the latch function at the negative value of a trigger.
14	Reserved	0	Reserved
15	Reserved	0	Reserved

■ Details of touch probe status

The status of the touch probe is output by the "Touch probe status (60B9h)."

The status of the touch probe 1 is output by the lower 8 bits, and that of the touch probe 2 is output by the upper 8 bits.

Bit	Name	Value	Definition
0	Touch probe 1 permission status	0	Touch probe 1 is disabled.
		1	Touch probe 1 is enabled.
1	Touch probe 1 positive value latch	0	Has not latch on the positive value of the touch probe 1.
		1	Latched on the positive value of the touch probe 1.
2	Touch probe 1 negative value latch	0	Has not latch on the negative value of the touch probe 1.
		1	Latched on the negative value of the touch probe 1.
3 to 7	Reserved	0	Reserved
8	Touch probe 2 permission status	0	Touch probe 2 is disabled.
		1	Touch probe 2 is enabled.
9	Touch probe 2 positive value latch	0	Has not latch on the positive value of the touch probe 2.
		1	Latched on the positive value of the touch probe 2.
10	Touch probe 2 negative value latch	0	Has not latch on the negative value of the touch probe 2.
		1	Latched on the negative value of the touch probe 2.
11 to 15	Reserved	0	Reserved

■ Trigger and latch position

A signal that is set as a trigger is selected by the "Trigger selection (bit2/bit10)" of the "Touch probe function (60B8h)."

The ZSG output and TIM output can be selected by the "Touch probe TIM/ZSG signal select (44B2h/44B3h)."

The latch position varies depending on the signal that was set as the trigger. When the external latch input (EXT1 input, EXT2 input) is set as the trigger, the latch position can be set to either of the feedback position (actual position) or internal command position.

Signal name	Latch position
External latch input	Feedback position (actual position) or internal command position. Select by the "Touch probe latch position (44B0h/44B1h)"
ZSG output	Feedback position
TIM output	Internal command position

Related object

Index	Sub	Object name	Initial value	Description
44B0h	00h	Touch probe 1 latch position	0	0: Latches the feedback position 1: Latches the command position
44B1h	00h	Touch probe 2 latch position	0	
44B2h	00h	Touch probe 1 TIM/ZSG signal select	0	0: Latch on the ZSG output 1: Latch on the TIM output
44B3h	00h	Touch probe 2 TIM/ZSG signal select	0	

■ **Operation sequence of the touch probe**

The operation examples of touch probe 1 are shown below.

● **If the trigger action is "First trigger action (60B8h: bit1 is 0)"**

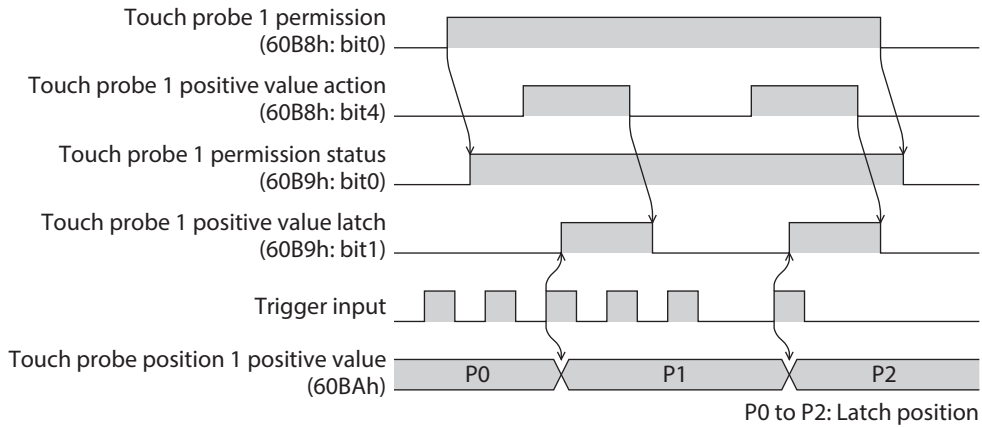

● **If the trigger action is "Continuous operation (60B8h: bit1 is 1)"**

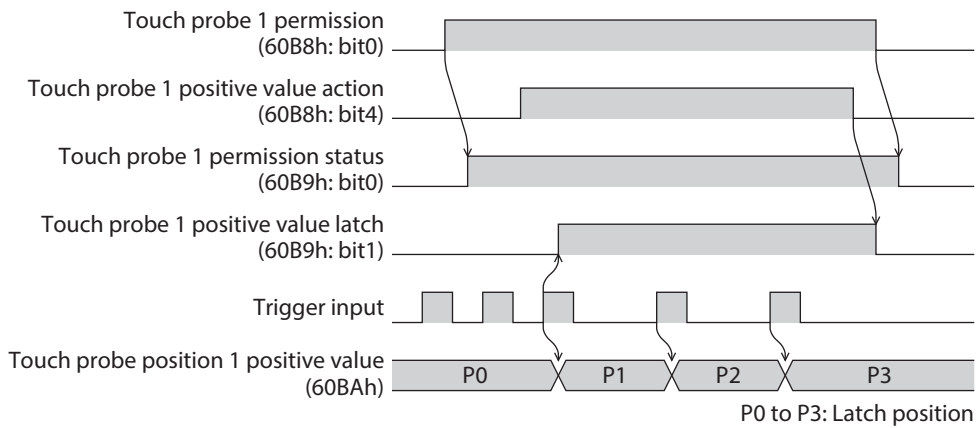

4-2 Resolution

When the "Gear ratio (6091h)" is set, the resolution per one rotation of the motor output shaft can be set.

- Resolution of the motor output shaft = $10,000 \times \text{"Electronic gear B (6091h-02h)"} / \text{"Electronic gear A (6091h-01h)"}$
- Factory setting: 10,000 P/R
- Setting range: 100 to 100,000 P/R

Related object

Index	Sub	Name	Type	Access	PDO	Save	Range	Update
6091h	00h	Number of entries	U8	RO	No	–	2	–
	01h	Electronic gear A	U32	RW	No	○	1 to 65,535 (Initial value: 1)	C
	02h	Electronic gear B	U32	RW	No	○	1 to 65,535 (Initial value: 1)	C



- If the value out of the setting range is set, the information of electronic gear setting error is generated (information code 2000h). If the control power supply is turned on again or configuration is executed while the information of electronic gear setting error is present, an alarm of electronic gear setting error is generated (alarm code 71h).
- If the resolution was changed after executing preset with the "Home offset (607Ch)" other than "0," execute preset again. When the "Home offset (607Ch)" is "0," it is no need to execute preset again even if the resolution is changed. (The present position is calculated automatically.)
- When the TIM output is used in return-to-home operation or others, set the resolution to be an integral multiple of 50.

■ Note when setting a resolution that exceeds 10,000 P/R

Consider the following when setting a resolution that exceeds 10,000 P/R.

● Operating speed

The setting range of the object to set the operating speed is 1 to 4,000,000 Hz.

Sets the resolution according to the operating speed actually desired.

Example: When the resolution is 100,000 P/R and the object to set the operating speed is 4,000,000 Hz, the motor operating speed is 2,400 r/min.

Also, in the profile position mode (PP) and the profile velocity mode (PV), the operating speed is limited at the Max profile velocity (607Fh). The initial value for the Max profile velocity (607Fh) is 1,000,000 Hz. When a value higher than 1,000,000 Hz is set to the object to set the operating speed, also set the Max profile velocity (607Fh).

● TIM output

If the resolution is set to a value that exceeds 10,000 P/R, the signal will not be output properly. Therefore, do not use the TIM output.

● Phase A (ASG) output, phase B (BSG) output

If the resolution is set to a value that exceeds 10,000 P/R, the signal will not be output properly. Therefore, use the **MEXE02** to set the "Differential output mode selection" parameter to "–1: Not output" so that the signal is not output. The "Differential output mode selection" parameter cannot be set via EtherCAT communication.

Related parameter

MEXE02 code	Name	Setting range	Initial value
EXT-IN & VIR-IN & USR-OUT function (Extend)	Differential output mode selection	–1: Not output 0: Phase A / Phase B output	0

4-3 Wrap function

The wrap function is a function to automatically preset the position information of the current position when the number of revolutions of the motor output shaft exceeds the set range. Setting of wrap offset allows you to limit the operation area of the equipment and control the index table with coordinates on the positive and negative sides.

Related object

Index	Sub	Name	Type	Access	PDO	Save	Range	Update
41C7h	00h	Wrap setting	U8	RW	No	<input type="radio"/>	0: Disable 1: Enable (Initial value)	C
41C9h	00h	Initial coordinate generation & wrap setting range [1=0.1 rev]	INT32	RW	No	<input type="radio"/>	5 to 655,360 (Initial value: 10)	C
41CBh	00h	Initial coordinate generation & wrap range offset ratio [1=0.01 %]	U16	RW	No	<input type="radio"/>	0 to 10,000 (Initial value: 5,000)	C
41CCh	00h	Initial coordinate generation & wrap range offset value [step]	INT32	RW	No	<input type="radio"/>	-536,870,912 to 536,870,911 (Initial value: 0)	C

4-4 Operating current and stop current

Set the base current rate (%) for the operating current and stop current by the "Base current (4126h)."

- Operating current = Maximum output current × "Base current (4126h)" × "Operating current (4120h)"
- Stop current = Maximum output current × "Base current (4126h)" × "Stop current (4128h)"
- Push current = Maximum output current × "Base current (4126h)" × "Push current (4121h)"



If the base current is set, the maximum output current of the driver can be changed. If the load is small and there is an ample allowance for torque, the motor temperature rise can be suppressed by setting a lower base current. However, excessively low base current may cause a problem in starting the motor or holding the load in position. Do not reduce the base current any more than is necessary.

Related object

Index	Sub	Name	Type	Access	PDO	Save	Range	Update
4120h	00h	Operating current [1=0.1 %]	INT16	RW	RxPDO	<input type="radio"/>	0 to 1,000 (Initial value: 1,000)	A *
4121h	00h	Push current [1=0.1 %]	INT16	RW	RxPDO	<input type="radio"/>	0 to 1,000 (Initial value: 200)	A *
4126h	00h	Base current [1=0.1 %]	INT16	RW	RxPDO	<input type="radio"/>	0 to 1,000 (Initial value: 1,000)	A
4128h	00h	Stop current [1=0.1 %]	INT16	RW	RxPDO	<input type="radio"/>	0 to 1,000 (Initial value: 500)	A
415Fh	00h	JOG/HOME/ZHOME operating current [1=0.1 %]	INT16	RW	No	<input type="radio"/>	0 to 1,000 (Initial value: 1,000)	B
416Bh	00h	(HOME) Operating current for push-home-seeking [1=0.1 %]	INT16	RW	No	<input type="radio"/>	0 to 1,000 (Initial value: 1,000)	B

* With the profile position mode, it will be update at start of operation.

4-5 Maintenance commands

Resetting an alarm, the position preset (P-PRESET), batch processing for the non-volatile memory, and others are performed.



The maintenance commands include processing in which the memory is operated, such as non-volatile memory batch processing and position preset (P-PRESET). Be careful not to execute them unnecessarily in succession.

Related object

Index	Sub	Name	Description
40C0h	00h	Alarm reset	Resets the alarm that is present. Some alarms cannot be reset.
40C2h	00h	Clear alarm history	Clears alarm history.
40C5h	00h	P-PRESET execution	Presets the command position.
40C6h	00h	Configuration	Executes the parameter recalculation and the setup.
40C8h	00h	Read batch NV memory	Reads the parameters saved in the non-volatile memory to the RAM. All parameters saved in the RAM are overwritten.
40C9h	00h	Write batch NV memory	Writes the parameters saved in the RAM to the non-volatile memory. The non-volatile memory can be rewritten approximately 100,000 times.
40CAh	00h	All data initialization	Resets the parameters saved in the non-volatile memory to their initial values.
40CBh	00h	Read from backup	Reads all the data from the backup area.
40CCh	00h	Write to backup	Writes all the data to the backup area.
40CDh	00h	Clear latch information	Clears the cumulative load. This is used when the "Cumulative load value auto clear (41B3h)" is set to "0: Disable."
40CFh	00h	Clear tripmeter	Clears the tripmeter.
40D0h	00h	Execute ETO-CLR input	Puts the motor in a state where it can be excited after the power removal function is released.
40D1h	00h	ZSG-PRESET	Resets the position of the Z-phase.
40D2h	00h	Clear ZSG-PRESET	Clears the position data of the Z-phase reset by the "ZSG-PRESET (40D1h)" command.
40D3h	00h	Clear information	Clears information.
40D4h	00h	Clear information history	Clears information history.

■ How to execute maintenance commands

The following two methods are available to execute maintenance commands. Use them selectively in accordance with the intended use.

● Writing 1 to data (recommended)

When data is changed from 0 to 1 after 1 is written to it, the command is executed.

To execute the same command again, restore the data to 0 and then write 1. It is safe, because the command is not executed in succession even if 1 is written from the MainDevice continuously.

● Writing 2 to data

When 2 is written to data, the command is executed. After execution, the data is restored to 1 automatically. Data does not need to restore to 1, and it can be written consecutively.

If commands which take time to write to the non-volatile memory such as "Write batch NV memory (40C9h)" are executed consecutively, increase the length of the intervals between commands.

■ Configuration

Configuration can be executed when all of the following conditions are satisfied:

- An alarm is not present.
- The motor is not operating.
- I/O test, remote operation and downloading are not executed with the **MEXE02**.

The following table shows the driver status before and after executing the configuration.

Item	Configuration is ready to execute	Configuration is being executed	After execution of configuration
PWR/ALM LED	Green lit	Green and red blink twice simultaneously *	Depends on the driver condition.
Electromagnetic brake	Hold/release	Hold	
Motor excitation	Excitation/non-excitation	Non-excitation	
Output signal	Enable	Disable	Enable
Input signal	Enable	Disable	Enable

* Green and red colors may overlap and it may be visible to orange.



The correct monitor value may not be returned even if monitoring is executed during configuration.

4-6 Assignment of I/O function

This section explains the assignment of I/O functions and internal I/O status.

■ Assignment to input terminals

Input signals can be assigned to the input terminals IN0 to IN5. For input signals that can be assigned, refer to p.159.

Related object

Index	Sub	Name	Type	Access	PDO	Save	Range	Update
4840h	00h	DIN0 input function	U8	RW	No	○	0 to 127 [Initial value: 30 (HOMES)]	C
4841h	00h	DIN1 input function	U8	RW	No	○	0 to 127 [Initial value: 1 (FREE)]	C
4842h	00h	DIN2 input function	U8	RW	No	○	0 to 127 [Initial value: 12 (ETO-CLR)]	C
4843h	00h	DIN3 input function	U8	RW	No	○	0 to 127 [Initial value: 104 (EXT1)]	C
4844h	00h	DIN4 input function	U8	RW	No	○	0 to 127 [Initial value: 28 (FW-LS)]	C
4845h	00h	DIN5 input function	U8	RW	No	○	0 to 127 [Initial value: 29 (RV-LS)]	C

■ **Assignment to the output terminals**

Output signals can be assigned to the output terminals OUT0 to OUT5. For output signals that can be assigned, refer to p.160.

Related object

Index	Sub	Name	Type	Access	PDO	Save	Range	Update
4860h	00h	DOUT0 (Normal) output function	U8	RW	No	○	0 to 255 [Initial value: 144 (HOME-END)]	C
4861h	00h	DOUT1 (Normal) output function	U8	RW	No	○	0 to 255 [Initial value: 137 (ETO-MON)]	C
4862h	00h	DOUT2 (Normal) output function	U8	RW	No	○	0 to 255 [Initial value: 133 (PLS-RDY)]	C
4863h	00h	DOUT3 (Normal) output function	U8	RW	No	○	0 to 255 [Initial value: 142 (CRNT)]	C
4864h	00h	DOUT4 (Normal) output function	U8	RW	No	○	0 to 255 [Initial value: 134 (MOVE)]	C
4865h	00h	DOUT5 (Normal) output function	U8	RW	No	○	0 to 255 [Initial value: 130 (ALM-B)]	C

■ **Direct I/O**

The status of the direct I/O can be checked using the "Direct I/O (406Ah)." Bit arrangements are as follows.

Bit31	Bit30	Bit29	Bit28	Bit27	Bit26	Bit25	Bit24
BSG	ASG	–	–	–	–	–	–
Bit23	Bit22	Bit21	Bit20	Bit19	Bit18	Bit17	Bit16
–	–	OUT5	OUT4	OUT3	OUT2	OUT1	OUT0
Bit15	Bit14	Bit13	Bit12	Bit11	Bit10	Bit9	Bit8
VR-IN3	VR-IN2	VR-IN1	VR-IN0	–	EXT-IN	–	–
Bit7	Bit6	Bit5	Bit4	Bit3	Bit2	Bit1	Bit0
–	–	IN5	IN4	IN3	IN2	IN1	IN0

Related object

Index	Sub	Name	Type	Access	PDO	Save	Range	Update
406Ah	00h	Direct I/O	U32	RO	TxPDO	–	–	–

■ I/O status

The status of the I/O inside the driver can be monitored using the I/O status. Bit arrangements of the internal I/O are as follows.

Driver object	Description							
I/O status 1 (40B8h)	Bit31	Bit30	Bit29	Bit28	Bit27	Bit26	Bit25	Bit24
	SLIT	HOMES	RV-LS	FW-LS	RV-BLK	FW-BLK	–	–
	Bit23	Bit22	Bit21	Bit20	Bit19	Bit18	Bit17	Bit16
	SPD-LMT	CRNT-LMT	T-MODE	PLS-DIS	PLS-XMODE	CCM	–	HMI
	Bit15	Bit14	Bit13	Bit12	Bit11	Bit10	Bit9	Bit8
	–	INFO-CLR	LAT-CLR	ETO-CLR	–	–	P-PRESET	ALM-RST
	Bit7	Bit6	Bit5	Bit4	Bit3	Bit2	Bit1	Bit0
–	–	STOP	–	CLR	–	FREE	Not used	
I/O status 2 (40B9h)	Bit31	Bit30	Bit29	Bit28	Bit27	Bit26	Bit25	Bit24
	–	–	–	–	–	–	–	–
	Bit23	Bit22	Bit21	Bit20	Bit19	Bit18	Bit17	Bit16
	–	–	–	–	–	–	–	–
	Bit15	Bit14	Bit13	Bit12	Bit11	Bit10	Bit9	Bit8
	–	–	–	–	–	–	–	–
	Bit7	Bit6	Bit5	Bit4	Bit3	Bit2	Bit1	Bit0
–	–	–	–	–	–	–	–	
I/O status 3 (40BAh)	Bit31	Bit30	Bit29	Bit28	Bit27	Bit26	Bit25	Bit24
	R15	R14	R13	R12	R11	R10	R9	R8
	Bit23	Bit22	Bit21	Bit20	Bit19	Bit18	Bit17	Bit16
	R7	R6	R5	R4	R3	R2	R1	R0
	Bit15	Bit14	Bit13	Bit12	Bit11	Bit10	Bit9	Bit8
	–	–	–	–	–	–	–	–
	Bit7	Bit6	Bit5	Bit4	Bit3	Bit2	Bit1	Bit0
–	–	–	–	–	–	–	–	
I/O status 4 (40BBh)	Bit31	Bit30	Bit29	Bit28	Bit27	Bit26	Bit25	Bit24
	–	–	–	–	–	–	–	–
	Bit23	Bit22	Bit21	Bit20	Bit19	Bit18	Bit17	Bit16
	–	–	–	–	–	–	–	–
	Bit15	Bit14	Bit13	Bit12	Bit11	Bit10	Bit9	Bit8
	–	–	–	–	–	–	EXT2	EXT1
	Bit7	Bit6	Bit5	Bit4	Bit3	Bit2	Bit1	Bit0
–	–	–	–	–	–	–	CON	
I/O status 5 (40BCh)	Bit31	Bit30	Bit29	Bit28	Bit27	Bit26	Bit25	Bit24
	–	–	TIM	RND-ZERO	ZSG	RV-SLS	FW-SLS	RND-OVF
	Bit23	Bit22	Bit21	Bit20	Bit19	Bit18	Bit17	Bit16
	ORGN-STLD	PRST-STLD	PRST-DIS	–	–	–	ABSPEN	HOME-END
	Bit15	Bit14	Bit13	Bit12	Bit11	Bit10	Bit9	Bit8
	AUTO-CD	CRNT	VA	TLC	–	IN-POS	ETO-MON	SYS-BSY
	Bit7	Bit6	Bit5	Bit4	Bit3	Bit2	Bit1	Bit0
INFO	MOVE	PLS-RDY	READY	SYS-RDY	ALM-B	ALM-A	CONST-OFF	

Driver object	Description							
	Bit31	Bit30	Bit29	Bit28	Bit27	Bit26	Bit25	Bit24
I/O status 6 (40BDh)	–	–	–	–	–	–	–	–
	Bit23	Bit22	Bit21	Bit20	Bit19	Bit18	Bit17	Bit16
	–	–	USR-OUT1	USR-OUT0	–	–	–	–
	Bit15	Bit14	Bit13	Bit12	Bit11	Bit10	Bit9	Bit8
	–	–	HWTAIN-MON	EDM-MON	–	RG	MBC	MPS
	Bit7	Bit6	Bit5	Bit4	Bit3	Bit2	Bit1	Bit0
	AREA7	AREA6	AREA5	AREA4	AREA3	AREA2	AREA1	AREA0
I/O status 7 (40BEh)	Bit31	Bit30	Bit29	Bit28	Bit27	Bit26	Bit25	Bit24
	–	–	–	–	–	–	–	–
	Bit23	Bit22	Bit21	Bit20	Bit19	Bit18	Bit17	Bit16
	–	–	–	–	–	–	–	–
	Bit15	Bit14	Bit13	Bit12	Bit11	Bit10	Bit9	Bit8
	–	–	DCMD-FULL	DCMD-RDY	PLS-LOST	–	–	–
	Bit7	Bit6	Bit5	Bit4	Bit3	Bit2	Bit1	Bit0
–	–	–	OPE-BSY	–	–	SPD-LMTD	CRNT-LMTD	
I/O status 8 (40BFh)	Bit31	Bit30	Bit29	Bit28	Bit27	Bit26	Bit25	Bit24
	INFO-RBT	INFO-CFG	INFO-IOTEST	INFO-DSLMTD	–	–	–	–
	Bit23	Bit22	Bit21	Bit20	Bit19	Bit18	Bit17	Bit16
	–	–	INFO-ODO	INFO-TRIP	INFO-CULD1	INFO-CULD0	INFO-RV-OT	INFO-FW-OT
	Bit15	Bit14	Bit13	Bit12	Bit11	Bit10	Bit9	Bit8
	–	INFO-RND-E	INFO-EGR-E	–	INFO-PR-REQ	INFO-ZHOME	INFO-START	INFO-SPD
	Bit7	Bit6	Bit5	Bit4	Bit3	Bit2	Bit1	Bit0
–	INFO-OLTIME	INFO-UVOLT	INFO-OVOLT	INFO-MTRTMP	INFO-DRVTMP	INFO-POSERR	INFO-USRIO	

Related object

Index	Sub	Name	Type	Access	PDO	Save	Range	Update
40B8h	00h	I/O status 1	U32	RO	TxPDO	–	–	–
40B9h	00h	I/O status 2	U32	RO	TxPDO	–	–	–
40BAh	00h	I/O status 3	U32	RO	TxPDO	–	–	–
40BBh	00h	I/O status 4	U32	RO	TxPDO	–	–	–
40BCh	00h	I/O status 5	U32	RO	TxPDO	–	–	–
40BDh	00h	I/O status 6	U32	RO	TxPDO	–	–	–
40BEh	00h	I/O status 7	U32	RO	TxPDO	–	–	–
40BFh	00h	I/O status 8	U32	RO	TxPDO	–	–	–

■ Driver input command

The "Driver input command (403Eh)" is an input command from the MainDevice to the driver. Bit arrangements are as follows.

Bit0 to bit15 are assigned to the R-IN0 to R-IN15.

(): Initial value

Bit15	Bit14	Bit13	Bit12	Bit11	Bit10	Bit9	Bit8
R-IN15 (not used)	R-IN14 (not used)	R-IN13 (not used)	R-IN12 (not used)	R-IN11 (not used)	R-IN10 (not used)	R-IN9 (not used)	R-IN8 (not used)
Bit7	Bit6	Bit5	Bit4	Bit3	Bit2	Bit1	Bit0
R-IN7 (not used)	R-IN6 (not used)	R-IN5 (not used)	R-IN4 (not used)	R-IN3 (not used)	R-IN2 (not used)	R-IN1 (not used)	R-IN0 (not used)

Related object

For input signals that can be assigned, refer to p.159.

Index	Sub	Name	Type	Access	PDO	Save	Range	Update
4900h	00h	R-IN0 input function	U8	RW	No	○	0 to 127 [Initial value: 0 (not used)]	C
4901h	00h	R-IN1 input function	U8	RW	No	○	0 to 127 [Initial value: 0 (not used)]	C
4902h	00h	R-IN2 input function	U8	RW	No	○	0 to 127 [Initial value: 0 (not used)]	C
4903h	00h	R-IN3 input function	U8	RW	No	○	0 to 127 [Initial value: 0 (not used)]	C
4904h	00h	R-IN4 input function	U8	RW	No	○	0 to 127 [Initial value: 0 (not used)]	C
4905h	00h	R-IN5 input function	U8	RW	No	○	0 to 127 [Initial value: 0 (not used)]	C
4906h	00h	R-IN6 input function	U8	RW	No	○	0 to 127 [Initial value: 0 (not used)]	C
4907h	00h	R-IN7 input function	U8	RW	No	○	0 to 127 [Initial value: 0 (not used)]	C
4908h	00h	R-IN8 input function	U8	RW	No	○	0 to 127 [Initial value: 0 (not used)]	C
4909h	00h	R-IN9 input function	U8	RW	No	○	0 to 127 [Initial value: 0 (not used)]	C
490Ah	00h	R-IN10 input function	U8	RW	No	○	0 to 127 [Initial value: 0 (not used)]	C
490Bh	00h	R-IN11 input function	U8	RW	No	○	0 to 127 [Initial value: 0 (not used)]	C
490Ch	00h	R-IN12 input function	U8	RW	No	○	0 to 127 [Initial value: 0 (not used)]	C
490Dh	00h	R-IN13 input function	U8	RW	No	○	0 to 127 [Initial value: 0 (not used)]	C
490Eh	00h	R-IN14 input function	U8	RW	No	○	0 to 127 [Initial value: 0 (not used)]	C
490Fh	00h	R-IN15 input function	U8	RW	No	○	0 to 127 [Initial value: 0 (not used)]	C

■ Driver output status

The status of the R-OUT0 to R-OUT15 can be checked using the "Driver output status (403Fh)." Bit arrangements are as follows.

(): Initial value

Bit15	Bit14	Bit13	Bit12	Bit11	Bit10	Bit9	Bit8
R-OUT15 (TLC)	R-OUT14 (IN-POS)	R-OUT13 (MOVE)	R-OUT12 (TIM)	R-OUT11 (AREA2)	R-OUT10 (AREA1)	R-OUT9 (AREA0)	R-OUT8 (SYS-BSY)
Bit7	Bit6	Bit5	Bit4	Bit3	Bit2	Bit1	Bit0
R-OUT7 (ALM-A)	R-OUT6 (INFO)	R-OUT5 (DCMD-RDY)	R-OUT4 (HOME-END)	R-OUT3 (not used)	R-OUT2 (ZSG)	R-OUT1 (RV-LS_R)	R-OUT0 (FW-LS_R)

Related object

For output signals that can be assigned, refer to p.160.

Index	Sub	Name	Type	Access	PDO	Save	Range	Update
4910h	00h	R-OUT0 output function	U8	RW	No	○	0 to 255 [Initial value: 28 (FW-LS_R)]	C
4911h	00h	R-OUT1 output function	U8	RW	No	○	0 to 255 [Initial value: 29 (RV-LS_R)]	C
4912h	00h	R-OUT2 output function	U8	RW	No	○	0 to 255 [Initial value: 155 (ZSG)]	C
4913h	00h	R-OUT3 output function	U8	RW	No	○	0 to 255 [Initial value: 0 (not used)]	C
4914h	00h	R-OUT4 output function	U8	RW	No	○	0 to 255 [Initial value: 144 (HOME-END)]	C
4915h	00h	R-OUT5 output function	U8	RW	No	○	0 to 255 [Initial value: 204 (DCMD-RDY)]	C
4916h	00h	R-OUT6 output function	U8	RW	No	○	0 to 255 [Initial value: 135 (INFO)]	C
4917h	00h	R-OUT7 output function	U8	RW	No	○	0 to 255 [Initial value: 129 (ALM-A)]	C
4918h	00h	R-OUT8 output function	U8	RW	No	○	0 to 255 [Initial value: 136 (SYS-BSY)]	C
4919h	00h	R-OUT9 output function	U8	RW	No	○	0 to 255 [Initial value: 160 (AREA0)]	C
491Ah	00h	R-OUT10 output function	U8	RW	No	○	0 to 255 [Initial value: 161 (AREA1)]	C
491Bh	00h	R-OUT11 output function	U8	RW	No	○	0 to 255 [Initial value: 162 (AREA2)]	C
491Ch	00h	R-OUT12 output function	U8	RW	No	○	0 to 255 [Initial value: 157 (TIM)]	C
491Dh	00h	R-OUT13 output function	U8	RW	No	○	0 to 255 [Initial value: 134 (MOVE)]	C
491Eh	00h	R-OUT14 output function	U8	RW	No	○	0 to 255 [Initial value: 138 (IN-POS)]	C
491Fh	00h	R-OUT15 output function	U8	RW	No	○	0 to 255 [Initial value: 140 (TLC)]	C

■ Input signal list

To assign signals via EtherCAT communication, use the "Assignment No." in the table instead of the signal names.

Assignment No.	Signal name	Function	Status
0	Not used	Set when the input terminal is not used.	–
1	FREE	Cut off the current of the motor not to excite it. When an electromagnetic brake motor is used, the electromagnetic brake is in a state of releasing.	0: No motion 1: Electromagnetic brake is in a state of releasing + motor non-excitation
3	CLR	Clear the deviation (position deviation) between the command position and actual position to zero.	0: No motion 1: Clear deviation
5	STOP	Stop the motor.	0: No motion 1: Stop operation
8	ALM-RST	Release the alarm that is present.	0: No motion 1: Reset alarm
9	P-PRESET	Rewrite the mechanical home to the current position.	0: No motion 1: Execute preset
12	ETO-CLR	Puts the motor in a state where it can be excited after the power removal function is released.	0: No motion 1: Transition to a state of allowing motor excitation
13	LAT-CLR	Clear the cumulative load. This is used when the "Cumulative load value auto clear (41B3h)" is set to "0: Disable."	0: No motion 1: Clear cumulative load
14	INFO-CLR	Release the information status.	0: No motion 1: Release information status
16	HMI	Release the function limitation of the MEXE02 .	0: Function limitation 1: Release the function limitation
18	CCM	Change the control mode from the normal mode to the current control mode.	0: Normal mode 1: Current control mode
19	PLS-XMODE	Change the number of input pulses and the magnification of the frequency.	0: No motion 1: Change magnification
20	PLS-DIS	Disable the pulse input.	0: No motion 1: Pulse input disable
21	T-MODE	Disable the overload alarm.	0: No motion 1: Disable the overload alarm
22	CRNT-LMT	Execute current limiting.	0: Release the current limitation 1: Current limitation
23	SPD-LMT	Execute speed limiting. This signal cannot be used in the cyclic synchronous position mode (CSP).	0: Release the speed limiting 1: Speed limiting
26	FW-BLK	Stop operation in the forward direction.	0: No motion 1: Stop the forward direction operation
27	RV-BLK	Stop operation in the reverse direction.	0: No motion 1: Stop the reverse direction operation
28	FW-LS	A signal input from the limit sensor in the forward direction.	0: OFF 1: ON
29	RV-LS	A signal input from the limit sensor in the reverse direction.	0: OFF 1: ON
30	HOMES	A signal input from the mechanical home sensor.	0: OFF 1: ON
31	SLIT	A signal input from the slit sensor.	0: OFF 1: ON

Assignment No.	Signal name	Function	Status
80	R0	General signals.	0: OFF 1: ON
81	R1		
82	R2		
83	R3		
84	R4		
85	R5		
86	R6		
87	R7		
88	R8		
89	R9		
90	R10		
91	R11		
92	R12		
93	R13		
94	R14		
95	R15		
96	CON	This signal is used to excite the motor. Use when pulse-input operation is performed.	0: Motor non-excitation 1: Motor excitation
104	EXT1	This is an external latch signal of the touch probe 1.	0: OFF 1: ON
105	EXT2	This is an external latch signal of the touch probe 2.	0: OFF 1: ON

Note

- When the same input signal is assigned to multiple input terminals, the function is executed if any of the terminals has input.
- When the HMI input is not assigned to the input terminals, this input is always turned 1. Also, when this input is assigned to both direct I/O (DIN0 to DIN5) and remote I/O (R-IN0 to R-IN15), the function is executed only when both of them are turned 1.

■ Output signals list

To assign signals via EtherCAT communication, use the "Assignment No." in the table instead of the signal names.

Assignment No.	Signal name	Function	Status
0	Not used	Set when the output terminal is not used.	–
1 to 127	Response signals (input signal_R)	Output in response to the corresponding input signal.	0: Input signal is OFF 1: Input signal is ON
128	CONST-OFF	Output an OFF state all the time.	0: OFF
129	ALM-A	Output the alarm status of the driver (normally open).	0: Alarm not present 1: Alarm present
130	ALM-B	Output the alarm status of the driver (normally closed).	0: Alarm present 1: Alarm not present
131	SYS-RDY	Output when the control power supply of the driver is turned on.	0: During system preparation 1: System preparation is complete
132	READY	Output when the driver is ready to operate.	0: Not ready 1: Ready for operation
133	PLS-RDY	Output when the pulse input is enabled.	0: Pulse input is disabled 1: Pulse input is enabled
134	MOVE	Output when the motor operates.	0: Motor stopped 1: Motor operating

Assignment No.	Signal name	Function	Status
135	INFO	Output the information status of the driver.	0: Information not present 1: Information present
136	SYS-BSY	Output when the driver is in internal processing status.	0: No internal processed 1: During internal processing
137	ETO-MON	Output after the driver transitions to the power removal status until the motor puts into a state that can be excited.	0: Excitation possible 1: Excitation not possible
138	IN-POS	Output when the positioning operation is complete. This signal is not output in the cyclic synchronous position mode (CSP).	0: During positioning operation 1: Positioning operation is complete
140	TLC	Output when the output torque reaches the upper limit value.	0: Inside torque range 1: Outside torque range
141	VA	Output when the operating speed reaches the target speed. This signal is not output in the cyclic synchronous position mode (CSP).	0: Not reach the target speed 1: Reach the target speed
142	CRNT	Output while the motor is excited.	0: Motor non-excitation 1: Motor excitation
143	AUTO-CD	Output when the motor is in automatic current cutback status.	0: Normal 1: Automatic current cutback status
144	HOME-END	Output upon completion of return-to-home operation and when position preset (P-PRESET) is executed.	0: Not home 1: Home
145	ABSPEN	Output when the position coordinate is set.	0: Position coordinate is not set 1: Position coordinate is set
149	PRST-DIS	Output when preset is required again to operate the motor after preset.	0: Normal 1: Preset is not set
150	PRST-STLD	Output when the mechanical home is set.	0: Mechanical home is not set 1: Mechanical home has set
151	ORGN-STLD	Output when a mechanical home suitable to the product is set at the time of factory shipment.	0: Mechanical home is not set 1: Mechanical home has set
152	RND-OVF	Output is inverted when the wrap range is exceeded. (Toggle action)	0 and 1 are switched every time the wrap range is exceeded.
153	FW-SLS	Output when the software limit in the forward direction is reached.	0: Not reached the software limit in the forward direction 1: Reached the software limit in the forward direction
154	RV-SLS	Output when the software limit in the reverse direction is reached.	0: Not reached the software limit in the reverse direction 1: Reached the software limit in the reverse direction
155	ZSG	Output every time the actual position of the motor rotates one revolution from the preset position.	0: Normal 1: Motor one revolution
156	RND-ZERO	Output if the motor is at the home of wrap range when the "Wrap setting (41C7h)" is set to "Enable."	0: Not wrap home 1: Wrap home
157	TIM	Output every time the motor output shaft rotates 7.2° with reference to the command position.	0: OFF 1: ON

Assignment No.	Signal name	Function	Status
160	AREA0	Output when the motor is within the AREA0.	0: Outside AREA 1: Inside AREA
161	AREA1	Output when the motor is within the AREA1.	
162	AREA2	Output when the motor is within the AREA2.	
163	AREA3	Output when the motor is within the AREA3.	
164	AREA4	Output when the motor is within the AREA4.	
165	AREA5	Output when the motor is within the AREA5.	
166	AREA6	Output when the motor is within the AREA6.	
167	AREA7	Output when the motor is within the AREA7.	
168	MPS	Output when the main power supply is turned on.	0: Main power supply OFF 1: Main power supply ON
169	MBC	Output when the electromagnetic brake is in a state of releasing.	0: Electromagnetic brake is a state of holding. 1: Electromagnetic brake is a state of releasing.
170	RG	Output when the motor is in a regeneration state.	0: Normal 1: Regeneration state
172	EDM-MON	Output when both HWTO1 and HWTO2 input signals are turned OFF.	0: OFF 1: ON
173	HWTOIN-MON	Output when either HWTO1 or HWTO2 input signal is turned OFF.	0: OFF 1: ON
180	USR-OUT0	Output AND or OR of two types of output signals.	0: OFF 1: ON
181	USR-OUT1		
192	CRNT-LMTD	Output when current limiting is executed.	0: Without current limitation 1: With current limitation
193	SPD-LMTD	Output when speed limiting is executed.	0: Without speed limiting 1: With speed limiting
196	OPE-BSY	Output when internal oscillation is executed.	0: No internal oscillation 1: During internal oscillation
203	PLS-LOST	Output if a pulse is input when the pulse input is disabled.	0: OFF 1: ON
204	DCMD-RDY	Output when the driver is ready to operate.	0: Not ready 1: Ready for operation
205	DCMD-FULL	Output when data is written in the buffer area. If an operation of Set of Set-points is performed in the profile position mode, the operation command is written in the buffer area.	0: No data in buffer 1: Data in buffer
224	INFO-USRIO	Output when corresponding information is generated.	0: Information not present 1: Information present
225	INFO-POSERR		
226	INFO-DRVTMP		
227	INFO-MTRTMP		
228	INFO-OVOLT		
229	INFO-UVOLT		
230	INFO-OLTIME		
232	INFO-SPD		

Assignment No.	Signal name	Function	Status
233	INFO-START	Output when corresponding information is generated.	0: Information not present 1: Information present
234	INFO-ZHOME		
235	INFO-PR-REQ		
237	INFO-EGR-E		
238	INFO-RND-E		
240	INFO-FW-OT		
241	INFO-RV-OT		
242	INFO-CULD0		
243	INFO-CULD1		
244	INFO-TRIP		
245	INFO-ODO		
252	INFO-DSLMTD		
253	INFO-IOTEST		
254	INFO-CFG		
255	INFO-RBT		

5 Position coordinate management

5-1 Overview of position coordinate management

The **AZ** Series manages the position coordinate of the motor with the ABZO sensor (mechanical multi-rotation absolute sensor). The present position coordinate is mechanically recorded inside the ABZO sensor. Therefore, even if the motor output shaft was externally rotated while the power was OFF, the absolute coordinate against the home can be maintained.

The coordinate is set in the following flow.

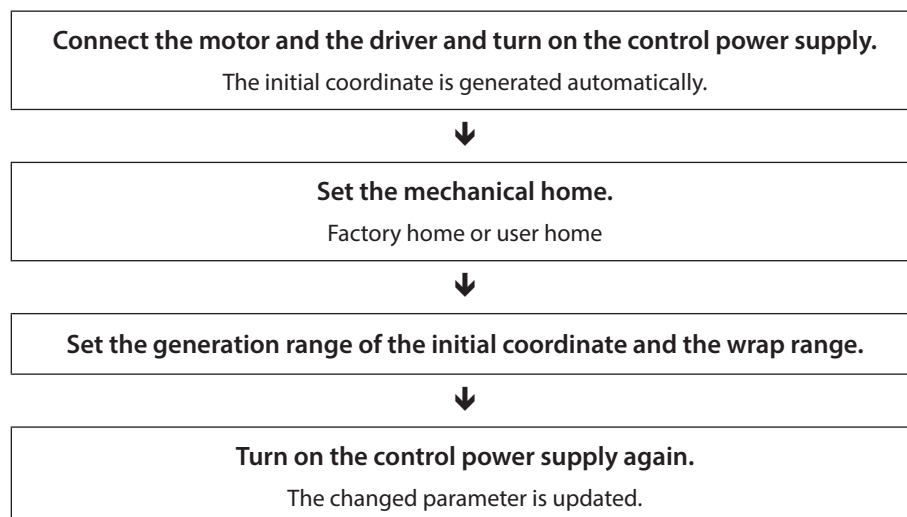

■ About ABZO sensor

The ABZO sensor is a mechanical multi-rotation absolute sensor that does not require a battery. It stores the present position as an absolute position until the number of revolutions of the motor output shaft exceeds 1,800 (*). The present position is maintained even if the control power supply is turned off. The number of count is reset to 0 when the number exceeds 1,800 (*), and the number is newly counted from 1. * The multi-rotation amount varies depending on the motor frame size. Check with the following table.

Multi-rotation amount of ABZO sensor

Motor frame size [mm(in.)]	Specifications of ABZO sensor
20 (0.79), 28 (1.10)	900 revolutions
40 (1.57), 42 (1.65), 60 (2.36), 85 (3.35), 90 (3.54)	1,800 revolutions

■ About initial coordinate generation

Initial coordinate generation indicates to decide how to use the rotation range of up to 1,800 revolutions (or 900 revolutions) that the ABZO sensor can manage. There are four parameters required for initial coordinate generation as shown next. These parameters are read when the control power supply is turned on.

- Initial coordinate generation & wrap coordinate setting (47F2h)
- Initial coordinate generation & wrap setting range (41C9h)
- Initial coordinate generation & wrap range offset ratio (41CBh)
- Initial coordinate generation & wrap range offset value (41CCh)



Regardless of whether the wrap function is enabled or disabled, the initial coordinate is generated whenever the control power supply is turned on.

● **Factory setting example of the motor**

An example of the motor of the frame size 60 mm (2.36 in.) is shown. To use coordinates both in forward and reverse directions, 1,800 revolutions are divided into positive and negative revolutions, 50 % for each direction.

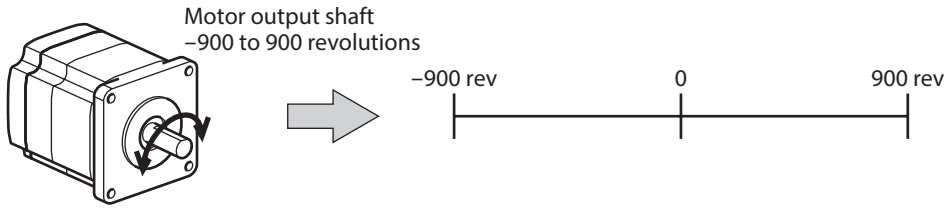

● **Setting example of motorized actuator**

The following is an example to set the home of a motorized actuator to 30 mm from the motor side.

- Model of motorized actuator: 4
- Stroke of motorized actuator: 600 mm
- Pitch of motorized actuator: 6 mm/rev

Concept of initial coordinate

$$\text{Initial coordinate generation range} = \frac{\text{Stroke}}{\text{Pitch}} = \frac{600}{6} = 100 \text{ rev}$$

$$\text{Wrap range offset ratio} = \frac{\text{Home}}{\text{Stroke}} \times 100 = \frac{30}{600} \times 100 = 5 \%$$

From the above, the actual coordinate is in the range of -5 to 95 revolutions.

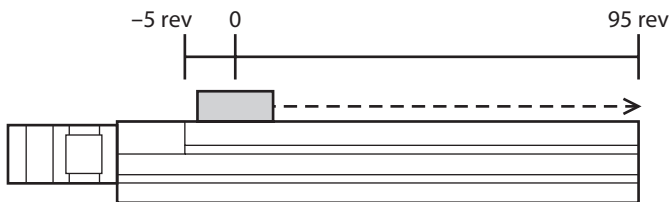

Setting example of parameters

Index	Parameter name	Setting value
47F2h	Initial coordinate generation & wrap coordinate setting	1: Manual setting
41C9h	Initial coordinate generation & wrap setting range [1=0.1 rev]	1,000
41CBh	Initial coordinate generation & wrap range offset ratio [1=0.01 %]	500
41CCh	Initial coordinate generation & wrap range offset value	0 step

■ Wrap function

The wrap function is a function to automatically preset the position information of the current position when the number of revolutions of the motor output shaft exceeds the set range. Setting of wrap offset allows you to limit the operation area of the equipment and control the index table with coordinates on the positive and negative sides. For the specific setting methods, refer to p.171.

Note To set the wrap function, change the "Initial coordinate generation & wrap coordinate setting (47F2h)" to "1: Manual setting." [Initial value: 0 (Prioritize ABZO setting)]
When this parameter is changed, turn on the control power supply of the driver again.

● Concept of wrap setting

This explains as an example for the motor of the frame size 60 mm (2.36 in.).

With wrap setting, 1,800 revolutions managed by the ABZO sensor are divided evenly to generate coordinates within the number of revolutions divided evenly.

Therefore, set a value by which 1,800 can exactly be divided.

Example: When the wrap function executes if the motor rotates 180 times in the same direction

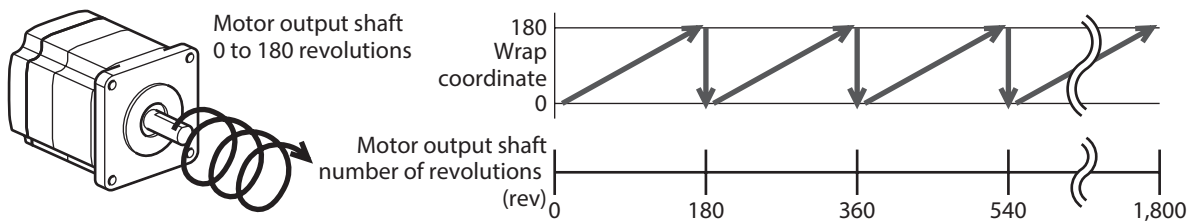

The present position of the motor is preset every 180 revolutions, however, the 32-bit counter in the driver is not preset.

Example: When the range of use of the motor is offset to -90 to 90 revolutions

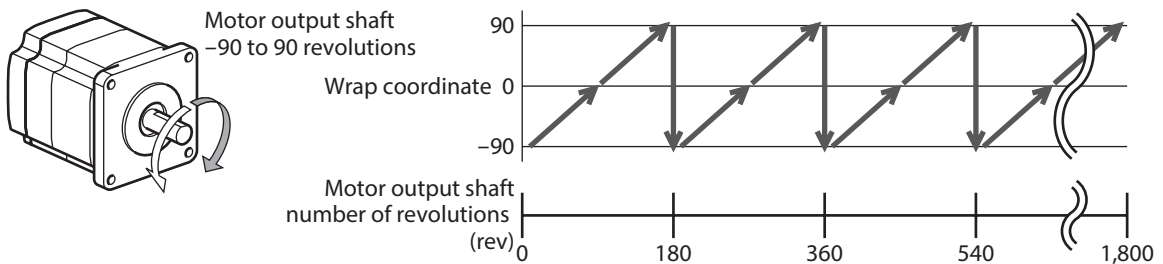

When the wrap setting range is exceeded, the symbol is reversed.

● **Setting example of index table**

This is an example in which the index table is made rotate once when the motor output shaft rotates 18 times.

- Gear ratio of motor: 18

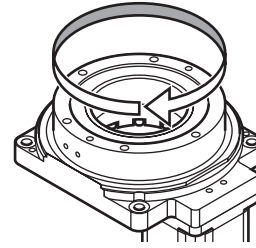

Concept of initial coordinate

To allow the index table to rotate in both directions, 18 revolutions are divided into positive and negative rotations, 50 % for each direction.

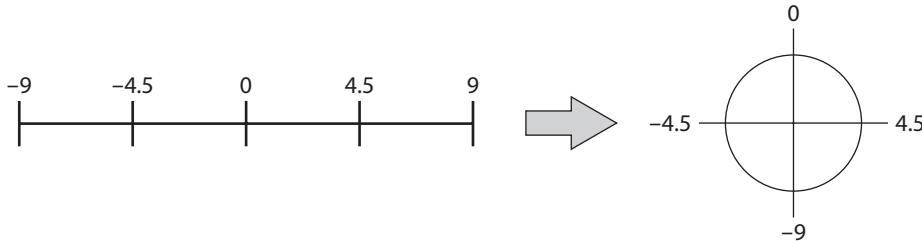

Setting example of parameters

Index	Parameter name	Setting value
47F2h	Initial coordinate generation & wrap coordinate setting	1: Manual setting
41C7h	Wrap setting	1: Enable
41C9h	Initial coordinate generation & wrap setting range [1=0.1 rev]	180
41CBh	Initial coordinate generation & wrap range offset ratio [1=0.01 %]	5,000
41CCh	Initial coordinate generation & wrap range offset value	0 step

● **Relationship between the wrap function and the 32-bit counter inside the driver**

The 32-bit counter inside the driver outputs the position information of the motor as the number of steps regardless of whether the wrap function is enabled or disabled.

When the wrap function is enabled, the relationship between the wrap coordinate and 32-bit counter are as follows.

Example:

If the wrap function is performed when the motor rotates 180 revolutions in the same direction

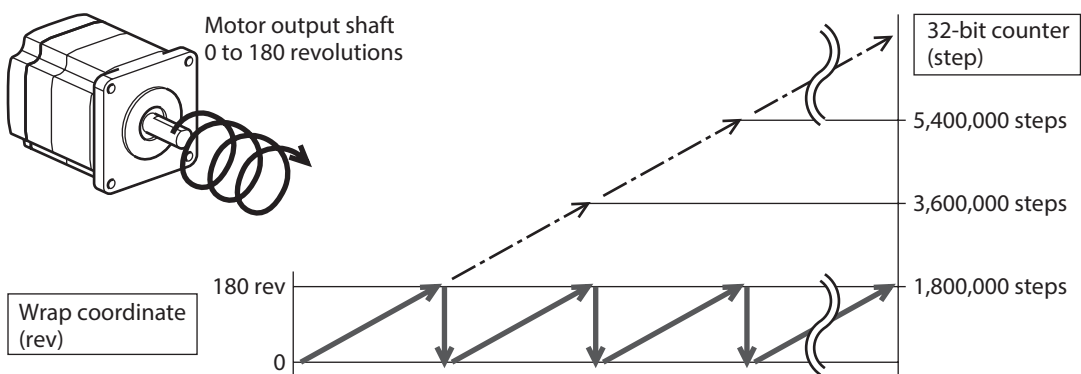

The present position of the motor is preset by 180 revolutions, but the 32-bit counter is not preset. The value of the 32-bit counter can be checked by the "Command position 32-bit counter (4091h)." The 32-bit counter goes around between -2,147,483,648 to 2,147,483,647.

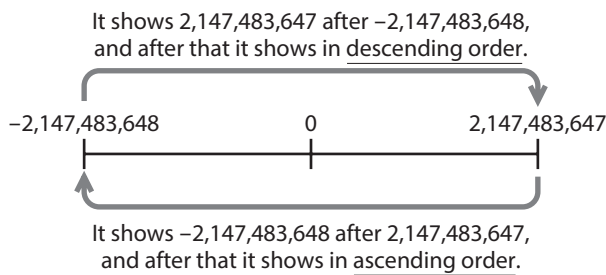

5-2 Position coordinate origin

When the position coordinate has been set, the ABSPEN output is turned ON.

- Note** If the position coordinate has not been set, the next operation cannot be performed.
- High-speed return-to-home operation
 - Absolute positioning operation (when the "Permission of absolute positioning without setting absolute coordinates (4148h)" is "0: Disable")

Related object

Index	Parameter name	Description	Initial value
4148h	Permission of absolute positioning without setting absolute coordinates	Permits absolute positioning operation when the position coordinate is not set. Setting range 0: Disable 1: Enable	0

■ Mechanical home

The mechanical home is the home stored by the ABZO sensor. The mechanical home includes the "factory home" written in the ABZO sensor at the time of factory shipment and the "user home" set by performing return-to-home operation or position preset (P-PRESET).

● Factory home

The factory home is set in products with which the mechanism is pre-assembled to the motor, such as motorized actuators. It cannot be changed.
If the factory home is set, the ORGN-STLD output is turned ON.

● User home

When the user home is set by performing return-to-home operation or position preset (P-PRESET), the PRST-STLD output is turned ON. The user home can be released by "Position preset clear" of the **MEXE02**.
If the user home is set, the home information is written to the non-volatile memory. The non-volatile memory can be rewritten approximately 100,000 times.

■ Setting of mechanical home

To set the mechanical home, perform the position preset (P-PRESET) or return-to-home operation. When the mechanical home coordinate is set, operation is performed on coordinates with the mechanical home in the center.

● Position preset

When position preset (P-PRESET) is executed, the command position and the actual position have the values set in the "Home offset (607Ch)" and the home is set.

Related objects

Index	Parameter name	Description	Initial value
607Ch	Home offset	Sets the preset position. Setting range –2,147,483,648 to 2,147,483,647 steps	0
4148h	Permission of absolute positioning without setting absolute coordinates	Permits absolute positioning operation when the position coordinate is not set. Setting range 0: Disable 1: Enable	0

● Return-to-home operation

When return-to-home operation is performed, the mechanical home can be set.

■ Cases in which the position coordinate is not set

In the following cases, the position coordinate is not set. The ABSPEN output is turned OFF.

- Factory setting
- When position preset (P-PRESET) is performed with the "Home offset (607Ch)" set to a value other than "0" and then resolution is changed.
- When "Position preset clear" under "Communication" menu of the **MEXE02** is executed.
- During return-to-home operation

5-3 Parameters related to ABZO sensor

With the **AZ** Series, the specification of the ABZO sensor and parameters based on the pre-assembled mechanism to the motor are written in the ABZO sensor in advance.

Related objects

Index	Parameter name	Description	Initial value
47F0h	Mechanism settings	To change the mechanism settings parameter, select manual setting. Setting range 0: Prioritize ABZO setting 1: Manual setting	1
47F1h	Gear ratio setting	Sets the gear ratio for geared motor. When "0: Gear ratio setting disable" is set, the gear ratio is considered as "1." Setting range 0: Gear ratio setting disable 1 to 32,767: Gear ratio (1=0.01)	0
47F2h	Initial coordinate generation & wrap coordinate setting	To change the initial coordinate generation & wrap coordinate parameter, select manual setting. Setting range 0: Prioritize ABZO setting 1: Manual setting	0
47F3h	Mechanism limit parameter setting	Disables the ABZO setting of the mechanism limit parameter. Setting range 0: Follow ABZO setting 1: Disable	0

Index	Parameter name	Description	Initial value
47F4h	Mechanism protection parameter setting	Disables the ABZO setting of the mechanism protection parameter. Setting range 0: Follow ABZO setting 1: Disable	0
47F5h	JOG/HOME/ZHOME operation setting	To change the parameter for JOG operation and return-to-home operation, select manual setting. Setting range 0: Prioritize ABZO setting 1: Manual setting	0

■ When the parameter of the wrap function is set

● Setting example: When the wrap range is set to –50 to 50 revolutions

- Change the "Initial coordinate generation & wrap coordinate setting (47F2h)" to "1: Manual setting." When it is changed to "1: Manual setting," the following driver parameters can be set manually.
 - Wrap setting
 - The number of the RND-ZERO output in wrap range
 - Initial coordinate generation & wrap setting range
 - Initial coordinate generation & wrap range offset ratio
 - Initial coordinate generation & wrap range offset value
- Set each parameters as follows.

Index	Parameter name	Setting value
41C7h	Wrap setting	1: Enable
41CDh	The number of the RND-ZERO output in wrap range	1
41C9h	Initial coordinate generation & wrap setting range [1=0.1 rev]	1,000
41CBh	Initial coordinate generation & wrap range offset ratio [1=0.01 %]	5,000
41CCh	Initial coordinate generation & wrap range offset value	0 step

5-4 Mechanism settings parameter

The mechanism settings parameter is a parameter required for combined use with the mechanism such as the geared motor and motorized actuator.

Note To change the mechanism settings parameter, change the "Mechanism settings (47F0h)" to "1: Manual setting." [Initial value: 1 (Manual setting)]
When this parameter is changed, turn on the control power supply of the driver again.

■ Motor rotation direction

Set the relationship between the coordinate system of the motor and the actual rotation direction.

Related object

Index	Parameter name	Description	Initial value
41C2h	Motor rotation direction	Sets the rotation direction of the motor output shaft. Setting range 0: Positive side=Counterclockwise 1: Positive side=Clockwise 2: Positive side=Counterclockwise (the driver parameter is applied) 3: Positive side=Clockwise (the driver parameter is applied)	1

5-5 Initial coordinate generation & wrap coordinate parameter

These are parameters to be used for generation of the coordinate system.

■ Wrap function

For the wrap function, refer to p.166.

● Related operation mode wrap absolute push-motion

When the following operations are performed with the profile position mode (PP), set the wrap function.

- Wrap absolute positioning operation
- Wrap proximity positioning operation
- Wrap forward direction absolute positioning operation
- Wrap reverse direction absolute positioning operation
- Wrap absolute push-motion operation
- Wrap proximity push-motion operation
- Wrap forward direction push-motion operation
- Wrap reverse direction push-motion operation

Related objects

Index	Parameter name	Description	Initial value
414Fh	Wrap positioning mode	Sets the operation mode for wrap positioning operation. Setting range 0: Wrap absolute positioning 1: Wrap proximity 2: Wrap forward direction 3: Wrap reverse direction	0
47F2h	Initial coordinate generation & wrap coordinate setting	To use the wrap function, select manual setting. Setting range 0: Prioritize ABZO setting 1: Manual setting	0
41C7h	Wrap setting	Sets the wrap function. Setting range 0: Disable 1: Enable	1
41C9h	Initial coordinate generation & wrap setting range	Sets the wrap range. The command position returns to 0 when the motor has rotated for the number of times set here. Setting range Refer to the next table. (1=0.1 rev)	10
41CBh	Initial coordinate generation & wrap range offset ratio	Sets the offset ratio of the wrap range. Setting range 0 to 10,000 (1=0.01 %)	5,000
41CCh	Initial coordinate generation & wrap range offset value	Sets the amount of offset of the wrap range. Setting range -536,870,912 to 536,870,911 steps	0

Value that can be set in the "Initial coordinate generation & wrap setting range (41C9h)"

Since the internal coordinate of the ABZO sensor is 1,800 rev (or 900 rev), select a value from the table, and set in the "Initial coordinate generation & wrap setting range (41C9h)."

In the table, the values which are surrounded with thick box border cannot be set in 900 rev.

memo The table shows the values when setting with the **MEXE02**. When setting via EtherCAT, multiply the values in the table by 10.

Wrap setting range [rev]						
0.5	1.8	4.8	12.0	25.0	72.0	200.0
0.6	2.0	5.0	12.5	30.0	75.0	225.0
0.8	2.4	6.0	14.4	36.0	90.0	300.0
0.9	2.5	7.2	15.0	37.5	100.0	360.0
1.0	3.0	7.5	18.0	40.0	112.5	450.0
1.2	3.6	8.0	20.0	45.0	120.0	600.0
1.5	4.0	9.0	22.5	50.0	150.0	900.0
1.6	4.5	10.0	24.0	60.0	180.0	1,800.0

● **Setting example**

When "Initial coordinate generation & wrap range offset ratio (41CBh)" is set to "50 %" and "Initial coordinate generation & wrap range offset value (41CCh)" to "0 step"

Example 1: Coordinate when the wrap setting range is 1 rev and the resolution is 10,000 P/R

Index	Sub	Parameter name	Setting value
6091h	01h	Electronic gear A	1
	02h	Electronic gear B	1
47F2h	00h	Initial coordinate generation & wrap coordinate setting	1: Manual setting
41C7h	00h	Wrap setting	1: Enable
41C9h	00h	Initial coordinate generation & wrap setting range [1=0.1 rev]	10
41CBh	00h	Initial coordinate generation & wrap range offset ratio [1=0.01 %]	5,000
41CCh	00h	Initial coordinate generation & wrap range offset value	0 step

Position coordinate image

When the parameters are set as in the table above, the motor can be operated on coordinates in the figure.

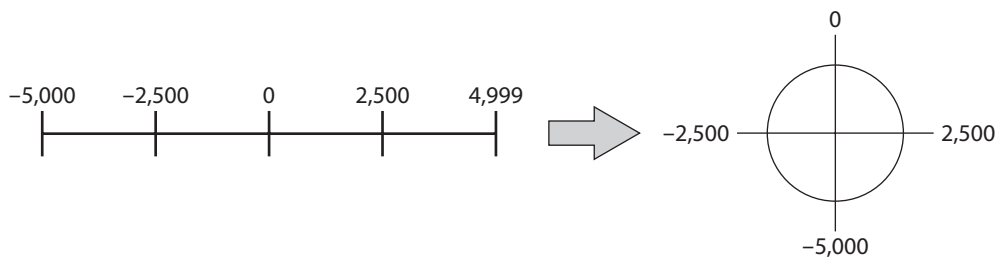

Example 2: Coordinate when the wrap setting range is 1,800 rev and the resolution is 10,000 P/R

Index	Sub	Parameter name	Setting value
6091h	01h	Electronic gear A	1
	02h	Electronic gear B	1
47F2h	00h	Initial coordinate generation & wrap coordinate setting	1: Manual setting
41C7h	00h	Wrap setting	1: Enable
41C9h	00h	Initial coordinate generation & wrap setting range [1=0.1 rev]	18,000
41CBh	00h	Initial coordinate generation & wrap range offset ratio [1=0.01 %]	5,000
41CCh	00h	Initial coordinate generation & wrap range offset value	0 step

Position coordinate image

When the parameters are set as in the table above, the motor can be operated on coordinates in the figure.

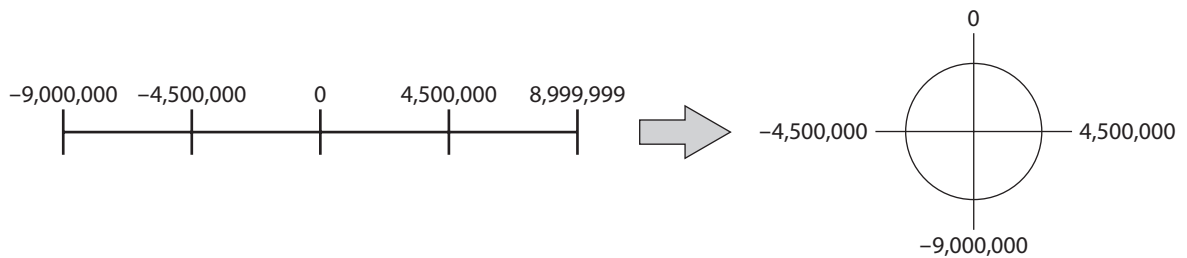

If the "Wrap setting (41C7h)" or the "Initial coordinate generation & wrap setting range (41C9h)" is changed, the absolute position may be shifted. When the parameter is changed, perform preset (P-PRESET) or return-to-home operation.

- **Setting condition of the "Initial coordinate generation & wrap setting range (41C9h)"**

When the wrap range meets the following condition, continuous rotation in the same direction becomes possible with the home maintained.

$$\text{Condition (1)} \quad \frac{1,800 *}{\text{Wrap setting range}} = \text{Integer} \quad * \text{ The motors of frame size 20 mm (0.79 in.) and 28 mm (1.10 in.) are 900.}$$

$$\text{Condition (2)} \quad \text{Wrap setting range} \times \text{Resolution} = \text{Wrap setting range} \times \frac{\text{Electronic gear B}}{\text{Electronic gear A}} \times 10,000 = \text{Integer}$$



If the setting condition of the "Initial coordinate generation & wrap setting range (41C9h)" is not met even though the "Wrap setting (41C7h)" is set to "1: Enable," information of wrap setting error is generated. If the control power supply is turned on again or configuration is executed while the information of wrap setting error is present, an alarm of wrap setting error is generated.

Setting example 1

- Wrap setting range: 100 rev
- Resolution: 10,000 P/R (electronic gear A=1, electronic gear B=1)
- Motor: Standard motor (gear ratio 1)

$$\text{Condition (1)} \quad \frac{1,800}{\text{Wrap setting range}} = \frac{1,800}{100} = 18$$

$$\text{Condition (2)} \quad \text{Wrap setting range} \times \frac{\text{Electronic gear B}}{\text{Electronic gear A}} \times 10,000 = 100 \times \frac{1}{1} \times 10,000 = 1,000,000$$

Both Condition (1) and (2) are integers and this meets the setting condition. Wrap function can be executed.

Setting example 2

- Wrap setting range: 14.4 rev
- Resolution: 3,333.333... P/R (electronic gear A=3, electronic gear B=1)
- Motor: **TS** geared type (gear ratio 3.6)

Condition (1) $\frac{1,800}{\text{Wrap setting range}} = \frac{1,800}{14.4} = 125$

Condition (2) $\text{Wrap setting range} \times \frac{\text{Electronic gear B}}{\text{Electronic gear A}} \times 10,000 = 14.4 \times \frac{1}{3} \times 10,000 = 48,000$

Both Condition (1) and (2) are integers and this meets the setting condition. Wrap function can be executed.

Setting example 3

- Wrap setting range: 4.5 rev
- Resolution: 10,000 P/R (electronic gear A=1, electronic gear B=1)
- Actuator: **DGII** Series (gear ratio 18)

Condition (1) $\frac{1,800}{\text{Wrap setting range}} = \frac{1,800}{4.5} = 400$

Condition (2) $\text{Wrap setting range} \times \frac{\text{Electronic gear B}}{\text{Electronic gear A}} \times 10,000 = 4.5 \times \frac{1}{1} \times 10,000 = 45,000$

Both Condition (1) and (2) are integers and this meets the setting condition. In the case of this setting, wrap function is executed every time the motor rotates by 90 degrees on the output shaft of **DGII** Series.

Setting example 4

- Wrap setting range: 1,000 rev
- Resolution: 10,000 P/R (electronic gear A=1, electronic gear B=1)
- Motor: **PS** geared type (gear ratio 20)

Condition (1) $\frac{1,800}{\text{Wrap setting range}} = \frac{1,800}{1,000} = 1.8$

Condition (2) $\text{Wrap setting range} \times \text{Resolution} = 1,000 \times 10,000 = 10,000,000$

Condition (1) is not an integer and this does not meet the setting condition. The information of wrap setting error is generated and wrap function cannot be executed.

■ **Wrap offset function**

The position of the boundary point of the wrap range can be offset by using the mechanical home as a reference. Wrap offset is set in the "Initial coordinate generation & wrap range offset ratio (41CBh)" and the "Initial coordinate generation & wrap range offset value (41CCh)."

● **Wrap offset ratio setting**

When the "Initial coordinate generation & wrap range offset ratio (41CBh)" is set, the wrap range can be offset in the negative direction.

Setting example: When the wrap range is 1,800 rev and the resolution is 10,000 P/R

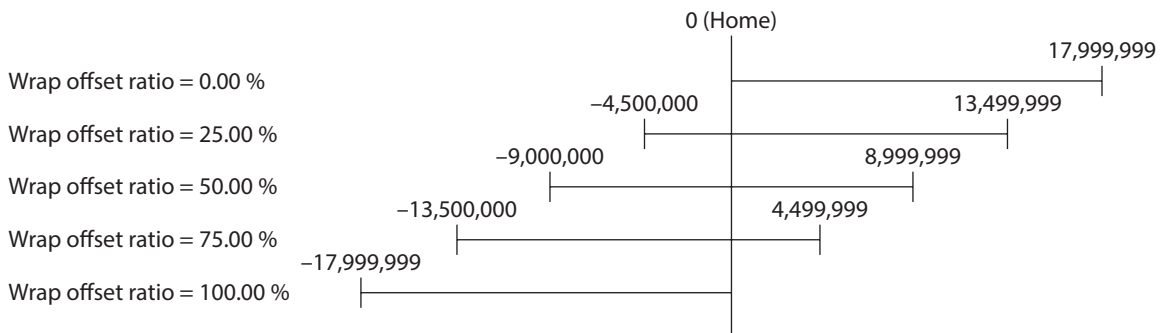

- **Wrap range offset value setting**

For the coordinate system offset in the "Initial coordinate generation & wrap range offset ratio (41CBh)," the coordinate can be shifted by step.

Note When the coordinate is set in the "Initial coordinate generation & wrap range offset value (41CCh)," information of wrap setting error is generated if the home is not included in the coordinate. If the control power supply is turned on again or configuration is executed while the information of wrap setting error is present, an alarm of wrap setting error is generated.

Setting example 1:

When the wrap range is 1,800 rev, the resolution 10,000 P/R, and the wrap offset ratio setting 50 %.

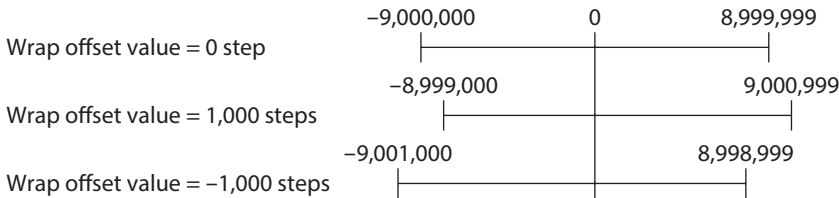

Setting example 2:

When the wrap range is 1,800 rev, the resolution 10,000 P/R, and the wrap offset ratio setting 0 %.

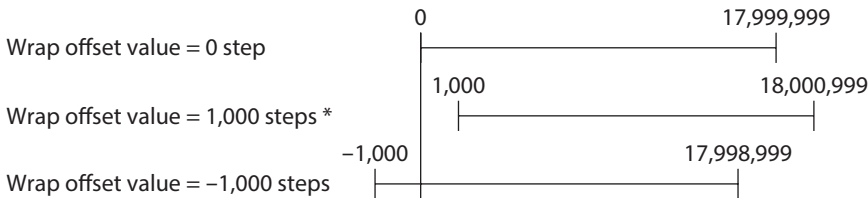

* Information of wrap setting error is generated

- **RND-ZERO output**

The RND-ZERO output is a signal output for each boundary point of division when the wrap range is divided evenly with the home as a reference. The number of division can be set in the "The number of the RND-ZERO output in wrap range (41CDh)." The RND-ZERO output is output when the "Wrap setting (41C7h)" parameter is set to "1: Enable."

- **Usage example 1**

When the RND-ZERO signal is output for every rotation of the output shaft
(In case of wrap range of 1,800 rev and a geared motor of gear ratio 7.2)

$$\text{The number of the RND-ZERO output in wrap range} = \frac{\text{Wrap range}}{\text{Gear ratio}} = \frac{1,800}{7.2} = 250$$

In this usage example, you can check that the motor is in the home. With a geared motor, it can be used as a Z-phase signal that outputs one pulse for every rotation.

- **Usage example 2**

When the movable range is evenly divided by 90 degrees and the RND-ZERO signal is output for a certain travel amount

$$\text{Number of division of movable range} = \frac{360^\circ}{90^\circ} = 4$$

$$\text{The number of the RND-ZERO output in wrap range} = \frac{\text{Wrap range}}{\text{Gear ratio}} \times \text{Number of division of movable range} = \frac{1,800}{18} \times 4 = 400$$

In this usage example, the signal can be output regularly during operation of the motorized actuator or hollow rotary actuator. It can be used to synchronize multiple motors and to operate by inputting the RND-ZERO signal to other system.

Related object

Index	Parameter name	Description	Initial value
41CDh	The number of the RND-ZERO output in wrap range	Sets the number of times to turn the RND-ZERO output ON in the wrap range. Setting range 1 to 536,870,911 divisions	1

6 Save of parameters

The parameters are saved in RAM or non-volatile memory of the driver. The parameters saved in RAM are erased once the control power supply is cut off, however, the parameters saved in the non-volatile memory are saved even if the control power supply is cut off. When the control power is applied to the driver, the parameters saved in the non-volatile memory are sent to RAM, and the recalculation and setup for the parameters are executed in RAM.

When the parameters are set to driver via EtherCAT communication, they are saved in the RAM space.

To save the parameters stored in the RAM to the non-volatile memory, execute the "Write batch NV memory (40C9h)" of the maintenance command.



Do not turn off the control power supply while writing in the non-volatile memory, and also do not turn off within 5 seconds after the completion of writing. Doing so may abort writing the data and cause an alarm of EEPROM error to generate (alarm code 41h).



The non-volatile memory can be rewritten approximately 100,000 times.

■ How to execute maintenance commands

The following two methods are available to execute maintenance commands. Use them selectively in accordance with the intended use.

● Writing 1 to data (recommended)

When data is changed from 0 to 1 after 1 is written to it, the command is executed.

To execute the same command again, restore the data to 0 and then write 1. It is safe, because the command is not executed in succession even if 1 is written from the MainDevice continuously.

● Writing 2 to data

When 2 is written to data, the command is executed. After execution, the data is restored to 1 automatically.

Data does not need to restore to 1, and it can be written consecutively.

If commands which take time to write to the non-volatile memory such as "Write batch NV memory (40C9h)" are executed consecutively, increase the length of the intervals between commands.

7 Object dictionary

This chapter explains the details of objects.

7-1 Composition of the object dictionary

Objects are constructed as follows.

Index (Hex)	Object	Overview
1000h to 1FFFh	CoE communication area	CoE communication area
2000h to 3FFFh	Manufacturer specific area	Not used
4000h to 4FFFh		Driver object
5000h to 5FFFh		Not used
6000h to 67FFh	Profile area	Profile area

■ Object dictionary item

Item	Description																																				
Index, sub, name	Index, sub-Index, and name of objects																																				
Type	<p>Definition objects of data type. Abbreviations described in the table below are used in this manual.</p> <table border="1"> <thead> <tr> <th>Abbreviation</th> <th>Data type</th> <th>Description</th> <th>Range of value</th> </tr> </thead> <tbody> <tr> <td>BOOL</td> <td>Boolean</td> <td>1-bit unsigned data</td> <td>0, 1</td> </tr> <tr> <td>INT8</td> <td>Integer8</td> <td>8-bit signed data</td> <td>-128 to 127</td> </tr> <tr> <td>INT16</td> <td>Integer16</td> <td>16-bit signed data</td> <td>-32,768 to 32,767</td> </tr> <tr> <td>INT32</td> <td>Integer32</td> <td>32-bit signed data</td> <td>-2,147,483,648 to 2,147,483,647</td> </tr> <tr> <td>U8</td> <td>Unsigned8</td> <td>8-bit unsigned data</td> <td>0 to 255</td> </tr> <tr> <td>U16</td> <td>Unsigned16</td> <td>16-bit unsigned data</td> <td>0 to 65,535</td> </tr> <tr> <td>U32</td> <td>Unsigned32</td> <td>32-bit unsigned data</td> <td>0 to 4,294,967,295</td> </tr> <tr> <td>STRING</td> <td>Visible String</td> <td>Character string</td> <td>-</td> </tr> </tbody> </table>	Abbreviation	Data type	Description	Range of value	BOOL	Boolean	1-bit unsigned data	0, 1	INT8	Integer8	8-bit signed data	-128 to 127	INT16	Integer16	16-bit signed data	-32,768 to 32,767	INT32	Integer32	32-bit signed data	-2,147,483,648 to 2,147,483,647	U8	Unsigned8	8-bit unsigned data	0 to 255	U16	Unsigned16	16-bit unsigned data	0 to 65,535	U32	Unsigned32	32-bit unsigned data	0 to 4,294,967,295	STRING	Visible String	Character string	-
Abbreviation	Data type	Description	Range of value																																		
BOOL	Boolean	1-bit unsigned data	0, 1																																		
INT8	Integer8	8-bit signed data	-128 to 127																																		
INT16	Integer16	16-bit signed data	-32,768 to 32,767																																		
INT32	Integer32	32-bit signed data	-2,147,483,648 to 2,147,483,647																																		
U8	Unsigned8	8-bit unsigned data	0 to 255																																		
U16	Unsigned16	16-bit unsigned data	0 to 65,535																																		
U32	Unsigned32	32-bit unsigned data	0 to 4,294,967,295																																		
STRING	Visible String	Character string	-																																		
Access	<p>Access method of objects.</p> <ul style="list-style-type: none"> • RW: Read and write of values are possible. • RO: Only read of values is possible. 																																				
PDO	<p>Indicates whether the PDO mapping of objects is possible.</p> <ul style="list-style-type: none"> • RxPDO: Mapping to RxPDO is possible. • TxPDO: Mapping to TxPDO is possible. • No: Mapping to PDO is not possible. 																																				
Save	<p>Indicates whether data is saved in the non-volatile memory when the batch non-volatile memory write was executed.</p> <ul style="list-style-type: none"> • O: Saved in the non-volatile memory. • -: Not saved in the non-volatile memory. 																																				
Update	<p>Indicates the timing to update the change when a value in the object was changed.</p> <ul style="list-style-type: none"> • A: Update immediately • B: Update after operation stop • C: Update after executing the configuration • D: Update after cycling the control power supply ON again 																																				

7-2 Objects of the CoE communication area

These are objects to set about EtherCAT communication or to indicate the status.

- **Device type (1000h)**

Indicates the device profile.

Index	Sub	Name	Type	Access	PDO	Save	Range	Update
1000h	00h	Device type	U32	RO	No	–	0004 0192h	–

Details of range

Bit	Name	Description
0 to 15	Device profile	0192h: DS402
16 to 31	Additional information	0004h: ST Single axis driver

- **Error register (1001h)**

Indicates the error status of the driver. If an error occurs in the driver, the "General error (bit0)" is changed to 1. It is changed to 0 when the error is cleared.

Index	Sub	Name	Type	Access	PDO	Save	Range	Update
1001h	00h	Error register	U8	RO	No	–	Bit0: General error Bit1 to 7: Reserved	–

- **Manufacturer device name (1008h)**

Indicates the product model.

Index	Sub	Name	Type	Access	PDO	Save	Range	Update
1008h	00h	Manufacturer device name	STRING	RO	No	–	AZD-AED AZD-CED AZD-KED*	–

* The **AZD-KED2** is indicated as "**AZD-KED**."

- **Manufacturer hardware version (1009h)**

Indicates the hardware version of the driver. "V.1.00" is indicated when the version is 1.00.

Index	Sub	Name	Type	Access	PDO	Save	Range	Update
1009h	00h	Manufacturer hardware version	STRING	RO	No	–	Hardware version	–

- **Manufacturer software version (100Ah)**

Indicates the software version of the driver. "V.1.00" is indicated when the version is 1.00.

Index	Sub	Name	Type	Access	PDO	Save	Range	Update
100Ah	00h	Manufacturer software version	STRING	RO	No	–	Software version	–

- **Identity object (1018h)**

Indicates the product information of the driver. The serial number is always 0.

Index	Sub	Name	Type	Access	PDO	Save	Range	Update
1018h	00h	Number of entries	U8	RO	No	–	4	–
	01h	Vendor ID	U32	RO	No	–	0000 02BEh	–
	02h	Product code	U32	RO	No	–	AZD-AED: 0000 13E9h AZD-CED: 0000 13EAh AZD-KED2: 0000 13E5h	–
	03h	Revision number	U32	RO	No	–	0000 xxxxh	–
	04h	Serial number	U32	RO	No	–	0	–

- **Receive PDO mapping 1 (1600h)**

Sets the receive PDO mapping 1.

Index	Sub	Name	Type	Access	PDO	Save	Range	Update
1600h	00h	Number of entries	U8	RW	No	–	0 to 16 (Initial value: 3)	A
	01h	Mapping entry 1	U32	RW	No	–	0000 0000h to FFFF FFFFh (Initial value: 6040 0010h)	A
	02h	Mapping entry 2	U32	RW	No	–	0000 0000h to FFFF FFFFh (Initial value: 607A 0020h)	A
	03h	Mapping entry 3	U32	RW	No	–	0000 0000h to FFFF FFFFh (Initial value: 6060 0008h)	A
	04h	Mapping entry 4	U32	RW	No	–	0000 0000h to FFFF FFFFh (Initial value: 0000 0000h)	A
	05h	Mapping entry 5	U32	RW	No	–		A
	06h	Mapping entry 6	U32	RW	No	–		A
	07h	Mapping entry 7	U32	RW	No	–		A
	08h	Mapping entry 8	U32	RW	No	–		A
	09h	Mapping entry 9	U32	RW	No	–		A
	0Ah	Mapping entry 10	U32	RW	No	–		A
	0Bh	Mapping entry 11	U32	RW	No	–		A
	0Ch	Mapping entry 12	U32	RW	No	–		A
	0Dh	Mapping entry 13	U32	RW	No	–		A
	0Eh	Mapping entry 14	U32	RW	No	–		A
	0Fh	Mapping entry 15	U32	RW	No	–		A
10h	Mapping entry 16	U32	RW	No	–	A		

- **Receive PDO mapping 2 (1601h)**

Sets the receive PDO mapping 2.

Index	Sub	Name	Type	Access	PDO	Save	Range	Update
1601h	00h	Number of entries	U8	RW	No	–	0 to 16 (Initial value: 5)	A
	01h	Mapping entry 1	U32	RW	No	–	0000 0000h to FFFF FFFFh (Initial value: 6040 0010h)	A
	02h	Mapping entry 2	U32	RW	No	–	0000 0000h to FFFF FFFFh (Initial value: 607A 0020h)	A
	03h	Mapping entry 3	U32	RW	No	–	0000 0000h to FFFF FFFFh (Initial value: 60FF 0020h)	A
	04h	Mapping entry 4	U32	RW	No	–	0000 0000h to FFFF FFFFh (Initial value: 6060 0008h)	A
	05h	Mapping entry 5	U32	RW	No	–	0000 0000h to FFFF FFFFh (Initial value: 60B8 0010h)	A
	06h	Mapping entry 6	U32	RW	No	–	0000 0000h to FFFF FFFFh (Initial value: 0000 0000h)	A
	07h	Mapping entry 7	U32	RW	No	–		A
	08h	Mapping entry 8	U32	RW	No	–		A
	09h	Mapping entry 9	U32	RW	No	–		A
	0Ah	Mapping entry 10	U32	RW	No	–		A
	0Bh	Mapping entry 11	U32	RW	No	–		A
	0Ch	Mapping entry 12	U32	RW	No	–		A
	0Dh	Mapping entry 13	U32	RW	No	–		A
	0Eh	Mapping entry 14	U32	RW	No	–		A
	0Fh	Mapping entry 15	U32	RW	No	–		A
10h	Mapping entry 16	U32	RW	No	–	A		

- **Transmit PDO mapping 1 (1A00h)**

Sets the transmit PDO mapping 1.

Index	Sub	Name	Type	Access	PDO	Save	Range	Update
1A00h	00h	Number of entries	U8	RW	No	–	0 to 16 (Initial value: 3)	A
	01h	Mapping entry 1	U32	RW	No	–	0000 0000h to FFFF FFFFh (Initial value: 6041 0010h)	A
	02h	Mapping entry 2	U32	RW	No	–	0000 0000h to FFFF FFFFh (Initial value: 6064 0020h)	A
	03h	Mapping entry 3	U32	RW	No	–	0000 0000h to FFFF FFFFh (Initial value: 6061 0008h)	A
	04h	Mapping entry 4	U32	RW	No	–	0000 0000h to FFFF FFFFh (Initial value: 0000 0000h)	A
	05h	Mapping entry 5	U32	RW	No	–		A
	06h	Mapping entry 6	U32	RW	No	–		A
	07h	Mapping entry 7	U32	RW	No	–		A
	08h	Mapping entry 8	U32	RW	No	–		A
	09h	Mapping entry 9	U32	RW	No	–		A
	0Ah	Mapping entry 10	U32	RW	No	–		A
	0Bh	Mapping entry 11	U32	RW	No	–		A
	0Ch	Mapping entry 12	U32	RW	No	–		A
	0Dh	Mapping entry 13	U32	RW	No	–		A
	0Eh	Mapping entry 14	U32	RW	No	–		A
	0Fh	Mapping entry 15	U32	RW	No	–		A
10h	Mapping entry 16	U32	RW	No	–	A		

- **Transmit PDO mapping 2 (1A01h)**

Sets the transmit PDO mapping 2.

Index	Sub	Name	Type	Access	PDO	Save	Range	Update
1A01h	00h	Number of entries	U8	RW	No	–	0 to 16 (Initial value: 8)	A
	01h	Mapping entry 1	U32	RW	No	–	0000 0000h to FFFF FFFFh (Initial value: 6041 0010h)	A
	02h	Mapping entry 2	U32	RW	No	–	0000 0000h to FFFF FFFFh (Initial value: 6064 0020h)	A
	03h	Mapping entry 3	U32	RW	No	–	0000 0000h to FFFF FFFFh (Initial value: 6061 0008h)	A
	04h	Mapping entry 4	U32	RW	No	–	0000 0000h to FFFF FFFFh (Initial value: 60B9 0010h)	A
	05h	Mapping entry 5	U32	RW	No	–	0000 0000h to FFFF FFFFh (Initial value: 60BA 0020h)	A
	06h	Mapping entry 6	U32	RW	No	–	0000 0000h to FFFF FFFFh (Initial value: 60BC 0020h)	A
	07h	Mapping entry 7	U32	RW	No	–	0000 0000h to FFFF FFFFh (Initial value: 603F 0010h)	A
	08h	Mapping entry 8	U32	RW	No	–	0000 0000h to FFFF FFFFh (Initial value: 60FD 0020h)	A
	09h	Mapping entry 9	U32	RW	No	–	0000 0000h to FFFF FFFFh (Initial value: 0000 0000h)	A
	0Ah	Mapping entry 10	U32	RW	No	–		A
	0Bh	Mapping entry 11	U32	RW	No	–		A
	0Ch	Mapping entry 12	U32	RW	No	–		A
	0Dh	Mapping entry 13	U32	RW	No	–		A
	0Eh	Mapping entry 14	U32	RW	No	–		A
	0Fh	Mapping entry 15	U32	RW	No	–		A
10h	Mapping entry 16	U32	RW	No	–	A		

- **Sync manager communication type (1C00h)**

Sets the communication type of sync manager (SM).

Index	Sub	Name	Type	Access	PDO	Save	Range	Update
1C00h	00h	Number of entries	U8	RO	No	–	4	–
	01h	Communication type sync manager 0	U8	RO	No	–	1: Mailbox output (MainDevice to driver)	–
	02h	Communication type sync manager 1	U8	RO	No	–	2: Mailbox input (Driver to MainDevice)	–
	03h	Communication type sync manager 2	U8	RO	No	–	3: Process data output (MainDevice to driver)	–
	04h	Communication type sync manager 3	U8	RO	No	–	4: Process data input (Driver to MainDevice)	–

- **Sync manager 2 PDO assignment (1C12h)**

Sets the object assigned in the process data output (receive PDO: RxPDO) of the sync manager 2 (SM2).

It can be changed when the EtherCAT communication state machine is pre-operational.

Refer to "Setting of PDO mapping object" on p.106 for how to set the PDO mapping.

Index	Sub	Name	Type	Access	PDO	Save	Range	Update
1C12h	00h	Number of entries	U8	RW	No	–	0 to 1 (Initial value: 1)	A
	01h	Index of assigned PDO 1	U16	RW	No	–	0000h to FFFFh (Initial value: 1600h)	A

- **Sync manager 3 PDO assignment (1C13h)**

Sets the object assigned in the process data input (transmit PDO: TxPDO) of the sync manager3 (SM3).

It can be changed when the EtherCAT communication state machine is pre-operational.

Refer to "Setting of PDO mapping object" on p.106 for how to set the PDO mapping.

Index	Sub	Name	Type	Access	PDO	Save	Range	Update
1C13h	00h	Number of entries	U8	RW	No	–	0 to 1 (Initial value: 1)	A
	01h	Index of assigned PDO 1	U16	RW	No	–	0000h to FFFFh (Initial value: 1A00h)	A

- **Sync manager 2 synchronization (1C32h)**

Sets the synchronization type of the sync manager 2 (SM2) and indicates the status.

Index	Sub	Name	Type	Access	PDO	Save	Range	Update
1C32h	00h	Number of entries	U8	RO	No	–	20h	–
	01h	Synchronization type	U16	RW	No	–	00h to 02h (Initial value: 01h)	A
	02h	Cycle time [ns]	U32	RO	No	–	–	–
	03h	Shift time [ns]	U32	RO	No	–	0	–
	04h	Synchronization types supported	U16	RO	No	–	0007h	–
	05h	Minimum cycle time [ns]	U32	RO	No	–	0003 D090h (250,000 ns)	–
	06h	Calc and copy time [ns]	U32	RO	No	–	0001 86A0h (100,000 ns)	–
	07h	Reserved	U32	–	–	–	–	–
	08h	Reserved	U16	–	–	–	–	–
	09h	Delay time [ns]	U32	RO	No	–	0	–
	0Ah to 1Fh	Reserved	U16	–	–	–	–	–
	20h	Sync error	BOOL	RO	No	–	0	–

Details of sync manager 2 synchronization object

Sub	Name	Description
01h	Synchronization type	00h: Free run mode (asynchronous) 01h: Sync manager 2 event synchronization mode 02h: DC mode (SYNC0 event synchronization)
02h	Cycle time [ns]	Indicates the cycle time of the SYNC0 event.
03h	Shift time [ns]	The shift time is not supported. The read value is always 0.
04h	Synchronization types supported	Indicates the synchronization type supported. Bit0: Free run mode (asynchronous) Bit1: Sync manager 2 event synchronization mode Bit2: DC mode (SYNC0 event synchronization)
05h	Minimum cycle time [ns]	Indicates the minimum cycle time supported.
06h	Calc and copy time [ns]	Indicates the minimum value of the internal calc and copy time that is needed from the sync manager 2 event to the SYNC0 event.
09h	Delay time [ns]	The delay time is not supported. The read value is always 0.
20h	Sync error	Changes to 1 if the sync error is detected.

● Sync manager 3 synchronization (1C33h)

Sets the synchronization type of the sync manager 3 (SM3) and indicates the status.

Index	Sub	Name	Type	Access	PDO	Save	Range	Update
1C33h	00h	Number of entries	U8	RO	No	–	20h	–
	01h	Synchronization type	U16	RW	No	–	00h, 02h, 22h (Initial value: 22h)	A
	02h	Cycle time [ns]	U32	RO	No	–	–	–
	03h	Shift time [ns]	U32	RO	No	–	0	–
	04h	Synchronization Types supported	U16	RO	No	–	0007h	–
	05h	Minimum cycle time [ns]	U32	RO	No	–	0003 D090h (250,000 ns)	–
	06h	Calc and Copy Time [ns]	U32	RO	No	–	0002 49F0h (150,000 ns)	–
	07h	Reserved	U32	–	–	–	–	–
	08h	Reserved	U16	–	–	–	–	–
	09h	Delay time [ns]	U32	RO	No	–	–	–
	0Ah to 1Fh	Reserved	U16	–	–	–	–	–
	20h	Sync error	BOOL	RO	No	–	0	–

Details of sync manager 3 synchronization object

Sub	Name	Description
01h	Synchronization type	00h: Free run mode (asynchronous) 02h: DC mode (SYNC0 event synchronization) 22h: Sync manager 2 event synchronization mode
02h	Cycle time [ns]	Indicates the cycle time of the SYNC0 event.
03h	Shift time [ns]	The shift time is not supported. The read value is always 0.
04h	Synchronization types supported	Indicates the synchronization type supported. Bit0: Free run mode (asynchronous) Bit1: Sync manager 2 event synchronization mode Bit2: DC mode (SYNC0 event synchronization)
05h	Minimum cycle time [ns]	Indicates the minimum cycle time supported.
06h	Calc and copy time [ns]	Indicates the minimum value of the internal calc and copy time that is needed from the sync manager 3 event to the SYNC0 event.
09h	Delay time [ns]	The delay time is not supported. The read value is always 0.
20h	Sync error	Changes to 1 if the sync error is detected.

7-3 Objects of the profile area

Objects in the profile area are defined by the CiA402 drive profile. Operations of the driver are set, and the status is indicated.

- **Error code (603Fh)**

Indicates the error code being generated in the driver.

Index	Sub	Name	Type	Access	PDO	Save	Range	Update
603Fh	00h	Error code	U16	RO	TxPDO	–	–	–



If an alarm is generated in the driver, the error code is indicated. The lower 8 bits of the error code represents the alarm code, and the upper 8 bits represents FFh. When an alarm is not present, "0000h" is indicated. Refer to p.219 for alarm code.

- **Controlword (6040h)**

Controls the transition of the drive state machine, start/stop of an operation, and others.

Index	Sub	Name	Type	Access	PDO	Save	Range	Update
6040h	00h	Controlword	U16	RW	RxPDO	–	0000h to FFFFh (Initial value: 0000h)	A

Details of range

Bit	Name	Description
0	Switch on	Controls the status of the drive state machine. Refer to "State transition of the drive state machine" on p.111 for details.
1	Enable voltage	
2	Quick stop	
3	Enable operation	
4	Operation mode specific	It varies according to the operation mode. For details, refer to each operation mode of the "3 Drive profile"
5		
6		
7	Fault reset	Resets the alarm by changing from 0 to 1.
8	Halt	For details, refer to each operation mode of the "3 Drive profile"
9	Operation mode specific	
10	Reserved	Reserved
11	Manufacturer specific	Manufacturer-specific bit. For details, refer to each operation mode of the "3 Drive profile"
12		
13		
14		
15		

● Statusword (6041h)

Indicates the status of the drive state machine and the operation status of the driver.

Index	Sub	Name	Type	Access	PDO	Save	Range	Update
6041h	00h	Statusword	U16	RO	TxPDO	–	–	–

Details of range

Bit	Name	Description
0	Ready to switch on	Indicates the status of the drive state machine. Refer to "Status output of the drive state machine" on p.112 for details.
1	Switched on	
2	Operation enabled	
3	Fault	
4	Voltage enabled	
5	Quick stop	
6	Switch on disabled	
7	Warning	Changes to 1 if information of the driver is generated. When the information status is resolved, it is automatically cleared to 0.
8	Manufacturer specific	Manufacturer-specific bit. For details, refer to each operation mode of the "3 Drive profile"
9	Remote	Changes to 1 when the driver initialization is complete.
10	Target reached	It varies according to the operation mode. For details, refer to each operation mode of the "3 Drive profile"
11	Internal limit active	Indicates the status of the function limitation by the internal limit. For details, refer to each operation mode of the "3 Drive profile"
12	Operation mode specific	It varies according to the operation mode. For details, refer to each operation mode of the "3 Drive profile"
13		
14	Manufacturer specific	Manufacturer-specific bit. For details, refer to each operation mode of the "3 Drive profile"
15		

● Quick stop option code (605Ah)

Sets the action by the quick stop command. When the setting is changed while the quick stop is operating, the new setting is applied after stop.

Index	Sub	Name	Type	Access	PDO	Save	Range	Update
605Ah	00h	Quick stop option code	INT16	RW	No	○	0, 1, 2 (Initial value), 3, 5, 6, 7	A

Details of range

Setting value	Description
0	Current off
1	Decelerates to a stop at the "Profile deceleration (6084h)." Moves to "Switch on disabled" after stop.
2	Decelerates to a stop at the "Quick stop deceleration (6085h)." Moves to "Switch on disabled" after stop.
3	Stops immediately. Moves to "Switch on disabled" after stop.
5	Decelerates to a stop at the "Profile deceleration (6084h)." Keeps "Quick stop active" after stop.
6	Decelerates to a stop at the "Quick stop deceleration (6085h)." Keeps "Quick stop active" after stop.
7	Stops immediately. Keeps "Quick stop active" after stop.



If the quick stop command is executed while decelerating to a stop, the deceleration switches to the quick stop deceleration. However, when the deceleration stop is performed by the STOP input signal the deceleration will not switch even if the quick stop command is executed.

- **Shutdown option code (605Bh)**

Sets the operation for when moving from "Operation enabled" to "Ready to switch on."

Index	Sub	Name	Type	Access	PDO	Save	Range	Update
605Bh	00h	Shutdown option code	INT16	RW	No	○	0, 1 (Initial value)	A

Details of range

Setting value	Description
0	Current off
1	Decelerates to a stop at the "Profile deceleration (6084h)." The motor changes to a non-excitation state after stop.

- **Disable operation option code (605Ch)**

Sets the operation for when moving from "Operation enabled" to "Switched on."

Index	Sub	Name	Type	Access	PDO	Save	Range	Update
605Ch	00h	Disable operation option code	INT16	RW	No	○	0, 1 (Initial value)	A

Details of range

Setting value	Description
0	Current off
1	Decelerates to a stop at the "Profile deceleration (6084h)." The motor changes to a non-excitation state after stop.

- **Halt option code (605Dh)**

Sets the operation for when the "Halt (bit8)" of the "Controlword (6040h)" was set.

Index	Sub	Name	Type	Access	PDO	Save	Range	Update
605Dh	00h	Halt option code	INT16	RW	No	○	1 (Initial value), 2, 3	A

Details of range

Setting value	Description
1	Decelerates to a stop at the "Profile deceleration (6084h)." Keeps "Operation enabled" after stop.
2	Decelerates to a stop at the "Quick stop deceleration (6085h)." Keeps "Operation enabled" after stop.
3	Stops immediately. Keeps "Operation enabled" after stop.

- **Modes of operation (6060h)**

Sets the operation mode of the driver. Change the operation mode while the motor is stopped. When the setting is changed during operation, the new setting is updated after stop.

Index	Sub	Name	Type	Access	PDO	Save	Range	Update
6060h	00h	Modes of operation	INT8	RW	RxPDO	○	0 (Initial value), 1, 3, 6, 8, 9	B

Details of range

Setting value	Description
0	Operation function disable
1	Profile position mode (PP)
3	Profile velocity mode (PV)
6	Homing mode (HM)
8	Cyclic synchronous position mode (CSP)
9	Cyclic synchronous velocity mode (CSV)

- **Modes of operation display (6061h)**

Indicates the operation mode that is enabled actually. The range is the same as "Modes of operation (6060h)."

Index	Sub	Name	Type	Access	PDO	Save	Range	Update
6061h	00h	Modes of operation display	INT8	RO	TxPDO	–	–	–

- **Position demand value (6062h)**

Indicates the command position. When the "Wrap setting (41C7h)" is set to 1, the value in the wrap range is indicated.

Index	Sub	Name	Type	Access	PDO	Save	Range	Update
6062h	00h	Position demand value [step]	INT32	RO	TxPDO	–	–	–

- **Position actual value (6064h)**

Indicates the present position detected by the ABZO sensor. When the "Wrap setting (41C7h)" is set to 1, the value in the wrap range is indicated.

Index	Sub	Name	Type	Access	PDO	Save	Range	Update
6064h	00h	Position actual value [step]	INT32	RO	TxPDO	–	–	–

- **Following error window (6065h)**

Sets the condition under which the excessive position deviation alarm is generated.

Index	Sub	Name	Type	Access	PDO	Save	Range	Update
6065h	00h	Following error windo [1=0.01 rev]	U32	RW	No	○	1 to 30,000 (Initial value: 300)	A

- **Position window (6067h)**

Sets the output range of the positioning completion output (IN-POS). It is the same as the "IN-POS positioning completion signal range" parameter of the **AZ** Series.

In the profile position mode, after positioning operation is properly completed, the Target Reached (6041h: Bit10) of the statusword changes 1 when the feedback position has converged in a range of the Position window (6067h) with respect to the command position.

The IN-POS output range can be offset by the "IN-POS positioning completion signal offset (4704h)."

Index	Sub	Name	Type	Access	PDO	Save	Range	Update
6067h	00h	Position window [1=0.1°]	U32	RW	No	○	0 to 180 (Initial value: 18)	A

- **Velocity demand value (606Bh)**

Indicates the present velocity demand value. (Hz)

Index	Sub	Name	Type	Access	PDO	Save	Range	Update
606Bh	00h	Velocity demand value [Hz]	INT32	RO	TxPDO	–	–	–

- **Velocity actual value (606Ch)**

Indicates the present feedback speed. (Hz)

Index	Sub	Name	Type	Access	PDO	Save	Range	Update
606Ch	00h	Velocity actual value [Hz]	INT32	RO	TxPDO	–	–	–

- **Target position (607Ah)**

Sets the target position in the cyclic synchronous position mode and profile position mode.

Index	Sub	Name	Type	Access	PDO	Save	Range	Update
607Ah	00h	Target position [step]	INT32	RW	RxPDO	–	–2,147,483,648 to 2,147,483,647 (Initial value: 0)	A

- **Home offset (607Ch)**

Offsets the home after completing return-to-home operation in the homing mode. The command position and the actual position after completing return-to-home will be the value set in the home offset.

Since the offset value is written to the same register as the "Preset position (41C6h)," if the "Home offset (607Ch)" is changed, the "Preset position (41C6h)" will be the same value.

Index	Sub	Name	Type	Access	PDO	Save	Range	Update
607Ch	00h	Home offset [step]	INT32	RW	No	<input type="radio"/>	-2,147,483,648 to 2,147,483,647 (Initial value: 0)	A

- **Software position limit (607Dh)**

Sets the software limit. The Min. position limit represents the limit of the reverse direction, and the Max. position limit represents the limit of the forward direction.

Index	Sub	Name	Type	Access	PDO	Save	Range	Update
607Dh	00h	Number of entries	U8	RO	No	-	2	-
	01h	Min. position limit [step]	INT32	RW	No	<input type="radio"/>	-2,147,483,648 to 2,147,483,647 (Initial value: -2,147,483,648)	A
	02h	Max. position limit [step]	INT32	RW	No	<input type="radio"/>	-2,147,483,648 to 2,147,483,647 (Initial value: 2,147,483,647)	A

- **Max profile velocity (607Fh)**

Sets the maximum speed for the profile position mode (PP) and the profile velocity mode (PV). When the setting is changed during operation, the new setting is updated after stop.

When the setting value of the Max profile velocity (607Fh) is lower than the Starting speed (4142h), self-start operation (rectangular operation) is performed at the Max profile velocity (607Fh).

Index	Sub	Name	Type	Access	PDO	Save	Range	Update
607Fh	00h	Max profile velocity [Hz]	U32	RW	RxPDO	<input type="radio"/>	0 to 4,000,000 (Initial value: 1,000,000)	B

- **Profile velocity (6081h)**

Sets the operating speed of the profile position mode.

Index	Sub	Name	Type	Access	PDO	Save	Range	Update
6081h	00h	Profile velocity [Hz]	U32	RW	RxPDO	<input type="radio"/>	0 to 4,000,000 (Initial value: 10,000)	A

- **Profile acceleration (6083h)**

Sets the acceleration for the profile position mode and profile velocity mode.

Index	Sub	Name	Type	Access	PDO	Save	Range	Update
6083h	00h	Profile acceleration [step/s ²]	U32	RW	RxPDO	<input type="radio"/>	1 to 1,000,000,000 (Initial value: 300,000)	B

- **Profile deceleration (6084h)**

Sets the deceleration for the profile position mode and profile velocity mode.

Index	Sub	Name	Type	Access	PDO	Save	Range	Update
6084h	00h	Profile deceleration [step/s ²]	U32	RW	RxPDO	<input type="radio"/>	1 to 1,000,000,000 (Initial value: 300,000)	B

- **Quick stop deceleration (6085h)**

Sets the deceleration for the quick stop. This is the deceleration for when the quick stop command of the drive state machine was enabled while the "Quick stop option code (605Ah)" was set to 2 or 6.

Index	Sub	Name	Type	Access	PDO	Save	Range	Update
6085h	00h	Quick stop deceleration [step/s ²]	U32	RW	RxPDO	○	1 to 1,000,000,000 (Initial value: 1,000,000)	B

- **Gear ratio (6091h)**

Sets the electronic gear. The electronic gear A is the denominator of the electronic gear, and the electronic gear B is the numerator of the electronic gear.

If the electronic gear is set, the resolution per revolution of the motor output shaft can be changed. Refer to "4-2 Resolution" on p.150 for details.

Index	Sub	Name	Type	Access	PDO	Save	Range	Update
6091h	00h	Number of entries	U8	RO	No	–	2	–
	01h	Electronic gear A	U32	RW	No	○	1 to 65,535 (Initial value: 1)	C
	02h	Electronic gear B	U32	RW	No	○	1 to 65,535 (Initial value: 1)	C

- **Homing method (6098h)**

Sets the return-to-home method for return-to-home operation. Refer to p.134 for details.

Index	Sub	Name	Type	Access	PDO	Save	Range	Update
6098h	00h	Homing method	INT8	RW	No	○	17, 18, 24 (Initial value), 28, 35, 37, –1	B

Details of range

Setting value	Description
17	Return-to-home by the limit sensor (FW-LS/RV-LS), starts in the negative direction
18	Return-to-home by the limit sensor (FW-LS/RV-LS), starts in the positive direction
24	Return-to-home by the home sensor (HOMES), starts in the positive direction
28	Return-to-home by the home sensor (HOMES), starts in the negative direction
35, 37 *	Home preset
–1	Return-to-home operation of our specifications

* 35 and 37 perform the same action.

- **Homing speed (6099h)**

Sets the operating speed and feedback speed for return-to-home operation. The feedback speed is the operating speed for when aligning with the home finally.

Index	Sub	Name	Type	Access	PDO	Save	Range	Update
6099h	00h	Number of entries	U8	RO	No	–	2	–
	01h	Speed during search for switch [Hz]	U32	RW	No	○	1 to 4,000,000 (Initial value: 10,000)	B
	02h	Speed during search for zero [Hz]	U32	RW	No	○	1 to 10,000 (Initial value: 5,000)	B

- **Homing acceleration (609Ah)**

Sets the acceleration and deceleration for return-to-home operation.

Index	Sub	Name	Type	Access	PDO	Save	Range	Update
609Ah	00h	Homing acceleration [step/s ²]	U32	RW	No	○	1 to 1,000,000,000 (Initial value: 300,000)	B

- **Touch probe function (60B8h)**

Sets the action of the touch probe. Refer to p.147 for details.

Index	Sub	Name	Type	Access	PDO	Save	Range	Update
60B8h	00h	Touch probe function	U16	RW	RxPDO	–	0000h to FFFFh (Initial value: 0000h)	A

Details of range

Bit	Name	Value	Definition
0	Touch probe 1 permission	0	Disables touch probe 1.
		1	Enables touch probe 1.
1	Touch probe 1 trigger action	0	First trigger action Latches only once on the first trigger.
		1	Continuous operation Latches every time a trigger is input.
2	Touch probe 1 trigger selection	0	Sets the external latch input EXT1 as a trigger.
		1	Sets the ZSG output or TIM output as a trigger.
3	Reserved	0	Reserved
4	Touch probe 1 positive value action	0	Disables the latch function at the positive value of a trigger.
		1	Enables the latch function at the positive value of a trigger.
5	Touch probe 1 negative value action	0	Disables the latch function at the negative value of a trigger.
		1	Enables the latch function at the negative value of a trigger.
6	Reserved	0	Reserved
7	Reserved	0	Reserved
8	Touch probe 2 permission	0	Disables touch probe 2.
		1	Enables touch probe 2.
9	Touch probe 2 trigger action	0	First trigger action Latches only once on the first trigger.
		1	Continuous operation Latches every time a trigger is input.
10	Touch probe 2 trigger selection	0	Sets the external latch input EXT1 as a trigger.
		1	Sets the ZSG output or TIM output as a trigger.
11	Reserved	0	Reserved
12	Touch probe 2 positive value action	0	Disables the latch function at the positive value of a trigger.
		1	Enables the latch function at the positive value of a trigger.
13	Touch probe 2 negative value action	0	Disables the latch function at the negative value of a trigger.
		1	Enables the latch function at the negative value of a trigger.
14	Reserved	0	Reserved
15	Reserved	0	Reserved

- **Touch probe status (60B9h)**

Indicates the status of the touch probe. Refer to p.148 for details.

Index	Sub	Name	Type	Access	PDO	Save	Range	Update
60B9h	00h	Touch probe status	U16	RO	TxPDO	–	–	–

Details of range

Bit	Name	Value	Definition
0	Touch probe 1 permission status	0	Touch probe 1 is disabled.
		1	Touch probe 1 is enabled.
1	Touch probe 1 positive value latch	0	Has not latch on the positive value of the touch probe 1.
		1	Latched on the positive value of the touch probe 1.
2	Touch probe 1 negative value latch	0	Has not latch on the negative value of the touch probe 1.
		1	Latched on the negative value of the touch probe 1.
3 to 7	Reserved	0	Reserved
8	Touch probe 2 permission status	0	Touch probe 2 is disabled.
		1	Touch probe 2 is enabled.
9	Touch probe 2 positive value latch	0	Has not latch on the positive value of the touch probe 2.
		1	Latched on the positive value of the touch probe 2.
10	Touch probe 2 negative value latch	0	Has not latch on the negative value of the touch probe 2.
		1	Latched on the negative value of the touch probe 2.
11 to 15	Reserved	0	Reserved

- **Touch probe position 1 positive value (60BAh)**

Indicates the position latched at the positive value of the touch probe 1.

Index	Sub	Name	Type	Access	PDO	Save	Range	Update
60BAh	00h	Touch probe position 1 positive value [step]	INT32	RO	TxPDO	–	–	–

- **Touch probe position 1 negative value (60BBh)**

Indicates the position latched at the negative value of the touch probe 1.

Index	Sub	Name	Type	Access	PDO	Save	Range	Update
60BBh	00h	Touch probe position 1 negative value [step]	INT32	RO	TxPDO	–	–	–

- **Touch probe position 2 positive value (60BCh)**

Indicates the position latched at the positive value of the touch probe 2.

Index	Sub	Name	Type	Access	PDO	Save	Range	Update
60BCh	00h	Touch probe position 2 positive value [step]	INT32	RO	TxPDO	–	–	–

- **Touch probe position 2 negative value (60BDh)**

Indicates the position latched at the negative value of the touch probe 2.

Index	Sub	Name	Type	Access	PDO	Save	Range	Update
60BDh	00h	Touch probe position 2 negative value [step]	INT32	RO	TxPDO	–	–	–

- **Supported homing methods (60E3h)**

Indicates the method of return-to-home supported by the driver.

Index	Sub	Name	Type	Access	PDO	Save	Range	Update
60E3h	00h	Number of entries	U8	RO	No	–	7	–
	01h	1st supported homing method	INT8	RO	No	–	17	–
	02h	2nd supported homing method	INT8	RO	No	–	18	–
	03h	3rd supported homing method	INT8	RO	No	–	24	–
	04h	4th supported homing method	INT8	RO	No	–	28	–
	05h	5th supported homing method	INT8	RO	No	–	35	–
	06h	6th supported homing method	INT8	RO	No	–	37	–
	07h	7th supported homing method	INT8	RO	No	–	–1	–

Details of range

Setting value	Description
17	Return-to-home by the limit sensor (FW-LS/RV-LS), starts in the negative direction
18	Return-to-home by the limit sensor (FW-LS/RV-LS), starts in the positive direction
24	Return-to-home by the home sensor (HOMES), starts in the positive direction
28	Return-to-home by the home sensor (HOMES), starts in the negative direction
35, 37 *	Home preset
–1	Return-to-home operation of our specifications

* 35 and 37 perform the same action.

- **Following error actual value (60F4h)**

Indicates the deviation between the command position and feedback position (actual position).

Index	Sub	Name	Type	Access	PDO	Save	Range	Update
60F4h	00h	Following error actual value [step]	INT32	RO	TxPDO	–	–	–

● Digital inputs (60FDh)

Indicates the direct I/O status.

Index	Sub	Name	Type	Access	PDO	Save	Range	Update
60FDh	00h	Digital inputs	U32	RO	TxPDO	–	–	–

Details of range

Bit	Name	Description
0	RV-BLK *1	Status of the RV-BLK input (0: OFF, 1: ON) *2
1	FW-BLK *1	Status of the FW-BLK input (0: OFF, 1: ON) *2
2	HOMES *1	Status of the HOMES input (0: OFF, 1: ON) *2
3 to 15	–	Reserved
16	EXT1 *1	Status of the EXT1 input (0: OFF, 1: ON) *2
17	EXT2 *1	Status of the EXT2 input (0: OFF, 1: ON) *2
18, 19	–	Reserved
20	ZSG	Status of the ZSG output (0: OFF, 1: ON) *2
21 to 23	–	Reserved
24	DIN0	Status of the DIN0 input (0: Not carrying current, 1: Carrying current) *3
25	DIN1	Status of the DIN1 input (0: Not carrying current, 1: Carrying current) *3
26	DIN2	Status of the DIN2 input (0: Not carrying current, 1: Carrying current) *3
27	DIN3	Status of the DIN3 input (0: Not carrying current, 1: Carrying current) *3
28	DIN4	Status of the DIN4 input (0: Not carrying current, 1: Carrying current) *3
29	DIN5	Status of the DIN5 input (0: Not carrying current, 1: Carrying current) *3
30, 31	–	Reserved

*1 To acquire the status, input signals are required to assign to the input terminals IN0 to IN5 of the input signal connector (CN7). Assign using the "DIN0 input function (4840h)" to "DIN5 input function (4845h)."

*2 Normally open; ON: Carrying current, OFF: Not carrying current

Normally closed; ON: Not carrying current, OFF: Carrying current

*3 Carrying current or "Not carrying current" state of the internal photocoupler is represented.

● Digital outputs (60FEh)

Controls the electromagnetic brake.

Index	Sub	Name	Type	Access	PDO	Save	Range	Update
60FEh	00h	Number of entries	U8	RO	No	–	2	–
	01h	Physical outputs	U32	RW	RxPDO	–	0000 0000h to FFFF FFFFh (Initial value: 0000 0000h)	A
	02h	Bit mask	U32	RW	No	–	0000 0000h to FFFF FFFFh (Initial value: 0000 0000h)	A

Details of the physical outputs

Bit	Name	Description
0	Electromagnetic brake control	0: Electromagnetic brake release 1: Electromagnetic brake hold
1 to 31	–	Reserved

Details of the bit mask

Bit	Name	Description
0	Mask of bit0	0: Brake control of physical outputs disable 1: Brake control of physical outputs enable
1 to 31	–	Reserved

- **Target velocity (60FFh)**

Sets the operating speed for the cyclic synchronous velocity mode and the profile velocity mode.

Index	Sub	Name	Type	Access	PDO	Save	Range	Update
60FFh	00h	Target velocity [Hz]	INT32	RW	RxPDO	–	–4,000,000 to 4,000,000 (Initial value: 0)	A

- **Supported drive modes (6502h)**

Indicates the operation mode supported by the product.

Index	Sub	Name	Type	Access	PDO	Save	Range	Update
6502h	00h	Supported drive modes	U32	RO	No	–	0000 01A5h	–

Details of range

Bit	Name	Value	Description
0	PP (Profile position mode)	1	1: Supported
1	VL (Velocity mode)	0	0: Not supported
2	PV (Profile velocity mode)	1	1: Supported
3	TQ (Torque profile mode)	0	0: Not supported
4	Reserved	0	Reserved
5	HM (Homing mode)	1	1: Supported
6	IP (Interpolated position mode)	0	0: Not supported
7	CSP (Cyclic synchronous position mode)	1	1: Supported
8	CSV (Cyclic synchronous velocity mode)	1	1: Supported
9	CST (Cyclic synchronous torque mode)	0	0: Not supported
10 to 31	Reserved	0	Reserved

- **Device profile number (67FFh)**

Indicates the device type and profile number.

Index	Sub	Name	Type	Access	PDO	Save	Range	Update
67FFh	00h	Device profile number	U32	RO	No	–	0004 0192h	–

Details of range

Bit	Name	Description
0 to 15	Device profile	0192h: DS402
16 to 31	Device type	0004h: Stepping motor

7-4 Objects of the manufacturer-specific area

These are our specific objects.

Refer to the **AZ Series OPERATING MANUAL Function Edition** for driver objects that are not described in this document.

- **Operation voltage mode (40B7h)**

This is the object for DC power input drivers.

Indicates the voltage mode of the actual main power supply. Sets the voltage mode of the main power supply using the "Main power mode (41FAh)."

Index	Sub	Name	Type	Access	PDO	Save	Range	Update
40B7h	00h	Operation voltage mode	U8	RO	No	–	–	–

Details of range

Setting value	Description
0	The main power supply is not turned on. [When the "Main power mode (41FAh)" is set to –1 (automatic discrimination)]
24	Operates in the 24 VDC mode.
48	Operates in the 48 VDC mode.

- **Filter time constant of torque monitor (413Ah)**

Sets the filter time constant (LPF) of the torque monitor. It does not affect the operation or the response speed of the motor.

Index	Sub	Name	Type	Access	PDO	Save	Range	Update
413Ah	00h	Filter time constant of torque monitor [ms]	U8	RW	No	○	0 to 200 (Initial value: 0)	B

- **Current setting during push-motion (413Ch)**

Setting method of the current of push-motion operation is selected.

When "0: Push current" is selected, set with the "Push current (4121h)." Set the current value other than push-motion operation with the "Operating current (4120h)."

When "1: Operating current" is selected, set the current value for all operation with the "Operating current (4120h)."

Index	Sub	Name	Type	Access	PDO	Save	Range	Update
413Ch	00h	Current setting during push-motion	U8	RW	No	○	0 (initial vlaue), 1	A

Details of range

Setting value	Description
0	Push current
1	Operating current

- **Non-excitation mode selection (413Dh)**

Selects whether to enable the dynamic brake status or the free-run status when the motor is in a non-excitation state. In the dynamic brake status, the motor windings will be in a state of being short-circuited inside the driver, and the braking torque will generate. In the free-run status, the dynamic brake will be disabled, and the braking torque will not generate.

Index	Sub	Name	Type	Access	PDO	Save	Range	Update
413Dh	00h	Non-excitation mode selection	U8	RW	No	○	0 (Initial value), 1	A

Details of range

Setting value	Description
0	Dynamic brake status
1	Free-run status

● Wrap positioning mode (414Fh)

Sets the operation mode for wrap positioning operation.

For details about operation mode, refer to "Operation mode of the profile position mode" on p.121.

Index	Sub	Name	Type	Access	PDO	Save	Range	Update
414Fh	00h	Wrap positioning mode	U8	RW	RxPDO	○	0 (Initial value), 1, 2, 3	B

Details of range

Setting value	Description
0	Wrap absolute positioning
1	Wrap proximity
2	Wrap forward direction
3	Wrap reverse direction

● Main power mode (41FAh)

Sets the voltage mode of the main power supply. (DC power input driver only)

Index	Sub	Name	Type	Access	PDO	Save	Range	Update
41FAh	00h	Main power mode	INT8	RW	No	○	-1 (Initial value), 0, 1	D

Details of range

Setting value	Description
-1	Automatic discrimination (discriminates the input power supply voltage automatically.)
0	24 VDC mode
1	48 VDC mode

Note

- The optimal values in the motor control parameters are set in the driver according to the voltage mode. Unless the voltage mode is set correctly, the torque may decrease or vibration may increase.
- If -1 is set, after the control power supply is supplied, the voltage value is automatically discriminated when the main power supply is turned on first. Be sure to shut off the control power supply before changing the voltage of the main power supply.
- When 48 VDC is used, if the rise time of 50 ms or more is needed while the driver input voltage rises to 32 V from 10 V, set the value to 1 instead of -1 (automatic discrimination). If the rise time is slow, the voltage mode may wrongly be recognized as 24 VDC, resulting in torque deterioration or vibration.
- The voltage mode actually operated can be checked by the "Operation voltage mode (40B7h)."

● Touch probe 1 latch position (44B0h)

Sets the position to latch by the external latch input (EXT1). The changed value is updated when the "Touch probe 1 permission (60B8h: bit0)" is changed from 0 to 1.

Index	Sub	Name	Type	Access	PDO	Save	Range	Update
44B0h	00h	Touch probe 1 latch position	U8	RW	No	○	0 (Initial value), 1	A

Details of range

Setting value	Description
0	Latches the feedback position (actual position).
1	Latches the command position.

- **Touch probe 2 latch position (44B1h)**

Sets the position to latch by the external latch input (EXT2). The changed value is updated when the "Touch probe 2 permission (60B8h: bit8)" is changed from 0 to 1.

Index	Sub	Name	Type	Access	PDO	Save	Range	Update
44B1h	00h	Touch probe 2 latch position	U8	RW	No	○	0 (Initial value), 1	A

Details of range

Setting value	Description
0	Latches the feedback position (actual position).
1	Latches the command position.

- **Touch probe 1 TIM/ZSG signal select (44B2h)**

Sets the TIM output or ZSG output as a trigger. The changed value is updated when the "Touch probe 1 permission (60B8h: bit0)" is changed from 0 to 1.

Index	Sub	Name	Type	Access	PDO	Save	Range	Update
44B2h	00h	Touch probe 1 TIM/ZSG signal select	U8	RW	No	○	0 (Initial value), 1	A

Details of range

Setting value	Description
0	Latches by the ZSG output.
1	Latches by the TIM output.

- **Touch probe 2 TIM/ZSG signal select (44B3h)**

Sets the TIM output or ZSG output as a trigger. The changed value is updated when the "Touch probe 2 permission (60B8h: bit8)" is changed from 0 to 1.

Index	Sub	Name	Type	Access	PDO	Save	Range	Update
44B3h	00h	Touch probe 2 TIM/ZSG signal select	U8	RW	No	○	0 (Initial value), 1	A

Details of range

Setting value	Description
0	Latches by the ZSG output.
1	Latches by the TIM output.

- **Driver CPU number (4642h)**

Indicates the CPU number of the software of the driver.

Index	Sub	Name	Type	Access	PDO	Save	Range	Update
4642h	00h	Driver CPU number	U16	RO	No	–	–	–

- **Driver software version (4643h)**

Indicates the software version of the driver. 0100h is indicated when the version is 1.00.

Index	Sub	Name	Type	Access	PDO	Save	Range	Update
4643h	00h	Driver software version	U16	RO	No	–	–	–

5 Object list

This part describes the lists of the objects supported by the driver.

◆ Table of contents

1	Objects of the CoE communication area.....	201
2	Objects of the profile area	203
3	Objects of the manufacturer-specific area.....	205



■ Notation rules

● Timing to update

When a object is changed, the timing to update the new value varies depending on the object. In this part, each update timing is represented in an alphabet.

Notation	Update timing	Description
A	Update immediately	Recalculation and setup are immediately executed when the parameter is written.
B	Update after operation stop	Recalculation and setup are executed when the operation is stopped.
C	Update after executing Configuration	Recalculation and setup are executed after Configuration is executed or executing write batch non-volatile memory and turning on the control power supply again.
D	Update after turning on the control power supply again	Recalculation and setup are executed after executing write batch non-volatile memory and turning on the control power supply again.

1 Objects of the CoE communication area

These are objects to set about EtherCAT communication or to indicate the status.

Index	Sub	Name	Type	Access	PDO	Save	initial value	Range	Update	
1000h	00h	Device type	U32	RO	No	–	0004 0192h	–	–	
1001h	00h	Error register	U8	RO	No	–	0	–	–	
1008h	00h	Manufacturer device name	STRING	RO	No	–	AZD-AED, AZD-CED, AZD-KED		–	
1009h	00h	Manufacturer hardware version	STRING	RO	No	–	Indicates the version number	–	–	
100Ah	00h	Manufacturer software version	STRING	RO	No	–	Indicates the version number	–	–	
1018h	Identity object									
	00h	Number of entries	U8	RO	No	–	4	–	–	
	01h	Vendor ID	U32	RO	No	–	0000 02BEh	–	–	
	02h	Product code	U32	RO	No	–	AZD-AED: 0000 13E9h AZD-CED: 0000 13EAh AZD-KED2: 0000 13E5h		–	
	03h	Revision number	U32	RO	No	–	0000 xxxxh	–	–	
04h	Serial number	U32	RO	No	–	0	–	–		
1600h	Receive PDO mapping 1 (RxPDO1)									
	00h	Number of entries	U8	RW	No	–	3	0 to 16	A	
	01h	Mapping entry 1	U32	RW	No	–	6040 0010h	0000 0000h to FFFF FFFFh	A	
	02h	Mapping entry 2	U32	RW	No	–	607A 0020h	0000 0000h to FFFF FFFFh	A	
	03h	Mapping entry 3	U32	RW	No	–	6060 0008h	0000 0000h to FFFF FFFFh	A	
04h to 10h	Mapping entry 4-16	U32	RW	No	–	0000 0000h	0000 0000h to FFFF FFFFh	A		
1601h	Receive PDO mapping 2 (RxPDO2)									
	00h	Number of entries	U8	RW	No	–	5	0 to 16	A	
	01h	Mapping entry 1	U32	RW	No	–	6040 0010h	0000 0000h to FFFF FFFFh	A	
	02h	Mapping entry 2	U32	RW	No	–	607A 0020h	0000 0000h to FFFF FFFFh	A	
	03h	Mapping entry 3	U32	RW	No	–	60FF 0020h	0000 0000h to FFFF FFFFh	A	
	04h	Mapping entry 4	U32	RW	No	–	6060 0008h	0000 0000h to FFFF FFFFh	A	
	05h	Mapping entry 5	U32	RW	No	–	60B8 0010h	0000 0000h to FFFF FFFFh	A	
06h to 10h	Mapping entry 6-16	U32	RW	No	–	0000 0000h	0000 0000h to FFFF FFFFh	A		
1A00h	Transmit PDO mapping 1 (TxPDO1)									
	00h	Number of entries	U8	RW	No	–	3	0 to 16	A	
	01h	Mapping entry 1	U32	RW	No	–	6041 0010h	0000 0000h to FFFF FFFFh	A	
	02h	Mapping entry 2	U32	RW	No	–	6064 0020h	0000 0000h to FFFF FFFFh	A	
	03h	Mapping entry 3	U32	RW	No	–	6061 0008h	0000 0000h to FFFF FFFFh	A	
04h to 10h	Mapping entry 4-16	U32	RW	No	–	0000 0000h	0000 0000h to FFFF FFFFh	A		
1A01h	Transmit PDO mapping 2 (TxPDO2)									
	00h	Number of entries	U8	RW	No	–	8	0 to 16	A	
	01h	Mapping entry 1	U32	RW	No	–	6041 0010h	0000 0000h to FFFF FFFFh	A	
	02h	Mapping entry 2	U32	RW	No	–	6064 0020h	0000 0000h to FFFF FFFFh	A	
	03h	Mapping entry 3	U32	RW	No	–	6061 0008h	0000 0000h to FFFF FFFFh	A	
	04h	Mapping entry 4	U32	RW	No	–	60B9 0010h	0000 0000h to FFFF FFFFh	A	
	05h	Mapping entry 5	U32	RW	No	–	60BA 0020h	0000 0000h to FFFF FFFFh	A	
	06h	Mapping entry 6	U32	RW	No	–	60BC 0020h	0000 0000h to FFFF FFFFh	A	
	07h	Mapping entry 7	U32	RW	No	–	603F 0010h	0000 0000h to FFFF FFFFh	A	
08h	Mapping entry 8	U32	RW	No	–	60FD 0020h	0000 0000h to FFFF FFFFh	A		
09h to 10h	Mapping entry 9-16	U32	RW	No	–	0000 0000h	0000 0000h to FFFF FFFFh	A		

Objects of the CoE communication area

Index	Sub	Name	Type	Access	PDO	Save	initial value	Range	Update
1C00h	Sync manager communication type								
	00h	Number of entries	U8	RO	No	-	4	-	-
	01h	Communication type sync manager 0	U8	RO	No	-	1: Mailbox output (MainDevice to driver)		-
	02h	Communication type sync manager 1	U8	RO	No	-	2: Mailbox input (Driver to MainDevice)		-
	03h	Communication type sync manager 2	U8	RO	No	-	3: Process data output (MainDevice to driver)		-
	04h	Communication type sync manager 3	U8	RO	No	-	4: Process data input (Driver to MainDevice)		-
1C12h	Sync manager 2 PDO assignment								
	00h	Number of entries	U8	RW	No	-	1	0, 1	A
	01h	Index of assigned PDO 1	U16	RW	No	-	1600h	0 to FFFFh	A
1C13h	Sync manager 3 PDO assignment								
	00h	Number of entries	U8	RW	No	-	1	0, 1	A
	01h	Index of assigned PDO 1	U16	RW	No	-	1A00h	0 to FFFFh	A
1C32h	Sync manager 2 synchronization								
	00h	Number of entries	U8	RO	No	-	20h	-	-
	01h	Synchronization type	U16	RW	No	-	01h	00h: Free run mode (asynchronous) 01h: Sync manager 2 event synchronization mode 02h: DC mode (SYNC0 event synchronization)	A
	02h	Cycle time [ns]	U32	RO	No	-	-	-	-
	03h	Shift time [ns]	U32	RO	No	-	0	-	-
	04h	Synchronization types supported	U16	RO	No	-	0007h	-	-
	05h	Minimum cycle time [ns]	U32	RO	No	-	0003 D090h (250,000 ns)		-
	06h	Calc and copy time [ns]	U32	RO	No	-	0001 86A0h (100,000 ns)		-
	07h	Reserved	U32	-	-	-	-	-	-
	08h	Reserved	U16	-	-	-	-	-	-
	09h	Delay time [ns]	U32	RO	No	-	0	-	-
	0Ah to 1Fh	Reserved	U16	-	-	-	-	-	-
20h	Sync error	BOOL	RO	No	-	0	-	-	
1C33h	Sync manager 3 synchronization								
	00h	Number of entries	U8	RO	No	-	20h	-	-
	01h	Synchronization type	U16	RW	No	-	22h	00h: Free run mode (asynchronous) 02h: DC mode (SYNC0 event synchronization) 22h: Sync manager 2 event synchronization mode	A
	02h	Cycle time [ns]	U32	RO	No	-	-	-	-
	03h	Shift time [ns]	U32	RO	No	-	0	-	-
	04h	Synchronization types supported	U16	RO	No	-	0007h	-	-
	05h	Minimum cycle time [ns]	U32	RO	No	-	0003 D090h (250,000 ns)		-
	06h	Calc and copy time [ns]	U32	RO	No	-	0002 49F0h (150,000 ns)		-
	07h	Reserved	U32	-	-	-	-	-	-
	08h	Reserved	U16	-	-	-	-	-	-
	09h	Delay time [ns]	U32	RO	No	-	0	-	-
	0Ah to 1Fh	Reserved	U16	-	-	-	-	-	-
20h	Sync error	BOOL	RO	No	-	0	-	-	

2 Objects of the profile area

Objects in the profile area are defined by the CiA402 drive profile. Operations of the driver are set, and the status is indicated.

Index	Sub	Name	Type	Access	PDO	Save	Initial value	Range	Update
603Fh	00h	Error code	U16	RO	TxPDO	–	–	–	–
6040h	00h	Controlword	U16	RW	RxPDO	–	0	0 to FFFFh	A
6041h	00h	Statusword	U16	RO	TxPDO	–	–	–	–
605Ah	00h	Quick stop option code	INT16	RW	No	○	2	0, 1, 2, 3, 5, 6, 7	A
605Bh	00h	Shutdown option code	INT16	RW	No	○	1	0, 1	A
605Ch	00h	Disable operation option code	INT16	RW	No	○	1	0, 1	A
605Dh	00h	Halt option code	INT16	RW	No	○	1	1 to 3	A
6060h	00h	Modes of operation	INT8	RW	RxPDO	○	0	0: Operation function disable 1: Profile position mode (PP) 3: Profile velocity mode (PV) 6: Homing mode (HM) 8: Cyclic synchronous position mode (CSP) 9: Cyclic synchronous velocity mode (CSV)	B
6061h	00h	Modes of operation display	INT8	RO	TxPDO	–	–	–	–
6062h	00h	Position demand value [step]	INT32	RO	TxPDO	–	–	–	–
6064h	00h	Position actual value [step]	INT32	RO	TxPDO	–	–	–	–
6065h	00h	Following error window [1=0.01 rev]	U32	RW	No	○	300	1 to 30,000	A
6067h	00h	Position window [1=0.1°]	U32	RW	No	○	18	0 to 180	A
606Bh	00h	Velocity demand value [Hz]	INT32	RO	TxPDO	–	–	–	–
606Ch	00h	Velocity actual value [Hz]	INT32	RO	TxPDO	–	–	–	–
607Ah	00h	Target position [step]	INT32	RW	RxPDO	–	0	–2,147,483,648 to 2,147,483,647	A
607Ch	00h	Home offset [step]	INT32	RW	No	○	0	–2,147,483,648 to 2,147,483,647	A
607Dh	Software position limit								
	00h	Number of entries	U8	RO	No	–	2	–	–
	01h	Min. position limit [step]	INT32	RW	No	○	–2,147,483,648	–2,147,483,648 to 2,147,483,647	A
	02h	Max. position limit [step]	INT32	RW	No	○	2,147,483,647	–2,147,483,648 to 2,147,483,647	A
607Fh	00h	Max profile velocity [Hz]	U32	RW	RxPDO	○	1,000,000	0 to 4,000,000	B
6081h	00h	Profile velocity [Hz]	U32	RW	RxPDO	○	10,000	0 to 4,000,000	A
6083h	00h	Profile acceleration [step/s ²]	U32	RW	RxPDO	○	300,000	1 to 1,000,000,000	B
6084h	00h	Profile deceleration [step/s ²]	U32	RW	RxPDO	○	300,000	1 to 1,000,000,000	B
6085h	00h	Quick stop deceleration [step/s ²]	U32	RW	RxPDO	○	1,000,000	1 to 1,000,000,000	B
6091h	Gear ratio								
	00h	Number of entries	U8	RO	No	–	2	–	–
	01h	Electronic gear A	U32	RW	No	○	1	1 to 65,535	C
	02h	Electronic gear B	U32	RW	No	○	1	1 to 65,535	C
6098h	00h	Homing method	INT8	RW	No	○	24	–1, 17, 18, 24, 28, 35, 37	B
6099h	Homing speed								
	00h	Number of entries	U8	RO	No	–	2	–	–
	01h	Speed during search for switch [Hz]	U32	RW	No	○	10,000	1 to 4,000,000	B
	02h	Speed during search for zero [Hz]	U32	RW	No	○	5,000	1 to 10,000	B
609Ah	00h	Homing acceleration [step/s ²]	U32	RW	No	○	300,000	1 to 1,000,000,000	B
60B8h	00h	Touch probe function	U16	RW	RxPDO	–	0000h	0000h to FFFFh	A
60B9h	00h	Touch probe status	U16	RO	TxPDO	–	–	–	–
60BAh	00h	Touch probe position 1 positive value [step]	INT32	RO	TxPDO	–	–	–	–
60BBh	00h	Touch probe position 1 negative value [step]	INT32	RO	TxPDO	–	–	–	–
60BCh	00h	Touch probe position 2 positive value [step]	INT32	RO	TxPDO	–	–	–	–
60BDh	00h	Touch probe position 2 negative value [step]	INT32	RO	TxPDO	–	–	–	–

Objects of the profile area

Index	Sub	Name	Type	Access	PDO	Save	Initial value	Range	Update
Supported homing methods									
60E3h	00h	Number of entries	U8	RO	No	–	7	–	–
	01h	1st supported homing method	INT8	RO	No	–	17	–	–
	02h	2nd supported homing method	INT8	RO	No	–	18	–	–
	03h	3rd supported homing method	INT8	RO	No	–	24	–	–
	04h	4th supported homing method	INT8	RO	No	–	28	–	–
	05h	5th supported homing method	INT8	RO	No	–	35	–	–
	06h	6th supported homing method	INT8	RO	No	–	37	–	–
	07h	7th supported homing method	INT8	RO	No	–	–1	–	–
60F4h	00h	Following error actual value [step]	INT32	RO	TxPDO	–	0	–	–
60FDh	00h	Digital inputs	U32	RO	TxPDO	–	–	–	–
Digital outputs									
60FEh	00h	Number of entries	U8	RO	No	–	2	–	–
	01h	Physical outputs	U32	RW	RxPDO	–	0000 0000h	0000 0000h to FFFF FFFFh	A
	02h	Bit mask	U32	RW	No	–	0000 0000h	0000 0000h to FFFF FFFFh	A
60FFh	00h	Target velocity [Hz]	INT32	RW	RxPDO	–	0	–4,000,000 to 4,000,000	A
6502h	00h	Supported drive modes	U32	RO	No	–	0000 01A5h	–	–
67FFh	00h	Device profile number	U32	RO	No	–	0004 0192h	–	–

3 Objects of the manufacturer-specific area

These are our specific objects.

Refer to the **AZ** Series OPERATING MANUAL Function Edition for details of each object.

When checking the **AZ** Series OPERATING MANUAL Function Edition, use the object name instead of the Index.

Index	Sub	Name	Type	Access	PDO	Save	Initial value	Range	Update
4020h	00h	Backup DATA access key	INT32	RW	No	–	0	Key code: 20519253 (01391955h)	A
4021h	00h	Backup DATA write key	INT32	RW	No	–	0	Key code: 1977326743 (75DB9C97h)	A
403Eh	00h	Driver input command	U16	RW	RxPDO	–	0	0000h to FFFFh	A
403Fh	00h	Driver output status	U16	RO	TxPDO	–	–		
4040h	00h	Present alarm	U16	RO	TxPDO	–	–		
4041h	00h	Alarm history 1	U16	RO	No	–	–		
4042h	00h	Alarm history 2	U16	RO	No	–	–		
4043h	00h	Alarm history 3	U16	RO	No	–	–		
4044h	00h	Alarm history 4	U16	RO	No	–	–		
4045h	00h	Alarm history 5	U16	RO	No	–	–		
4046h	00h	Alarm history 6	U16	RO	No	–	–		
4047h	00h	Alarm history 7	U16	RO	No	–	–		
4048h	00h	Alarm history 8	U16	RO	No	–	–		
4049h	00h	Alarm history 9	U16	RO	No	–	–		
404Ah	00h	Alarm history 10	U16	RO	No	–	–		
4064h	00h	Command speed [r/min]	INT32	RO	TxPDO	–	–		
4067h	00h	Feedback speed [r/min]	INT32	RO	TxPDO	–	–		
406Ah	00h	Direct I/O	U32	RO	TxPDO	–	–		
406Bh	00h	Torque monitor [1=0.1 %]	INT16	RO	TxPDO	–	–		
406Dh	00h	Cumulative load monitor	INT32	RO	TxPDO	–	–		
407Bh	00h	Information	INT32	RO	TxPDO	–	–		
407Ch	00h	Driver temperature [1=0.1 °C]	INT16	RO	TxPDO	–	–		
407Dh	00h	Motor temperature [1=0.1 °C]	INT16	RO	TxPDO	–	–		
407Eh	00h	Odometer [1=0.1 kRev]	INT32	RO	TxPDO	–	–		
407Fh	00h	Tripmeter [1=0.1 kRev]	INT32	RO	TxPDO	–	–		
4090h	00h	Feedback position 32-bit counter	INT32	RO	TxPDO	–	–		
4091h	00h	Command position 32-bit counter	INT32	RO	TxPDO	–	–		
4092h	00h	CST operating current [1=0.1 %]	INT16	RO	TxPDO	–	–		
40A0h	00h	Main power supply count	INT32	RO	TxPDO	–	–		
40A1h	00h	Main power supply time [min]	INT32	RO	TxPDO	–	–		
40A2h	00h	Control power supply count	INT32	RO	TxPDO	–	–		
40A3h	00h	Inverter voltage [1=0.1 V]	INT16	RO	TxPDO	–	–		
40A4h	00h	Main power voltage [1=0.1 V]	INT16	RO	TxPDO	–	–		
40A9h	00h	Elapsed time from BOOT [ms]	INT32	RO	TxPDO	–	–		
40B7h	00h	Operation voltage mode [V]	U8	RO	TxPDO	–	–		
40B8h	00h	I/O status 1	U32	RO	TxPDO	–	–		
40B9h	00h	I/O status 2	U32	RO	TxPDO	–	–		
40BAh	00h	I/O status 3	U32	RO	TxPDO	–	–		
40BBh	00h	I/O status 4	U32	RO	TxPDO	–	–		
40BCh	00h	I/O status 5	U32	RO	TxPDO	–	–		
40BDh	00h	I/O status 6	U32	RO	TxPDO	–	–		
40BEh	00h	I/O status 7	U32	RO	TxPDO	–	–		
40BFh	00h	I/O status 8	U32	RO	TxPDO	–	–		

Objects of the manufacturer-specific area

Index	Sub	Name	Type	Access	PDO	Save	Initial value	Range	Update
40C0h	00h	Alarm reset	U8	RW	No	–	0	0: Not executed. 1: A command is executed when the data changes from 0 to 1. 2: A command is executed. It will automatically return to 1 after executing.	–
40C2h	00h	Clear alarm history	U8	RW	No	–	0		
40C5h	00h	P-PRESET execution	U8	RW	No	–	0		
40C6h	00h	Configuration	U8	RW	No	–	0		
40C8h	00h	Read batch NV memory	U8	RW	No	–	0		
40C9h	00h	Write batch NV memory	U8	RW	No	–	0		
40CAh	00h	All data initialization	U8	RW	No	–	0		
40CBh	00h	Read from backup	U8	RW	No	–	0		
40CCh	00h	Write to backup	U8	RW	No	–	0		
40CDh	00h	Clear latch information	U8	RW	No	–	0		
40CFh	00h	Clear tripmeter	U8	RW	No	–	0		
40D0h	00h	Execute ETO-CLR input	U8	RW	No	–	0		
40D1h	00h	ZSG-PRESET	U8	RW	No	–	0		
40D2h	00h	Clear ZSG-PRESET	U8	RW	No	–	0		
40D3h	00h	Clear information	U8	RW	No	–	0		
40D4h	00h	Clear information history	U8	RW	No	–	0		
4120h	00h	Operating current	INT16	RW	RxPDO	○	1,000	0 to 1,000 (1=0.1 %)	A*1
4121h	00h	Push current	INT16	RW	RxPDO	○	200	0 to 1,000 (1=0.1 %)	A*1
4126h	00h	Base current	INT16	RW	RxPDO	○	1,000	0 to 1,000 (1=0.1 %)	A
4128h	00h	Stop current	INT16	RW	RxPDO	○	500	0 to 1,000 (1=0.1 %)	A
4129h	00h	Command filter setting	INT8	RW	No	○	1	1: LPF (speed filter) 2: Moving average filter	B
412Ah	00h	Command filter time constant	INT16	RW	RxPDO	○	1	0 to 200 ms	B
412Ch	00h	Smooth drive function	U8	RW	No	○	1	0: Disable 1: Enable	C
412Dh	00h	Current control mode	U8	RW	No	○	0	0: The setting of the CCM input is followed 1: a control mode (CST) 2: Servo emulation mode (SVE)	A
412Eh	00h	Servo emulation (SVE) ratio	INT16	RW	No	○	1,000	0 to 1,000 (1=0.1 %)	A
412Fh	00h	SVE position loop gain	INT16	RW	No	○	10	1 to 50	A
4130h	00h	SVE speed loop gain	INT16	RW	No	○	180	10 to 200	A
4131h	00h	SVE speed loop integral time constant	INT16	RW	No	○	1,000	100 to 2,000 (1=0.1 ms)	A
4132h	00h	Automatic current cutback function	U8	RW	No	○	1	0: Disable 1: Enable	A
4133h	00h	Automatic current cutback switching time	INT16	RW	No	○	100	0 to 1,000 ms	A
4134h	00h	Operating current ramp up rate	U8	RW	No	○	0	0 to 100 (ms/100 %)	A
4135h	00h	Operating current ramp down rate	U8	RW	No	○	0	0 to 100 (ms/100 %)	A
4136h	00h	Electronic damper function	INT8	RW	No	○	1	0: Disable 1: Enable	A
4137h	00h	Resonance suppression control frequency	INT16	RW	No	○	1,000	100 to 2,000 Hz	A
4138h	00h	Resonance suppression control gain	INT16	RW	No	○	0	–500 to 500	A
4139h	00h	Deviation acceleration suppressing gain	INT16	RW	No	○	45	0 to 500	A
413Ah	00h	Filter time constant of torque monitor	U8	RW	No	○	0	0 to 200 ms	B
413Ch	00h	Current setting during push-motion	U8	RW	No	○	0	0: Push current 1: Operating current	A
413Dh	00h	Non-excitation mode selection	U8	RW	No	○	0	0: Dynamic brake status 1: Free-run status	A
4142h	00h	Starting speed	INT32	RW	RxPDO	○	5,000	0 to 4,000,000 Hz	B
4148h	00h	Permission of absolute positioning without setting absolute coordinates	U8	RW	No	○	0	0: Disable 1: Enable	B
414Fh	00h	Wrap positioning mode	U8	RW	RxPDO	○	0	0: Wrap absolute positioning 1: Wrap proximity 2: Wrap forward direction 3: Wrap reverse direction	B

Index	Sub	Name	Type	Access	PDO	Save	Initial value	Range	Update
4151h	00h	(JOG) Operating speed	INT32	RW	No	○	10,000	1 to 4,000,000 Hz	B
4152h	00h	(JOG) Acceleration/deceleration	INT32	RW	No	○	300,000	1 to 1,000,000,000 kHz/s	B
4153h	00h	(JOG) Starting speed	INT32	RW	No	○	5,000	0 to 4,000,000 Hz	B
4154h	00h	(JOG) Operating speed (high)	INT32	RW	No	○	50,000	1 to 4,000,000 Hz	B
4158h	00h	(ZHOME) Operating speed	INT32	RW	No	○	50,000	1 to 4,000,000 Hz	B
4159h	00h	(ZHOME) Acceleration/deceleration	INT32	RW	No	○	300,000	1 to 1,000,000,000 kHz/s	B
415Ah	00h	(ZHOME) Starting speed	INT32	RW	No	○	5,000	0 to 4,000,000 Hz	B
415Eh	00h	JOG/HOME/ZHOME command filter time constant	INT16	RW	No	○	1	1 to 200 ms	B
415Fh	00h	JOG/HOME/ZHOME operating current	INT16	RW	No	○	1,000	0 to 1,000 (1=0.1 %)	B
4160h	00h	(HOME) Home-seeking mode	U8	RW	No	○	1	0: 2-sensor 1: 3-sensor 2: One-way rotation 3: Push-motion	B
4161h	00h	(HOME) Starting direction	U8	RW	No	○	1	0: Negative side 1: Positive side	B
4163h	00h	(HOME) Starting speed	INT32	RW	No	○	5,000	1 to 4,000,000 Hz	B
4166h	00h	(HOME) SLIT detection	U8	RW	No	○	0	0: Disable 1: Enable	B
4167h	00h	(HOME) TIM/ZSG signal detection	U8	RW	No	○	0	0: Disable 1: TIM 2: ZSG	B
4168h	00h	(HOME) Position offset	INT32	RW	No	○	0	-2,147,483,647 to 2,147,483,647 steps	B
4169h	00h	(HOME) Backward steps in 2 sensor home-seeking	INT32	RW	No	○	5,000	0 to 8,388,607 steps	B
416Ah	00h	(HOME) Operating amount in uni-directional home-seeking	INT32	RW	No	○	5,000	0 to 8,388,607 steps	B
416Bh	00h	(HOME) Operating current for push-home-seeking	INT16	RW	No	○	1,000	0 to 1,000 (1=0.1 %)	B
416Ch	00h	(HOME) Backward steps after first entry in push-home-seeking	INT32	RW	No	○	0	0 to 8,388,607 steps	B
416Dh	00h	(HOME) Pushing time in push-home-seeking	U16	RW	No	○	200	1 to 65,535 ms	B
416Eh	00h	(HOME) Backward steps in push-home-seeking	INT32	RW	No	○	5,000	0 to 8,388,607 steps	B
4180h	00h	Overload alarm	INT16	RW	No	○	50	1 to 300 (1=0.1 s)	A
4190h	00h	HWTO mode selection	U8	RW	No	○	0	0: Alarm is not present 1: Alarm is present	A
4191h	00h	HWTO delay time of checking dual system	U8	RW	No	○	0	0 to 10 (disable), 11 to 100 ms	A
4198h	00h	ETO reset ineffective period	U8	RW	No	○	0	0 to 100 ms	A
4199h	00h	ETO reset action (ETO-CLR)	U8	RW	No	○	1	1: Activate at ON edge 2: Activate at ON level	A
419Ah	00h	ETO reset action (ALM-RST)	U8	RW	No	○	0	0: Disable 1: Activate at ON edge	A
419Ch	00h	ETO reset action (STOP)	U8	RW	No	○	1	0: Disable 1: Activate at ON edge	A
41A0h	00h	Driver temperature information (INFO-DRVTMP)	INT16	RW	RxPDO	○	85	40 to 85 °C	A
41A1h	00h	Overload time information (INFO-OLTIME)	INT16	RW	RxPDO	○	50	1 to 300 (1=0.1 s)	A
41A2h	00h	Speed information (INFO-SPD)	INT16	RW	RxPDO	○	0	0: Disable 1 to 12,000 r/min	A
41A5h	00h	Position deviation information (INFO-POSERR)	INT16	RW	RxPDO	○	300	1 to 30,000 (1=0.01 rev)	A
41A8h	00h	Motor temperature information (INFO-MTRTMP)	INT16	RW	RxPDO	○	85	40 to 120 °C	A
41A9h	00h	Overvoltage information (INFO-OVOLT) [AC power input type driver]	INT16	RW	RxPDO	○	435	120 to 450 V	A
41AAh	00h	Undervoltage information (INFO-UVOLT) [AC power input type driver]	INT16	RW	RxPDO	○	120	120 to 280 V	A

Objects of the manufacturer-specific area

Index	Sub	Name	Type	Access	PDO	Save	Initial value	Range	Update
41ABh	00h	Overvoltage information (INFO-OVOLT) [DC power input type driver]	INT16	RW	RxPDO	○	630	150 to 630 (1=0.1 V)	A
41ACh	00h	Undervoltage information (INFO-UVOLT) [DC power input type driver]	INT16	RW	RxPDO	○	180	150 to 630 (1=0.1 V)	A
41AFh	00h	Tripmeter information (INFO-TRIP)	INT32	RW	RxPDO	○	0	0: Disable 1 to 2,147,483,647 (1=0.1 kRev)	A
41B0h	00h	Odometer information (INFO-ODO)	INT32	RW	RxPDO	○	0	0: Disable 1 to 2,147,483,647 (1=0.1 kRev)	A
41B1h	00h	Cumulative load 0 information (INFO-CULD0)	INT32	RW	RxPDO	○	0	0 to 2,147,483,647	A
41B2h	00h	Cumulative load 1 information (INFO-CULD1)	INT32	RW	RxPDO	○	0	0 to 2,147,483,647	A
41B3h	00h	Cumulative load value auto clear	U8	RW	No	○	1	0: Disable 1: Enable	A
41B4h	00h	Cumulative load value count divisor	U16	RW	No	○	1	1 to 32,767	A
41BCh	00h	INFO-USRIO output selection	U8	RW	No	○	128	Output signals list ⇨ p.160	A
41BDh	00h	INFO-USRIO output inversion	U8	RW	No	○	0	0: Not invert 1: Invert	A
41BEh	00h	Information LED condition	U8	RW	No	○	1	0: Disable (LED does not blink) 1: Enable (LED blinks)	A
41BFh	00h	Information auto clear	U8	RW	No	○	1	0: Disable (not turned OFF automatically) 1: Enable (turned OFF automatically)	A
41C2h	00h	Motor rotation direction	U8	RW	No	○	1	0: Positive side=Counterclockwise 1: Positive side=Clockwise 2: Positive side=Counterclockwise (the driver parameter is applied) 3: Positive side=Clockwise (the driver parameter is applied)	C
41C3h	00h	Software overtravel	INT8	RW	No	○	3	-1: Disable 0: Immediate stop 1: Deceleration stop 2: Immediate stop with alarm 3: Deceleration stop with alarm	A
41C6h	00h	Preset position	INT32	RW	No	○	0	-2,147,483,648 to 2,147,483,647 steps	A
41C7h	00h	Wrap setting	U8	RW	No	○	1	0: Disable 1: Enable	C
41C9h	00h	Initial coordinate generation & wrap setting range	INT32	RW	No	○	10	5 to 655,360 (1=0.1 rev)	C
41CBh	00h	Initial coordinate generation & wrap range offset ratio	U16	RW	No	○	5,000	0 to 10,000 (1=0.01 %)	C
41CCh	00h	Initial coordinate generation & wrap range offset value	INT32	RW	No	○	0	-536,870,912 to 536,870,911 steps	C
41CDh	00h	The number of the RND-ZERO output in wrap range	INT32	RW	No	○	1	1 to 536,870,911	C
41F0h	00h	PULSE-I/F mode selection	INT8	RW	No	○	1	-1: Disable 1: 2 pulse input mode 2: 1 pulse input mode 3: Phase-shifted pulses input mode (x1) 4: Phase-shifted pulses input mode (x2) 5: Phase-shifted pulses input mode (x4)	D
41FAh	00h	Main power mode*2	INT8	RW	No	○	-1	-1: Automatic discrimination 0: 24 VDC 1: 48 VDC	D
41FFh	00h	Drive simulation mode	U8	RW	No	○	0	0: Use real motor 1: Virtual motor (when ABZO not connected=no ABZO information) 2: Virtual motor (when ABZO not connected=1,800 rev wrap enable) 3: Virtual motor (when ABZO not connected=900 rev wrap enable)	D

Index	Sub	Name	Type	Access	PDO	Save	Initial value	Range	Update
44B0h	00h	Touch probe 1 latch position	U8	RW	No	○	0	0: Latches the feedback position 1: Latches the command position	A
44B1h	00h	Touch probe 2 latch position	U8	RW	No	○	0		
44B2h	00h	Touch probe 1 TIM/ZSG signal select	U8	RW	No	○	0	0: Latch on the ZSG output 1: Latch on the TIM output	A
44B3h	00h	Touch probe 2 TIM/ZSG signal select	U8	RW	No	○	0		
4510h	00h	Information history 1	INT32	RO	No	–	–	–	–
4511h	00h	Information history 2	INT32	RO	No	–	–		
4512h	00h	Information history 3	INT32	RO	No	–	–		
4513h	00h	Information history 4	INT32	RO	No	–	–		
4514h	00h	Information history 5	INT32	RO	No	–	–		
4515h	00h	Information history 6	INT32	RO	No	–	–		
4516h	00h	Information history 7	INT32	RO	No	–	–		
4517h	00h	Information history 8	INT32	RO	No	–	–		
4518h	00h	Information history 9	INT32	RO	No	–	–		
4519h	00h	Information history 10	INT32	RO	No	–	–		
451Ah	00h	Information history 11	INT32	RO	No	–	–		
451Bh	00h	Information history 12	INT32	RO	No	–	–		
451Ch	00h	Information history 13	INT32	RO	No	–	–		
451Dh	00h	Information history 14	INT32	RO	No	–	–		
451Eh	00h	Information history 15	INT32	RO	No	–	–		
451Fh	00h	Information history 16	INT32	RO	No	–	–		
4520h	00h	Information time history 1	INT32	RO	No	–	–	–	–
4521h	00h	Information time history 2	INT32	RO	No	–	–		
4522h	00h	Information time history 3	INT32	RO	No	–	–		
4523h	00h	Information time history 4	INT32	RO	No	–	–		
4524h	00h	Information time history 5	INT32	RO	No	–	–		
4525h	00h	Information time history 6	INT32	RO	No	–	–		
4526h	00h	Information time history 7	INT32	RO	No	–	–		
4527h	00h	Information time history 8	INT32	RO	No	–	–		
4528h	00h	Information time history 9	INT32	RO	No	–	–		
4529h	00h	Information time history 10	INT32	RO	No	–	–		
452Ah	00h	Information time history 11	INT32	RO	No	–	–		
452Bh	00h	Information time history 12	INT32	RO	No	–	–		
452Ch	00h	Information time history 13	INT32	RO	No	–	–		
452Dh	00h	Information time history 14	INT32	RO	No	–	–		
452Eh	00h	Information time history 15	INT32	RO	No	–	–		
452Fh	00h	Information time history 16	INT32	RO	No	–	–		
4642h	00h	Driver CPU number	U16	RO	No	–	–	–	–
4643h	00h	Driver software version	U16	RO	No	–	–	–	–
4700h	00h	STOP input action	INT8	RW	No	○	3	0: Immediate stop 3: Deceleration stop	A
4701h	00h	FW-LS/RV-LS input action	INT8	RW	No	○	2	–1: Used as a return-to-home sensor 0: Immediate stop 1: Deceleration stop 2: Immediate stop with alarm 3: Deceleration stop with alarm	A
4702h	00h	FW-BLK/RV-BLK input action	INT8	RW	No	○	0	0: Immediate stop 1: Deceleration stop	A
4704h	00h	IN-POS positioning completion signal offset	INT16	RW	No	○	0	–18 to 18 (1=0.1°)	A
4707h	00h	ZSG signal width	U16	RW	No	○	18	1 to 1,800 (1=0.1°)	A
4708h	00h	RND-ZERO signal width	U16	RW	No	○	10	1 to 10,000 steps	A
4709h	00h	RND-ZERO signal source	U8	RW	No	○	0	0: Based on feedback position 1: Based on command position	A
470Ah	00h	MOVE minimum ON time	U8	RW	No	○	0	0 to 255 ms	A
470Ch	00h	PLS-XMODE pulse multiplying factor	INT8	RW	No	○	10	2 to 30 times	A
470Dh	00h	CRNT-LMT operating current limit value	INT16	RW	No	○	500	0 to 1,000 (1=0.1 %)	A

Objects of the manufacturer-specific area

Index	Sub	Name	Type	Access	PDO	Save	Initial value	Range	Update
470Eh	00h	SPD-LMT speed limit type selection	INT8	RW	No	○	0	0: Ratio 1: Value	A
470Fh	00h	SPD-LMT speed limit ratio	INT8	RW	No	○	50	1 to 100 %	A
4710h	00h	SPD-LMT speed limit value	INT32	RW	No	○	10,000	1 to 4,000,000 Hz	A
4713h	00h	PLS-LOST check algorithm	U8	RW	No	○	0	0: Unsigned 1: Signed	A
4718h	00h	VA mode selection	U8	RW	No	○	2	0: Feedback speed attainment (speed at feedback position) 1: Speed at command position (only internal profile) 2: Speed at feedback position & command position (only internal profile)	A
4719h	00h	VA detection speed range	U8	RW	No	○	30	1 to 200 r/min	B
4740h	00h	AREA0 positive direction position/ offset	INT32	RW	No	○	0	-2,147,483,648 to 2,147,483,647 steps	A
4741h	00h	AREA0 negative direction position/ detection range	INT32	RW	No	○	0		
4742h	00h	AREA1 positive direction position/ offset	INT32	RW	No	○	0		
4743h	00h	AREA1 negative direction position/ detection range	INT32	RW	No	○	0		
4744h	00h	AREA2 positive direction position/ offset	INT32	RW	No	○	0		
4745h	00h	AREA2 negative direction position/ detection range	INT32	RW	No	○	0		
4746h	00h	AREA3 positive direction position/ offset	INT32	RW	No	○	0		
4747h	00h	AREA3 negative direction position/ detection range	INT32	RW	No	○	0		
4748h	00h	AREA4 positive direction position/ offset	INT32	RW	No	○	0		
4749h	00h	AREA4 negative direction position/ detection range	INT32	RW	No	○	0		
474Ah	00h	AREA5 positive direction position/ offset	INT32	RW	No	○	0		
474Bh	00h	AREA5 negative direction position/ detection range	INT32	RW	No	○	0		
474Ch	00h	AREA6 positive direction position/ offset	INT32	RW	No	○	0		
474Dh	00h	AREA6 negative direction position/ detection range	INT32	RW	No	○	0		
474Eh	00h	AREA7 positive direction position/ offset	INT32	RW	No	○	0	0: Absolute pos 1: Offset/width setting from the target position	A
474Fh	00h	AREA7 negative direction position/ detection range	INT32	RW	No	○	0		
4750h	00h	AREA0 range setting mode	U8	RW	No	○	0		
4751h	00h	AREA1 range setting mode	U8	RW	No	○	0		
4752h	00h	AREA2 range setting mode	U8	RW	No	○	0		
4753h	00h	AREA3 range setting mode	U8	RW	No	○	0		
4754h	00h	AREA4 range setting mode	U8	RW	No	○	0		
4755h	00h	AREA5 range setting mode	U8	RW	No	○	0	0: Based on feedback position 1: Based on command position	A
4756h	00h	AREA6 range setting mode	U8	RW	No	○	0		
4757h	00h	AREA7 range setting mode	U8	RW	No	○	0		
4758h	00h	AREA0 positioning standard	U8	RW	No	○	0		
4759h	00h	AREA1 positioning standard	U8	RW	No	○	0		
475Ah	00h	AREA2 positioning standard	U8	RW	No	○	0		
475Bh	00h	AREA3 positioning standard	U8	RW	No	○	0		
475Ch	00h	AREA4 positioning standard	U8	RW	No	○	0		
475Dh	00h	AREA5 positioning standard	U8	RW	No	○	0		
475Eh	00h	AREA6 positioning standard	U8	RW	No	○	0		
475Fh	00h	AREA7 positioning standard	U8	RW	No	○	0		

Index	Sub	Name	Type	Access	PDO	Save	Initial value	Range	Update
47A0h	00h	INFO action (Assigned I/O status information (INFO-USRIO))	U8	RW	No	○	1	0: No Info reflect Only the bit output is ON. 1: Info reflect The bit output and the INFO output are ON and the LED blinks.	A
47A1h	00h	INFO action (Position deviation information (INFO-POSERR))	U8	RW	No	○	1		
47A2h	00h	INFO action (Driver temperature information (INFO-DRVTMP))	U8	RW	No	○	1		
47A3h	00h	INFO action (Motor temperature information (INFO-MTRTMP))	U8	RW	No	○	1		
47A4h	00h	INFO action (Overvoltage information (INFO-OVOLT))	U8	RW	No	○	1		
47A5h	00h	INFO action (Undervoltage information (INFO-UVOLT))	U8	RW	No	○	1		
47A6h	00h	INFO action (Overload time information (INFO-OLTIME))	U8	RW	No	○	1		
47A8h	00h	INFO action (Speed information (INFO-SPD))	U8	RW	No	○	1		
47A9h	00h	INFO action (Start operation error information (INFO-START))	U8	RW	No	○	1		
47AAh	00h	INFO action (Start ZHOME error information (INFO-ZHOME))	U8	RW	No	○	1		
47ABh	00h	INFO action (PRESET request information (INFO-PR-REQ))	U8	RW	No	○	1		
47ADh	00h	INFO action (Electronic gear setting error information (INFO-EGR-E))	U8	RW	No	○	1		
47AEh	00h	INFO action (Wrap setting error information (INFO-RND-E))	U8	RW	No	○	1		
47B0h	00h	INFO action (Forward operation prohibiton information (INFO-FW-OT))	U8	RW	No	○	1		
47B1h	00h	INFO action (Reverse operation prohibiton information (INFO-RV-OT))	U8	RW	No	○	1		
47B2h	00h	INFO action (Cumulative load 0 information (INFO-CULD0))	U8	RW	No	○	1		
47B3h	00h	INFO action (Cumulative load 1 information (INFO-CULD1))	U8	RW	No	○	1		
47B4h	00h	INFO action (Tripmeter information (INFO-TRIP))	U8	RW	No	○	1		
47B5h	00h	INFO action (Odometer information (INFO-ODO))	U8	RW	No	○	1		
47BCh	00h	INFO action (Start operation restricted mode information (INFO-DSLMTD))	U8	RW	No	○	1		
47BDh	00h	INFO action (I/O test mode information (INFO-IOTEST))	U8	RW	No	○	1		
47BEh	00h	INFO action (Configuration request information (INFO-CFG))	U8	RW	No	○	1		
47BFh	00h	INFO action (Reboot request information (INFO-RBT))	U8	RW	No	○	1		
47F0h	00h	Mechanism settings	U8	RW	No	○	1	0: Prioritize ABZO setting 1: Manual setting	D
47F1h	00h	Gear ratio setting	INT16	RW	No	○	0	0: Gear ratio setting disable 1 to 32,767: Gear ratio (1=0.01)	C
47F2h	00h	Initial coordinate generation & wrap coordinate setting	U8	RW	No	○	0	0: Prioritize ABZO setting 1: Manual setting	D
47F3h	00h	Mechanism limit parameter setting	U8	RW	No	○	0	0: Follow ABZO setting 1: Disable	D
47F4h	00h	Mechanism protection parameter setting	U8	RW	No	○	0	0: Follow ABZO setting 1: Disable	D
47F5h	00h	JOG/HOME/ZHOME operation setting	U8	RW	No	○	0	0: Prioritize ABZO setting 1: Manual setting	D

Objects of the manufacturer-specific area

Index	Sub	Name	Type	Access	PDO	Save	Initial value	Range	Update
4840h	00h	DIN0 input function	U8	RW	No	○	30	Input signal list ⇔ p.159	C
4841h	00h	DIN1 input function	U8	RW	No	○	1		
4842h	00h	DIN2 input function	U8	RW	No	○	12		
4843h	00h	DIN3 input function	U8	RW	No	○	104		
4844h	00h	DIN4 input function	U8	RW	No	○	28		
4845h	00h	DIN5 input function	U8	RW	No	○	29	0: Non invert 1: Invert	C
4850h	00h	DIN0 inverting mode	U8	RW	No	○	0		
4851h	00h	DIN1 inverting mode	U8	RW	No	○	0		
4852h	00h	DIN2 inverting mode	U8	RW	No	○	0		
4853h	00h	DIN3 inverting mode	U8	RW	No	○	0		
4854h	00h	DIN4 inverting mode	U8	RW	No	○	0	Output signal list ⇔ p.160	C
4855h	00h	DIN5 inverting mode	U8	RW	No	○	0		
4860h	00h	DOUT0 (Normal) output function	U8	RW	No	○	144		
4861h	00h	DOUT1 (Normal) output function	U8	RW	No	○	137		
4862h	00h	DOUT2 (Normal) output function	U8	RW	No	○	133		
4863h	00h	DOUT3 (Normal) output function	U8	RW	No	○	142	0: Non invert 1: Invert	C
4864h	00h	DOUT4 (Normal) output function	U8	RW	No	○	134		
4865h	00h	DOUT5 (Normal) output function	U8	RW	No	○	130		
4870h	00h	DOUT0 inverting mode	U8	RW	No	○	0		
4871h	00h	DOUT1 inverting mode	U8	RW	No	○	0		
4872h	00h	DOUT2 inverting mode	U8	RW	No	○	0	Input signal list ⇔ p.159	C
4873h	00h	DOUT3 inverting mode	U8	RW	No	○	0		
4874h	00h	DOUT4 inverting mode	U8	RW	No	○	0		
4875h	00h	DOUT5 inverting mode	U8	RW	No	○	0		
4880h	00h	DIN0 composite input function	U8	RW	No	○	0		
4881h	00h	DIN1 composite input function	U8	RW	No	○	0	Output signal list ⇔ p.160	C
4882h	00h	DIN2 composite input function	U8	RW	No	○	0		
4883h	00h	DIN3 composite input function	U8	RW	No	○	0		
4884h	00h	DIN4 composite input function	U8	RW	No	○	0		
4885h	00h	DIN5 composite input function	U8	RW	No	○	0		
4890h	00h	DOUT0 composite output function	U8	RW	No	○	128	0: Non invert 1: Invert	C
4891h	00h	DOUT1 composite output function	U8	RW	No	○	128		
4892h	00h	DOUT2 composite output function	U8	RW	No	○	128		
4893h	00h	DOUT3 composite output function	U8	RW	No	○	128		
4894h	00h	DOUT4 composite output function	U8	RW	No	○	128		
4895h	00h	DOUT5 composite output function	U8	RW	No	○	128	0: AND 1: OR	C
48A0h	00h	DOUT0 composite inverting mode	U8	RW	No	○	0		
48A1h	00h	DOUT1 composite inverting mode	U8	RW	No	○	0		
48A2h	00h	DOUT2 composite inverting mode	U8	RW	No	○	0		
48A3h	00h	DOUT3 composite inverting mode	U8	RW	No	○	0		
48A4h	00h	DOUT4 composite inverting mode	U8	RW	No	○	0	0 to 250 ms	C
48A5h	00h	DOUT5 composite inverting mode	U8	RW	No	○	0		
48B0h	00h	DOUT0 composite logical combination	U8	RW	No	○	1		
48B1h	00h	DOUT1 composite logical combination	U8	RW	No	○	1		
48B2h	00h	DOUT2 composite logical combination	U8	RW	No	○	1		
48B3h	00h	DOUT3 composite logical combination	U8	RW	No	○	1	0 to 250 ms	C
48B4h	00h	DOUT4 composite logical combination	U8	RW	No	○	1		
48B5h	00h	DOUT5 composite logical combination	U8	RW	No	○	1		
48C0h	00h	DIN0 ON signal dead-time	U8	RW	No	○	0		
48C1h	00h	DIN1 ON signal dead-time	U8	RW	No	○	0	0 to 250 ms	C
48C2h	00h	DIN2 ON signal dead-time	U8	RW	No	○	0		
48C3h	00h	DIN3 ON signal dead-time	U8	RW	No	○	0		

Index	Sub	Name	Type	Access	PDO	Save	Initial value	Range	Update
48C4h	00h	DIN4 ON signal dead-time	U8	RW	No	○	0	0 to 250 ms	C
48C5h	00h	DIN5 ON signal dead-time	U8	RW	No	○	0		
48D0h	00h	DIN0 1 shot signal	U8	RW	No	○	0	0: Disable 1: Enable	C
48D1h	00h	DIN1 1 shot signal	U8	RW	No	○	0		
48D2h	00h	DIN2 1 shot signal	U8	RW	No	○	0		
48D3h	00h	DIN3 1 shot signal	U8	RW	No	○	0		
48D4h	00h	DIN4 1 shot signal	U8	RW	No	○	0		
48D5h	00h	DIN5 1 shot signal	U8	RW	No	○	0		
48E0h	00h	DOUT0 OFF delay time	U8	RW	No	○	0	0 to 250 ms	C
48E1h	00h	DOUT1 OFF delay time	U8	RW	No	○	0		
48E2h	00h	DOUT2 OFF delay time	U8	RW	No	○	0		
48E3h	00h	DOUT3 OFF delay time	U8	RW	No	○	0		
48E4h	00h	DOUT4 OFF delay time	U8	RW	No	○	0		
48E5h	00h	DOUT5 OFF delay time	U8	RW	No	○	0		
4900h	00h	R-IN0 input function	U8	RW	No	○	0	Input signal list ⇨ p.159	C
4901h	00h	R-IN1 input function	U8	RW	No	○	0		
4902h	00h	R-IN2 input function	U8	RW	No	○	0		
4903h	00h	R-IN3 input function	U8	RW	No	○	0		
4904h	00h	R-IN4 input function	U8	RW	No	○	0		
4905h	00h	R-IN5 input function	U8	RW	No	○	0		
4906h	00h	R-IN6 input function	U8	RW	No	○	0		
4907h	00h	R-IN7 input function	U8	RW	No	○	0		
4908h	00h	R-IN8 input function	U8	RW	No	○	0		
4909h	00h	R-IN9 input function	U8	RW	No	○	0		
490Ah	00h	R-IN10 input function	U8	RW	No	○	0		
490Bh	00h	R-IN11 input function	U8	RW	No	○	0		
490Ch	00h	R-IN12 input function	U8	RW	No	○	0		
490Dh	00h	R-IN13 input function	U8	RW	No	○	0		
490Eh	00h	R-IN14 input function	U8	RW	No	○	0		
490Fh	00h	R-IN15 input function	U8	RW	No	○	0		
4910h	00h	R-OUT0 output function	U8	RW	No	○	28	Output signal list ⇨ p.160	C
4911h	00h	R-OUT1 output function	U8	RW	No	○	29		
4912h	00h	R-OUT2 output function	U8	RW	No	○	155		
4913h	00h	R-OUT3 output function	U8	RW	No	○	0		
4914h	00h	R-OUT4 output function	U8	RW	No	○	144		
4915h	00h	R-OUT5 output function	U8	RW	No	○	204		
4916h	00h	R-OUT6 output function	U8	RW	No	○	135		
4917h	00h	R-OUT7 output function	U8	RW	No	○	129		
4918h	00h	R-OUT8 output function	U8	RW	No	○	136		
4919h	00h	R-OUT9 output function	U8	RW	No	○	160		
491Ah	00h	R-OUT10 output function	U8	RW	No	○	161		
491Bh	00h	R-OUT11 output function	U8	RW	No	○	162		
491Ch	00h	R-OUT12 output function	U8	RW	No	○	157		
491Dh	00h	R-OUT13 output function	U8	RW	No	○	134		
491Eh	00h	R-OUT14 output function	U8	RW	No	○	138		
491Fh	00h	R-OUT15 output function	U8	RW	No	○	140		
4930h	00h	R-OUT0 OFF delay time	U8	RW	No	○	0	0 to 250 ms	C
4931h	00h	R-OUT1 OFF delay time	U8	RW	No	○	0		
4932h	00h	R-OUT2 OFF delay time	U8	RW	No	○	0		
4933h	00h	R-OUT3 OFF delay time	U8	RW	No	○	0		
4934h	00h	R-OUT4 OFF delay time	U8	RW	No	○	0		
4935h	00h	R-OUT5 OFF delay time	U8	RW	No	○	0		
4936h	00h	R-OUT6 OFF delay time	U8	RW	No	○	0		
4937h	00h	R-OUT7 OFF delay time	U8	RW	No	○	0		
4938h	00h	R-OUT8 OFF delay time	U8	RW	No	○	0		
4939h	00h	R-OUT9 OFF delay time	U8	RW	No	○	0		

Objects of the manufacturer-specific area

Index	Sub	Name	Type	Access	PDO	Save	Initial value	Range	Update
493Ah	00h	R-OUT10 OFF delay time	U8	RW	No	○	0	0 to 250 ms	C
493Bh	00h	R-OUT11 OFF delay time	U8	RW	No	○	0		
493Ch	00h	R-OUT12 OFF delay time	U8	RW	No	○	0		
493Dh	00h	R-OUT13 OFF delay time	U8	RW	No	○	0		
493Eh	00h	R-OUT14 OFF delay time	U8	RW	No	○	0		
493Fh	00h	R-OUT15 OFF delay time	U8	RW	No	○	0		
4940h	00h	Virtual input (VIR-IN0) function	U8	RW	No	○	0	Input signal list ⇔ p.159	C
4941h	00h	Virtual input (VIR-IN1) function	U8	RW	No	○	0		
4942h	00h	Virtual input (VIR-IN2) function	U8	RW	No	○	0		
4943h	00h	Virtual input (VIR-IN3) function	U8	RW	No	○	0		
4944h	00h	Virtual input (VIR-IN0) source selection	U8	RW	No	○	128	Output signal list ⇔ p.160	C
4945h	00h	Virtual input (VIR-IN1) source selection	U8	RW	No	○	128		
4946h	00h	Virtual input (VIR-IN2) source selection	U8	RW	No	○	128		
4947h	00h	Virtual input (VIR-IN3) source selection	U8	RW	No	○	128		
4948h	00h	Virtual input (VIR-IN0) inverting mode	U8	RW	No	○	0	0: Non invert 1: Invert	C
4949h	00h	Virtual input (VIR-IN1) inverting mode	U8	RW	No	○	0		
494Ah	00h	Virtual input (VIR-IN2) inverting mode	U8	RW	No	○	0		
494Bh	00h	Virtual input (VIR-IN3) inverting mode	U8	RW	No	○	0		
494Ch	00h	Virtual input (VIR-IN0) ON signal dead time [ms]	U8	RW	No	○	0	0 to 250 ms	C
494Dh	00h	Virtual input (VIR-IN1) ON signal dead time [ms]	U8	RW	No	○	0		
494Eh	00h	Virtual input (VIR-IN2) ON signal dead time [ms]	U8	RW	No	○	0		
494Fh	00h	Virtual input (VIR-IN3) ON signal dead time [ms]	U8	RW	No	○	0		
4950h	00h	Virtual input (VIR-IN0) 1 shot signal mode	U8	RW	No	○	0	0: Disable 1: Enable	C
4951h	00h	Virtual input (VIR-IN1) 1 shot signal mode	U8	RW	No	○	0		
4952h	00h	Virtual input (VIR-IN2) 1 shot signal mode	U8	RW	No	○	0		
4953h	00h	Virtual input (VIR-IN3) 1 shot signal mode	U8	RW	No	○	0		
4960h	00h	User output (USR-OUT0) source A function	U8	RW	No	○	128	Output signal list ⇔ p.160	C
4961h	00h	User output (USR-OUT1) source A function	U8	RW	No	○	128		
4962h	00h	User output (USR-OUT0) source A inverting mode	U8	RW	No	○	0	0: Non invert 1: Invert	C
4963h	00h	User output (USR-OUT1) source A inverting mode	U8	RW	No	○	0		
4964h	00h	User output (USR-OUT0) source B function	U8	RW	No	○	128	Output signal list ⇔ p.160	C
4965h	00h	User output (USR-OUT1) source B function	U8	RW	No	○	128		
4966h	00h	User output (USR-OUT0) source B inverting mode	U8	RW	No	○	0	0: Non invert 1: Invert	C
4967h	00h	User output (USR-OUT1) source B inverting mode	U8	RW	No	○	0		
4968h	00h	User output (USR-OUT0) logical operation	U8	RW	No	○	1	0: AND 1: OR	C
4969h	00h	User output (USR-OUT1) logical operation	U8	RW	No	○	1		
4970h	00h	Extended input (EXT-IN) function	U8	RW	No	○	9	Input signal list ⇔ p.159	C

Index	Sub	Name	Type	Access	PDO	Save	Initial value	Range	Update
4971h	00h	Extended input (EXT-IN) inverting mode	U8	RW	No	○	0	0: Non invert 1: Invert	C
4972h	00h	Extended input (EXT-IN) interlock releasing time	INT8	RW	No	○	10	0: Disable 1 to 50 (1=0.1s)	A
4973h	00h	Extended input (EXT-IN) interlock releasing duration	INT8	RW	No	○	30	0 to 50 (1=0.1s)	A
4974h	00h	Extended input (EXT-IN) ON monitor time	INT8	RW	No	○	10	0 to 50 (1=0.1s)	A
49FAh	00h	Current setting during motor standstill at T-MODE	INT32	RW	No	○	0	0: Stop current 1: Operating current	A

*1 With the profile position mode, it will be update at start of operation.

*2 This is the object for DC power input drivers. It is used to set the voltage mode of the main power supply.

■ Reference picture of ON signal dead-time [ms]

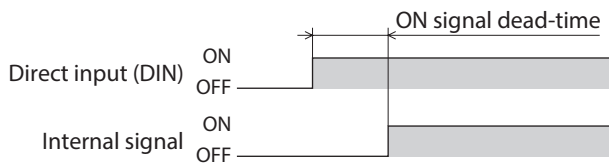

■ Reference picture of OFF output-delay time [ms]

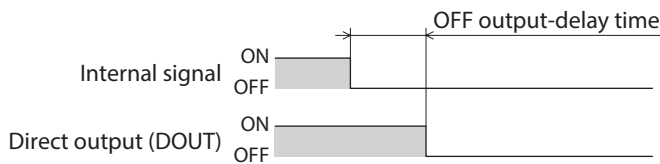

6 Troubleshooting

This part describes alarm and information functions.

◆ Table of contents

1	Alarms.....	218
1-1	Alarm reset.....	218
1-2	Alarm history.....	218
1-3	Generation condition of alarms.....	218
1-4	Alarm list.....	219
1-5	Timing chart.....	225
2	Information.....	227
2-1	Information history.....	229
2-2	Information list.....	229
3	Troubleshooting and remedial actions.....	233



1 Alarms

This driver has the alarm function to protect from temperature rise, poor connection, error in operation, and others. If an alarm is generated, the ALM-A output is turned ON and the ALM-B output is turned OFF to stop the motor. At the same time, the PWR/ALM LED blinks in red.

Details of the alarm being generated can be checked by counting the number of times the PWR/ALM LED blinks, or using EtherCAT communication or the **MEXE02**.

1-1 Alarm reset

Before resetting an alarm, always remove the cause of the alarm and ensure safety, and perform one of the reset operations specified next.

- Set the "Fault reset (6040h: bit7)" of the controlword to 1. (The alarm will be reset when changing from 0 to 1.)
- Set the "Alarm reset (40C0h)" via EtherCAT communication to 1. (The alarm will be reset when changing from 0 to 1.)
- Turn the ALM-RST input ON. (The alarm will be reset at the ON edge of the input.)
- Execute the alarm reset using the **MEXE02**.
- Turn on the control power supply again.



- Some alarms cannot be reset by other methods than turning on the control power supply again. Check with "1-4 Alarm list" on p.219.
- An alarm of the absolute position error can be reset if the position preset (P-PRESET) or return-to-home operation is performed. If it cannot be reset by these methods, the ABZO sensor may be damaged.

1-2 Alarm history

Up to 10 generated alarm items are stored in the non-volatile memory in order of the latest to oldest. The alarm history stored in the non-volatile memory can be read or cleared if one of the following is performed.

- Read the alarm history by the "Alarm history (4041h to 404Ah)" via EtherCAT communication.
- Clear the history by setting the "Clear alarm history (40C2h)" of EtherCAT communication to 1. (It is enabled when changing from 0 to 1.)
- Read and clear the alarm history using the **MEXE02**.

1-3 Generation condition of alarms

Alarms shown in the table will be generated if the generation condition is exceeded.

Alarm code	Alarm name	Motor model	Generation condition	
			AC power input driver	DC power input driver
21h	Main circuit overheat [°C (°F)]	–	85 (185)	85 (185)
22h	Overvoltage (V)	–	430	63
26h	Motor overheat [°C (°F)]	–	85 (185)	85 (185)
31h	Overspeed (r/min)	AZM14 AZM15 AZM24 AZM26	–	8,000
		AZM46 AZM48 AZM66	8,000	4,500
		AZM69	8,000	2,500
		AZM98 AZM911	5,000	–
34h	Command pulse error (r/min)	–	38,400	38,400

1-4 Alarm list



If an alarm is generated, the motor will put into a non-excitation state.

Alarm code	Number of times LED blinks	Alarm type	Cause	Remedial action	How to reset
10h	4	Excessive position deviation	<ul style="list-style-type: none"> When the motor was in a state of current ON, the deviation between the command position and actual position exceeded the value set in the "Following error window (6065h)" in the motor output shaft. A load is large. The acceleration/deceleration time is too short or the acceleration/deceleration rate is too fast relative to the load. The operating range of positioning push-motion operation was exceeded. 	<ul style="list-style-type: none"> Decrease the load. Increase the acceleration/deceleration time or slow the acceleration/deceleration rate. Increase the operating current. Reconsider the operation data. 	Any of reset operations
20h	5	Overcurrent	The motor, the cable, and the driver output circuit were short-circuited.	Turn off the main power supply and the control power supply first, and check the motor, the cable, and the driver are not damaged. After that, turn on the main power supply and the control power supply again. If the alarm is still not reset, the motor, the cable, or the driver may be damaged. Contact your nearest Oriental Motor sales office.	Turn on the control power supply again
21h	2	Main circuit overheat	The internal temperature of the driver reached the upper limit of the specification value.	Reconsider the ventilation condition.	Any of reset operations
22h	3	Overvoltage (AC power input driver)	<ul style="list-style-type: none"> The main power supply voltage exceeded the permissible value. A large load inertia was suddenly stopped. Vertical operation (elevating operation) was performed. 	<ul style="list-style-type: none"> Check the input voltage of the main power supply. Decrease the load. Increase the acceleration/deceleration time or slow the acceleration/deceleration rate. Connect our regeneration resistor RGB100. 	Turn on the control power supply again
22h	3	Overvoltage (DC power input driver)	<ul style="list-style-type: none"> The main power supply voltage exceeded the permissible value. A large load inertia was suddenly stopped. Vertical operation (elevating operation) was performed. 	<ul style="list-style-type: none"> Check the input voltage of the main power supply. Decrease the load. Increase the acceleration/deceleration time or slow the acceleration/deceleration rate. 	Any of reset operations
23h	3	Main power supply OFF	The main power supply was shut off during operation.	Check if the main power supply is applied properly.	Any of reset operations

Alarm code	Number of times LED blinks	Alarm type	Cause	Remedial action	How to reset
25h	3	Undervoltage	The main power supply was shut off momentarily or a voltage shortage was generated.	Check the input voltage of the main power supply.	Any of reset operations
26h	8	Motor overheat	The detection temperature of the ABZO sensor reached the upper limit of the specification value.	<ul style="list-style-type: none"> • Check the heat radiation condition of the motor. • Reconsider the ventilation condition. 	Any of reset operations
28h	8	Sensor error	An error of the ABZO sensor was detected during operation.	Turn off the main power supply and the control power supply, and check the connection of the motor. After that, turn on the main power supply and the control power supply again.	Turn on the control power supply again
2Ah	8	ABZO sensor communication error	An error was detected in communication between the driver and ABZO sensor.	Turn off the main power supply and the control power supply, and check the connection of the ABZO sensor. After that, turn on the main power supply and the control power supply again.	Turn on the control power supply again
30h	2	Overload	A load exceeding the maximum torque was applied for the time exceeding the value set in the "Overload alarm (4180h)."	<ul style="list-style-type: none"> • Decrease the load. • Increase the acceleration/ deceleration time or slow the acceleration/deceleration rate. • Increase the operating current. 	Any of reset operations
31h	2	Overspeed	The feedback speed of the motor output shaft exceeded the specification value.	<ul style="list-style-type: none"> • Reconsider the "Electronic gear (6091h-01h, 02h)" and set the speed of the motor output shaft to a value lower than the specification value. • If an overshoot is occurred at the time of accelerating, increase the acceleration time or slow the acceleration rate. 	Any of reset operations
33h	7	Absolute position error	The home information of the ABZO sensor was damaged.	Perform the position preset (P-PRESET) or return-to-home operation to set the home again.	Turn on the control power supply again
34h	2	Command pulse error	<ul style="list-style-type: none"> • The command pulse frequency exceeded the specification value. • The position preset (P-PRESET) of the driver was executed in the cyclic synchronous position mode when the motor was in an excitation state. 	<ul style="list-style-type: none"> • Decrease the frequency of the command pulse. • Put the motor into a non-excitation state before executing the position preset (P-PRESET) of the driver in the cyclic synchronous position mode. 	Any of reset operations
41h	9	EEPROM error	The data stored in the driver was damaged.	Initialize all parameters.	Turn on the control power supply again

Alarm code	Number of times LED blinks	Alarm type	Cause	Remedial action	How to reset
42h	8	Sensor error at power on	An error of the ABZO sensor was detected when the control power supply was turned on.	Turn off the main power supply and the control power supply, and check the connection of the ABZO sensor. After that, turn on the main power supply and the control power supply again.	Turn on the control power supply again
43h	8	Rotation error at power on	The motor was being rotated when the control power supply was turned on.	Reconsider the load conditions so that the motor output shaft does not rotate by an external force when the control power supply is turned on.	Turn on the control power supply again
44h	8	Encoder EEPROM error	The data stored in the ABZO sensor was damaged.	Execute either of the following operations. If the same alarm is still generated, the ABZO sensor has been damaged. Contact your nearest Oriental Motor sales office. <ul style="list-style-type: none"> • Set Z-phase again with the "ZSG-PRESET (40D1h)" of the maintenance command. • Execute the "Clear tripmeter (40CFh)" of the maintenance command. 	Turn on the control power supply again
45h	8	Motor combination error	A motor not allowed to combine with the driver was connected. Refer to p.224 for details.	Check the motor model and the driver model, and connect them in the correct combination.	Turn on the control power supply again
4Ah	7	Return-to-home incomplete	Absolute positioning operation was started in a state where the position coordinate had not been set.	<ul style="list-style-type: none"> • Reconsider the setting of the "Permission of absolute positioning without setting absolute coordinates (4148h)." • Execute the position preset (P-PRESET) or return-to-home operation. 	Any of reset operations
4Ch	7	Network initialization error	An error was detected during initialization of the EtherCAT module.	Turn on the control power supply again. If the alarm is still not reset, contact your nearest Oriental Motor sales office.	Turn on the control power supply again
51h	2	Regeneration resistor overheat (AC power input driver only)	<ul style="list-style-type: none"> • The regeneration resistor RGB100 is not connected properly. • The regeneration resistor RGB100 was overheated extraordinarily. 	<ul style="list-style-type: none"> • If the regeneration resistor RGB100 is not used, short the TH1 and TH2 terminals of the CN1. • Connect the regeneration resistor RGB100 properly. • The allowable regenerative power of the regeneration resistor RGB100 is exceeded. Reconsider the load and operating conditions. 	Turn on the control power supply again

Alarm code	Number of times LED blinks	Alarm type	Cause	Remedial action	How to reset
53h	2	HWTO input circuit error	<ul style="list-style-type: none"> The time after either the HWTO1 input or the HWTO2 input is turned OFF until the other input is turned OFF exceeded the value set in the "HWTO delay time of checking dual system (4191h)." An error of the circuit corresponding to the phenomenon above was detected. 	<ul style="list-style-type: none"> Increase the value set in the "HWTO delay time of checking dual system (4191h)" parameter. Check the wiring of the HWTO1 and HWTO2 inputs. 	Turn on the control power supply again
60h	7	±LS both sides active	<ul style="list-style-type: none"> When the "FW-LS/RV-LS input action (4701h)" is set to "2: Immediate stop with alarm" or "3: Deceleration stop with alarm," both the FW-LS input and the RV-LS input were detected. Return-to-home operation was executed in a state where both the FW-LS input and the RV-LS input were detected. 	Check the sensor logic installed and the "Inverting mode" parameter.	Any of reset operations
61h	7	Reverse ±LS connection	The LS input opposite to the operating direction was detected while return-to-home operation in 2-sensor mode or 3-sensor mode was performed.	Check the wiring of the sensor.	Any of reset operations
62h	7	Return-to-home operation error	<ul style="list-style-type: none"> An unanticipated load was applied while return-to-home operation was performed. The installation positions of the FW-LS and RV-LS sensors and the HOME sensor are near to each other. Position preset (P-PRESET) processing upon completion of return-to-home operation was failed. In return-to-home operation in one-way rotation mode, the motor passed by the HOME sensor during deceleration stop. 	<ul style="list-style-type: none"> Check the load. Reconsider the sensor installation positions and the starting direction of motor operation. See that a load exceeding the maximum torque is not applied upon completion of return-to-home operation. Reconsider the specification of the HOME sensor and the "Homing acceleration (609Ah)." 	Any of reset operations
63h	7	No HOMES	The HOMES input was not detected at a position between the FW-LS input and the RV-LS input while return-to-home operation in 3-sensor mode was performed.	Install the HOME sensor at a position between the FW-LS and RV-LS sensors.	Any of reset operations

Alarm code	Number of times LED blinks	Alarm type	Cause	Remedial action	How to reset
64h	7	TIM, ZSG, SLIT signal error	None of the TIM output, the ZSG output, or the SLIT input could be detected during return-to-home operation.	<ul style="list-style-type: none"> Reconsider the connection status of the load and the position of the HOME sensor so that these signals should be ON while the HOMES input is ON. When a signal is not used, set the "(HOME) TIM/ZSG signal detection (4167h)" or the "(HOME) SLIT detection (4166h)" to "0: Disable." 	Any of reset operations
66h	7	Hardware overtravel	When the "FW-LS/RV-LS input action (4701h)" is set to "2: Immediate stop with alarm" or "3: Deceleration stop with alarm," the FW-LS input or the RV-LS input was detected.	<ul style="list-style-type: none"> Reconsider the operation data. After resetting the alarm, operate the motor in the opposite direction to escape from the sensor. You can operate in any of operation modes. Reset the alarm and then escape from the sensor by manually. 	Any of reset operations
67h	7	Software overtravel	When the "Software overtravel (41C3h)" is set to "2: Immediate stop with alarm" or "3: Deceleration stop with alarm," the motor position reached the set value of the software limit.	<ul style="list-style-type: none"> Reconsider the operation data. After resetting the alarm, operate the motor in the opposite direction to escape from the sensor. You can operate in any of operation modes. Reset the alarm and then escape from the sensor by manually. 	Any of reset operations
68h	1	HWTO input detection	When the "HWTO mode selection (4190h)" is set to "1: Alarm is present," the HWTO1 input or the HWTO2 input was turned OFF.	Turn the HWTO1 input and the HWTO2 input ON.	Any of reset operations
6Ah	7	Return-to-home operation offset error	When offset movement as part of return-to-home operation is performed, the FW-LS input or the RV-LS input was detected.	Check the offset value.	Any of reset operations
6Dh	7	Mechanical overtravel	The product having set the home reached the mechanism limit stored in the ABZO sensor.	<ul style="list-style-type: none"> Check the travel amount (position). Reset the alarm and then escape from the sensor by operating the motor or manually. 	Any of reset operations

Alarm code	Number of times LED blinks	Alarm type	Cause	Remedial action	How to reset
70h	7	Operation data error	<ul style="list-style-type: none"> Operation was performed at the operating speed or operating current exceeding the value set in the "Mechanism protection parameter." Wrap operation was executed when "Wrap setting (41C7h)" was disabled. Push-motion operation or push-motion return-to-home operation was performed with the DGII Series. 	<ul style="list-style-type: none"> Check the operation data. Check the value set in the "Mechanism protection parameter" using the unit information monitor of the MEXE02. Check the setting of the wrap setting. Push-motion operation as well as push-motion return-to-home operation cannot be performed with the DGII Series. 	Any of reset operations
71h	7	Electronic gear setting error	The resolution set in the "Electronic gear (6091h-01h, 02h)" was out of the specification.	Reconsider the "Electronic gear (6091h-01h, 02h)," and set so that the resolution should be in the range of the specification.	Turn on the control power supply again
72h	7	Wrap setting error	The control power supply was turned on with the value set in the "Wrap setting (41C7h)" that is inconsistent with the resolution set in the "Electronic gear (6091h-01h, 02h)."	Set the wrap setting properly, and turn on the control power supply again.	Turn on the control power supply again
81h	7	Network bus error	<ul style="list-style-type: none"> A communication error of EtherCAT communication was detected during operation. The EtherCAT communication state machine (ESM) was moved to other than "Operational" during operation. 	Check the conditions of the connector, cable, and the MainDevice of EtherCAT communication.	Any of reset operations
82h	7	Network module error	An error was detected in the network module.	Turn on the control power supply again.	Turn on the control power supply again
F0h	Lit	CPU error	CPU malfunctioned.	Turn on the control power supply again.	Turn on the control power supply again

Related objects

Index	Sub	Name	Type	Access	PDO	Save	Initial value	Range	Update
4180h	00h	Overload alarm	INT16	RW	No	○	50	1 to 300 (1=0.1 s)	A
6065h	00h	Following error window	U32	RW	No	○	300	1 to 30,000 (1=0.01 rev)	A

■ About causes of the motor combination error (alarm code 45h)

An alarm of the motor combination error is generated in the following conditions.

- When the motor for a DC power supply was connected to the AC power input driver.
- When the motor for an AC power supply was connected to the DC power input driver.
- When the motor of frame size 20 mm (0.79 in.) or 28 mm (1.10 in.) was connected to the DC power input driver and 48 VDC was applied.

1-5 Timing chart

1. If an error occurs, the ALM-B output, the MOVE output, and the DCMD-RDY output (PLS-RDY output in pulse-input operation) are turned OFF.
At the same time, the motor stops and the motor excitation is cut off.
2. Remove the cause of the alarm and then turn the ALM-RST input ON.
The alarm is reset, and the ALM-B output is turned ON. If the excitation command is input from the MainDevice, the motor puts into an excitation state at the same time as the alarm is reset, and the READY output and the DCMD-RDY output (PLS-RDY output in pulse-input operation) are turned ON.



Check the following before resetting the alarm. The motor may suddenly start running, leading to injury or damage to equipment.

- When operating via EtherCAT communication
Execute the operation stop from the MainDevice. In the cyclic synchronous position mode (CSP), clear the position deviation between the MainDevice and the driver after the operation is stopped.
- In pulse-input operation
Stop the pulse input.

3. Check the ALM-B output has been turned ON and then turn the ALM-RST input OFF.

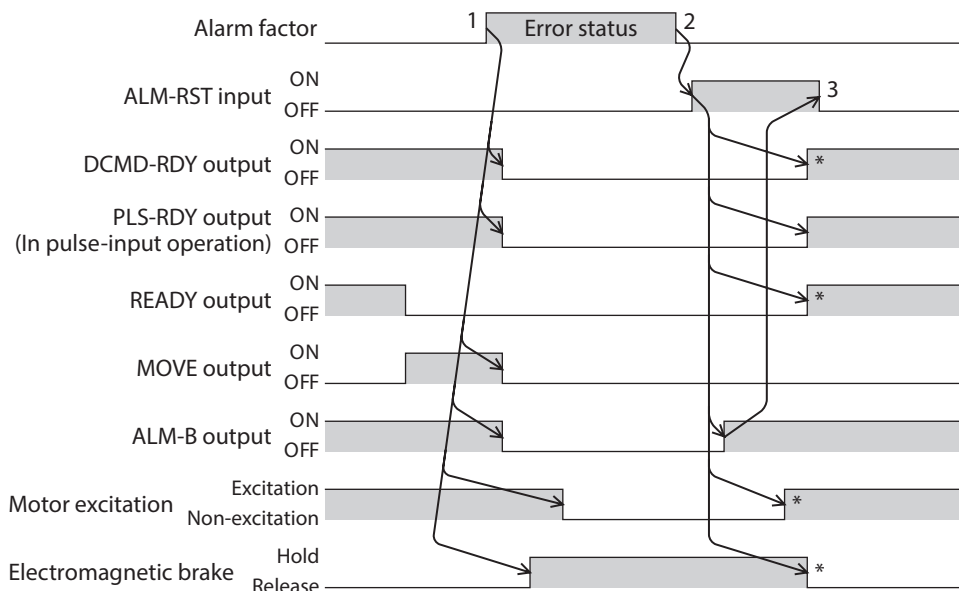

* It is the movement when the excitation command is input from the MainDevice while the ALM-RST input is turned ON.

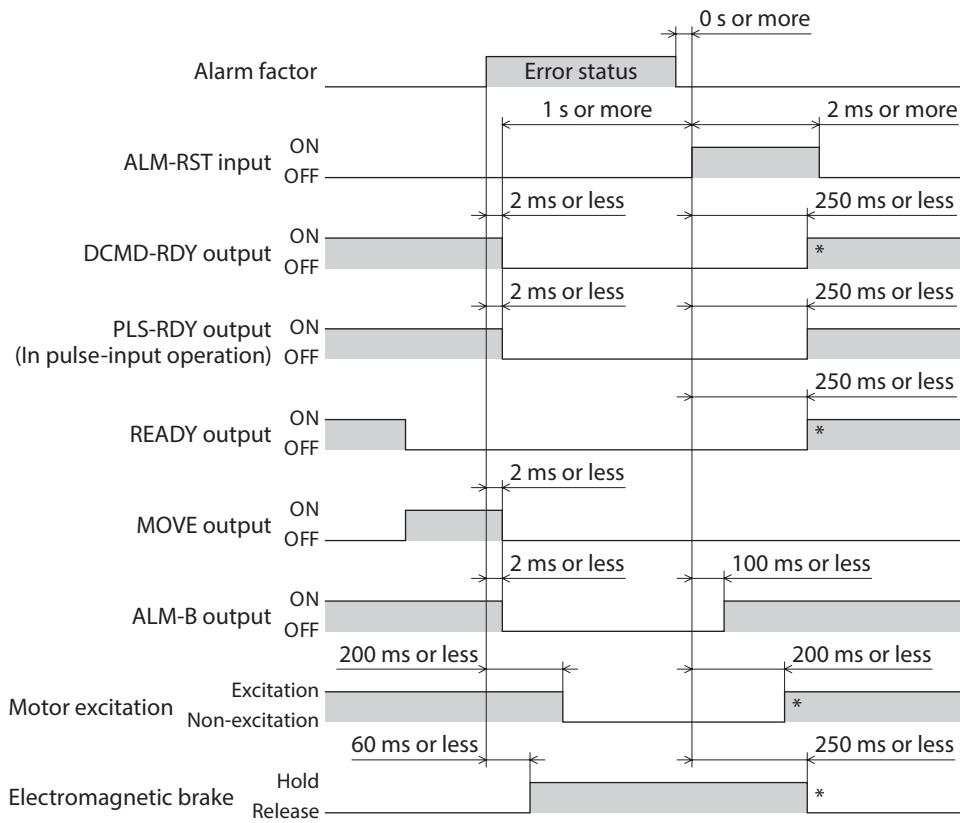

* It is the movement when the excitation command is input from the MainDevice while the ALM-RST input is turned ON.

2 Information

The driver is equipped with a function to generate information output before an alarm is generated. This function can be utilized for periodic maintenance of equipment by setting a suitable value in the parameter of each information.

For example, utilizing the “Motor temperature information (41A8h)” can prevent equipment malfunction or production stoppage due to motor overheat. In addition, the “Tripmeter information (41AFh)” can be utilized as a reference to do maintenances every time a certain travel distance is reached.

■ Status when information is generated

● Information bit output

If information is generated, a bit output (INFO-** output) of the corresponding information is turned ON.

A desired output signal can be assigned to the INFO-USRIO output among bit outputs and used. If the assigned output signal is turned ON, the INFO-USRIO output is also turned ON. For details about bit output, refer to p.229.

● INFO output

If information is generated, the INFO output is turned ON.

● LED indicator

If information is generated, the PWR/ALM LED will simultaneously blink in red and green twice. (Red and green colors may overlap and it may be visible to orange.)

● Motor operation

The motor continues to operate during information unlike in the case of an alarm.

● Parameter

Each information has a corresponding “INFO action” parameter. If the parameter is set to “0: No Info reflect,” only the bit output of information is turned ON, and the INFO output and LED are not changed.

Related objects

Index	Sub	Name	Type	Access	PDO	Save	Initial value	Range	Update
41A0h	00h	Driver temperature information (INFO-DRVTMP)	INT16	RW	RxPDO	○	40 to 85 °C	85	A
41A1h	00h	Overload time information (INFO-OLTIME)	INT16	RW	RxPDO	○	1 to 300 (1=0.1 s)	50	A
41A2h	00h	Speed information (INFO-SPD)	INT16	RW	RxPDO	○	0: Disable 1 to 12,000 r/min	0	A
41A5h	00h	Position deviation information (INFO-POSERR)	INT16	RW	RxPDO	○	1 to 30,000 (1=0.01 rev)	300	A
41A8h	00h	Motor temperature information (INFO-MTRTMP)	INT16	RW	RxPDO	○	40 to 120 °C	85	A
41A9h	00h	Overvoltage information (INFO-OVOLT) [AC power input driver]	INT16	RW	RxPDO	○	120 to 450 V	435	A
41AAh	00h	Undervoltage information (INFO-UVOLT) [AC power input driver]	INT16	RW	RxPDO	○	120 to 280 V	120	A
41ABh	00h	Overvoltage information (INFO-OVOLT) [DC power input driver]	INT16	RW	RxPDO	○	150 to 630 (1=0.1 V)	630	A
41ACh	00h	Undervoltage information (INFO-UVOLT) [DC power input driver]	INT16	RW	RxPDO	○	150 to 630 (1=0.1 V)	180	A
41AFh	00h	Tripmeter information (INFO-TRIP)	INT32	RW	RxPDO	○	0: Disable 1 to 2,147,483,647 (1=0.1 kRev)	0	A
41B0h	00h	Odometer information (INFO-ODO)	INT32	RW	RxPDO	○	0: Disable 1 to 2,147,483,647 (1=0.1 kRev)	0	A
41B1h	00h	Cumulative load 0 information (INFO-CULD0)	INT32	RW	RxPDO	○	0 to 2,147,483,647	0	A
41B2h	00h	Cumulative load 1 information (INFO-CULD1)	INT32	RW	RxPDO	○	0 to 2,147,483,647	0	A
41B3h	00h	Cumulative load value auto clear	U8	RW	No	○	0: Disable 1: Enable	1	A
41B4h	00h	Cumulative load value count divisor	U16	RW	No	○	1 to 32,767	1	A
41BCh	00h	INFO-USRIO output selection	U8	RW	No	○	Output signals list ⇨ p.160	128	A

Index	Sub	Name	Type	Access	PDO	Save	Initial value	Range	Update
41BDh	00h	INFO-USRIO output inversion	U8	RW	No	○	0: Not invert 1: Invert	0	A
41BEh	00h	Information LED condition	U8	RW	No	○	0: Disable (LED does not blink) 1: Enable (LED blinks)	1	A
41BFh	00h	Information auto clear	U8	RW	No	○	0: Disable (not turned OFF automatically) 1: Enable (turned OFF automatically)	1	A
47A0h	00h	INFO action (Assigned I/O status information (INFO-USRIO))	U8	RW	No	○	0: No Info reflect (Only the bit output is ON.) 1: Info reflect (The bit output and the INFO output are ON and the LED blinks.)	1	A
47A1h	00h	INFO action (Position deviation information (INFO-POSERR))	U8	RW	No	○			A
47A2h	00h	INFO action (Driver temperature information (INFO-DRVTMP))	U8	RW	No	○			A
47A3h	00h	INFO action (Motor temperature information (INFO-MTRTMP))	U8	RW	No	○			A
47A4h	00h	INFO action (Overvoltage information (INFO-OVOLT))	U8	RW	No	○			A
47A5h	00h	INFO action (Undervoltage information (INFO-UVOLT))	U8	RW	No	○			A
47A6h	00h	INFO action (Overload time information (INFO-OLTIME))	U8	RW	No	○			A
47A8h	00h	INFO action (Speed information (INFO-SPD))	U8	RW	No	○			A
47A9h	00h	INFO action (Start operation error information (INFO-START))	U8	RW	No	○			A
47AAh	00h	INFO action (Start ZHOME error information (INFO-ZHOME))	U8	RW	No	○			A
47ABh	00h	INFO action (PRESET request information (INFO-PR-REQ))	U8	RW	No	○			A
47ADh	00h	INFO action (Electronic gear setting error information (INFO-EGR-E))	U8	RW	No	○			A
47AEh	00h	INFO action (Wrap setting error information (INFO-RND-E))	U8	RW	No	○			A
47B0h	00h	INFO action (Forward operation prohibiton information (INFO-FW-OT))	U8	RW	No	○			A
47B1h	00h	INFO action (Reverse operation prohibiton information (INFO-RV-OT))	U8	RW	No	○			A
47B2h	00h	INFO action (Cumulative load 0 information (INFO-CULD0))	U8	RW	No	○			A
47B3h	00h	INFO action (Cumulative load 1 information (INFO-CULD1))	U8	RW	No	○			A
47B4h	00h	INFO action (Tripmeter information (INFO-TRIP))	U8	RW	No	○			A
47B5h	00h	INFO action (Odometer information (INFO-ODO))	U8	RW	No	○			A
47BCh	00h	INFO action (Start operation restricted mode information (INFO-DSLMTD))	U8	RW	No	○			A
47BDh	00h	INFO action (I/O test mode information (INFO-IOTEST))	U8	RW	No	○	A		
47BEh	00h	INFO action (Configuration request information (INFO-CFG))	U8	RW	No	○	A		
47BFh	00h	INFO action (Reboot request information (INFO-RBT))	U8	RW	No	○	A		

2-1 Information history

Up to 16 generated information items are saved in the RAM in order of the latest to oldest. Information items stored as the information history are the information code, generation time, and contents of information.

The information history can be read or cleared when one of the following items is performed.

- Read the information history by the "Information history (4510h to 451Fh)" via EtherCAT communication.
- Clear the history by setting the "Clear information history (40D4h)" of EtherCAT communication to 1. (The information will be clear when changing from 0 to 1.)
- Read and clear the information history using the **MEXE02**.



Information history is saved in the RAM, so they are cleared when the control power supply of the driver is turned OFF.

2-2 Information list

Information item	Information bit output signal	Cause	Reset condition
Assigned I/O status	INFO-USRIO	The I/O signal set in the "INFO-USRIO output selection (41BCh)" was turned ON.	The I/O signal set in the "INFO-USRIO output selection (41BCh)" was turned OFF.
Position deviation	INFO-POSERR	The deviation between the command position and the actual position exceeded the value set in the "Position deviation information (41A5h)" in the motor output shaft.	The deviation between the command position and the actual position fell below the value set in the "Position deviation information (41A5h)" in the motor output shaft.
Driver temperature	INFO-DRVTMP	The internal temperature of the driver exceeded the value set in the "Driver temperature information (41A0h)."	The internal temperature of the driver fell below the setting value of the "Driver temperature information (41A0h)."
Motor temperature	INFO-MTRTMP	The detection temperature of the encoder exceeded the value set in the "Motor temperature information (41A8h)."	The detection temperature of the encoder fell about 5 °C (9 °F) below the value set in the "Motor temperature information (41A8h)."
Overvoltage	INFO-OVOLT	<ul style="list-style-type: none"> • The voltage of the main power supply exceeded the value set in the "Overvoltage information (41A9h or 41ABh)." • A large load inertia was suddenly stopped. • Vertical operation (elevating operation) was performed. 	The voltage of the main power supply fell below the value set in the "Overvoltage information (41A9h or 41ABh)."
Undervoltage	INFO-UVOLT	<ul style="list-style-type: none"> • The voltage of the main power supply fell below the value set in the "Undervoltage information (41AAh or 41ACh)." • The main power supply was shut off momentarily or a voltage shortage was generated. 	The voltage of the main power supply exceeded the value set in the "Undervoltage information (41AAh or 41ACh)."
Overload time	INFO-OLTIME	A load exceeding the maximum torque was applied for a time period exceeding the value set in the "Overload time information (41A1h)."	The overload counter fell below the value set in the "Overload time information (41A1h)."
Speed	INFO-SPD	The feedback speed of the motor exceeded the value set in the "Speed information (41A2h)."	The feedback speed of the motor fell below the value set in the "Speed information (41A2h)."

Information item	Information bit output signal	Cause	Reset condition
Start operation error	INFO-START	<ul style="list-style-type: none"> • An operation in the direction being stopped by the FW-BLK input or the RV-BLK input was started. • An operation in the direction being stopped by the FW-LS input or the RV-LS input was started. • An operation in the direction being stopped by the software limit was started. • When operation could not be executed (e.g., the READY output was OFF), the operation start signal was turned ON. 	Operation was started normally.
Start ZHOME error	INFO-ZHOME	When the position coordinate was not set (the ABSPEN output was OFF), the high-speed return-to-home operation was started.	Operation was started normally.
Preset request	INFO-PR-REQ	Preset was executed by the position preset (P-PRESET) or return-to-home operation.	Preset was completed.
Electronic gear setting error	INFO-EGR-E	The resolution set in the "Electronic gear (6091h-01h, 02h)" was out of the specification.	The resolution was set in the range of the specification.
Wrap setting error	INFO-RND-E	The resolution and the "Initial coordinate generation & wrap setting range (41C9h)" were inconsistent.	The "Initial coordinate generation & wrap setting range (41C9h)" was set in the range of the specification.
Forward operation prohibition	INFO-FW-OT	<ul style="list-style-type: none"> • The positive software limit was exceeded. • Either the FW-LS input or the FW-BLK input was turned ON. 	The position coordinate of the motor was in the range of the positive software limit, and in addition, both the FW-LS input and the FW-BLK input were turned OFF.
Reverse operation prohibition	INFO-RV-OT	<ul style="list-style-type: none"> • The negative software limit was exceeded. • Either the RV-LS input or the RV-BLK input was turned ON. 	The position coordinate of the motor was in the range of the negative software limit, and in addition, both the RV-LS input and the RV-BLK input were turned OFF.
Cumulative load 0	INFO-CULD0	The cumulative load exceeded the value set in the "Cumulative load 0 information (41B1h)."	The cumulative load fell below the value set in the "Cumulative load 0 information (41B1h)."
Cumulative load 1	INFO-CULD1	The cumulative load exceeded the value set in the "Cumulative load 1 information (41B2h)."	The cumulative load fell below the value set in the "Cumulative load 1 information (41B2h)."
Tripmeter	INFO-TRIP	The travel distance of the motor exceeded the value set in the "Tripmeter information (41AFh)"	<p>After one of the following operation was performed, the travel distance (tripmeter) of the motor fell below the value set in the "Tripmeter information (41AFh)."</p> <ul style="list-style-type: none"> – The "Tripmeter information (41AFh)" was set again. – The "Clear tripmeter (40CFh)" of the maintenance command was executed.
Odometer	INFO-ODO	The cumulative travel distance of the motor exceeded the value set in the "Odometer information (41B0h)."	<p>After the following operation was performed, the cumulative travel distance (odometer) of the motor fell below the value set in the "Odometer information (41B0h)."</p> <ul style="list-style-type: none"> – The "Odometer information (41B0h)" was set again.

Information item	Information bit output signal	Cause	Reset condition
Start operation restricted mode	INFO-DSLMTD	<ul style="list-style-type: none"> • Configuration was executed. • "Remote operation" was executed using the MEXE02. • Data was written to the driver from the MEXE02. • "Restored to the factory setting" was executed with the MEXE02. 	<ul style="list-style-type: none"> • Configuration was complete. • Remote operation was canceled. • Writing data was complete. • Data was restored to the factory setting.
I/O test mode	INFO-IOTEST	<ul style="list-style-type: none"> • Configuration was executed. • "I/O test" was executed with the MEXE02. 	<ul style="list-style-type: none"> • Configuration was complete. • The I/O test mode was canceled.
Configuration request	INFO-CFG	Execution of configuration was requested.	Configuration was executed.
Reboot request	INFO-RBT	Reboot was requested.	Reboot was executed.



If the "Preset request" information was generated for 100 ms or more in a state where the "Information auto clear (41BFh)" was set to disable, the preset may have been failed. There are the following two possible reasons that the preset was failed.

- The ABZO sensor is not connected to the driver.
- The preset was executed in a state where the position deviation between the command position and the actual position was 1.8° or more.

■ Monitor of information

Information in details can be checked by the "Information (407Bh)."

The read information code is indicated in eight hexadecimal digits. It can also be read in 32 bits.

If multiple information items are generated, the logical sum (OR) of the information code is indicated.

Information code	32 bits indication	Information name	Output signal
00000001h	0000 0000 0000 0000 0000 0000 0000 0001	Assigned I/O status	INFO-USRIO
00000002h	0000 0000 0000 0000 0000 0000 0000 0010	Position deviation	INFO-POSERR
00000004h	0000 0000 0000 0000 0000 0000 0000 0100	Driver temperature	INFO-DRVTMP
00000008h	0000 0000 0000 0000 0000 0000 0000 1000	Motor temperature	INFO-MTRTMP
00000010h	0000 0000 0000 0000 0000 0000 0001 0000	Overvoltage	INFO-OVOLT
00000020h	0000 0000 0000 0000 0000 0000 0010 0000	Undervoltage	INFO-UVOLT
00000040h	0000 0000 0000 0000 0000 0000 0100 0000	Overload time	INFO-OLTIME
00000100h	0000 0000 0000 0000 0000 0001 0000 0000	Speed	INFO-SPD
00000200h	0000 0000 0000 0000 0000 0010 0000 0000	Start operation error	INFO-START
00000400h	0000 0000 0000 0000 0000 0100 0000 0000	Start ZHOME error	INFO-ZHOME
00000800h	0000 0000 0000 0000 0000 1000 0000 0000	Preset request	INFO-PR-REQ
00002000h	0000 0000 0000 0000 0010 0000 0000 0000	Electronic gear setting error	INFO-EGR-E
00004000h	0000 0000 0000 0000 0100 0000 0000 0000	Wrap setting error	INFO-RND-E
00010000h	0000 0000 0000 0001 0000 0000 0000 0000	Forward operation prohibition	INFO-FW-OT
00020000h	0000 0000 0000 0010 0000 0000 0000 0000	Reverse operation prohibition	INFO-RV-OT
00040000h	0000 0000 0000 0100 0000 0000 0000 0000	Cumulative load 0	INFO-CULD0
00080000h	0000 0000 0000 1000 0000 0000 0000 0000	Cumulative load 1	INFO-CULD1
00100000h	0000 0000 0001 0000 0000 0000 0000 0000	Tripmeter	INFO-TRIP
00200000h	0000 0000 0010 0000 0000 0000 0000 0000	Odometer	INFO-ODO
10000000h	0001 0000 0000 0000 0000 0000 0000 0000	Start operation restricted mode	INFO-DSLMTD
20000000h	0010 0000 0000 0000 0000 0000 0000 0000	I/O test mode	INFO-IOTEST
40000000h	0100 0000 0000 0000 0000 0000 0000 0000	Configuration request	INFO-CFG
80000000h	1000 0000 0000 0000 0000 0000 0000 0000	Reboot request	INFO-RBT

3 Troubleshooting and remedial actions

In motor operation, the motor or driver may not function properly due to an improper setting or wrong connection. When the motor cannot be operated properly, refer to the contents provided in this chapter and take an appropriate remedial action.
If the problem persists, contact your nearest Oriental Motor sales office.

This chapter describes problems that may occur in operation other than the initial settings. Refer to the AZ Series OPERATING MANUAL Function Edition for these contents.

Phenomenon	Possible cause	Remedial action
<ul style="list-style-type: none"> The motor is not excited. The motor output shaft can be moved by hand. 	Connection error of the motor cable.	Check the motor connection.
	The FREE input is being ON.	Turn the FREE input OFF.
The motor has a holding torque even if it is put into a non-excitation state.	Effect of dynamic brake.	If the motor is put into a non-excitation state, the motor windings is brought into a state of being short-circuited inside the driver, generating a larger holding torque than when no current is supplied (dynamic brake). To release the dynamic brake, shut off the control power supply or turn the FREE input ON. With the "Non-excitation mode selection (413Dh)," you can select whether to enable the dynamic brake status or the free-run status when the motor is in a non-excitation state.
The motor does not operate.	When an electromagnetic brake motor is used, the electromagnetic brake is in a holding state.	Check the connection of the electromagnetic brake.
	The STOP input is being ON.	Turn the STOP input OFF.
The motor rotates in the direction opposite to the specified direction.	The "Motor rotation direction (41C2h)" is set wrongly.	Check the setting of the "Motor rotation direction (41C2h)."
The gearhead output shaft rotates in the direction opposite to the motor.	The geared motor that rotates in the direction opposite to the motor output shaft is used.	<ul style="list-style-type: none"> With TS geared type, the gear output shaft rotates in the direction opposite to the motor when the gear ratio is 20 or 30. With Harmonic geared type, the gear output shaft always rotates in the direction opposite to the motor.
Motor operation is unstable.	Connection error in the motor cable or the power supply cable.	Check the connections between the driver, the motor and the main power supply.
	The value set in the "Base current (4126h)" is too low.	Check the setting of the "Base current (4126h)." If the motor current value is low with respect to a load, the torque will also be low and the operation will be unstable.
Motor vibration is too large.	The load is small.	Lower the current with the "Base current (4126h)." If the motor output torque is too large relative to the load, vibration will increase.
The electromagnetic brake is not in a state of releasing.	The power is not supplied to the electromagnetic brake.	Check the connection of the electromagnetic brake.



When an alarm generates, check the alarm message using the EtherCAT communication or **MEXE02**.

7 Test operation using pulses

◆ Table of contents

1	To execute operation by inputting pulses.....	236
1-1	Operation flow.....	236



1 To execute operation by inputting pulses

This part explains the flow to execute pulse-input operation.
 Pulse-input operation can be used for test operation to check the motor movement.
 The dedicated excitation signal (CON) is used to excite the motor.

1-1 Operation flow

1. Turn on the main power supply and the control power supply.
2. Check the excitation command of EtherCAT communication is in an OFF state (the state is other than "Operation enabled").
3. Turn the CON input ON.
4. Check the PLS-RDY output has been turned ON and input pulses.

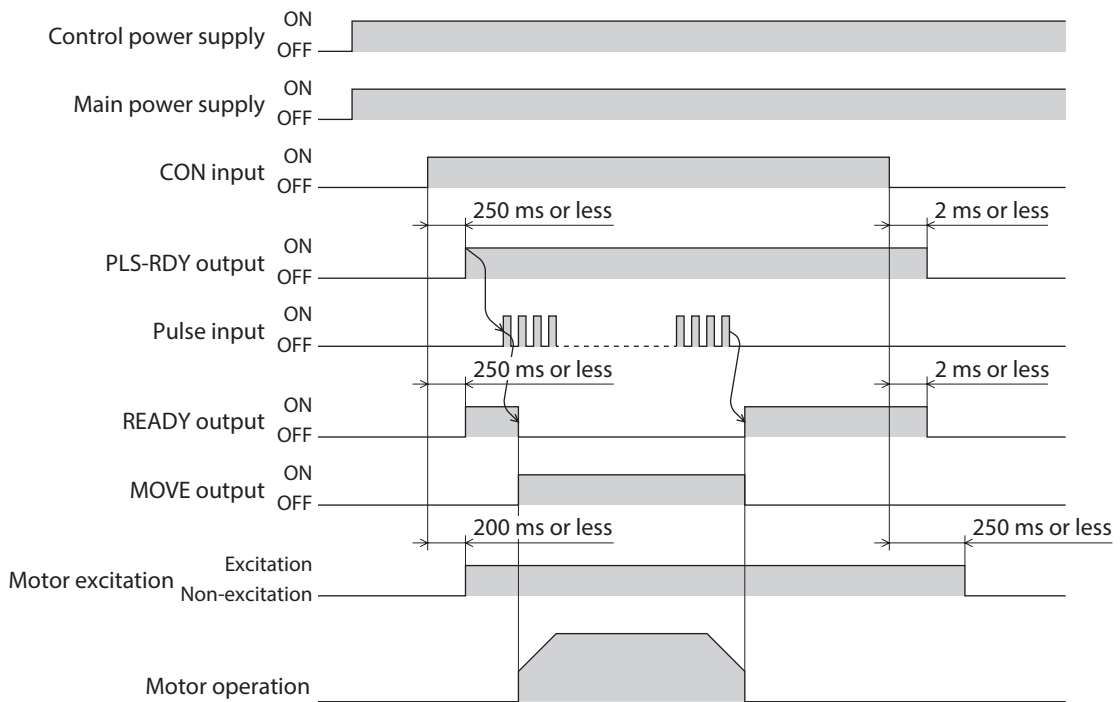

- The test operation cannot be started because the PLS-RDY is not turned ON even if the CON input is turned ON while the motor is in an excitation state via EtherCAT communication.
- The motor excitation state cannot be controlled or the motor operation cannot be executed via EtherCAT communication while pulse-input operation is performed.

8 Reference materials

◆ Table of contents

1	Timing chart	238
2	Specifications	239
	2-1 General specifications.....	239
	2-2 Product specifications.....	240
3	Regulations and standards.....	242
	3-1 UL Standards, CSA Standards.....	242
	3-2 CE Marking / UKCA Marking (AC power input driver).....	242
	3-3 CE Marking / UKCA Marking (DC power input driver).....	244
	3-4 Functional safety.....	244



1 Timing chart

■ Power ON

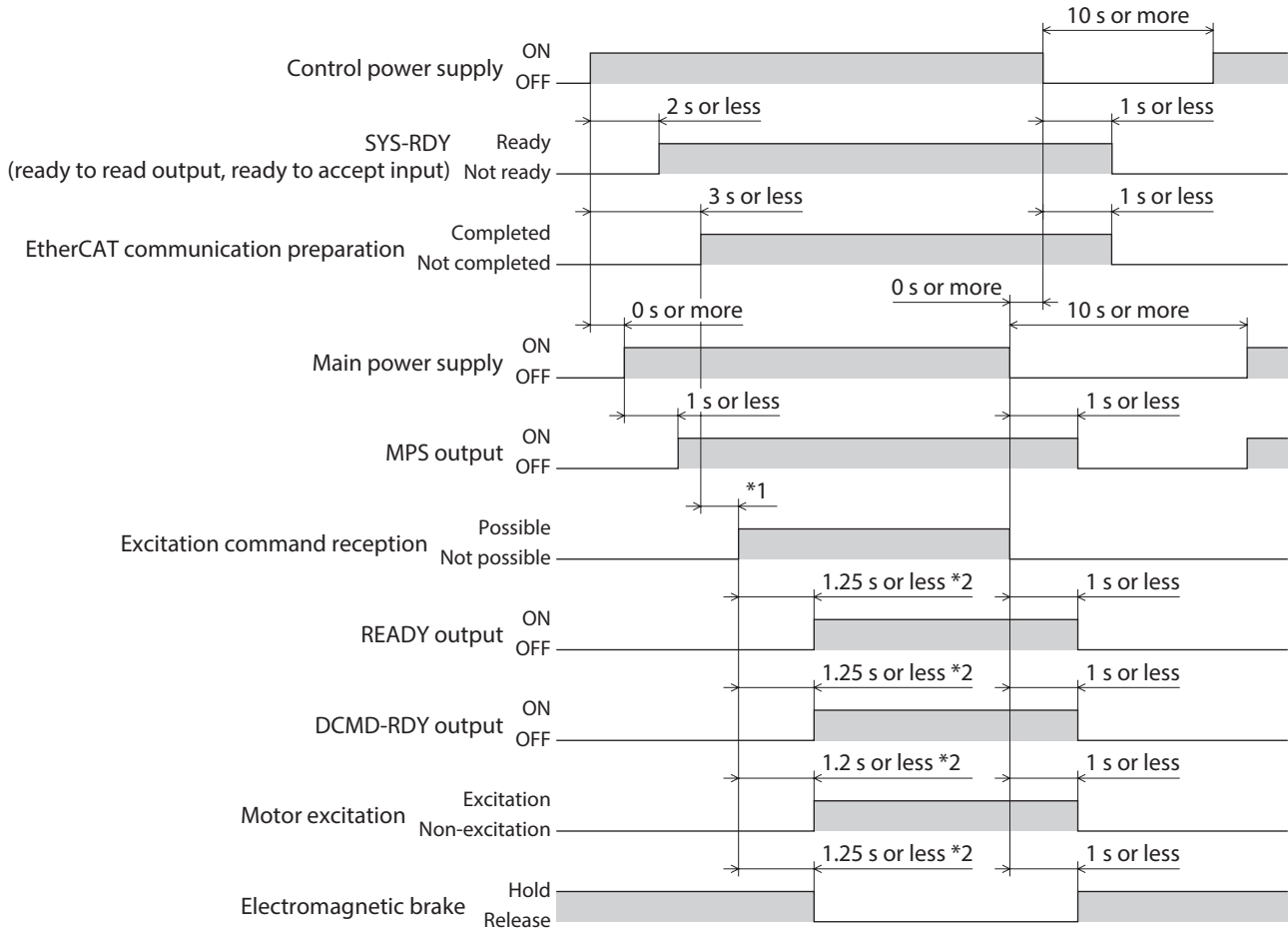

*1 It varies depending on the timing when the command is transited from the MainDevice.

*2 It represents when the excitation command is received at the same time as the excitation command reception is changed to "Possible."

2 Specifications

2-1 General specifications

■ AC power input driver

Degree of protection		IP10
Operating environment	Ambient temperature	0 to +55 °C (+32 to +131 °F) * (non-freezing)
	Humidity	85 % or less (non-condensing)
	Altitude	Up to 1,000 m (3,300 ft.) above sea level
	Surrounding atmosphere	No corrosive gas, dust, water, or oil.
Storage environment	Ambient temperature	-25 to +70 °C [-13 to +158 °F] (non-freezing)
	Humidity	85 % or less (non-condensing)
Shipping environment	Altitude	Up to 3,000 m (10,000 ft.) above sea level
	Surrounding atmosphere	No corrosive gas, dust, water, or oil.
Insulation resistance		100 MΩ or more when 500 VDC megger is applied between the following places: · Protective Earth Terminal - Main power supply input terminal · Encoder connector - Main power supply input terminal · I/O signal connector - Main power supply input terminal
Dielectric strength		Sufficient to withstand the specified voltage applied between the following places for 1 minute: · Protective Earth Terminal - Main power supply input terminal 1.5 kVAC 50/60 Hz · Encoder connector - Main power supply input terminal 1.8 kVAC 50/60 Hz · I/O signal connector - Main power supply input terminal 1.8 kVAC 50/60 Hz

* When installing a driver on a heat sink [material: aluminum, 200×200×2 mm (7.87×7.87×0.08 in.) or equivalent].

■ DC power input driver

Degree of protection		IP20
Operating environment	Ambient temperature	0 to +50 °C (+32 to +122 °F) (non-freezing)
	Humidity	85 % or less (non-condensing)
	Altitude	Up to 1,000 m (3,300 ft.) above sea level
	Surrounding atmosphere	No corrosive gas, dust, water, or oil.
Storage environment	Ambient temperature	-25 to +70 °C (-13 to +158 °F) (non-freezing)
	Humidity	85 % or less (non-condensing)
Shipping environment	Altitude	Up to 3,000 m (10,000 ft.) above sea level
	Surrounding atmosphere	No corrosive gas, dust, water, or oil.
Insulation resistance		100 MΩ or more when 500 VDC megger is applied between the following places: · Frame Ground Terminal - Power supply input terminal *

* The main power supply input terminals and the control power supply input terminals are not electrically insulated. Check using either of terminals.

2-2 Product specifications

■ AC power input driver

Driver model		AZD-AED	AZD-CED
Main power supply	Input voltage	Single-phase 100-120 VAC -15 to +6 % 50/60 Hz	<ul style="list-style-type: none"> • Single-phase 200-240 VAC -15 to +6 % 50/60 Hz • Three-phase 200-240 VAC -15 to +6 % 50/60 Hz
	Input current	2.7 to 6.4 A *1	Single-phase: 1.6 to 3.9 A *1 Three-phase: 1.0 to 2.3 A *1
Control power supply	Input voltage	24 VDC±5 % *2	
	Input current	0.25 A (0.5 A) *3	
Interface	Pulse input	<ul style="list-style-type: none"> • 3 to 5.25 VDC Number of input points: 2, photocoupler • Maximum input pulse frequency <ul style="list-style-type: none"> · Line driver output of the host controller 1 MHz (duty cycle 50 %) · Open-collector output of the host controller 250 kHz (duty cycle 50 %) 	
	Control input	Number of input points: 6, photocoupler	
	Pulse output	Number of output points: 2, line driver	
	Control output	Number of output points: 6, photocoupler/open collector	
	Power removal signal input	Number of input points: 2, photocoupler	
	Power removal monitor output	Number of output point: 1, photocoupler/open collector	
Field network	EtherCAT		

*1 The input current varies depending on the motor combined. Check on p.28.

*2 When an electromagnetic brake motor is used, the input voltage is 24 VDC±4 % if the wiring distance between the cable type motor and the driver is extended to 20 m (65.6 ft.) using our cable.

*3 The value in parentheses () is the one when the electromagnetic brake motor is connected. The **AZM46** type is 0.33 A.

■ DC power input driver

Driver model		AZD-KED2
Main power supply	Input voltage	<ul style="list-style-type: none"> ● 24 VDC±5 % ● 48 VDC±5 %
	Input current	0.4 to 3.3 A *1
Control power supply	Input voltage	24 VDC±5 % *2
	Input current	0.15 A (0.4 A) *3
Interface	Pulse input	<ul style="list-style-type: none"> ● 3 to 5.25 VDC Number of input points: 2, photocoupler ● Maximum input pulse frequency <ul style="list-style-type: none"> · Line driver output of the host controller 1 MHz (duty cycle 50 %) · Open-collector output of the host controller 250 kHz (duty cycle 50 %)
	Control input	Number of input points: 6, photocoupler
	Pulse output	Number of output points: 2, line driver
	Control output	Number of output points: 6, photocoupler/open collector
	Power removal signal input	Number of input points: 2, photocoupler
	Power removal monitor output	Number of output point: 1, photocoupler/open collector
Field network	EtherCAT	

*1 The input current varies depending on the motor combined. Check on p.68.

*2 When an electromagnetic brake motor is used, the input voltage is 24 VDC±4 % if the wiring distance between the cable type motor and the driver is extended to 20 m (65.6 ft.) using our cable.

*3 The value in parentheses () is the one when the electromagnetic brake motor is connected. The **AZM46** type is 0.23 A.

3 Regulations and standards

3-1 UL Standards, CSA Standards

This product is recognized by UL under UL and CSA Standards.

The driver is not provided with the electronic motor overload protection and the motor overtemperature protection specified in UL and CSA Standards.

3-2 CE Marking / UKCA Marking (AC power input driver)

This product is affixed with the marks under the following directives/regulations.

EU Declaration of Conformity can be downloaded from Download Page of the product in Oriental Motor Website (<https://www.orientalmotor.eu/eu>).

■ EU Low Voltage Directive / UK Electrical Equipment (Safety) Regulation

● Installation conditions

Overvoltage category	II
Pollution degree	2
Degree of protection	IP10
Protection against electric shock	Class I Equipment

- This product cannot be used in IT power distribution systems.
- Isolate the motor cable, the power supply cable and other drive cables from the signal cables by means of double insulation.
- The temperature of the driver's heat sink may exceed 90 °C (194 °F) depending on the driving condition. Observe the followings.
 - Be sure to perform test operation and check the driver temperature.
 - Do not use the driver near combustibles.
 - Do not touch the driver while operating.
- Use a circuit breaker conforming to EN or IEC Standards.
- The driver is not provided with the electronic motor overload protection and the motor overtemperature protection specified in EN Standards.
- The driver is not provided with the ground fault protection circuit. Wire the product in accordance with "Example of wiring to power supply considering ground fault protection" on p.243. Also observe the followings.
 - Earth leakage breaker: Rated current 15 A, rated sensitivity current 30 mA
 - When connecting to a power supply of Overvoltage category III, use an insulation transformer to ground its secondary side (N for single-phase, neutral point for three-phase).
 - Fault loop impedance: Equal to or less than the value in table

Power supply specifications of driver	Fault loop impedance
Single-phase 100-120 VAC	500 Ω
Single-phase 200-240 VAC Three-phase 200-240 VAC (Delta connection)	1,000 Ω
Three-phase 200-240 VAC (Star connection)	577 Ω

● Example of wiring to power supply considering ground fault protection

Single-phase 100-120 VAC, Single-phase 200-240 VAC

- TN power distribution systems

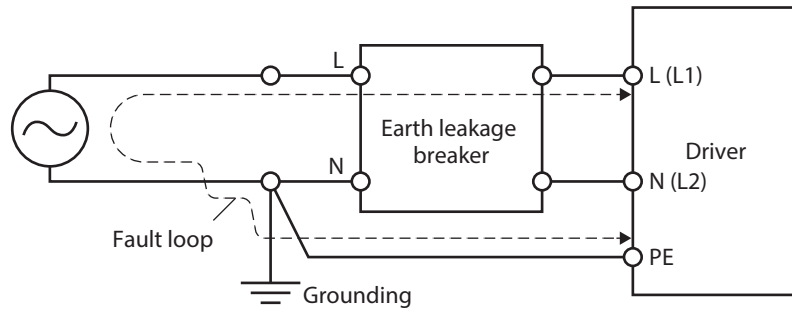

- TT power distribution systems

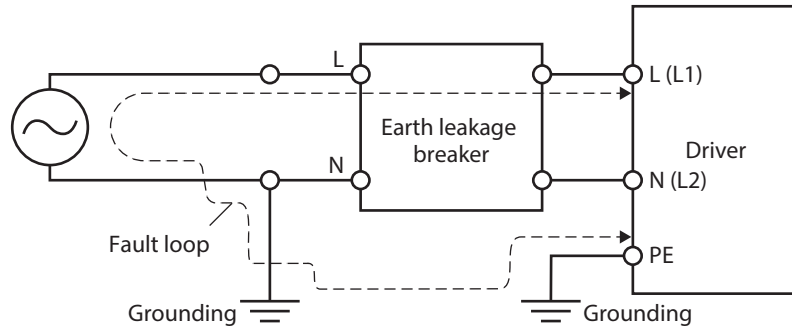

Three-phase 200-240 VAC

- TN power distribution systems

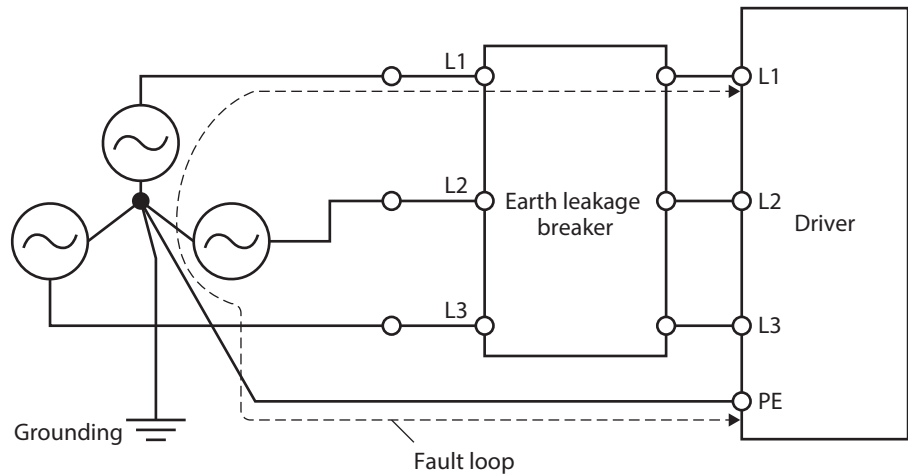

- TT power distribution systems

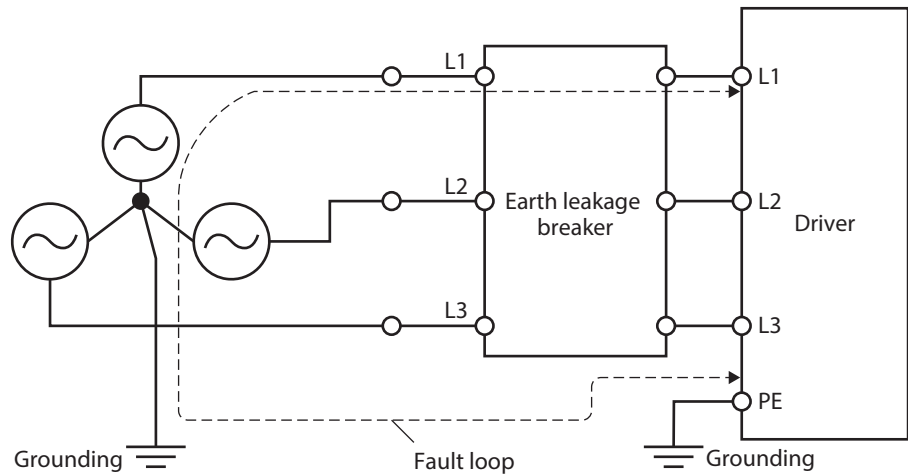

■ **EU Machinery Directive / UK Machinery Regulation**

Applicable standards: EN ISO 12100, EN 61800-5-2, EN ISO 13849-1: 2015

■ **EU EMC Directive / UK EMC Regulation**

Refer to "4-10 Conformity to the EMC Directive/Regulations" on p.37 for details about conformity.

■ **EU RoHS Directive / UK RoHS Regulation**

This product does not contain the substances exceeding the restriction values.

3-3 CE Marking / UKCA Marking (DC power input driver)

This product is affixed with the marks under the following directives/regulations.

EU Declaration of Conformity can be downloaded from Download Page of the product in Oriental Motor Website (<https://www.orientalmotor.eu/eu>).

■ **EU Machinery Directive / UK Machinery Regulation**

Applicable standards: EN ISO 12100, EN 61800-5-2, EN ISO 13849-1: 2023

■ **EU EMC Directive / UK EMC Regulation**

Refer to "4-8 Conformity to the EMC Directive/Regulations" on p.76 for details about conformity.

■ **EU RoHS Directive / UK RoHS Regulation**

This product does not contain the substances exceeding the restriction values.

3-4 Functional safety

This product is certified by TÜV SÜD Product Service GmbH under the following standards and affixed with the TÜV SÜD Mark. It is not a certified product if the TÜV SÜD Mark is not affixed.

■ **AC power input driver**

Applicable standards	Functional safety	IEC 61800-5-2, EN 61800-5-2 IEC 61508-1, EN 61508-1 IEC 61508-2, EN 61508-2 ISO 13849-1: 2015, EN ISO 13849-1: 2015
	Electrical safety	IEC 61800-5-1, EN 61800-5-1
	EMC	IEC 61000-6-7, EN 61000-6-7
	Safety function	STO (Safe Torque Off)

■ **DC power input driver**

Applicable standards	Functional safety	IEC 61800-5-2, EN 61800-5-2 IEC 61508-1, EN 61508-1 IEC 61508-2, EN 61508-2 ISO 13849-1: 2023, EN ISO 13849-1: 2023
	Electrical safety	EN 61800-5-1
	EMC	IEC 61000-6-7, EN 61000-6-7
	Safety function	STO (Safe Torque Off)

- Overvoltage category: I
- Pollution degree: 2
- Vibration resistance: 10 to 57 Hz, amplitude 0.0075 mm
57 to 150 Hz, acceleration 9.8 m/s² (1 G)
- Impact resistance: 50 m/s² (5 G), 30 ms
- The driver does not provide the electronic motor overload protection and motor overtemperature protection that are specified in the EN Standards.

- Install the driver in an enclosure whose degree of protection is IP54 minimum.
- Use a power supply that is certified as compatible with SELV for the control power supply.

- Unauthorized reproduction or copying of all or part of this manual is prohibited.
If a new copy is required to replace an original manual that has been damaged or lost, please contact your nearest Oriental Motor sales office.
- Oriental Motor shall not be liable whatsoever for any problems relating to industrial property rights arising from use of any information, circuit, equipment or device provided or referenced in this manual.
- Characteristics, specifications and dimensions are subject to change without notice.
- While we make every effort to offer accurate information in the manual, we welcome your input. Should you find unclear descriptions, errors or omissions, please contact your nearest Oriental Motor sales office.
- **Orientalmotor**, ***αSTEP***, and ABZO sensor are registered trademarks or trademarks of Oriental Motor Co., Ltd., in Japan and other countries.
EtherCAT® is a registered trademark and patented technology, licensed by Beckhoff Automation GmbH, Germany.
Other product names and company names mentioned in this manual may be registered trademarks or trademarks of their respective companies and are hereby acknowledged. The third-party products mentioned in this manual are recommended products, and references to their names shall not be construed as any form of performance guarantee. Oriental Motor is not liable whatsoever for the performance of these third-party products.

© Copyright ORIENTAL MOTOR CO., LTD. 2025

Published in August 2025

- Please contact your nearest Oriental Motor office for further information.

ORIENTAL MOTOR U.S.A. CORP.
Technical Support Tel:800-468-3982
8:30am EST to 5:00pm PST (M-F)

ORIENTAL MOTOR (EUROPA) GmbH
Schiesstraße 44, 40549 Düsseldorf, Germany
Technical Support Tel:00 800/22 55 66 22

ORIENTAL MOTOR (UK) LTD.
Blythe Valley Business Park,
Central Blvd Blythe Valley Park,
Solihull B90 8AG, United Kingdom
Tel:+44-1926-671220

ORIENTAL MOTOR (FRANCE) SARL
Tel:+33-1 47 86 97 50

ORIENTAL MOTOR ITALIA s.r.l.
Tel:+39-02-93906347

ORIENTAL MOTOR ASIA PACIFIC PTE. LTD.
Singapore
Tel:1800-842-0280

ORIENTAL MOTOR (MALAYSIA) SDN. BHD.
Tel:1800-806-161

ORIENTAL MOTOR (THAILAND) CO., LTD.
Tel:1800-888-881

ORIENTAL MOTOR (INDIA) PVT. LTD.
Tel:1800-120-1995 (For English)
1800-121-4149 (For Hindi)

TAIWAN ORIENTAL MOTOR CO., LTD.
Tel:0800-060708

SHANGHAI ORIENTAL MOTOR CO., LTD.
Tel:400-820-6516

INA ORIENTAL MOTOR CO., LTD.
Korea
Tel:080-777-2042

ORIENTAL MOTOR CO., LTD.
4-8-1 Higashiueno, Taito-ku, Tokyo
110-8536 Japan
Tel:+81-3-6744-0361
www.orientalmotor.co.jp/ja