

2-Phase/5-Phase Stepping Motors

PKP Series

OPERATING MANUAL

Table of contents

1	Introduction	2	6	Connection	18
2	Safety precautions	3	7	Inspection and maintenance.....	31
3	Precautions for use.....	5	8	Specifications	32
4	Preparation	8	9	Regulations and standards...	33
5	Installation.....	14			

Thank you for purchasing an Oriental Motor product.

This operating manual describes product handling procedures and safety precautions.

- Please read the manual thoroughly to ensure safe operation.
- Always keep the manual where it is readily available.

1 Introduction

■ Before using the product

Only qualified personnel of electrical and mechanical engineering should work with the product.





Use the product properly after thoroughly reading the section "2 Safety precautions" on p.3. In addition, be sure to observe the contents described in warning, caution, and note in this manual.

The product described in this manual is designed and manufactured to be incorporated into general industrial equipment. Do not use it for any other purpose. Oriental Motor Co., Ltd. is not responsible for any compensation for damage caused through failure to observe this warning.



2 Safety precautions



The precautions described below are intended to ensure the safe and proper use of the product and to prevent the user and other personnel from exposure to the risk of injury. Use the product only after carefully reading and fully understanding these instructions.





Description of signs

 WARNING	Handling the product without observing the instructions that accompany a "WARNING" symbol may result in serious injury or death.
 CAUTION	Handling the product without observing the instructions that accompany a "CAUTION" symbol may result in injury or property damage.
	The items under this heading contain important handling instructions that the user should observe to ensure safe use of the product.
	The items under this heading contain related information and contents to gain a further understanding of the text in this manual.

Description of graphic symbols

	Indicates "prohibited" actions that must not be performed.
	Indicates "compulsory" actions that must be performed.

 WARNING	
	<ul style="list-style-type: none"> Do not use the product in explosive or corrosive environments, in the presence of flammable gases, in areas subjected to splashing water, or near combustible materials. Doing so may result in fire or injury. The brake mechanism of the electromagnetic brake motor is designed for the purpose of holding the moving part and motor positions. Do not use it to brake motor rotation or as a safety brake. Doing so may result in injury or damage to equipment. Do not use force to bend, pull, or pinch the lead wire or cable. Doing so may result in fire. Do not disassemble or modify the product. Doing so may result in injury.
	<ul style="list-style-type: none"> Assign qualified personnel to the task of installing, wiring, operating, inspecting, and troubleshooting the product. Handling by unqualified personnel may result in fire or injury. When using the product in a vertical drive application such as elevating equipment, be sure to take measures to hold the moving part in position. Failure to do so may result in injury or damage to equipment. Install the product in an enclosure. Failure to do so may result in injury. Connect the product securely according to the connection diagram. Failure to do so may result in fire. Use a DC power supply with reinforced insulation on its primary and secondary sides for a power supply. Failure to do so may result in electric shock.

 CAUTION	
	<ul style="list-style-type: none"> • Do not use the product beyond the specifications. Doing so may result in injury or damage to equipment. • Keep fingers and objects out of the openings in the product. Failure to do so may result in fire or injury. • Do not touch the product during operation or immediately after stopping. The surface is hot, and this may cause a skin burn(s). • Do not lift the motor by holding the output shaft, lead wire or cable. Doing so may result in injury. • Keep the area around the product free of combustible materials. Failure to do so may result in fire or a skin burn(s). • Do not leave anything around the product that would obstruct ventilation. Doing so may result in damage to equipment. • Do not touch the rotating part (output shaft) while operating the motor. Doing so may result in injury.
	<ul style="list-style-type: none"> • Provide a cover over the rotating part (output shaft) of the motor. Failure to do so may result in injury. • Use a motor and driver only in the specified combination. An incorrect combination may cause a fire. • Provide an emergency stop device or emergency stop circuit external to the equipment so that the entire system will operate safely in the event of a system failure or malfunction. Failure to do so may result in injury. • If any abnormality is observed, stop operation immediately to disconnect power to the driver. Failure to do so may result in fire or injury. • The motor surface temperature may exceed 70 °C (158 °F) even under normal operating conditions. If the operator is allowed to approach the motor during operation, affix a warning label on a conspicuous place as shown in the figure. The surface is hot, and this may cause a skin burn(s). <div style="text-align: right; margin-top: 10px;">  Warning label </div>

3 Precautions for use

- **When conducting the insulation resistance measurement or the dielectric strength test, be sure to separate the connection between the motor and the driver.**

Conducting the insulation resistance measurement or the dielectric strength test with the motor and driver connected may result in damage to the product.

- **Use the motor in a condition where a radial load and an axial load are equal to or less than the permissible values.**

Continuing to operate the motor with a radial load or axial load exceeding the permissible value may cause damage to the bearings (ball bearings). Be sure to operate the motor within the permissible radial load and axial load.

- **Motor surface temperature**

The surface temperature of the motor case may exceed 100 °C (212 °F) depending on operating conditions such as ambient temperature, operating speed, operating duty, and others. To prevent the bearings (ball bearings) from reaching the end of their useful life prematurely, use the motor in a condition where the surface temperature of the motor case does not exceed 100 °C (212 °F). Use a geared type product under conditions where the case temperature of the gearhead does not exceed 70 °C (158 °F) to prevent deterioration of the grease and parts in the gearhead. To protect the encoder, use the motor with encoder in a condition where the surface temperature of the motor case does not exceed 85 °C (185 °F)*.

* 100 °C (212 °F) or less for the 13 mm (0.51 in.) frame size motor with encoder.

- **Holding torque at motor standstill**

The holding torque of the motor is reduced by the current cutback function of the driver while the motor is stopped. When selecting a motor, consider the torque reduction while the motor is stopped.

- **Rotation direction of the motor output shaft**

If the motor is excited in the order shown in the table, it rotates in the clockwise (CW) direction when viewed from the motor output shaft side.

● Bipolar

Excitation sequence	Black	Green	Red	Blue
1	-	+	+	-
2	-	+	-	+
3	+	-	-	+
4	+	-	+	-

● Unipolar

Excitation sequence	A	\bar{A}	B	\bar{B}
1	ON		ON	
2		ON	ON	
3		ON		ON
4	ON			ON

● Standard type motor

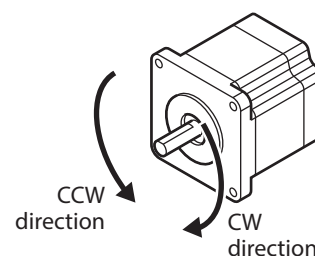

■ Electromagnetic brake motors

- **Do not use the electromagnetic brake to brake motor rotation or as a safety brake.**

Do not use the electromagnetic brake as a means to brake and stop the motor. The brake hub of the electromagnetic brake will wear significantly and the braking force will drop. Since the power-off activated type electromagnetic brake is equipped, it helps to maintain the position of the load when the power is cut off, but this brake is not a mechanism that will hold the load securely. Accordingly, do not use the electromagnetic brake as a safety brake. To use the electromagnetic brake to hold the load in position, do so after the motor has stopped.

■ Motors with encoder

- **Take measures against static electricity to the encoder.**

The encoder uses semiconductor components. Since static electricity may damage semiconductor components, be extremely careful when handling it.

- **Do not apply a strong impact to the output shaft or encoder.**

Doing so may result in damage to the encoder.

- **Do not connect or disconnect the connector while the power is on.**

Doing so may result in damage to the encoder.

- **Keep the encoder away from a strong magnetic field.**

When **R3** is included in the model name, which indicates the encoder resolution, a magnetic sensor is built into the encoder. Installing the motor near equipment that generates a strong magnetic field may affect the angular accuracy of the encoder. Pay attention to the environment for transport and storage or the installation location for use.

- **Geared type products**

- **Grease leakage measures**

In rare cases, a small amount of grease may ooze out from the gearhead. If there is concern about potential environmental damage from grease leakage, check for grease stains during periodic inspections. Alternatively, install an oil pan or other device to prevent damage resulting from contamination. Oil leakage may cause problems in the customer's equipment or products.

- **Permissible torque**

When operating the motor at a constant speed, do not exceed the permissible torque specified in the specifications. Operating the motor in excess of the permissible torque may damage the gearhead.

- **Speed range**

Operate the motor within the speed range in the specifications. Operating the motor beyond the speed range may shorten the life of the gearhead.

- **Backlash**

There is backlash on the gearhead output shaft. To suppress the effect of backlash, perform positioning operation in either the CW or CCW direction.

- **When operating the motor with the key in a state where no load is installed, take precautions to prevent the key from flying off.**

Flying off the key may cause injury or damage to equipment.

- **Peak torque**

For the total torque of the acceleration/deceleration torque when the motor starts/stops and the load (friction) torque, keep the peak torque specified in the specifications. Operating the motor beyond its peak torque may result in damage to the gearhead.

- **Rotation direction of gearhead output shaft**

The rotation direction of the motor output shaft and that of the gearhead output shaft vary as follows depending on the gear ratio of the gearhead.

Gearhead type	Model	Gear ratio	Rotation direction of gearhead output shaft
CS geared	–	All gear ratios	Same direction as the motor output shaft
SH geared	PKP223	7.2, 36	Same direction as the motor output shaft
		9, 10, 18	Opposite direction to the motor output shaft
	PKP243 PKP264	3.6, 7.2, 9, 10	Same direction as the motor output shaft
		18, 36	Opposite direction to the motor output shaft
TS geared	–	3.6, 7.2, 10	Same direction as the motor output shaft
		20, 30	Opposite direction to the motor output shaft
Harmonic geared	–	All gear ratios	Opposite direction to the motor output shaft

■ Notes when the connection cable is used (connector-coupled type only)

● When connecting the connector

Hold the connector body, and insert it straight and secure. Inserting the connector while it is tilted may result in damage to the connector or cause connection failure.

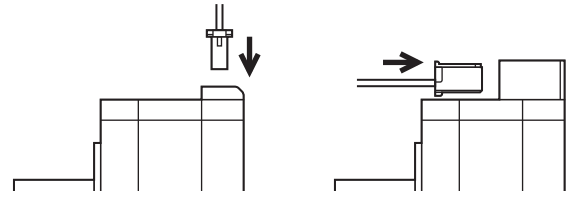

● When disconnecting the connector

For the connection cable with the connector lock, pull out the connector in a straight line while releasing the lock part of the connector. Pulling out the connector while holding the lead wires or while the connector is locked may cause damage to the connector.

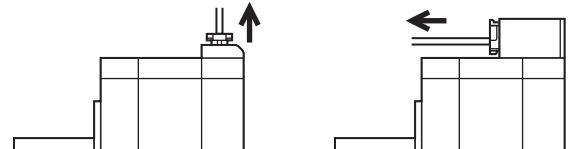

Note Fix the lead wires of the connection part of the connector so that the connector or terminals are not stressed by bending the lead wires or by their own weight. Do not excessively bend the lead wires near the connection part of the connector. Stress on the lead wires may cause poor contact or disconnection, resulting in malfunction or heat generation.

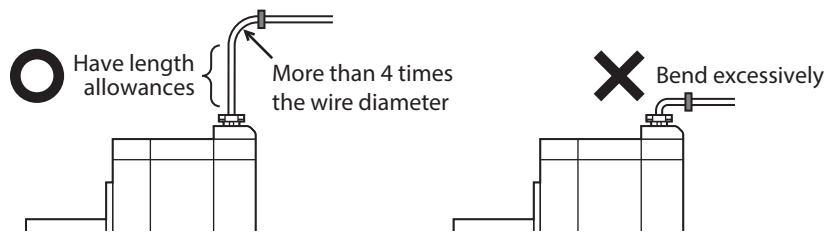

4 Preparation

4-1 Checking the product

Verify that the items listed below are included. Report any missing or damaged items to the Oriental Motor sales office from which you purchased the product.

- Motor 1 unit
- Varistor 1 piece (included with an electromagnetic brake motor)
- Parallel key 1 piece (included with **PKP26-CS** and **PKP56-TS**)
- Motor mounting screw set..... 1 bag (included with **PKP26-CS** and **PKP56-TS**)
 [Package contents]
 - Screw 4 pieces [M4 × 60 mm (2.36 in.)]
 - Flat washer 4 pieces
 - Spring washer 4 pieces
- Connection cable [0.6 m (2 ft.)] 1 piece (included with **PKP□-L**)
- Encoder connection cable [0.6 m (2 ft.)] 1 piece (included with a motor with encoder of **PKP□-L**)
- Instructions and Precautions for Safe Use..... 1 copy

4-2 How to identify the product model

Check the model name of the motor against that shown on the nameplate. Refer to “4-3 Information about nameplate” on p.11 for how to identify the nameplate.

■ Standard type, high-resolution type, high-torque type

● 2-Phase

PKP2 □ □ □ D □□ □ □ □ -R□ □ -L
 1 2 4 5 6 7 8 9 10 11 12

● 5-Phase

PKP5 □ □ □ □ N □□ □ □ □ -R□ □ -L
 1 2 3 4 5 6 7 8 9 10 11 12

1	Motor frame size	0 : 13 mm (0.51 in.) 3 : 35 mm (1.38 in.) 6 : 56.4 mm (2.22 in.)*	1 : 20 mm (0.79 in.) 4 : 42 mm (1.65 in.) 9 : 85 mm (3.35 in.)	2 : 28 mm (1.10 in.) 5 : 50 mm (1.97 in.)
2	Motor case length			
3	Motor classification (PKP56 only)	Blank: Motor frame size 56.4 mm (2.22 in.) F : Motor frame size 60 mm (2.36 in.)		
4	Motor type	Blank: Standard type M : High-resolution type P : High-torque type		
5	Number of lead wires	D : 4 pieces U : 5 pieces or 6 pieces N : 5 pieces		
6	Motor winding specifications	Representative example	05 : Rated current 0.5 A/phase 24 : Rated current 2.4 A/phase	
7	Shape	A : Single shaft B : Double shaft M : With electromagnetic brake		
8	Output shaft diameter	A : Inch size Blank: Millimeter size		
9	Motor identification	Refer to “4-4 Motor model type” on p.11 for the motor model type. <ul style="list-style-type: none"> ● 2-Phase <ul style="list-style-type: none"> 2: Model A, Model B [frame side 28 mm (1.10 in.)], Model D Blank: Model B [frame size 35 mm (1.38 in.), 42 mm (1.65 in.), 56.4 mm (2.22 in.)], Model C ● 5-Phase <ul style="list-style-type: none"> 2: Model A Blank: Model B W: Model C 		
10	Encoder resolution	R3E, R2E : 200 P/R R3F, R2F : 400 P/R R3G, R2G : 500 P/R R3J : 1,000 P/R		
11	Encoder output circuit type	L : Line driver output N : Open-collector output Blank: Voltage output		
12	Connection cable	-L : With a connection cable Blank: Without connection cable		

* For the model name **PKP56□F**, the motor frame size is 60 mm (2.36 in.).

■ **Geared type**

● **2-Phase**

PKP2 □ □ D □□ □ □ - SG □ -R□ □ -L
 1 2 3 4 5 6 8 9 10 11 12

● **5-Phase**

PKP5 □ □ N □□ A 2 - TS □
 1 2 3 4 5 7 8 9

1	Motor frame size	0: 13 mm (0.51 in.) 2: 28 mm (1.10 in.) 4: 42 mm (1.65 in.) 6: 60 mm (2.36 in.)
2	Motor case length	
3	Number of lead wires	D: 4 pieces N: 5 pieces U: 5 pieces or 6 pieces
4	Motor winding specifications	Representative example 15: Rated current 1.5 A/phase 28: Rated current 2.8 A/phase
5	Shape	A: Single shaft B: Double shaft
6	Motor identification	Refer to “4-4 Motor model type” on p.11 for the motor model type. 2: Model A, Model D Blank: Model B
7	Reference number	
8	Gearhead type	CS: CS geared SG: SH geared TS: TS geared H: Harmonic geared
9	Gear ratio	
10	Encoder resolution	R3E, R2E: 200 P/R R3F, R2F: 400 P/R R3G, R2G: 500 P/R R3J: 1,000 P/R
11	Encoder output circuit type	L: Line driver output N: Open-collector output Blank: Voltage output
12	Connection cable	-L: With connection cable Blank: Without connection cable

4-3 Information about nameplate

The figure shows an example.

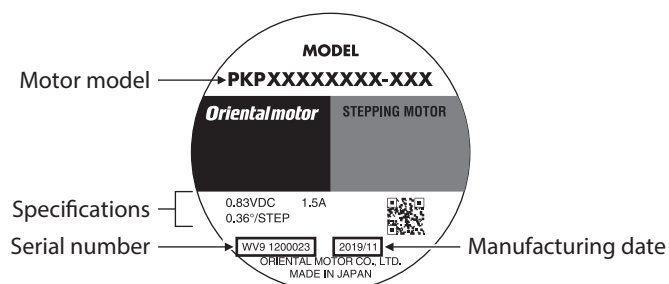

The position describing the information may vary depending on the product.

4-4 Motor model type

■ 2-Phase

The motor model type is determined by the motor shape and the frame size. Check on the following table.

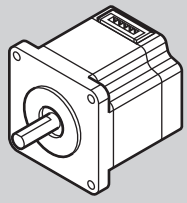
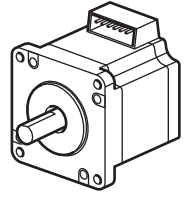
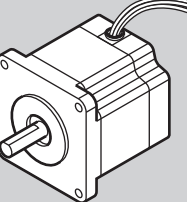
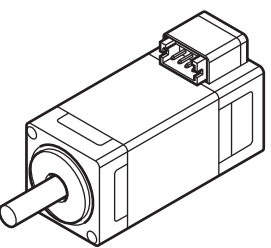
Model type	Motor	Model name
A	Connector-coupled type 	PKP24*1 PKP25 PKP26*1
B	Connector-coupled type 	PKP22 PKP23 PKP24*2 PKP26*2
C	Lead wire type 	PKP21 PKP29
D	Connector-coupled type 	PKP20

*1 Motors that the "motor identification" in the model name is 2

*2 Motors that the "motor identification" in the model name is blank

■ 5-Phase

The motor model type is determined by “motor identification” in the model name. Refer to “4-5 Names of parts” for the motor shape.

Model type	Motor identification
A	2
B	Blank
C	W

4-5 Names of parts

■ Model A motor (connector-coupled type)

The figure shows the **PKP264U20A2**.

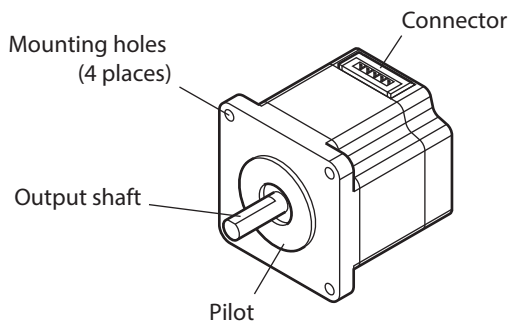

● Connection cables

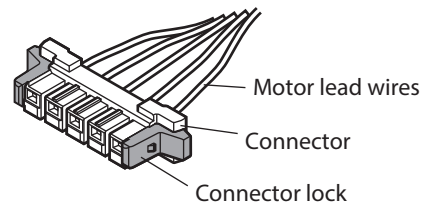

■ Model B motor (connector-coupled type)

The figure shows the **PKP264U20A**.

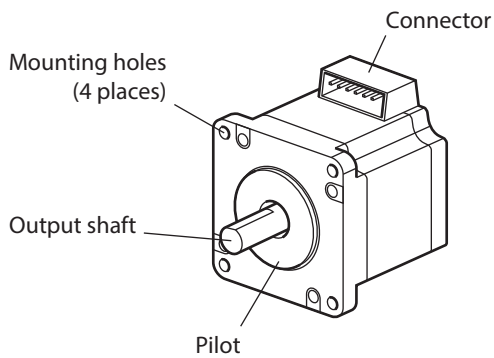

● Connection cables

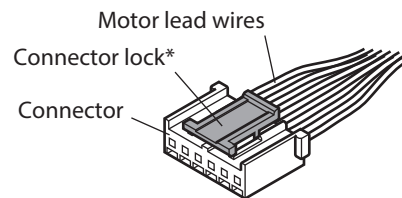

* The connection cable for **PKP22** does not have it.

■ Model C motor (lead wire type)

The figure shows the **PKP296U20A**.

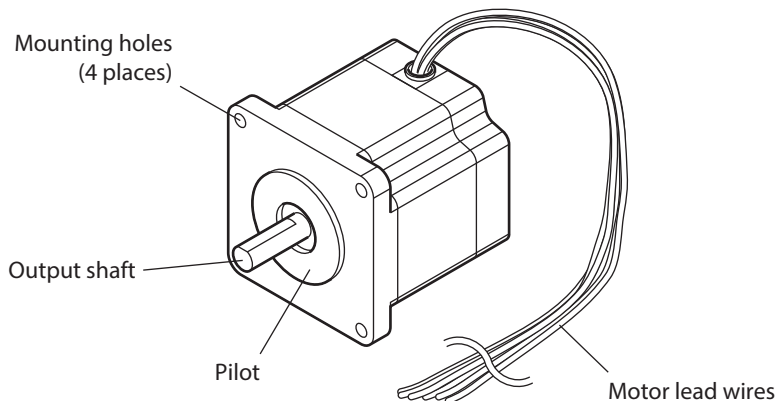

■ Model D motor (connector-coupled type)

The figure shows the **PKP203D06A2**.

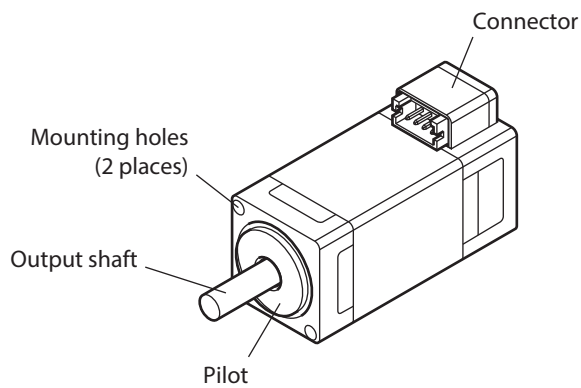

● Connection cables

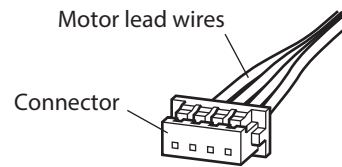

■ Electromagnetic brake

● Connector-coupled type

The figure shows the **PKP243D23M2**.

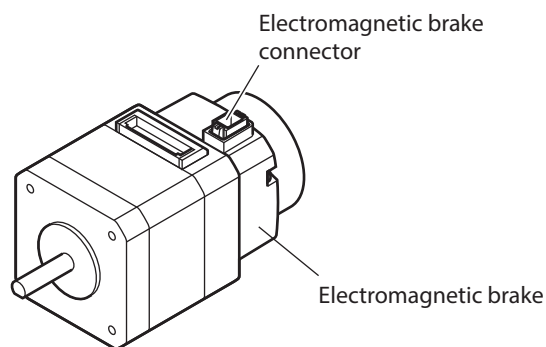

Electromagnetic brake connection cable

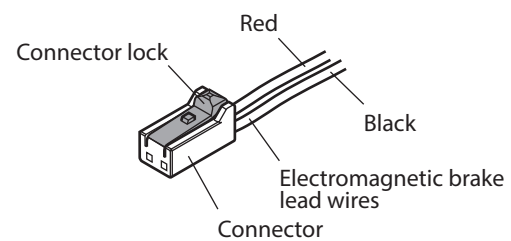

● Lead wire type

The figure shows the **PKP243D15M**.

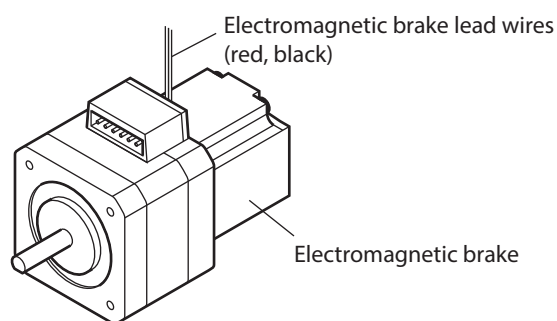

5 Installation

5-1 Installation location

The motor is designed and manufactured to be incorporated into equipment. Install it in a well-ventilated location that provides easy access for inspection. The location must also satisfy the following conditions:

- Inside an enclosure that is installed indoors (provide vent holes)
- Operating ambient temperature: -10 to $+50$ °C ($+14$ to 122 °F) (non-freezing)
0 to $+40$ °C ($+32$ to 104 °F) (non-freezing) for harmonic geared type
- Operating ambient humidity: 85 % or less (non-condensing)
- Area free of explosive atmosphere, toxic gas (such as sulfuric gas), or liquid
- Area not exposed to direct sun
- Area free of excessive amount of dust, iron particles or the like
- Area not subject to splashing water (rain, water droplets), oil (oil droplets) or other liquids
- Area free of excessive salt
- Area not subject to continuous vibration or excessive shocks
- Area free of excessive electromagnetic noise (from welders, power machinery, etc.)
- Area free of radioactive materials, magnetic fields, or vacuum
- Up to 1,000 m (3,300 ft.) above sea level

5-2 Installation method

There is no restriction on the direction in which the motor can be installed.

Install the motor onto an appropriate flat metal plate having excellent vibration resistance and heat conductivity.

When installing the motor, use all mounting holes to secure the motor with screws (*) so that there is no gap between the motor and the metal plate.

* The motor mounting screw set is included with **PKP26-CS** and **PKP56-TS** only.

● Installation method 1

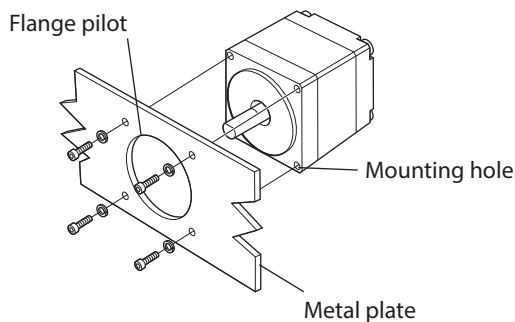

● Installation method 2

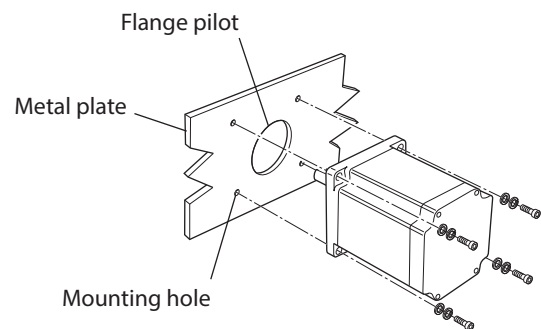

■ Screw size, tightening torque, installation method

The values of the tightening torque are recommended. Tighten the screws to an appropriate torque according to the design conditions of the metal plate being installed.

● Standard type, high-resolution type, high-torque type

Model	Nominal designation of thread	Tightening torque [N·m (oz-in)]	Effective depth of screw thread [mm (in.)]	Installation method
PKP20	M1.6	0.043 (6.1)	4 (0.16)	1
PKP21	M2 P0.4	0.25 (35)	2.5 (0.1)	
PKP22	M2.5 P0.45	0.5 (71)	2.5 (0.1)	
PKP23, PKP24	M3 P0.5	1 (142)	4.5 (0.18)	
PKP25, PKP26	M4	2 (280)	–	2
PKP29	M5	3 (420)	–	
PKP52	M2.5	0.5 (71)	2.5 (0.1)	1
PKP54	M3	1 (142)	4.5 (0.18)	
PKP56	M4	2 (280)	–	2

● Geared type

Gearhead type	Model	Nominal designation of thread	Tightening torque [N·m (oz-in)]	Effective depth of screw thread [mm (in.)]	Installation method
CS geared	PKP22	M3	1 (142)	6 (0.24)	1
	PKP24	M4	2 (280)	8 (0.31)	
	PKP26	M4	2 (280)	–	2
SH geared	PKP22	M2.5 P0.45	0.5 (71)	4 (0.16)	1
	PKP24	M3 P0.5	1 (142)	7 (0.28)	
	PKP26	M4 P0.7	2 (280)	8 (0.31)	
TS geared	PKP54	M4	2 (280)	8 (0.31)	1
	PKP56	M4	2 (280)	–	2
Harmonic geared	PKP20	M1.6	0.26 (36)	3.2 (0.13)	1



Note Do not loosen the screws (4 pieces) that secure the gearhead to the motor. Doing so may result in reduced accuracy or damage to the product.

5-3 Installing a load

When installing a load on the motor, align the axis of rotation of the output shaft with that of the load. When installing a coupling or pulley on the output shaft, be careful not to damage to the output shaft or the bearing (ball bearings).

5-4 Permissible radial load and permissible axial load

Make sure that the radial load and axial load applied to the output shaft are equal to or less than the permissible values shown in the table below.

■ Standard type, high-resolution type, high-torque type

Model type	Model	Permissible radial load [N (lb.)]					Permissible axial load [N (lb.)]
		Distance from output shaft end [mm (in.)]					
		0 (0)	5 (0.20)	10 (0.39)	15 (0.59)	20 (0.79)	
A	PKP24*1	35 (7.8)	44 (9.9)	58 (13)	85 (19.1)	–	15 (3.3)
	PKP24*2	90 (20)	100 (22)	130 (29)	180 (40)	–	
	PKP25	61 (13.7)	73 (16.4)	90 (20)	110 (24)	–	20 (4.5)
	PKP26*3	61 (13.7)	73 (16.4)	90 (20)	140 (31)	–	30 (6.7)
	PKP26*2	90 (20)	100 (22)	130 (29)	180 (40)	270 (60)	
	PKP54	35 (7.8)	44 (9.9)	58 (13)	85 (19.1)	–	15 (3.3)
	PKP56*3	61 (13.7)	73 (16.4)	90 (20)	140 (31)	–	30 (6.7)
	PKP56*2	90 (20)	100 (22)	130 (29)	180 (40)	270 (60)	
B, C	PKP21	12 (2.7)	15 (3.3)	–	–	–	3 (0.67)
	PKP22	25 (5.6)	34 (7.6)	52 (11.7)	–	–	5 (1.12)
	PKP23 PKP24	20 (4.5)	25 (5.6)	34 (7.6)	52 (11.7)	–	10 (2.2)
	PKP26*3	49 (11)	60 (13.5)	79 (17.7)	110 (24)	–	20 (4.5)
	PKP26*2	61 (13.7)	73 (16.4)	90 (20)	110 (24)	160 (36)	
	PKP29	260 (58)	290 (65)	340 (76)	390 (87)	480 (108)	60 (13.5)
	PKP52	25 (5.6)	34 (7.6)	52 (11.7)	–	–	5 (1.12)
	PKP54	20 (4.5)	25 (5.6)	34 (7.6)	52 (11.7)	–	10 (2.2)
	PKP56	63 (14.1)	75 (16.8)	95 (21)	130 (29)	190 (42)	20 (4.5)
	PKP56□M	90 (20)	100 (22)	130 (29)	180 (40)	270 (60)	
D	PKP20	5 (1.12)	6 (1.35)	–	–	–	1 (0.22)

*1 When the output shaft diameter is $\varnothing 5$ mm (0.20 in.)

*2 When the output shaft diameter is $\varnothing 8$ mm (0.31 in.)

*3 When the output shaft diameter is $\varnothing 6.35$ mm (0.25 in.)

■ Geared type

Gearhead type	Model	Gear ratio	Permissible radial load [N (lb.)]					Permissible axial load [N (lb.)]
			Distance from output shaft end [mm (in.)]					
			0 (0)	5 (0.20)	10 (0.39)	15 (0.59)	20 (0.79)	
CS geared	PKP223	All gear ratios	30 (6.7)	37 (8.3)	50 (11.2)	73 (16.4)	–	30 (6.7)
	PKP243	All gear ratios	59 (13.2)	68 (15.3)	80 (18)	96 (21)	–	40 (9)
	PKP264	All gear ratios	160 (36)	170 (38)	200 (45)	220 (49)	260 (58)	70 (15.7)
SH geared	PKP223	All gear ratios	15 (3.3)	17 (3.8)	20 (4.5)	23 (5.1)	–	10 (2.2)
	PKP243	All gear ratios	10 (2.2)	15 (3.3)	20 (4.5)	30 (6.7)	–	15 (3.3)
	PKP264	3.6, 7.2, 9, 10	30 (6.7)	40 (9)	50 (11.2)	60 (13.5)	70 (15.7)	30 (6.7)
		18, 36	80 (18)	100 (22)	120 (27)	140 (31)	160 (36)	
TS geared	PKP543	20, 30	40 (9)	50 (11.2)	60 (13.5)	70 (15.7)	–	15 (3.3)
	PKP544	3.6, 7.2, 10	20 (4.5)	30 (6.7)	40 (9)	50 (11.2)	–	
	PKP564	20, 30	170 (38)	185 (41)	200 (45)	215 (48)	230 (51)	40 (9)
	PKP566	3.6, 7.2, 10	120 (27)	135 (30)	150 (33)	165 (37)	180 (40)	
Harmonic geared	PKP203	All gear ratios	28 (6.3)	36 (8.1)	–	–	–	40 (9)

6 Connection

When connecting a motor to an Oriental Motor driver, refer to the operating manual of the driver.

6-1 Connecting 2-phase stepping motors

Pin numbers and lead wire colors are shown in the figures.
The lead wire colors indicate the color combination of the Oriental Motor connection cable.

■ Model A motor (connector-coupled type)

● Connection diagram

Unipolar (5 lead wires type)

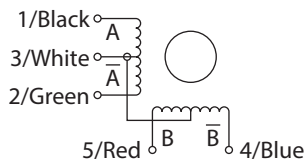

Bipolar (4 lead wires type)*

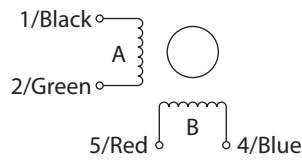

* Pin No. 3 is not used for the 4 lead wires type.

● Pin arrangements

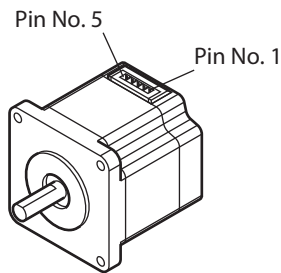

Connection cable

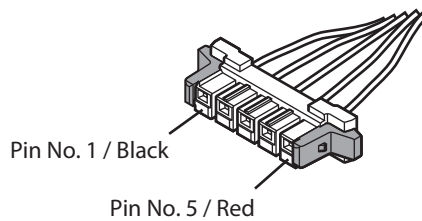

● Applicable connector and lead wire

Manufacturer: HIROSE ELECTRIC CO., LTD.

Connector housing	MDF97A-5S-3.5C
Contact	MDF97-22SC
Designated crimp tool	HT801/MDF97-22S
Applicable lead wire	<ul style="list-style-type: none"> • Conductor size: AWG 24 to AWG 22 (0.2 to 0.3 mm²) • Outer diameter of wire insulation: ø1.24 to 1.38 mm (ø0.049 to 0.054 in.) • Stripping length of wire insulation: 1.8 to 2.3 mm (0.071 to 0.091 in.)

■ Model B motor (connector-coupled type)

● Connection diagram

Unipolar (6 lead wires type)

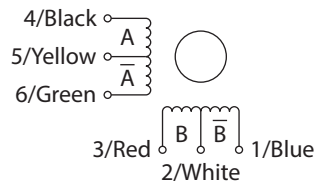

Bipolar (4 lead wires type)*

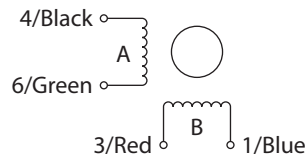

* Pin No. 2 and No. 5 are not used for the 4 lead wires type.

● Pin arrangements

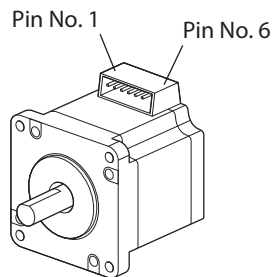

Connection cables

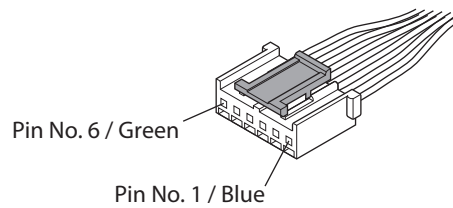

● Applicable connector and lead wire

PKP22

Manufacturer: Molex, LLC

Connector housing	51065-0600
Contact	50212-8XXX
Designated crimp tool	57176-5000 or 63819-0500
Applicable lead wire	<ul style="list-style-type: none"> • Conductor size <ul style="list-style-type: none"> Setting current less than 1 A/phase: AWG 28 to AWG 24 (0.08 to 0.2 mm²) Setting current 1 A/phase or more: AWG 26 to AWG 24 (0.14 to 0.2 mm²) Setting current 1.5 A/phase or more: AWG 24 (0.2 mm²) • Outer diameter of wire insulation: ø0.8 to 1.4 mm (ø0.031 to 0.055 in.) • Stripping length of wire insulation: 1.3 to 1.8 mm (0.051 to 0.071 in.)

PKP23, PKP24

There are two types of applicable connectors. Use either one shown in the table.
 Be sure to use a connector housing, contact, and designated crimp tool in the combinations shown in the table.
 Manufacturer: Molex, LLC

Applicable connector 1	Connector housing	51103-0600
	Contact	50351-8XXX
	Designated crimp tool	57295-5000 or 63811-8100
	Conductor size	<ul style="list-style-type: none"> Conductor size Setting current less than 1.5 A/phase: AWG 28 to AWG 22 (0.08 to 0.3 mm²) Setting current 1.5 A/phase or more: AWG 26 to AWG 22 (0.14 to 0.3 mm²) Setting current 2 A/phase or more: AWG 24 to AWG 22 (0.2 to 0.3 mm²) Outer diameter of wire insulation: \varnothing1.15 to 1.8 mm (\varnothing0.045 to 0.071 in.) Stripping length of wire insulation: 2.3 to 2.8 mm (0.091 to 0.11 in.)
Applicable connector 2	Connector housing	51163-0600
	Contact	AWG 22 to 20: 50752-8200 AWG 26 to 24: 50752-8400
	Designated crimp tool	AWG 22 to 20: 200218-4900 AWG 26 to 24: 200218-9200
	Conductor size	<ul style="list-style-type: none"> Conductor size Setting current less than 2 A/phase: AWG 26 to AWG 20 (0.14 to 0.5 mm²) Setting current 2 A/phase or more: AWG 24 to AWG 20 (0.2 to 0.5 mm²) Outer diameter of wire insulation: \varnothing1.15 to 1.8 mm (\varnothing0.045 to 0.071 in.) Stripping length of wire insulation: 2.3 to 2.8 mm (0.091 to 0.11 in.)

PKP26

Manufacturer: Molex, LLC

Connector housing	51067-0600
Contact	50217-9XXX
Designated crimp tool	57189-5000, 57190-5000, or 63811-8300
Applicable lead wire	<ul style="list-style-type: none"> Conductor size: AWG 24 to AWG 18 (0.2 to 0.75 mm²) Outer diameter of wire insulation: \varnothing1.4 to 3 mm (\varnothing0.055 to 0.118 in.) Stripping length of wire insulation: 3 to 3.5 mm (0.118 to 0.138 in.)

■ **Model C motor (lead wire type)**

● **Connection diagram**

Unipolar (5 lead wires type)

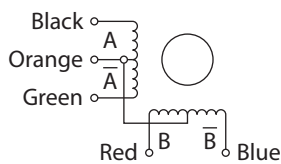

Unipolar (6 lead wires type)

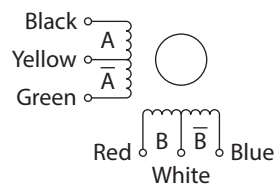

Bipolar (4 lead wires type)

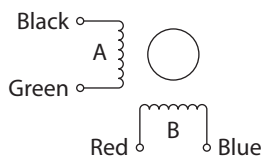

■ Model D motor (connector-coupled type)

● Connection diagram

Bipolar (4 lead wires type)

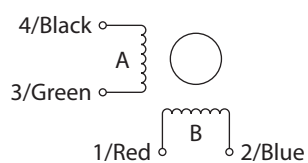

● Pin arrangements

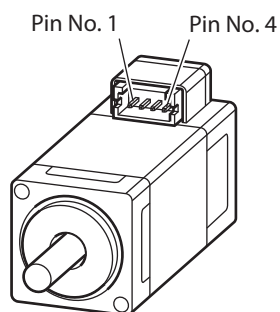

Connection cables

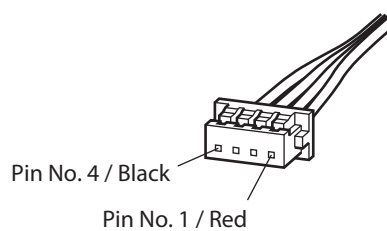

● Applicable connector and lead wire

Manufacturer: HIROSE ELECTRIC CO., LTD.

Connector housing	DF13-4S-1.25C
Contact	DF13-2630SCF
Designated crimp tool	AP105-DF13-2630S or DF13-TB2630HC
Applicable lead wire	<ul style="list-style-type: none"> • Conductor size: AWG 30 to AWG 26 (0.055 to 0.141 mm²) • Outer diameter of wire insulation: ø0.56 to 1.0 mm (ø0.022 to 0.039 in.) • Stripping length of wire insulation: 1.2 to 1.9 mm (0.047 to 0.075 in.)

6-2 Connecting 5-phase stepping motors

Pin numbers and lead wire colors are shown in the figures.
The lead wire colors indicate the color combination of the Oriental Motor connection cable.

■ Model A motor (connector-coupled type)

● Pin assignments

Pin number	Color of lead wire
5	Blue
4	Red
3	Orange
2	Green
1	Black

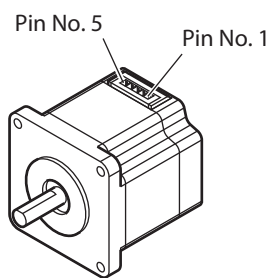

Connection cables

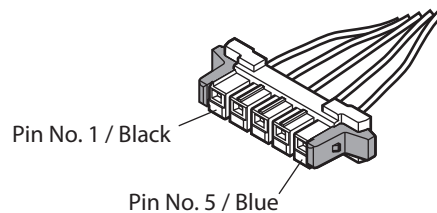

● Applicable connector and lead wire

Manufacturer: HIROSE ELECTRIC CO., LTD.

Connector housing	MDF97A-5S-3.5C
Contact	MDF97-22SC
Designated crimp tool	HT801/MDF97-22S
Applicable lead wire	<ul style="list-style-type: none"> • Conductor size: AWG 24 to AWG 22 (0.2 to 0.3 mm²) • Outer diameter of wire insulation: ø1.24 to 1.38 mm (ø0.049 to 0.054 in.) • Stripping length of wire insulation: 1.8 to 2.3 mm (0.071 to 0.091 in.)

■ Model B motor (connector-coupled type)

● Pin assignments

Pin number	Color of lead wire
1	Blue
2	Red
3	Orange
4	Green
5	Black

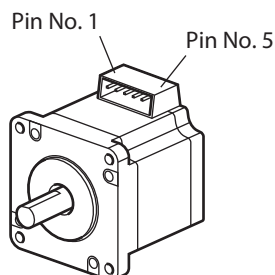

Connection cables

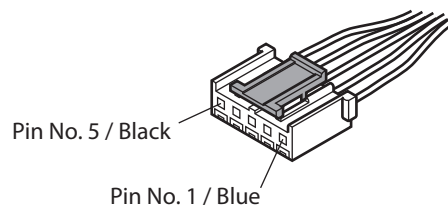

● **Applicable connector and lead wire**

PKP52

Manufacturer: Molex, LLC

Connector housing	51065-0500
Contact	50212-8XXX
Designated crimp tool	57176-5000 or 63819-0500
Applicable lead wire	<ul style="list-style-type: none"> • Conductor size: AWG 26 to AWG 24 (0.14 to 0.2 mm²) • Outer diameter of wire insulation: ø1.4 mm (ø0.055 in.) or less • Stripping length of wire insulation: 1.3 to 1.8 mm (0.051 to 0.071 in.)

PKP54

There are two types of applicable connectors. Use either one shown in the table.

Be sure to use a connector housing, contact, and designated crimp tool in the combinations shown in the table.

Manufacturer: Molex, LLC

Applicable connector 1	Connector housing	51103-0500
	Contact	50351-8XXX
	Designated crimp tool	57295-5000 or 63811-8100
	Conductor size	<ul style="list-style-type: none"> • Conductor size: AWG 24 to AWG 22 (0.2 to 0.3 mm²) • Outer diameter of wire insulation: ø1.15 to 1.8 mm (ø0.045 to 0.071 in.) • Stripping length of wire insulation: 2.3 to 2.8 mm (0.091 to 0.11 in.)
Applicable connector 2	Connector housing	51163-0500
	Contact	AWG 22 to 20: 50752-8200 AWG 26 to 24: 50752-8400
	Designated crimp tool	AWG 22 to 20: 200218-4900 AWG 26 to 24: 200218-9200
	Conductor size	<ul style="list-style-type: none"> • Conductor size: AWG 24 to AWG 20 (0.2 to 0.5 mm²) • Outer diameter of wire insulation: ø1.15 to 1.8 mm (ø0.045 to 0.071 in.) • Stripping length of wire insulation: 2.3 to 2.8 mm (0.091 to 0.11 in.)

PKP56

Manufacturer: J.S.T. Mfg. Co., Ltd.

Connector housing	VHR-5N
Contact	BVH-21T-P1.1
Designated crimp tool	<ul style="list-style-type: none"> • AWG 22: YC-160R • AWG 20: YC-160R or YC-161R • AWG 18: YC-161R
Applicable lead wire	<ul style="list-style-type: none"> • Conductor size: AWG 22 to AWG 18 (0.33 to 0.83 mm²) • Outer diameter of wire insulation: ø1.7 to 3.0 mm (ø0.067 to 0.118 in.) • Stripping length of wire insulation: 3.0 to 3.5 mm (0.118 to 0.138 in.)

6-3 Connecting the encoder section

Note Use a shielded cable to extend the wiring or reduce the influence of noise. Also, keep the encoder connection cable as far away as possible from power lines, such as motor and power supply, and wire it at the shortest possible distance.

■ Model A, B, and C motors

● Pin assignments

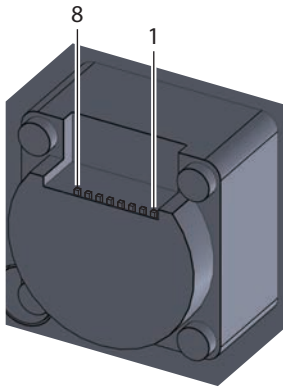

Pin number	Lead wire color*	Signal name		Function
		Line driver output	Voltage output	
8	White	Vcc	Vcc	Power supply input (+5 V)
7	Orange	Z-	N.C.	Phase Z output negative side
6	Yellow	Z+	Z	Phase Z output positive side
5	Blue	B-	N.C.	Phase B output negative side
4	Green	B+	B	Phase B output positive side
3	Brown	A-	N.C.	Phase A output negative side
2	Red	A+	A	Phase A output positive side
1	Black	GND	GND	Power supply input (Ground)

* It indicates the colors of the lead wires for the encoder connection cable of Oriental Motor.

● Applicable connector and lead wire

Manufacturer: Molex, LLC

Connector housing	51021-0800
Contact	50079-8X00
Designated crimp tool	57177-5000 or 200218-1900
Applicable lead wire	<ul style="list-style-type: none"> ● Conductor size: AWG 28 to AWG 26 (0.08 to 0.128 mm²) ● Outer diameter of wire insulation: ø0.5 to 1.04 mm (ø0.02 to 0.04 in.) ● Stripping length of wire insulation: 1.4 to 1.9 mm (0.06 to 0.07 in.)

■ Model D motor

● Pin assignments

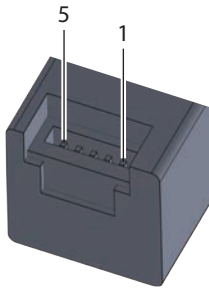

Pin number	Color of lead wire*	Signal name	Function
5	Black	GND	Power supply input (Ground)
4	White	Vcc	Power supply input (+5 V)
3	Yellow	Z	Phase Z output
2	Green	B	Phase B output
1	Red	A	Phase A output

* It indicates the colors of the lead wires for the encoder connection cable of Oriental Motor.

● Applicable connector and lead wire

Manufacturer: Molex, LLC

Connector housing	505565-0501
Contact	505431-1100, 505431-1200 or 505431-1300
Designated crimp tool	200218-0300
Applicable lead wire	<ul style="list-style-type: none"> • Conductor size: AWG30 to AWG 26 (0.049 to 0.136 mm²) • Outer diameter of wire insulation: ø0.78 to 1.02 mm (ø0.031 to 0.04 in.) • Stripping length of wire insulation: 1.4 to 1.6 mm (0.055 to 0.063 in.)

■ Specifications

● When the output circuit type is line driver output (equivalent to 26C31)

Item	Model name indicating the resolution and output circuit type			
	R3EL, R2EL	R3FL, R2FL	R3GL, R2GL	R3JL
Resolution (P/R)	200	400	500	1,000
Output type	Incremental			
Output circuit				
Output signal	Phase A, Phase B, Phase Z: 3 Channels			
Maximum sink current	20 mA			
Output voltage	H level	2.5 V or more		
	L level	0.5 V or less		
Response frequency	200 kHz or less			
Power supply voltage	5 VDC±10 %			
Current consumption (no load)	30 mA or less			
Angular accuracy*	±0.36° (conversion value at motor output shaft)			

* Only when **R3** is included in the model name indicating resolution

● When the output circuit type is voltage output

Item	Model name indicating the resolution and output circuit type			
	R3E, R2E	R3F, R2F	R3G, R2G	R3J
Resolution (P/R)	200	400	500	1,000
Output type	Incremental			
Output circuit				
Output signal	Phase A, Phase B, Phase Z: 3 Channels			
Maximum sink current	20 mA			
Output voltage	H level	4.3 V or more (no load)		
	L level	0.5 V or less		
Response frequency	100 kHz or less			
Power supply voltage	5 VDC±10 %			
Current consumption (no load)	45 mA or less			
Angular accuracy*	±0.36° (conversion value at motor output shaft)			

* Only when **R3** is included in the model name indicating resolution

● When the output circuit type is open-collector output

Item	Model name indicating the resolution and output circuit type		
	R3EN	R3FN	R3JN
Resolution (P/R)	200	400	1,000
Output type	Incremental		
Output circuit			
Output signal	Phase A, Phase B, Phase Z: 3 Channels		
Maximum sink current	20 mA		
Output voltage	H level	-	
	L level	0.5 V or less	
Response frequency	100 kHz or less		
Power supply voltage	5 VDC±10 %		
Current consumption (no load)	40 mA or less		
Angular accuracy	±0.36° (conversion value at motor output shaft)		

■ **Output waveform, waveform accuracy**

- **When R3 is included in the model name indicating resolution**

Output waveform

“High” and “Low” in the timing chart represent the voltage state of the output terminals.

For the open-collector output, they represent the voltage state of the output terminals when connected as shown in the figure on the right.

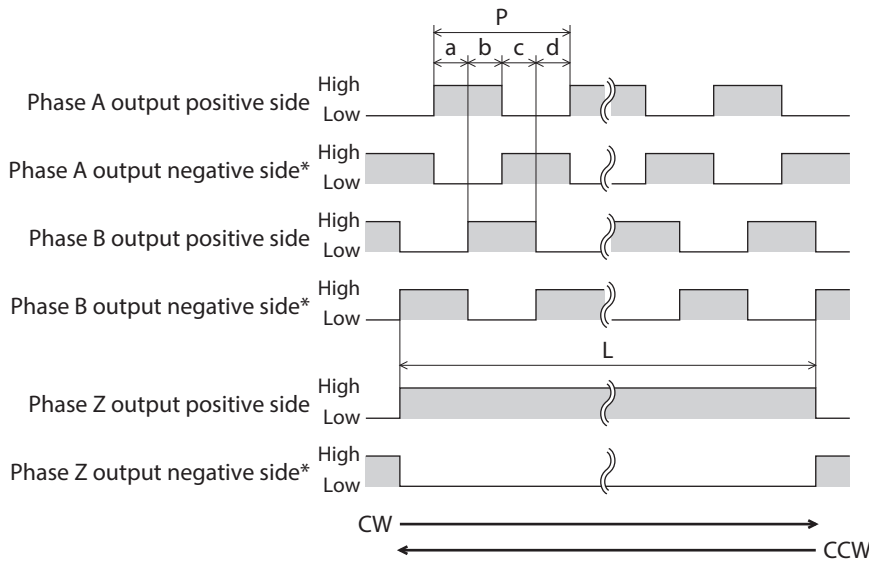
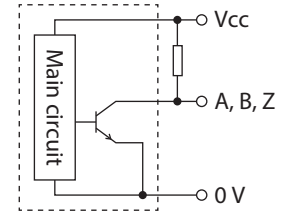

* Line driver output only

Waveform accuracy

- Duty ratio: 50 %±12.5 % for both phase A output and phase B output
- Phase Z output (standard type): $L^* = (\text{encoder resolution}/50) \times P$
 Phase Z output (high resolution type): $L^* = (\text{encoder resolution}/100) \times P$
 * 7.2° when converted to the motor output shaft (3.6° for high-resolution type)
- Phase difference: $a, b, c, d = P/4 \pm P/8$
- Rise and fall time of signal: 1 μs or less (at connector terminal)

● When R2 is included in the model name indicating resolution

Output waveform

● When rotating in the CW direction

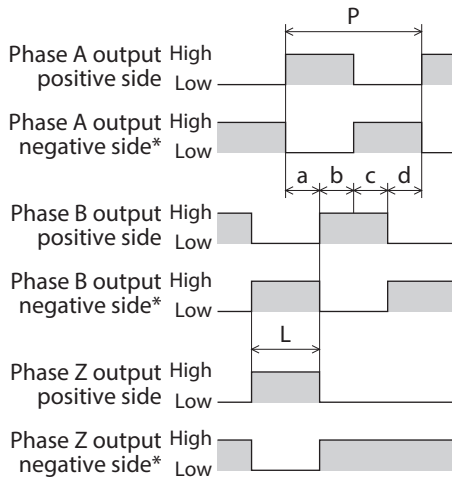

● When rotating in the CCW direction

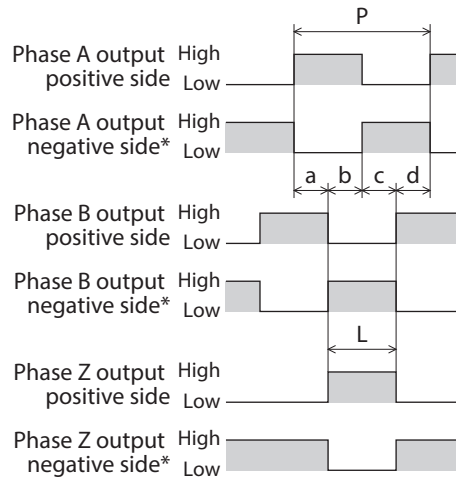

* Line driver output only

Waveform accuracy

- Duty ratio: 50 %±12.5 % for both phase A output and phase B output
- Phase Z output: $P/4 \leq L \leq 3P/4$
- Phase difference: $a, b, c, d = P/4 \pm P/8$
- Rise and fall time of signal: 1 μ s or less (at connector terminal)

6-4 Connecting the electromagnetic brake section

■ Specifications of an electromagnetic brake connection cable

● Connector pin arrangement

The figure shows the view from the insertion side of lead wires.

Pin number	Color of lead wire
2	Black
1	Red

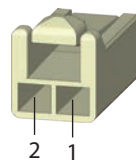

● Applicable connector and lead wire

Manufacturer: HIROSE ELECTRIC CO., LTD.

Connector housing	DF62C-2S-2.2C
Contact	DF62-22SCA
Designated crimp tool	HT801/DF62-22 (10)
Applicable lead wire	<ul style="list-style-type: none"> ● Conductor size: AWG 22 (0.3 mm²) ● Outer diameter of wire insulation: ϕ1.2 to 1.45 mm (ϕ0.047 to 0.057 in.) ● Stripping length of wire insulation: 1.7 to 2.3 mm (0.067 to 0.091 in.)

■ Specifications of a power supply for electromagnetic brake

Connection type of electromagnetic brake	Model	Power supply voltage	Current capacity
Connector-coupled type	PKP24	24 VDC±5 %	0.07 A or more
	PKP26		0.18 A or more
Lead wire type	PKP22		0.05 A or more
	PKP23, PKP24		0.07 A or more
	PKP26		0.23 A or more

■ Connection of a power supply for the electromagnetic brake and release of the electromagnetic brake

1. For the connector-coupled type, connect the electromagnetic brake connection cable to the electromagnetic brake connector.

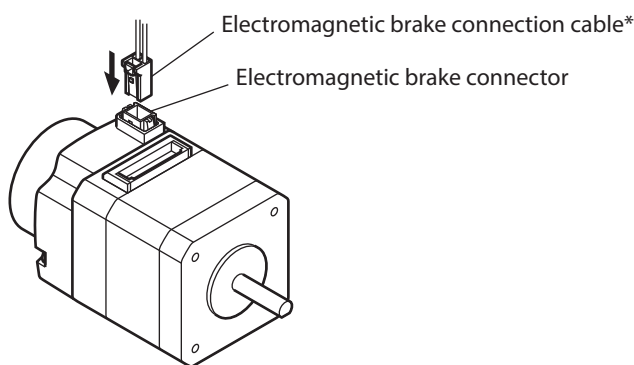

* It is provided in Oriental Motor products.

2. Connect the included varistor in parallel between the 24 VDC terminal and the ground (GND) terminal. The varistor has no polarity.
3. Connect the electromagnetic brake lead wires to a 24 VDC power supply. Connect the red lead wire to the 24 VDC terminal and the black lead wire to the ground (GND) terminal.

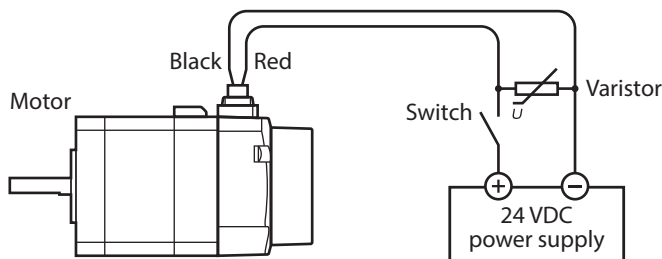

4. Turn on the 24 VDC power supply. The electromagnetic brake is released.

Note

- Do not apply voltage in excess of the specified value. Doing so may increase the heat generation of the electromagnetic brake, resulting in damage to the motor. On the contrary, too low a voltage may not release the electromagnetic brake.
- Be sure to connect a varistor to protect the contact of the switch and prevent noise. [Recommended varistor: Z15D121 (SEMITEC Corporation)]
- Since the electromagnetic brake lead wires have polarity, be sure to connect them with the correct polarity. If the lead wires are connected with reversed polarity, the electromagnetic brake will not operate properly.

7 Inspection and maintenance

7-1 Inspection

It is recommended that the following items be checked periodically after each operation of the motor. If any abnormality occurs, discontinue use of the product and contact your nearest Oriental Motor sales office.

Inspection items

- Check to see if any of the mounting screws of the motor are loose.
- Check to see if the bearing (ball bearings) of the motor generates unusual noises.
- Check to see if the lead wire or cable is not damaged or stressed.
- Check to see if any of the connection parts with the connector or the driver are loose.
- Check to see if the output shaft and the load shaft are not misaligned.

7-2 Warranty

Check on the Oriental Motor Website for the product warranty.

7-3 Disposal

Dispose the product correctly in accordance with laws and regulations, or instructions of local governments.

8 Specifications

8-1 Product specifications

Check on the Oriental Motor Website for the product specifications.

8-2 General specifications

Operating environment	Ambient temperature	-10 to +50 °C (+14 to +122 °F) (non-freezing) 0 to +40 °C (+32 to 104 °F) (non-freezing) for harmonic geared type
	Humidity	85 % or less (non-condensing)
	Altitude	Up to 1,000 m (3,300 ft.) above sea level
	Surrounding atmosphere	No corrosive gas or dust. No exposure to water or oil.
Storage environment Shipping environment	Ambient temperature	-20 to +60 °C (-4 to +140 °F) (non-freezing)
	Humidity	85 % or less (non-condensing)
	Altitude	Up to 3,000 m (10,000 ft.) above sea level
	Surrounding atmosphere	No corrosive gas or dust. No exposure to water or oil.
Degree of protection		IP20
Insulation resistance		100 MΩ or more when 500 VDC megger (100 VDC megger for PKP20) is applied between the windings and the case.
Dielectric strength		Sufficient to withstand the following between the windings and the case for 1 minute. <ul style="list-style-type: none"> • PKP20: 0.3 kVAC 50/60 Hz • PKP21, PKP22, PKP23, PKP24, PKP52, PKP54: 0.5 kVAC 50/60 Hz • PKP25, PKP26: 1.0 kVAC 50/60 Hz • PKP29, PKP56*: 1.5 kVAC 50/60 Hz

* 1.0 kVAC 50/60 Hz for Model A motors

9 Regulations and standards

9-1 Hazardous substances

This product does not contain substances that exceed the regulation values in the RoHS Directive.

- Unauthorized reproduction or copying of all or part of this manual is prohibited.
If a new copy is required to replace an original manual that has been damaged or lost, please contact your nearest Oriental Motor sales office.
- Oriental Motor shall not be liable whatsoever for any problems relating to industrial property rights arising from use of any information, circuit, equipment or device provided or referenced in this manual.
- Characteristics, specifications and dimensions are subject to change without notice.
- While we make every effort to offer accurate information in the manual, we welcome your input. Should you find unclear descriptions, errors or omissions, please contact the nearest office.
- **Orientalmotor** is a registered trademark or trademark of Oriental Motor Co., Ltd., in Japan and other countries.
Other product names and company names mentioned in this manual may be registered trademarks or trademarks of their respective companies and are hereby acknowledged. The third-party products mentioned in this manual are recommended products, and references to their names shall not be construed as any form of performance guarantee. Oriental Motor is not liable whatsoever for the performance of these third-party products.

© Copyright ORIENTAL MOTOR CO., LTD. 2024

Published in January 2026

- Please contact your nearest Oriental Motor office for further information.

ORIENTAL MOTOR U.S.A. CORP.
Technical Support Tel:800-468-3982
8:30am EST to 5:00pm PST (M-F)

ORIENTAL MOTOR (EUROPA) GmbH
Schiesstraße 44, 40549 Düsseldorf, Germany
Technical Support Tel:00 800/22 55 66 22

ORIENTAL MOTOR (UK) LTD.
Blythe Valley Business Park,
Central Blvd Blythe Valley Park,
Solihull B90 8AG, United Kingdom
Tel:+44-1926-671220

ORIENTAL MOTOR (FRANCE) SARL
Tel:+33-1 47 86 97 50

ORIENTAL MOTOR ITALIA s.r.l.
Tel:+39-02-93906347

ORIENTAL MOTOR ASIA PACIFIC PTE. LTD.
Singapore
Tel:1800-842-0280

ORIENTAL MOTOR (MALAYSIA) SDN. BHD.
Tel:1800-806-161

ORIENTAL MOTOR (THAILAND) CO., LTD.
Tel:1800-888-881

ORIENTAL MOTOR (INDIA) PVT. LTD.
Tel:1800-120-1995 (For English)
1800-121-4149 (For Hindi)

TAIWAN ORIENTAL MOTOR CO., LTD.
Tel:0800-060708

SHANGHAI ORIENTAL MOTOR CO., LTD.
Tel:400-820-6516

INA ORIENTAL MOTOR CO., LTD.
Korea
Tel:080-777-2042

ORIENTAL MOTOR CO., LTD.
4-8-1 Higashiueno, Taito-ku, Tokyo
110-8536 Japan
Tel:+81-3-6744-0361
www.orientalmotor.co.jp/ja