



Thank you for purchasing ORIENTAL MOTOR products. Please read this operating manual thoroughly before installing and operating the motor, and always keep the manual where it is readily accessible.

## Motor with Electromagnetic Clutch and Brake

# C - B Motors

Lead Wire Type

© Copyright ORIENTAL MOTOR CO., LTD. 2008

# OPERATING MANUAL

<Table of contents>

1. Precautions .....	Page 1	5. Time Rating .....	Page 3
2. Checking the package contents .....	Page 1	6. Locked rotor burnout protection .....	Page 4
3. Installation .....	Page 2	7. Troubleshooting .....	Page 4
4. Connection and Operation .....	Page 3		

## 1. Precautions

### 1.1 Precautions for Installation

- Do not use in a place where there is flammable gas and /or corrosive gas.
- When installing the motor into your equipment, ensure that the motor lead wires are fixed and do not move. In addition, do not apply any pressure to these lead wires.
- The motor is class I equipment.  
The motor housing must be mounted with a screw and spring washer to the ground point of the equipment.
- Installation must be performed by a qualified installer.

### 1.2 Precautions for Operation

- The Motor case temperature can exceed 70°C (depending on operation conditions).  
In case motor is accessible during operation, please attach the following warning label so that it is clearly visible.
- Always turn off the power to the motor before conducting checks or performing work on the motor.  
Thermally protected motors will restart automatically when motor temperature falls below a certain level.



Warning label

## 2. Checking the package contents

### 2.1 Checking the contents

Make sure that you have received all of the items listed below. If an accessory is missing or damaged, contact the nearest ORIENTAL MOTOR office.

- Motor ..... 1
- Capacitor ..... 1
- Capacitor cap ..... 1
- Varistor (surge absorber) ..... 2
- This operating manual ..... 1

### 2.2 Checking the product name and motor-capacitor combination

When the product first arrives, check the name plates to confirm that you have received the correct motor and capacitor combination. Make sure the motor's model name, voltage, output and capacitor capacitance, which are listed on the nameplate.

Model	Motor Model ※	Capacitor Model
<b>CBI540-701WU</b>	5IK40GN-AW-CB1	CH90CFAUL
<b>CBI560-801WU</b>	5IK60GU-AW-CB1	CH180CFAUL
<b>CBI590-801WU</b>	5IK90GU-AW-CB1	CH200CFAUL2

The clutch and brake unit is not sold separately from the motor.

※ Motors are recognized by UL. The clutch and brake unit is not UL recognized.  
 Recognized name and certified name are motor model name.

- **Standards** UL1004-1, UL1004-3, CSA C22.2 No.100, CSA C22.2 No.77  
 Standards File No. Motor : UL File No. E64197  
 Capacitor : UL File No. E83671(CYWT2) Capacitor cap : UL File No. E56078(YDTU2)
- **Applications for standard** EN60034-1, EN60034-5, EN60664-1, EN60950-1 or EN62368-1  
 Temperature rise tests required by the standards has been conducted with a gearhead.
- **Installation Conditions** Overvoltage category II , Pollution degree 2, Class I equipment (For EN standards)  
 When the machinery to which the motor is mounted requires overvoltage category III and pollution degree 3 specifications, install the motor in a cabinet that comply with IP54 and connect to power supply via an isolation transformer.

### 3. Installation

#### Installation conditions

Install the motor and capacitor in a location that meets the following conditions.

Using the motor and capacitor in a location that does not satisfy these conditions could damage it.

- Indoors (this product is designed and manufactured to be installed within another device)
- Ambient temperature :  $-10^{\circ}\text{C}(+14^{\circ}\text{F}) \sim +50^{\circ}\text{C}(+122^{\circ}\text{F})$  (avoid freezing)
- Ambient humidity : 85% max. (avoid condensation)
- Not exposed to explosive, flammable, or corrosive gas
- Not exposed to direct sunlight
- Not exposed to dust
- Not exposed to water or oil
- A place where heat can escape easily
- Not exposed to continuous vibration or excessive impact
- 1,000 meters or less above sea level
- Overvoltage category II , Pollution degree 2, Class I equipment (For EN standards)  
 When the machinery to which the motor is mounted requires overvoltage category III and pollution degree 3 specifications, install the motor in a cabinet that comply with IP54 and connect to power supply via an isolation transformer.

#### 3.1 Install the motor

##### 1) Fixing to the Equipment

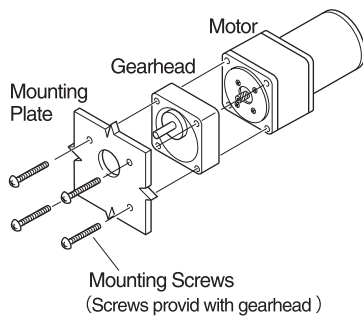

Drill holes in the mounting plate and fasten the gearhead (sold separately) and the motor to the mounting plate using the four screws provided with the gearhead. Install the equipment so that no gaps are left between the motor flange surface and the gearhead pilot section end surface.

Refer to the gearhead operation manual for further details concerning mounting. (gearhead sold separately)

Note : Use the gearhead of **GC** type or **GCH** type.  
 These gearheads are specially designed for **C•B** motors.

##### 2) Motor with cooling fan

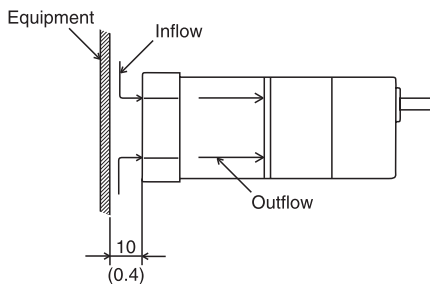

When installing a motor with a cooling fan onto a device, leave 10mm (0.4inch) or more behind the fan cover or open a ventilation hole so that the cooling inlet on the back of the motor cover is not blocked.

※ Dimensions in millimeters (inches).

#### 3.2 Mounting the capacitor

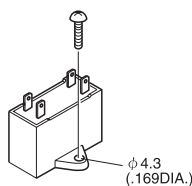

Before mounting the provided capacitor, check that the capacitor's capacitance matches that stated on the motor's name plate.

Use M4 screws to mount the capacitor (screws not provided).

※ Dimensions in millimeters (inches).

- Notes
- Do not let the screw fastening torque exceed 1N·m (8.8lb·in) to prevent damage to the mounting feet.
  - Mount capacitor at least 10cm (3.94inches) away from the motor. If it is located closer, the life of the capacitor will be shortened.

## 4. Connection and Operation

- Connect the motor according to the “wiring diagram” shown below.
- When using **C•B** motors, a DC24V power supply (0.5A min.) for the clutch and brake is required in addition to the motor power supply.
- Insulate all the wire connections, such as the connection between the motor and the capacitor connection.  
Capacitor caps are available to insulate capacitor connection.

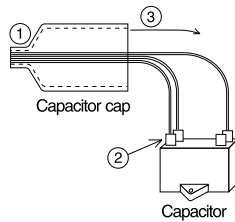

### Capacitor caps

- ① Pass the lead wires through the capacitor cap as shown in the figure.
- ② Connect the lead wires to the terminals or use terminal ends.
- ③ Cover the capacitor with the capacitor cap.

### ■ Connection diagram

#### 1) Connection diagram of clutch and brake

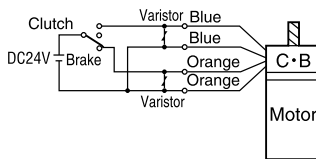

- Clutch and brake coil lead wires have no polarity.
  - The varistor (surge absorber) should be connected.
- Varistors are provided with **C•B** motor.

#### Varistor Specifications:

- Continuous rating voltage DC100V
- Continuous rating power 0.6W

#### 2) Wiring diagram

The direction of rotation is as viewed from the side of the motor's output shaft. “CW” indicates clockwise and “CCW” counterclockwise.

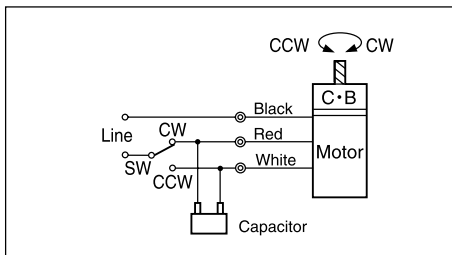

### Direction of Rotation

- To rotate the motor in a clockwise (CW) direction, switch SW to CW.
- To rotate it in a counter-clockwise (CCW) direction, switch SW to CCW.

#### 3) Operation

When the switch is flipped to Clutch while the motor is running, the output shaft runs and provides torque.

When the switch is flipped to Brake, the output shaft stops immediately and has holding torque.

When the switch is Neutral, the output shaft is able to be turned freely.

- Notes
- Make sure that the motor case temperature does not exceed 90°C (194°F) during motor operation. Operating the motor above 90°C (194°F) will shorten the life of the coil and the ball bearings. Motor case temperature can be measured by fastening a thermometer to the motor's surface, or with thermo-tape.
  - Bring motors to a complete stop before switching the direction of rotation. If you try to switch the direction of rotation before the motor has stopped, it may not change or may require time.
  - Use the provided capacitor and always keep the capacitor connected after the motor is started.
  - Do not try to activate clutch and brake simultaneously.
  - When shifting from clutch to brake or vice versa, leave a time lag of at least 20msec.

### ■ Capacitor Connection

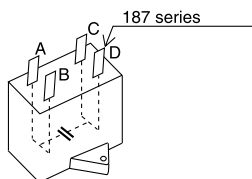

The capacitor internal wiring is as follows :

Capacitor terminals are internally electrically connected in twos ; A-B and C-D for easy connection.

For easy to install terminals use 187 series FASTON Terminals(TE Connectivity).  
For lead wire connection, use one lead wire for each individual terminal.

## 5. Time Rating

This motor can be operated continuously with a gearhead (continuous rating).

Run/Stop repetition rate max. 100times/min (Clutch and Brake).

## 6. Locked rotor burnout protection

This motor is equipped with a feature listed below to prevent the motor from burning out as a result of abnormal heating which may be caused by misapplication.

### ■ Thermal protection ( "TP" is stamped on the motor name plate)

When the motor reaches a predetermined temperature, the internal thermal protector is activated and the motor is stopped.

With the automatic resume feature, the motor automatically begins operating again as soon as the motor temperature falls.

Always turn the power off before performing inspections.

**Thermal protector activation range** : Power is turned off at  $130^{\circ}\text{C} \pm 5^{\circ}\text{C}$  ( $266^{\circ}\text{F} \pm 9^{\circ}\text{F}$ )

Power is turned back on at  $85^{\circ}\text{C} \pm 20^{\circ}\text{C}$  ( $185^{\circ}\text{F} \pm 36^{\circ}\text{F}$ )

## 7. Troubleshooting

When the motor is not functioning normally, perform an inspection covering the points listed in the table below.

If the inspection shows that everything is normal but the motor still is not functioning correctly, contact the nearest ORIENTAL MOTOR office.

Do not repair, disassemble or remodel it yourself.

Problem	Things to check
The motor does not rotate or motor rotates at low speed	<ol style="list-style-type: none"> <li>① Is the correct voltage being supplied to the motor?</li> <li>② Are lead wires properly and firmly connected?</li> <li>③ Is the load too large?</li> <li>④ If lead wires have been extended by using a terminal strip or terminal block, are the lead wires properly and firmly connected at all points?</li> <li>⑤ Is the provided capacitor connected as shown in the wiring diagram of page 3?</li> </ol>
The motor rotate correctly or properly	<ol style="list-style-type: none"> <li>① Are lead wires properly and firmly connected?</li> <li>② If lead wires have been extended by using a terminal strip or terminal block, are the lead wires properly and firmly connected at all points?</li> <li>③ Is the provided capacitor connected as shown in the wiring diagram of page 3?</li> </ol>
The motor rotates in the wrong direction	<ol style="list-style-type: none"> <li>① Is the connection as shown in the wiring diagram? Check the wiring diagram of page 3 again.</li> <li>② The gearhead output shaft's rotation direction differs depending on the gearhead's deceleration ratio. Refer to the operating manual of gearhead.</li> <li>③ Is the provided capacitor connected as shown in the wiring diagram of page 3?</li> <li>④ Are you looking at the motor from the wrong side? Rotation is defined as viewed from the output shaft side.</li> </ol>
The motor becomes extraordinarily hot (motor case temperature exceeds $90^{\circ}\text{C}$ ( $194^{\circ}\text{F}$ ))	<ol style="list-style-type: none"> <li>① Is the correct voltage being supplied to the motor?</li> <li>② Does the ambient temperature exceed the permissible range?</li> <li>③ Is the provided capacitor connected as shown in the wiring diagram of page 3?</li> </ol>
The motor makes a strange noise	<ol style="list-style-type: none"> <li>① Are the motor and gearhead correctly fastened? Refer to the operating manual of gearhead.</li> <li>② Is the coupled gearhead the same pinion type as the motor shaft?</li> </ol>
Clutch and Brake unit does not operate	<ol style="list-style-type: none"> <li>① Is the correct voltage being supplied to the clutch and brake unit?</li> <li>② Are lead wires properly and firmly connected?</li> <li>③ Is the connection as shown in the wiring diagram? Check the wiring diagram of page 3 again.</li> <li>④ If lead wires have been extended by using a terminal strip or terminal block, are the lead wires properly and firmly connected at all points?</li> </ol>

• Characteristics, specifications and dimensions are subject to change without notice.

• **Orientalmotor** is a trademark of Oriental Motor Co., Ltd.

Published in April 2020

• Please contact your nearest Oriental Motor office for further information.

ORIENTAL MOTOR U.S.A. CORP.  
Technical Support Tel:(800)468-3982  
www.orientalmotor.com

ORIENTAL MOTOR DO BRASIL LTDA.  
Tel:+55-11-3266-6018  
www.orientalmotor.com.br

ORIENTAL MOTOR (EUROPA) GmbH  
Schiebsstraße 44, 40549 Düsseldorf, Germany  
Technical Support Tel:00 800/22 55 66 22  
www.orientalmotor.de

ORIENTAL MOTOR (UK) LTD.  
Tel:01256-347090 www.oriental-motor.co.uk

ORIENTAL MOTOR (FRANCE) SARL  
Tel:01 47 86 97 50 www.orientalmotor.fr

ORIENTAL MOTOR ITALIA s.r.l.  
Tel:02-93906346 www.orientalmotor.it

ORIENTAL MOTOR ASIA PACIFIC PTE. LTD.  
Singapore  
Tel:1800-8420280  
www.orientalmotor.com.sg

ORIENTAL MOTOR (MALAYSIA) SDN. BHD.  
Tel:1800-806161  
www.orientalmotor.com.my

ORIENTAL MOTOR (THAILAND) CO., LTD.  
Tel:1800-888-881  
www.orientalmotor.co.th

ORIENTAL MOTOR (INDIA) PVT. LTD.  
Tel:+91-80-41125586  
www.orientalmotor.co.in

TAIWAN ORIENTAL MOTOR CO., LTD.  
Tel:0800-060708  
www.orientalmotor.com.tw

SHANGHAI ORIENTAL MOTOR CO., LTD.  
Tel:400-820-6516  
www.orientalmotor.com.cn

INA ORIENTAL MOTOR CO., LTD.  
Korea  
Tel:080-777-2042  
www.inaom.co.kr

ORIENTAL MOTOR CO., LTD.  
Hong Kong Branch  
Tel:+852-2427-9800

ORIENTAL MOTOR CO., LTD.  
4-8-1 Higashiueno, Taito-ku, Tokyo  
110-8536 Japan  
Tel:03-6744-0361  
www.orientalmotor.co.jp