

## OPERATING MANUAL

### AC Standard Motors Conduit Box Type Induction Motor

Thank you for purchasing an Oriental Motor product.

This Operating Manual describes product handling procedures and safety precautions.

- Please read it thoroughly to ensure safe operation.
- Always keep the manual where it is readily available.

## Introduction

### ■ Before use

Only qualified personnel should work with the product.

Use the product correctly after thoroughly reading the section “Safety precautions”.

Should you require the inspection or repair of internal parts, contact the Oriental Motor office where you purchased the product.

The product described in this manual has been designed and manufactured for use as an internal component for general industrial equipment, and must not be used for any other purpose. Oriental Motor Co., Ltd. is not responsible for any damage caused through failure to observe this warning.

### ■ UL Standards, CSA Standards

This product is recognized by UL under the UL and CSA Standards. Thermal class: 130 (B)

### ■ CE Marking

This product is affixed with the marks under the following directives.

### ● RoHS Directive

This product does not contain the substances exceeding the restriction values.

\* **5IK60GU-FCH, 5IK60GU-ECH, 5IK60GU-SH, 5IK90GU-FCH, 5IK90GU-ECH and 5IK90GU-SH** do not comply with the hazardous substances.

### ■ Motor temperature rise tests

A Running Heating Test and a Locked-Rotor Test has been conducted with a aluminum radiation plate of size indicated below. For the motor with a gearhead, tests has been conducted with a gearhead instead of the radiation plate.

First number in motor name	Size [mm (in.)]	Thickness [mm (in.)]	Material
4	135 × 135 (5.31 × 5.31)	5 (0.20)	Aluminium
5 (40 W)	165 × 165 (6.50 × 6.50)		
5 (60 W, 90 W)	200 × 200 (7.87 × 7.87)		

#### Installation conditions

Overvoltage category II, Pollution degree 3 (except for the motor mounting surface and conduit opening), Class I equipment (For EN standards)

When the machinery to which the motor is mounted requires overvoltage category III specifications, connect to power supply via an isolation transformer.

## Safety precautions

The precautions described below are intended to prevent danger or injury to the user and other personnel through safe, correct use of the product. Use the product only after carefully reading and fully understanding these instructions.

**⚠ WARNING** Handling the product without observing the instructions that accompany a “Warning” symbol may result in serious injury or death.

**⚠ CAUTION** Handling the product without observing the instructions that accompany a “Caution” symbol may result in injury or property damage.

**Note** The items under this heading contain important handling instructions that the user should observe to ensure safe use of the product.

### ⚠ WARNING

- Do not use the product in explosive or corrosive environments, in the presence of flammable gases, locations subjected to splashing water, or near combustibles. Doing so may result in fire, electric shock or injury.
- Assign qualified personnel the task of installing, wiring, operating/controlling, inspecting and troubleshooting the product. Failure to do so may result in fire, electric shock or injury.
- Do not transport, install the product, perform connections or inspections when the power is on. Always turn the power off before carrying out these operations. Failure to do so may result in electric shock.
- Turn off the power in the event the overheat protection device (thermal protector) is triggered. Failure to do so may result in injury or damage to equipment, since the motor will start abruptly when the overheat protection device (thermal protector) is automatically reset.
- The motor is class I equipment. Install the motor so as to avoid contact with hands, or ground it to prevent the risk of electric shock.
- Install the motor in an enclosure in order to prevent electric shock or injury.
- Keep the input power voltage within the specification to avoid fire and electric shock.
- Connect the cables securely according to the wiring diagram in order to prevent fire and electric shock.
- Do not forcibly bend, pull or pinch the lead wires. Doing so may result in fire and electric shock.
- Turn off the power in the event of a power failure, or the motor will suddenly start when the power is restored and may cause injury or damage to equipment.
- Do not touch the connection terminal of the capacitor immediately after the power is turned off (for a period of 30 seconds). The residual voltage may cause electric shock.
- Do not disassemble or modify the motor. This may cause electric shock or injury.

## ⚠ CAUTION

- Do not use the motor beyond its specifications, or electric shock, injury or damage to equipment may result.
- Do not touch the motor during operation or immediately after stopping. The surface is hot and may cause a burn.
- Do not hold the motor output shaft or motor lead wires. This may cause injury.
- Keep the area around the motor free of combustible materials in order to prevent fire or a burn.
- To prevent the risk of damage to equipment, leave nothing around the motor that would obstruct ventilation.
- To prevent bodily injury, do not touch the rotating parts (output shaft, cooling fan) of the motor during operation.
- When an abnormality is noted, turn off the power immediately, or fire, electric shock or injury may occur.
- The motor's surface temperature may exceed 70 °C, even under normal operating conditions. If a motor is accessible during operation, post the warning label shown in the figure in a conspicuous position to prevent the risk of skin burn(s).
- Dispose the product correctly in accordance with laws and regulations, or instructions of local governments.



Warning label

## Preparation

### ■ Checking the product

Verify that the items listed below are included. Report any missing or damaged items to the branch or sales office from which you purchased the product.

- Motor ..... 1 unit
- Instructions and Precautions for Safe Use ..... 1 copy

### ■ Checking the model name

Check the model number against the number indicated on the product.

Model	Model	Model
4IK25GN-FCH	4IK25GN-ECH	4IK25GN-SH
4IK25AA-FCH	4IK25AA-ECH	4IK25AA-SH
5IK40GN-FCH	5IK40GN-ECH	5IK40GN-SH
5IK40AA-FCH	5IK40AA-ECH	5IK40AA-SH
5IK60GE-FCH	5IK60GE-ECH	5IK60GE-SH
5IK60A-FCH	5IK60A-ECH	5IK60A-SH
5IK60GU-FCH	5IK60GU-ECH	5IK60GU-SH
5IK90GE-FCH	5IK90GE-ECH	5IK90GE-SH
5IK90A-FCH	5IK90A-ECH	5IK90A-SH
5IK90GU-FCH	5IK90GU-ECH	5IK90GU-SH

## Installation

### ■ Location for installation

The motor is designed and manufactured for installation in equipment.

Install it in a well-ventilated location that provides easy access for inspection. The location must also satisfy the following conditions:

- Inside an enclosure that is installed indoors (provide vent holes)
- Operating ambient temperature
  - 10 to +40 °C (+14 to +104 °F) (non-freezing)
  - 10 to +50 °C (+14 to +122 °F) for three-phase 200 V
- Operating ambient humidity 85%, maximum (non-condensing)
- Area that is free from an explosive atmosphere or toxic gas (such as sulfuric gas) or liquid
- Area not exposed to direct sun
- Area free of excessive amount dust, iron particles or the like
- Area not subject to splashing water (storms, water droplets), oil (oil droplets) or other liquids
- Area free of excessive salt
- Area not subject to continuous vibration or excessive shocks
- Area free of excessive electromagnetic noise (from welders, power machinery, etc.)
- Area free of radioactive materials, magnetic fields or vacuum
- 1000 m (3300 ft.) or less above sea level

### ■ How to install the motor

#### • Round shaft type

Drill holes on the mounting plate and fix the motor on the plate using screws, nuts, and washers (not supplied). Be careful there is no gap between the motor installation surface and the bracket.

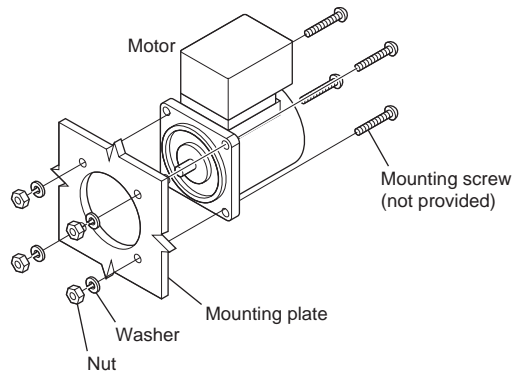

First number in motor model	Screw size	Tightening torque [N-m (lb-in)]
4	M5	2.5 (22)
5	M6	3.0 (26)

**Note** Do not insert the motor into the mounting hole at an angle or force it in, as this may scratch the flange pilot section and damage the motor.

### • Pinion shaft type

Drill holes on the mounting plate and fix the motor and gearhead on the plate using screws supplied with the gearhead. Be careful there is no gap between the motor flange and the gearhead. For details of installation, see the operating manual provided with the gearhead, which is sold separately.

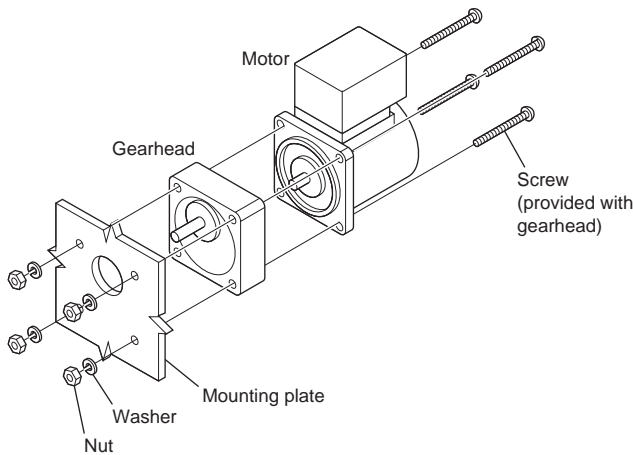

**Note** Use the gearhead with pinion shaft which is identical with one of motor.

### • Motor with cooling fan

When installing a motor with cooling fan onto a device, leave 10 mm (0.39 in.) or more behind the fan cover or open a ventilation hole so that the cooling inlet on the back of the motor cover is not blocked.

## Connection and operation

Insulate all the wire connections, such as the connection between the motor and the capacitor connection.

When the single-phase motor is run in only one direction, unused lead wires should be insulated.

Ground the motor using a Protective Earth lead wire (green/yellow). The direction of motor rotation is as viewed from the side of the motor's output shaft. The motor rotates in a clockwise (CW) and counterclockwise (CCW) direction.

- Note**
- Make sure that the motor case temperature does not exceed 90 °C (194 °F) during operation of the motor. Operation exceeding case temperature 90 °C (194 °F) may significantly deteriorate the coils and ball bearings of the motor and shorten the motor's life span. Motor case temperature can be measured by fixing a thermometer on the motor surface. It can also be measured using thermo tape or a thermocouple. Thermal Class: 130 (B)
  - To change rotation direction of the single-phase motor, wait until the motor completely stops. Otherwise its direction may not change or may take much time to change.

### ■ Rotating direction of the gearhead output shaft

The rotating direction of the gearhead output shaft may be opposite that of the motor shaft, depending on the gear ratio. For the rotating direction of the output shaft of a specific gearhead used, refer to the operating manual for the gearhead.

### ■ Connection method to a terminal box

- Open the terminal box and connect wires.
- Use applicable cable ground and conduit for conduit opening.
- After connecting, close the terminal box with the terminal cover.
- Terminal cover screws tightening torque  
Single-phase 25 W, 40 W/Three-phase: 0.3 N·m (2.6 lb-in)  
Single-phase 60 W, 90 W: 1 N·m (8.8 lb-in)

#### • Single-phase 25 W, 40 W/Three-phase

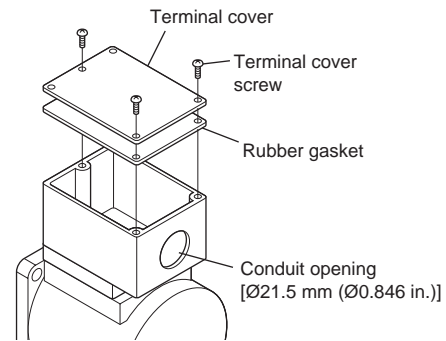

#### • Single-phase 60 W, 90 W

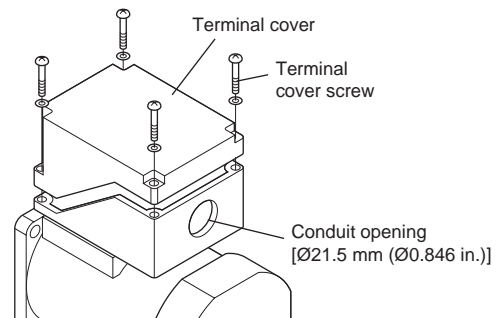

### ■ Single-phase motors

#### • Wiring diagram

Connect the motor according to the figure.

The connection method will vary, depending on the direction

Clockwise

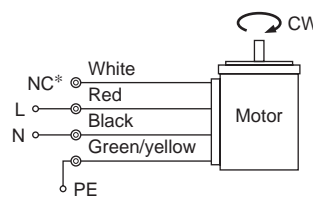

Counterclockwise

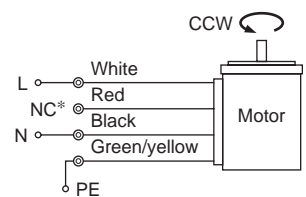

\* NC: Not connect.

### ■ Three-phase motors

Connect the motor according to the figure.

When connected according to the connection diagram, the motor will operate in the clockwise direction (CW) as viewed from the motor's output shaft. To change the direction of rotation, change any two connections between U, V and W.

Clockwise

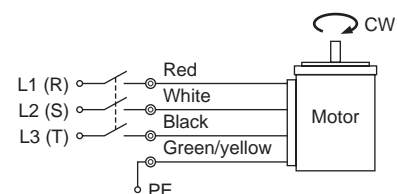

## Time rating

Motors have a continuous rating.

## Locked rotor burnout protection

This motor is equipped with the feature listed below to prevent the motor from burning out as a result of abnormal heating which may be caused by misapplication.

### • Thermal protection

“TP” is stamped on the motor nameplate. The motor has an “auto reset” type thermal protector built into its motor coil. When the motor reaches a predetermined temperature, the internal thermal protector is activated and the motor is stopped.

Always turn the power off before performing inspections.

### Thermal protector activation range

Power is turned off at  $130\pm 5$  °C ( $266\pm 9$  °F)

Power is turned back on at  $82\pm 15$  °C ( $180\pm 27$  °F)

## Troubleshooting

When the motor cannot be operated correctly, refer to the contents provided in this section and take appropriate action. If the problem persists, contact your nearest office.

Phenomena	Check items
Motor does not rotate or rotates slowly.	<ul style="list-style-type: none"> <li>• Check the power supply voltage.</li> <li>• Connect the power supply and the motor correctly.</li> <li>• If terminal blocks or crimp terminals are used, check them for poor connection.</li> <li>• Keep the load at or below the allowable value.</li> </ul>
Motor sometimes rotates and stops.	<ul style="list-style-type: none"> <li>• Connect the power supply and the motor correctly.</li> <li>• If terminal blocks or crimp terminals are used, check them for poor connection.</li> </ul>
The motor rotates in the direction opposite to the specified direction.	<ul style="list-style-type: none"> <li>• Connect correctly by referring to “Wiring diagram.”</li> <li>• The rotating direction of the motor output shaft may be different from that of the gearhead output shaft depending on the gear ratio of the gearhead. See the operating manual for the gearhead.</li> <li>• The rotating direction is indicated as viewed from the motor output shaft. Check the reference direction.</li> </ul>
Motor temperature abnormally high [Motor case temperature exceeds 90 °C (194 °F)]	<ul style="list-style-type: none"> <li>• Check the power supply voltage.</li> <li>• Review the ventilation condition.</li> </ul>
Noisy operation	<ul style="list-style-type: none"> <li>• Assemble the motor and gearhead correctly by referring to the operating manual for the gearhead.</li> <li>• Assemble a gearhead of the same pinion type as the motor.</li> </ul>

- Unauthorized reproduction or copying of all or part of this manual is prohibited.
- Oriental Motor shall not be liable whatsoever for any problems relating to industrial property rights arising from use of any information, circuit, equipment or device provided or referenced in this manual.
- Characteristics, specifications and dimensions are subject to change without notice.
- While we make every effort to offer accurate information in the manual, we welcome your input. Should you find unclear descriptions, errors or omissions, please contact the nearest office.
- **Orientalmotor** is a registered trademark or trademark of Oriental Motor Co., Ltd., in Japan and other countries.

© Copyright ORIENTAL MOTOR CO., LTD. 2008

Published in April 2026

• Please contact your nearest Oriental Motor office for further information.

ORIENTAL MOTOR U.S.A. CORP.  
Technical Support Tel:800-468-3982  
8:30am EST to 5:00pm PST (M-F)

ORIENTAL MOTOR (EUROPA) GmbH  
Schiebsstraße 44, 40549 Düsseldorf, Germany  
Technical Support Tel:00 800/22 55 66 22

ORIENTAL MOTOR (UK) LTD.  
Blythe Valley Business Park,  
Central Blvd Blythe Valley Park,  
Solihull B90 8AG, United Kingdom  
Tel:+44-1926-671220

ORIENTAL MOTOR (FRANCE) SARL  
Tel:+33-1 47 86 97 50

ORIENTAL MOTOR ITALIA s.r.l.  
Tel:+39-02-93906347

ORIENTAL MOTOR CO., LTD.  
4-8-1Higashiueno,Taito-ku,Tokyo 110-8536  
Japan  
Tel:+81-3-6744-0361  
www.orientalmotor.co.jp/ja

ORIENTAL MOTOR ASIA PACIFIC PTE. LTD.  
Singapore  
Tel:1800-842-0280

ORIENTAL MOTOR (MALAYSIA) SDN. BHD.  
Tel:1800-806-161

ORIENTAL MOTOR (THAILAND) CO., LTD.  
Tel:1800-888-881

ORIENTAL MOTOR (INDIA) PVT. LTD.  
Tel:1800-120-1995 (For English)  
1800-121-4149 (For Hindi)

TAIWAN ORIENTAL MOTOR CO., LTD.  
Tel:0800-060708

SHANGHAI ORIENTAL MOTOR CO., LTD.  
Tel:400-820-6516

INA ORIENTAL MOTOR CO., LTD.  
Korea  
Tel:080-777-2042