



OPERATING MANUAL

K II Series

Induction Motor

Single-phase 110/115 V, 220/230 V type

Introduction

■ Before using the motor

Only qualified personnel should work with the product. Use the product correctly after thoroughly reading the section "Safety precautions". Should you require the inspection or repair of internal parts, contact the Oriental Motor office where you purchased the product.

The product described in this manual has been designed and manufactured for use as a component to be installed in general industrial equipment, and must not be used for any other purpose. Oriental Motor Co., Ltd. is not responsible for any damage caused through failure to observe this warning.

■ Standard and CE Marking

Motors are recognized by UL.
Voluntary display of the CE Mark conforming to the Low Voltage Directives.
Refer to p.4 for details.

■ Hazardous substances

The products do not contain the substances exceeding the restriction values of RoHS Directive (2011/65/EU).

Safety precautions

The precautions described below are intended to prevent danger or injury to the user and other personnel through safe, correct use of the product. Use the product only after carefully reading and fully understanding these instructions.



Handling the product without observing the instructions that accompany a "Warning" symbol may result in serious injury or death.

- Do not use the product in explosive or corrosive environments, in the presence of flammable gases, or near combustibles. Doing so may result in fire, electric shock or injury.
- Assign qualified personnel the task of installing, wiring, operating/controlling, inspecting and troubleshooting the product. Failure to do so may result in fire, electric shock or injury.
- Do not transport, install the product, perform connections or inspections when the power is on. Always turn the power off before carrying out these operations. Failure to do so may result in electric shock.
- Turn off the power in the event the overheat protection device (thermal protector) is triggered. Failure to do so may result in injury or damage to equipment, since the motor will start abruptly when the overheat protection device (thermal protector) is automatically reset.
- The motor is Class I equipment. Install the motor so as to avoid contact with hands, or ground it to prevent the risk of electric shock.
- Keep the input-power voltage within the specification to avoid fire and electric shock.
- Connect the cables securely according to the wiring diagram in order to prevent fire and electric shock.
- Do not forcibly bend, pull or pinch the lead wires. Doing so may result in fire and electric shock.
- Be sure to insulate the connection terminal of the capacitor. Failure to do so may result in electric shock.
- Turn off the power in the event of a power failure, or the motor will suddenly start when the power is restored and may cause injury or damage to equipment.
- Do not touch the connection terminal of the capacitor immediately after the power is turned off (for a period of 30 seconds). The residual voltage may cause electric shock.
- Do not disassemble or modify the motor. This may cause electric shock or injury.

Thank you for purchasing an Oriental Motor product.
This Operating Manual describes product handling procedures and safety precautions.

- Please read it thoroughly to ensure safe operation.
- Always keep the manual where it is readily available.



Handling the product without observing the instructions that accompany a "Caution" symbol may result in injury or property damage.

- Do not use the motor beyond its specifications, or electric shock, injury or damage to equipment may result.
- Do not touch the motor during operation or immediately after stopping. The surface is hot and may cause a skin burn(s).
- Do not hold the motor output shaft or motor lead wires. This may cause injury.
- Keep the area around the motor free of combustible materials in order to prevent fire or a skin burn(s).
- To prevent the risk of damage to equipment, leave nothing around the motor that would obstruct ventilation.
- To prevent bodily injury, do not touch the rotating parts (output shaft) of the motor during operation.
- When an abnormality is noted, turn off the power immediately, or fire, electric shock or injury may occur.
- The motor's surface temperature may exceed 70 °C (158 °F), even under normal operating conditions. If a motor is accessible during operation, post the warning label shown in the figure in a conspicuous position to prevent the risk of skin burn(s).
- To dispose of the motor, disassemble it into parts and components as much as possible and dispose of individual parts/components as industrial waste.



Warning label

Preparation

■ Checking the product

Verify that the items listed below are included. Report any missing or damaged items to the branch or sales office from which you purchased the product.

- Motor1 unit
The combination type comes with the motor and its dedicated gearhead pre-assembled.
- Capacitor1 piece
- Capacitor cap1 piece
- OPERATING MANUAL1 copy (this document)
- Set of mounting screw1 set (only for combination type)
Mounting screws, washers, spring washers 4 pieces each, parallel key 1 piece

■ Checking the model name

Check the model number against the number indicated on the product.
Enter the gear ratio in the box (□) within the model name of the combination type.

• Lead wire type

Model	Motor model	Gearhead model	Degree of protection
2IK6UA-□	2IK6GV-UA	2GV□B	IP20
2IK6UC-□	2IK6GV-UC		
3IK15UA-□	3IK15GV-UA	3GV□B	
3IK15UC-□	3IK15GV-UC		
4IK25UA-□	4IK25GV-UA	4GV□B	
4IK25UC-□	4IK25GV-UC		
5IK40UA-□	5IK40GV-UA	5GV□B	
5IK40UC-□	5IK40GV-UC		
5IK60UA-□	5IK60GVH-UA	5GVH□B	
5IK60UC-□	5IK60GVH-UC		
5IK90UA-□	5IK90GVR-UA	5GVR□B	
5IK90UC-□	5IK90GVR-UC		

• Terminal Box Type

Model	Motor model	Gearhead model	Degree of protection
4IK25UAT-□	4IK25GV-UAT	4GV□B	IP65
4IK25UCT-□	4IK25GV-UCT		
5IK40UAT-□	5IK40GV-UAT	5GV□B	
5IK40UCT-□	5IK40GV-UCT		
5IK60UAT-□	5IK60GVH-UAT	5GVH□B	IP54
5IK60UCT-□	5IK60GVH-UCT		
5IK90UAT-□	5IK90GVR-UAT	5GVR□B	
5IK90UCT-□	5IK90GVR-UCT		

Installation

■ Location for installation

Install it in a well-ventilated location that provides easy access for inspection.

[Common conditions]

- Operating ambient temperature -10 to +40 °C (+14 to +104 °F) (non-freezing)
- Operating ambient humidity 85%, maximum (non-condensing)
- Area that is free from an explosive atmosphere or toxic gas (such as sulfuric gas) or liquid
- Area not exposed to direct sun
- Area free of excessive amount dust, iron particles or the like
- Area free of excessive salt
- Area not subject to continuous vibration or excessive shocks
- Area free of excessive electromagnetic noise (from welders, power machinery, etc.)
- Area free of radioactive materials, magnetic fields or vacuum
- 1000 m (3300 ft.) or less above sea level

[Degree of protection IP65 rated motor]

- Indoors
- Not exposed to oil (oil droplets) or chemicals.
The motors can be used where they are splashed with water. Not available for use under high pressure jets of water or immersion in water.

[Degree of protection IP54/20 rated motor]

- Inside an enclosure that is installed indoors (provide vent holes)
- Area not subject to splashing water (storms, water droplets), oil (oil droplets) or other liquids

Note On rare occasions, a small amount of grease may ooze out from the gearhead. If there is a concern over possible environmental damage resulting from the leakage of grease, provide an oil tray or similar oil catching mechanism in order not to cause a secondary damage. Oil leakage may lead to problems in the customer's equipment or products.

■ How to install the motor

Drill holes on the mounting plate and fix the motor and gearhead on the plate using four screws (provided). If you are purchasing only a motor for maintenance purpose, a mounting screw set is included in the gearhead.

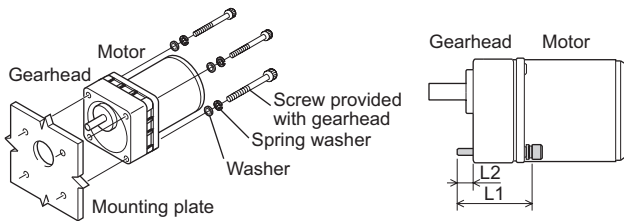

Set of mounting screws (provided)

Model	Gear ratio	Hexagonal Socket Head Screw			Tightening torque [N·m (lb-in)]
		Screw size	L1 [mm (in.)]	L2 [mm (in.)]	
2IK6	5 to 25	M4	50 (1.97)	7 (0.28)	1.8 (15)
	30 to 120		55 (2.17)	8 (0.31)	
	150 to 360		60 (2.36)	8 (0.31)	
3IK15	5 to 25	M6	60 (2.36)	12 (0.47)	6.4 (56)
	30 to 120		65 (2.56)	12 (0.47)	
	150 to 360		70 (2.76)	12 (0.47)	
4IK25	5 to 25	M6	60 (2.36)	9 (0.35)	6.4 (56)
	30 to 120		65 (2.56)	9 (0.35)	
	150 to 360		70 (2.76)	9 (0.35)	
5IK40 5IK60	5 to 18	M8	70 (2.76)	14 (0.55)	15.5 (137)
	25 to 100		85 (3.35)	16 (0.63)	
	120 to 300		90 (3.54)	15 (0.59)	
5IK90	5 to 15	M8	70 (2.76)	14 (0.55)	15.5 (137)
	18 to 36		85 (3.35)	16 (0.63)	
	50 to 180		95 (3.74)	14 (0.55)	

• Removing/Installing the gearhead

When replacing a gearhead, switching the direction of cable entry, or changing the position of the terminal box, install/remove the gearhead as shown below.

Removing a gearhead from a motor

Remove the gearhead by unscrewing the hexagonal socket-head screws holding the gearhead to the motor (2 locations).

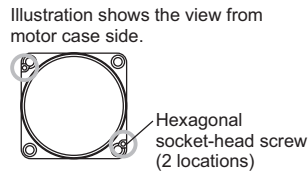

Gearhead model	Screw size
2GV□B	M2.6
3GV□B	
4GV□B	
5GV□B	M3
5GVH□B	
5GVR□B	

Installing a gearhead to a motor

Using the pilot sections of the motor and gearhead as guides, slowly rotate it clockwise/counterclockwise to prevent the pinion of the motor output shaft from contacting the side panel or gear of the gearhead.

Also confirm that no gaps remain between the motor and gearhead. An O-ring is attached to the flange of the motor. Do not pinch the O-ring when assembling the motor and gearhead. Pinching the O-ring causes a grease leak from the gearhead.

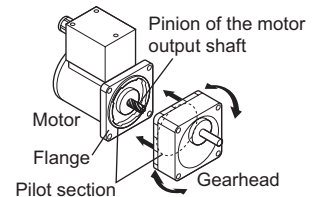

Note Do not forcibly assemble the motor and gearhead. Also, do not let metal objects or other foreign matters enter the gearhead. The pinion or gear of the motor output shaft may be damaged, resulting in noise or shorter service life.

■ Motor with cooling fan

When installing a motor with cooling fan onto a device, leave 10 mm (0.39 in.) or more behind the fan cover or open a ventilation hole so that the cooling inlet on the back of the motor cover is not blocked.

■ Mounting the capacitor

Mount the capacitor securely by using M4 screws (not provided).

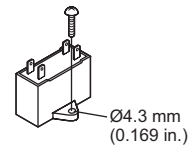

Note • Do not let the screw fastening torque exceed 1 N·m (8.8 lb-in) to prevent damage to the mounting foot.
• Mount capacitor at least 10 cm (3.94 in.) away from the motor. If it is located closer, the life of the capacitor will be shortened.

■ Attaching Load

The gearhead shaft is provided with a key slot for connecting the transmission parts. When connecting the transmission parts, ensure that the shaft and parts have a clearance fit, and always fix the parallel key to the output shaft with a screw to prevent the parts from rattling or spinning.

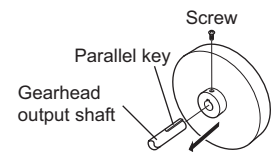

Note Do not use excessive force, or hammer the transmission parts onto the gearmotor shaft as damage may occur.

• When using the output axis tip screw hole of a gearhead

Use a screw hole provided at the tip of the output shaft as an auxiliary means for preventing the transfer mechanism from disengaging. (2GV□B, 3GV□B type have no output shaft tip screw hole.)

Gearhead model	Output shaft tip screw hole
4GV□B	M5
5GV□B	M6
5GVH□B	
5GVR□B	

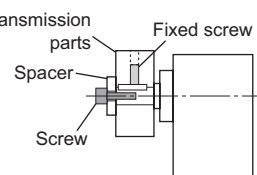

Connection and operation

- Insulate all the wire connections, such as the connection between the motor and the capacitor connection.
- Ground the motor using a Protective Earth Terminal.

Note

- Make sure that the motor case temperature does not exceed 90 °C (194 °F) during operation of the motor. Operation exceeding case temperature 90 °C (194 °F) may significantly deteriorate the coils and ball bearings of the motor and shorten the motor's life span. Motor case temperature can be measured by fixing a thermometer on the motor surface. It can also be measured using thermo tape or a thermocouple.
- To change rotation direction of the motor, wait until the motor completely stops. Otherwise its direction may not change or may take much time to change.

Wiring diagram

Check the output power and gear ratio of the motor before connecting.

Wiring diagram No.

Motor model	Gear ratio	Wiring diagram	Gear ratio	Wiring diagram
2IK6 3IK15 4IK25	5 to 25 150 to 360	Lead wire type: ①	30 to 120	Lead wire type: ②
5IK40 5IK60	5 to 18 120 to 300	Terminal box type: ③	25 to 100	Terminal box type: ④
5IK90	5 to 15 75 to 180		18 to 60	

Wiring diagram

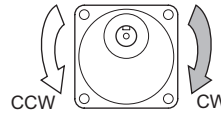
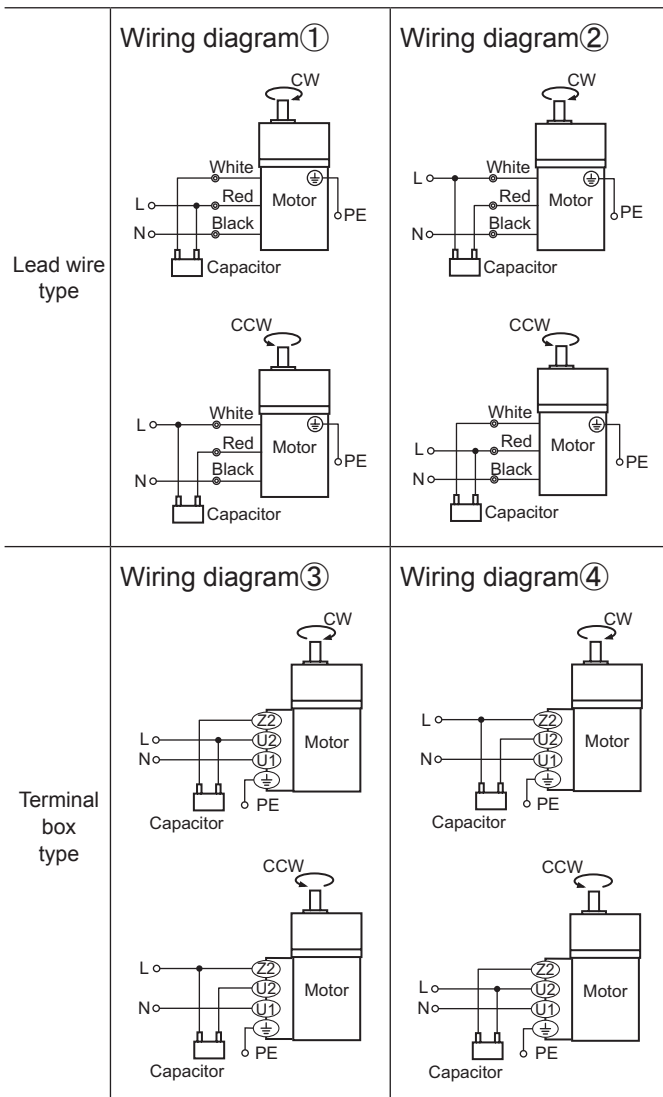

The rotation direction of motor is as viewed from the output shaft.

The direction of motor rotation is as viewed from the side of the motor's output shaft. The motor rotates in a clockwise (CW) and counterclockwise (CCW) direction. The rotating direction of the gearhead output shaft may be opposite that of the motor shaft, depending on the gear ratio.

Capacitor connection

The capacitor internal wiring as follows: Capacitor terminals are internally electrically connection in two; A-B and C-D for easy connection. For easy to install terminals use 187 series FASTON terminals (TE Connectivity). Use the supplied capacitor cap to insulate the capacitor terminal connection.

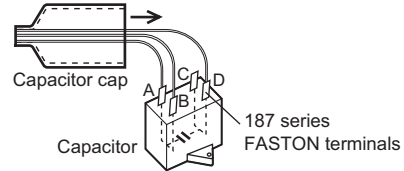

Note

For lead wire connection, use one lead wire for each individual terminal.

Lead wire type

Connecting Protective Earth Terminal

Be sure to ground the motor using the Protective Earth Terminal (⊕) on the motor.

Applicable crimp terminal:

Insulated round crimp terminal

Terminal screw size: M4

Tightening torque:

1.0 to 1.3 N·m (8.8 to 11.5 lb-in)

Applicable minimum lead wire size:

AWG18 (0.75mm² or more)

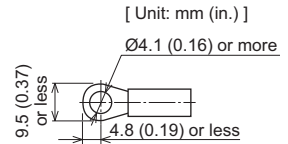

Note

Do not use screws other than the Protective Earth Terminal screws attached on the product.

Terminal box type

Connection method to a terminal box

Connect the motor to a terminal box by following the procedure below:

1. Loosen the terminal cover mounting screws (M4-3 pcs.) and remove the terminal cover and sheet gasket from the terminal box.
2. Pass the cable through the cable gland and connect the lead wires to the terminal block.
3. Install the sheet gasket and terminal cover on the terminal box.

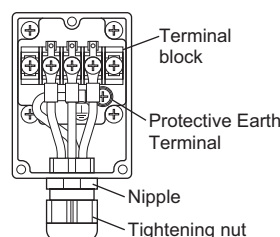
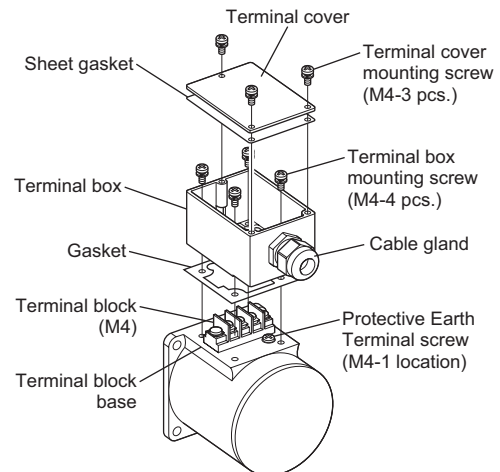

- Layout of terminals
Z2, U2 and U1 are indicated on the side face of the terminal block.

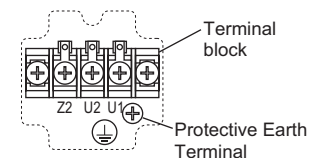

- When connecting the cable (not supplied), use the following terminal strip.
Round terminal with insulated coating
[Unit: mm (in.)]

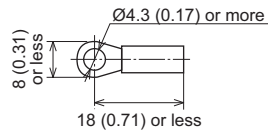

- To ensure safety, ground the motor using the Protective Earth Terminal (⊕) inside the terminal box.
- Use a cable of the following specifications:
Applicable cable diameter: Ø6 to 12 mm (Ø0.24 to 0.47 in.)
Applicable lead wire: AWG20 (0.5 mm²) or more
- Don't forget to assemble the sheet gasket between terminal box and terminal cover. When assembling the parts, also be careful not to let any foreign object enter between the terminal cover and terminal box.
- Refer to the table below to determine the appropriate tightening torque to use when fastening the terminal cover and cable gland.

Terminal cover	0.3 to 1.0 N·m (2.6 to 8.8 lb-in)
Terminal box	1.0 to 1.5 N·m (8.8 to 13.2 lb-in)
Cable gland (Tightening nut)	2.0 to 2.5 N·m (17.7 to 22 lb-in)
Cable gland (Nipple)	2.0 to 3.75 N·m (17.7 to 33 lb-in)
Protective Earth terminal	1.0 to 1.5 N·m (8.8 to 13.2 lb-in)
Terminal box	1.0 to 1.2 N·m (8.8 to 10.6 lb-in)

Note

- To make shielding function fully effective, use a cable of an appropriate diameter and tightening torque.
- Securely affix the cable exposed outside the motor so that it does not receive stress.

Changing the cable outlet position

The cable outlet can be oriented and fixed in three different directions by changing the mounting direction of the terminal box. Follow the procedure below:

- Loosen the terminal cover mounting screws (M4-3 pcs.) and remove the terminal cover and sheet gasket from the terminal box.
- Loosen the terminal box mounting screws (M4-4 pcs.) and remove the terminal box from the terminal block base.
- Turn the cable outlet on the terminal box clockwise or counterclockwise by 90° at a time from the factory-set position.
- Install the terminal box onto the terminal block base.
- Install the sheet gasket and terminal cover onto the terminal box.

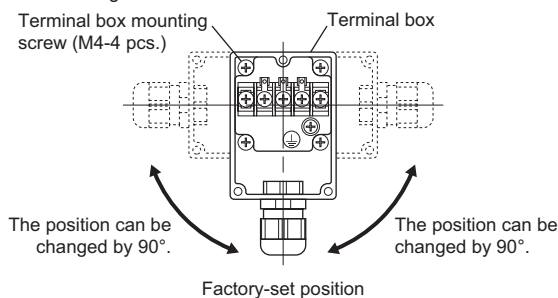

- A gasket is installed between the terminal box and terminal block base. Don't forget to assemble the gasket. When assembling the parts, also be careful not to let any foreign object enter between the terminal box and terminal block base.
- Refer to the aforementioned table for the screw tightening torque.

Time rating

The motor have a continuous rating.

Locked rotor burnout protection

This motor is equipped with one of the two features listed below to prevent the motor from burning out as a result of abnormal heating which may be caused by misapplication.

■ Thermal protection

"TP" is stamped on the motor nameplate. The motor has an "auto reset" type thermal protector built into its motor coil. When the motor reaches a predetermined temperature, the internal thermal protector is activated and the motor is stopped.

Always turn the power off before performing inspections.

Thermal protector activation range:

Power is turned off at 130±5 °C (266±9 °F)

Power is turned back on at 85±20 °C (185±36 °F)

■ Impedance protection

"ZP" is stamped on the motor nameplate. The motor has higher coil impedance. When the motor goes into locked rotor condition due to a malfunction, coil impedance rises, suppressing input power to the motor and protecting the motor coil from burnout.

Troubleshooting

When the motor cannot be operated correctly, refer to the contents provided in this section and take appropriate action. If the problem persists, contact your nearest office.

Phenomena	Check items
Motor does not rotate.	<ul style="list-style-type: none"> Check the power supply voltage. Connect the power supply and the motor correctly.
Motor sometimes rotates and stops.	<ul style="list-style-type: none"> Connect the supplied capacitor correctly. If terminal blocks or crimp terminals are used, check them for poor connection. Keep the load at or below the allowable value.
The motor rotates in the direction opposite to the specified direction.	<ul style="list-style-type: none"> Connect the supplied capacitor correctly. The rotating direction of the motor output shaft may be different from that of the gearhead output shaft depending on the gear ratio of the gearhead. The rotating direction is indicated as viewed from the motor output shaft. Check the reference direction.
Motor temperature abnormally high [Motor case temperature exceeds 90 °C (194 °F)]	<ul style="list-style-type: none"> Check the power supply voltage. With a single-phase motor, connect the supplied capacitor correctly. Review the ventilation condition.
Noisy operation	<ul style="list-style-type: none"> Assemble the motor and gearhead correctly. Assemble a gearhead of the same pinion type as the motor.

Standard and CE Marking

Motors are recognized by UL. Recognized name is motor model name. Voluntary display of the CE Mark conforming to the Low Voltage Directives.

• Standards

UL 1004-1, UL 1004-2, UL 1004-3, CSA C22.2 No.100, CSA C22.2 No.77

• Standards File No.

UL File No. E64197, E64199

• Applications for standard

EN 60034-1, EN 60034-5, EN 60664-1

Temperature rise tests required by the standards are performed in a state that has been attached a heat radiation plate instead of a gearhead. The size and material for the heat radiation plates are as follows.

2IK6: 115×115 mm (4.53×4.53 in.) **3IK15:** 125×125 mm (4.92×4.92 in.)

4IK25: 135×135 mm (5.31×5.31 in.) **5IK40:** 165×165 mm (6.50×6.50 in.)

5IK60, 5IK90: 200×200 mm (7.87×7.87 in.)

Thickness: 5 mm (0.20 in.) Material: Aluminium

• Thermal Class

130 (B)

• Installation conditions (For EN standard)

Lead wire type: Overvoltage category II, Pollution degree 2, Class I equipment

Terminal box type: Overvoltage category II, Pollution degree 3, Class I equipment

When the machinery to which the motor is mounted requires overvoltage category III specifications, install the motor in a cabinet that connect to power supply via an isolation transformer.

- Unauthorized reproduction or copying of all or part of this manual is prohibited.
- Characteristics, specifications and dimensions are subject to change without notice.
- Orientalmotor** is a registered trademark or trademark of Oriental Motor Co., Ltd., in Japan and other countries.

© Copyright ORIENTAL MOTOR CO., LTD. 2013

• Please contact your nearest Oriental Motor office for further information.

ORIENTAL MOTOR U.S.A. CORP.
Technical Support Tel:(800)468-3982
8:30 A.M. to 5:00 P.M., P.S.T. (M-F)
7:30 A.M. to 5:00 P.M., C.S.T. (M-F)
www.orientalmotor.com
ORIENTAL MOTOR DO BRASIL LTDA.
Tel:+55-11-3266-6018
www.orientalmotor.com.br
ORIENTAL MOTOR (EUROPA) GmbH
Schiessstraße 74, 40549 Düsseldorf, Germany
Technical Support Tel:00 800/22 55 66 22
www.orientalmotor.de
ORIENTAL MOTOR (UK) LTD.
Tel:01256-347090
www.oriental-motor.co.uk
ORIENTAL MOTOR (FRANCE) SARL
Tel:01 47 86 97 50
www.orientalmotor.fr
ORIENTAL MOTOR ITALIA s.r.l.
Tel:02-93906346
www.orientalmotor.it
ORIENTAL MOTOR CO., LTD.
4-8-1Higashiueno, Taito-ku, Tokyo 110-8536
Japan
Tel:03-6744-0361
www.orientalmotor.co.jp

ORIENTAL MOTOR ASIA PACIFIC PTE. LTD.
Singapore
Tel:1800-8420280
www.orientalmotor.com.sg
ORIENTAL MOTOR (MALAYSIA) SDN. BHD.
Tel:1800-806161
www.orientalmotor.com.my
ORIENTAL MOTOR (THAILAND) CO., LTD.
Tel:1800-888-881
www.orientalmotor.co.th
ORIENTAL MOTOR (INDIA) PVT. LTD.
Tel:+91-80-41125586
www.orientalmotor.co.in
TAIWAN ORIENTAL MOTOR CO., LTD.
Tel:0800-060708
www.orientalmotor.com.tw
SHANGHAI ORIENTAL MOTOR CO., LTD.
Tel:400-820-6516
www.orientalmotor.com.cn
INA ORIENTAL MOTOR CO., LTD.
Korea
Tel:080-777-2042
www.inaom.co.kr
ORIENTAL MOTOR CO., LTD.
Hong Kong Branch
Tel:+852-2427-9800