

AC Speed Control Motor

SCM Motor

OPERATING MANUAL

Thank you for purchasing an Oriental Motor product.

This Operating Manual describes product handling procedures and safety precautions.

- Please read it thoroughly to ensure safe operation.
- Always keep the manual where it is readily available.

Table of contents

1	Introduction	2
2	Safety precautions	3
3	Precautions for use	5
4	Preparation	6
4.1	Checking the product	6
4.2	Combination tables.....	6
4.3	Information about nameplate.....	7
5	Installation	8
5.1	Installation location.....	8
5.2	Installation method.....	9
5.3	Installing a load.....	11
5.4	Permissible radial load and permissible axial load.....	12
6	Grounding.....	13
7	Maintenance · inspection	14
7.1	Inspection	14
7.2	Warranty.....	14
7.3	Disposal	14
8	Specifications.....	15
8.1	Specifications	15
8.2	General specifications	15
8.3	Time rating	15
9	Regulations and standards.....	16

1 Introduction

■ Before using the motor

Only qualified personnel should work with the product. Use the product correctly after thoroughly reading the section "Safety precautions." In addition, be sure to observe the contents described in warning, caution, and note in this manual.

The product described in this manual has been designed and manufactured to be incorporated in general industrial equipment. Do not use for any other purpose.

Oriental Motor Co., Ltd. is not responsible for any damage caused through failure to observe this warning.

■ Related operating manuals

Operating manuals are not included with the product. Download from Oriental Motor Website Download Page or contact your nearest Oriental Motor sales office.

	Operating manual name
Motor	SCM Motor OPERATING MANUAL (this document)
Speed controller	DSC Series OPERATING MANUAL
	DSC Series For Electromagnetic Brake Motor OPERATING MANUAL
	US2 Series OPERATING MANUAL





Refer to the operating manuals of the speed controller for details about connections and operations.

Search for an operating manual by the model name shown on the nameplate.



2 Safety precautions



The precautions described below are intended to prevent danger or injury to the user and other personnel through safe, correct use of the product.





Please read and understand these precautions thoroughly before using the product.

 WARNING	Handling the product without observing the instructions that accompany a "WARNING" symbol may result in serious injury or death.
 CAUTION	Handling the product without observing the instructions that accompany a "CAUTION" symbol may result in injury or property damage.
 Note	The items under this heading contain important handling instructions that the user should observe to ensure safe use of the product.
 memo	The items under this heading contain related information and contents to gain a further understanding of the text in this manual.

Description of graphic symbols

	Indicates "prohibited" actions that must not be performed.
	Indicates "compulsory" actions that must be performed.

 WARNING	
	<ul style="list-style-type: none"> Do not use the product in explosive or corrosive environments, in the presence of flammable gases, in places subjected to splashing water, or near combustibles. Doing so may result in fire, electric shock or injury. Do not transport, install the product, perform connections or inspections when the power is on. Always turn the power off before carrying out these operations. Failure to do so may result in electric shock or equipment damage. Do not use the brake mechanism of the electromagnetic brake motor as a safety brake. Doing so may result in injury or damage to equipment. Do not machine or modify the cable. Doing so may result in fire, electric shock or damage to equipment. Do not forcibly bend, pull or pinch the cables. Doing so may result in fire, electric shock or damage to equipment. Do not touch the motor when conducting insulation resistance measurement or dielectric strength test. Accidental contact may result in electric shock. Do not disassemble or modify the motor. This may cause electric shock, injury or damage to equipment.
	<ul style="list-style-type: none"> Only qualified and educated personnel should be allowed to perform installation, connection, operation and inspection/troubleshooting of the product. Handling by unqualified and uneducated personnel may result in fire, electric shock, injury or equipment damage. Use an electromagnetic brake motor in an application of vertical drive such as elevating equipment. If a motor without an electromagnetic brake is used, the moving part may drop. This may result in injury or damage to equipment. The motor is Class I equipment. When installing the motor, ground the Protective Earth Terminal of the motor. Failure to do so may result in electric shock. Keep the input power voltage within the specified range. Failure to do so may result in fire or electric shock. Use a motor and speed controller only in the specified combination. An incorrect combination may cause in fire, electric shock or equipment damage. Always turn off the power before performing maintenance/inspection. Failure to do so may result in electric shock.

 CAUTION	
	<ul style="list-style-type: none"> • Do not use the motor beyond its specifications. Doing so may result in electric shock, injury or damage to equipment. • Do not touch the motor during operation or immediately after stopping. The surface is hot and may cause a skin burn(s). • Keep the area around the motor free of combustible materials. Failure to do so may result in fire or a skin burn(s). • Do not leave anything around the motor that would obstruct ventilation. Doing so may result in damage to equipment. • Do not lift up the product by holding the output shaft or the cable. Doing so may result in injury. • Do not touch the motor output shaft (tip or pinion) with bare hands. Doing so may result in injury. • When assembling the motor with the gearhead, exercise caution not to pinch your fingers or other parts of your body between the motor and gearhead. Injury may result. • When installing the motor in the equipment, exercise caution not to pinch your fingers or other parts of your body between the equipment and motor. Injury may result. • Do not touch the rotating part (output shaft) while operating the motor. Doing so may result in injury.
	<ul style="list-style-type: none"> • When an abnormality is noted, turn off the power immediately. Failure to do so may result in fire, electric shock or injury. • Securely install the motor to the mounting plate. Inappropriate installation may cause the motor to detach and fall, resulting in injury or equipment damage. • Provide a cover on the rotating part (output shaft). Failure to do so may result in injury. • Securely install the load on the output shaft. Inappropriate installation may result in injury. • Be sure to ground the motor to prevent it from being damaged by static electricity. Failure to do so may result in fire or damage to equipment. • The motor surface temperature may exceed 70 °C (158 °F) even under normal operating conditions. If the operator is allowed to approach a running motor, attach a warning label as shown in the figure in a conspicuous position. Failure to do so may result in skin burn(s). <div style="text-align: right; margin-top: 10px;">  Warning label </div>

3 Precautions for use

This section covers restrictions and requirements the user should consider when using the product.

- **Be sure to match the output power and power supply voltage when combining a motor and speed controller**

- **Connecting the motor and speed controller**

Use a connection cable (sold separately) when extending the wiring distance between the motor and the speed controller.

- **Use an electromagnetic brake motor in an application of vertical drive such as elevating equipment**

When the motor is used in an application of vertical drive such as elevating equipment (lifting and lowering device), use an electromagnetic brake motor so that the load can be held in position.

- **Caution when using under low temperature environment**

When an ambient temperature is low, since the load torque may increase by the viscosity increment of the oil seal or grease, the motor starting may take a long time or the motor rotation speed may fall. However, if the operation is continued for a while, the oil seal or grease will be warmed up, and the motor can be driven at the normal rotation speed.



- **Do not forcibly stop the shaft rotation of gearhead by an external force**

Stopping in such a way may cause impact, leading to damage to the gearhead.

- **Rotation direction of the output shaft**

The rotation direction of the gearhead output shaft with respect to the motor output shaft is shown in the figure below.

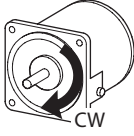
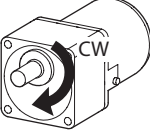
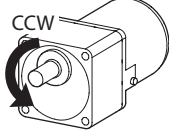
Motor output shaft (Including the round shaft type)	Gearhead output shaft		
	2GV□B 3GV□B 4GV□B	Gear ratio: 5 to 25 150 to 360	Gear ratio: 2, 3 30 to 120
5GV□B 5GVH□B	Gear ratio: 5 to 18 120 to 300	Gear ratio: 2, 3 25 to 100	
5GVR□B	Gear ratio: 5 to 15 75 to 180	Gear ratio: 2, 3 18 to 60	

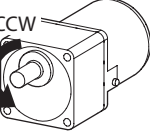
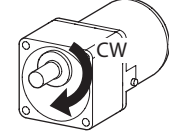
4 Preparation

4.1 Checking the product

Verify that the items listed below are included.

Report any missing or damaged items to the branch or sales office from which you purchased the product.

Verify the model number of the purchased product against the number shown on the nameplate.

■ Motor

- Motor..... 1 unit
- Instructions and Precautions for Safe Use..... 1 copy

■ Parallel shaft gearhead GV gearhead (sold separately)

- Gearhead..... 1 unit
- Mounting screw..... 1 set
Hexagonal socket head screw, plain washer, spring washer: 4 pieces each
Parallel key: 1 piece
- Screw for motor assembly 1 set
Hexagonal socket head screw: 2 pieces

4.2 Combination tables

- Enter the code representing the power supply voltage in the box ■ within the model name.
JA: Single-phase 100 V 50/60 Hz **JC:** Single-phase 200 V 50/60 Hz
UA: Single-phase 110/115 V 60 Hz **EC:** Single-phase 220/230 V 50/60 Hz
- Enter the number representing the gear ratio of the gearhead in the box □ within the model name.

	Output power	Model	Applicable gearhead		Applicable speed controller
			Model	Gear ratio (□)	
Pinion shaft type/ parallel shaft gearhead GV gearhead	6 W	SCM26GV-■	2GV□B	2 to 360	DSC Series US2 Series
	15 W	SCM315GV-■	3GV□B		
	25 W	SCM425GV-■	4GV□B		
	40 W	SCM540GV-■	5GV□B	2 to 300	
	60 W	SCM560GVH-■	5GVH□B		
	90 W	SCM590GVR-■	5GVR□B		
Electromagnetic brake type Pinion shaft type/ parallel shaft gearhead GV gearhead	6 W	SCM26GV-■M	2GV□B	7.5 to 360	DSC Series
	15 W	SCM315GV-■M	3GV□B		
	25 W	SCM425GV-■M	4GV□B		
	40 W	SCM540GV-■M	5GV□B	7.5 to 300	
	60 W	SCM560GVH-■M	5GVH□B		
	90 W	SCM590GVR-■M	5GVR□B		
Round shaft type	6 W	SCM26A-■	-	-	DSC Series US2 Series
	15 W	SCM315A-■			
	25 W	SCM425A-■			
	40 W	SCM540A-■			
	60 W	SCM560A-■			
	90 W	SCM590A-■			

4.3 Information about nameplate

The figure shows an example.



The position describing the information may vary depending on the product.

Motor

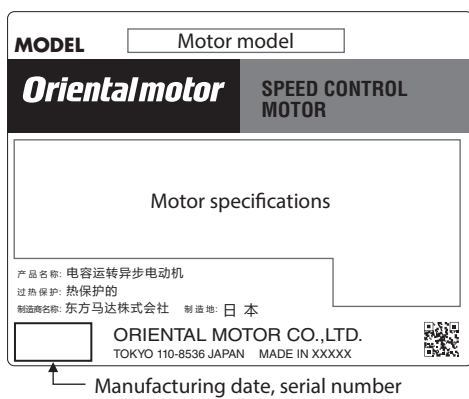

Gearhead



5 Installation

This section explains the installation method of a load in addition to the installation location and installation method of the product.

5.1 Installation location

Install the product in a well-ventilated location that provides easy access for inspection.

- Indoors
- Operating ambient temperature
Classification representing the power supply voltage **JA/JC**: -10* to +50 °C (+14 to +122 °F) (non-freezing)
UA/EC: -10* to +40 °C (+14 to +104 °F) (non-freezing)
- * The lowest temperature is 0 °C (+32 °F) for gearheads of the gear ratio 2 and 3.
- Operating ambient humidity 85% or less (non-condensing)
- Area that is free from an explosive atmosphere or toxic gas (such as sulfuric gas) or liquid
- Area not exposed to direct sun
- Area free of excessive amount dust, iron particles or the like
- Area not subject to splashing water (storms, water droplets), oil (oil droplets) or other liquids
- Area free of excessive salt
- Area not subject to continuous vibration or excessive shocks
- Area free of excessive electromagnetic noise (from welders, power machinery, etc.)
- Area free of radioactive materials, magnetic fields or vacuum
- Altitude Up to 1000 m (3300 ft.) above sea level

Note On rare occasions, grease may ooze out from the gearhead. If there is a concern over possible environmental damage resulting from the leakage of grease, provide an oil tray or similar oil catching mechanism in order not to cause a secondary damage. Grease leakage may lead to problems in the customer's equipment or products.

● **Installing to mounting plate**

Use the mounting screw included with a gearhead to secure the motor and gearhead to the mounting plate. Install so that there is no gap between the product and the mounting plate.

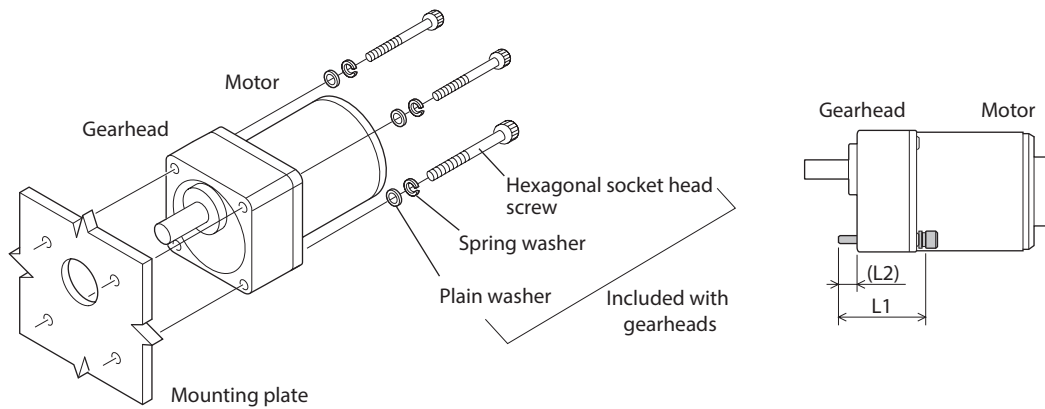

Mounting screw*

Gearhead model	Gear ratio	Hexagonal socket head screw		L2 [mm (in.)]	Tightening torque [N·m (lb-in)]
		Screw size	L1 [mm (in.)]		
2GV□B	2, 3, 30 to 120	M4	55 (2.17)	8 (0.31)	1.4 (12.3)
	5 to 25		50 (1.97)	7 (0.28)	
	150 to 360		60 (2.36)	8 (0.31)	
3GV□B	2, 3, 30 to 120	M6	65 (2.56)	12 (0.47)	5.0 (44)
	5 to 25		60 (2.36)	12 (0.47)	
	150 to 360		70 (2.76)	12 (0.47)	
4GV□B	2, 3, 30 to 120	M6	65 (2.56)	9 (0.35)	5.0 (44)
	5 to 25		60 (2.36)	9 (0.35)	
	150 to 360		70 (2.76)	9 (0.35)	
5GV□B 5GVH□B	2, 3, 25 to 100	M8	85 (3.35)	16 (0.63)	12.0 (106)
	5 to 18		70 (2.76)	14 (0.55)	
	120 to 300		90 (3.54)	15 (0.59)	
5GVR□B	2, 3, 18 to 36	M8	85 (3.35)	16 (0.63)	12.0 (106)
	5 to 15		70 (2.76)	14 (0.55)	
	50 to 180		95 (3.74)	14 (0.55)	

* Included with gearheads (sold separately)

■ Round shaft type

Secure the motor with hexagonal socket head screws (not included) through the four mounting holes provided. Do not leave a gap between the motor and mounting plate.

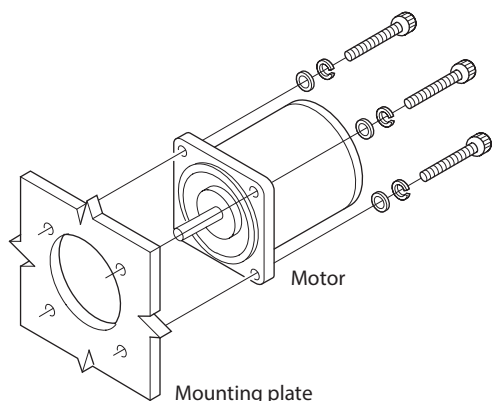

Motor model	Screw size	Tightening torque
SCM26	M4	1.8 N·m (15.9 lb-in) [1.4 N·m (12.3 lb-in)]
SCM315 SCM425	M5	3.8 N·m (33 lb-in) [3.0 N·m (26 lb-in)]
SCM540 SCM560 SCM590	M6	6.4 N·m (56 lb-in) [5.0 N·m (44 lb-in)]

The number in parentheses [] indicates the value for stainless steel hexagonal socket head screw.

■ Motor with cooling fan

When installing a motor with cooling fan onto a device, leave 10 mm (0.39 in.) or more behind the fan cover or open a ventilation hole so that the cooling inlet on the back of the motor cover is not blocked.

5.3 Installing a load

The gearhead shaft is provided with a key slot for connecting the transmission parts. When connecting the transmission parts, ensure that the shaft and parts have a clearance fit, and always fix the parallel key to the output shaft with a screw to prevent the parts from rattling or spinning.

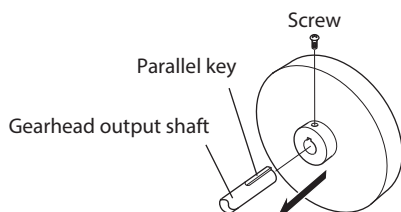

Do not apply excessive force onto the output shaft of the gearhead using a hammer or other tools. Doing so may cause damage to the output shaft or bearings.

■ When using the output shaft end tapped hole of a gearhead

Use a tapped hole provided at the end of the output shaft as an auxiliary means for preventing the transfer mechanism from disengaging.

2GV□B, 3GV□B type have no output shaft end tapped hole.

Gearhead model	Output shaft end tapped hole
4GV□B	M5, Effective depth 10 mm (0.39 in.)
5GV□B 5GVH□B 5GVR□B	M6, Effective depth 12 mm (0.47 in.)

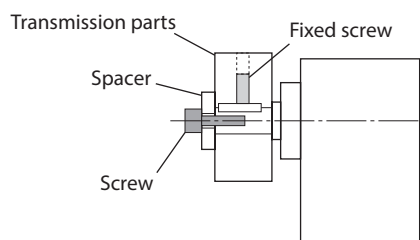

5.4 Permissible radial load and permissible axial load

The radial load and the axial load on the output shaft of the motor, gearhead must be kept under the permissible values listed below.

Note Failure due to fatigue may occur when the motor (gearhead) bearings and output shaft are subject to repeated loading by a radial or axial load that is in excess of the permissible limit.

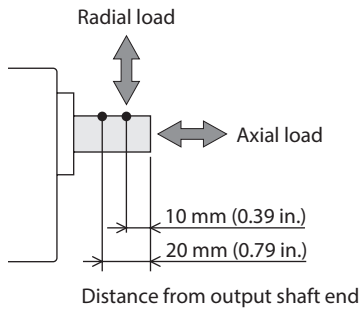

■ Parallel shaft gearhead

Gearhead model	Permissible radial load [N (lb.)]			Permissible axial load [N (lb.)]
	Gear ratio	Distance from tip of gearhead output shaft		
		10 mm (0.39 in.)	20 mm (0.79 in.)	
2GV□B	2	100 (22)	150 (33)	15 (3.3)
	3	100 (22)	150 (33)	30 (6.7)
	5 to 25	150 (33)	200 (45)	40 (9.0)
	30 to 360	200 (45)	300 (67)	
3GV□B	2	150 (33)	250 (56)	20 (4.5)
	3	150 (33)	250 (56)	40 (9.0)
	5 to 25	200 (45)	300 (67)	80 (18.0)
	30 to 360	300 (67)	400 (90)	
4GV□B	2	300 (67)	350 (78)	25 (5.6)
	3	300 (67)	350 (78)	50 (11.2)
	5 to 25	300 (67)	350 (78)	100 (22)
	30 to 360	450 (101)	550 (123)	
5GV□B 5GVH□B	2	250 (56)	350 (78)	100 (22)
	3 to 9	400 (90)	500 (112)	150 (33)
	12.5 to 18	450 (101)	600 (135)	
5GVR□B	25 to 300	500 (112)	700 (157)	150 (33)
	2	250 (56)	350 (78)	
	3 to 9	400 (90)	500 (112)	
	12.5 to 18	450 (101)	600 (135)	
5GVR□B	25 to 180	500 (112)	700 (157)	150 (33)
	2	250 (56)	350 (78)	
	3 to 9	400 (90)	500 (112)	
	12.5 to 18	450 (101)	600 (135)	

■ Round shaft type

Motor model	Permissible radial load [N (lb.)]		Permissible axial load [N (lb.)]
	Distance from output shaft end of the motor		
	10 mm	20 mm	
SCM26	50 (11.2)	110 (24)	Not to exceed one-half the motor's mass*
SCM315	40 (9.0)	60 (13.5)	
SCM425	90 (20)	140 (31)	
SCM540	140 (31)	200 (45)	
SCM560	240 (54)	270 (60)	
SCM590			

* Minimize the axial load. If an axial load must be applied, do not let it exceed one-half the motor's mass.

6 Grounding

Ground close to the motor at a shortest distance using the Protective Earth Terminal (PE) of the motor.

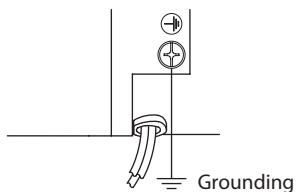

■ Ground terminal

Use a crimp terminal described below for grounding.

- Applicable crimp terminal: Round crimp terminal with insulation cover
- Thread size of terminal: M4
- Tightening torque: 1.0 to 1.3 N·m (8.8 to 11.5 lb-in)
- Applicable lead wire: AWG18 (0.75 mm²) or thicker

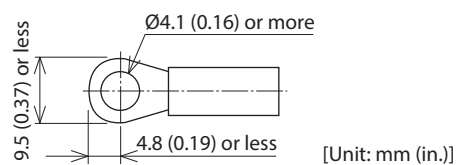

Note Be sure to use the screw for grounding attached on the product.

7 Maintenance · inspection

7.1 Inspection

It is recommended that periodic inspections would be conducted for the items listed below after each operation of the motor. If an abnormal condition is noted, discontinue any use and contact your nearest Oriental Motor sales office.



Do not conduct the insulation resistance measurement or dielectric strength test with the motor and speed controller connected. Doing so may cause damage to the product.

■ Inspection item

- Check if any of the mounting screws of the motor and gearhead are loose.
- Check if the bearing part (ball bearings) of the motor generates unusual noises.
- Check if the bearing part (ball bearings) or gear meshing part of the gearhead generates unusual noises.
- Check if the output shaft of the motor and gearhead and a load shaft are out of alignment.
- Check if a damage or stress is applied on the cable or the connection part between the cable and speed controller is loose.

7.2 Warranty

Check on the Oriental Motor Website for the product warranty.

7.3 Disposal

Dispose the product correctly in accordance with laws and regulations, or instructions of local governments.

8 Specifications

8.1 Specifications

Check on the Oriental Motor Website for the product specifications.

8.2 General specifications

Operation environment	Ambient temperature	Classification representing the power supply voltage JA/JC: -10* to +50 °C (+14 to +122 °F) (non-freezing) UA/EC: -10* to +40 °C (+14 to +104 °F) (non-freezing) * The lowest temperature is 0 °C (+32 °F) for gearheads of the gear ratio 2 and 3 .
	Ambient Humidity	85% or less (non-condensing)
	Altitude	Up to 1000 m (3300 ft.) above sea level
	Surrounding atmosphere	No corrosive gas, dust, water or oil. Cannot be used in radioactive materials, magnetic field, vacuum or other special environment.
	Vibration	Not subject to continuous vibrations or excessive impact. In conformance with JIS C 60068-2-6 "Sinewave vibration test method" Frequency range: 10 to 55 Hz Pulsating amplitude: 0.15 mm (0.006 in.) Sweep direction: 3 directions (X, Y, Z) Number of sweeps: 20 times
Storage environment	Ambient temperature	-25 to +70 °C [-13 to +158 °F] (non-freezing)
	Ambient Humidity	85% or less (non-condensing)
Shipping environment	Altitude	Up to 3000 m (10000 ft.) above sea level
	Surrounding atmosphere	No corrosive gas, dust, water or oil. Cannot be used in radioactive materials, magnetic field, vacuum or other special environment.
Overheat Protection Device	SCM26: Impedance protected Other motors: Built-in thermal protector (automatic return type) Open (motor standstill).....130±5 °C (266±9 °F) Close (resuming operation)85±20 °C (185±36 °F)	
Degree of protection	IP20	

8.3 Time rating

Continuous operation is possible (continuous rating).

9 Regulations and standards

Check on the Oriental Motor Website for the regulations and standards.

■ UL Standards, CSA Standards

This product is recognized by UL under the UL and CSA Standards.

■ CCC System

This product is affixed the CCC Mark under the China Compulsory Certification System.
It is also certified by CQC.

■ CE Marking

This product is affixed with the marks under the following directives.

● Low Voltage Directive

Installation conditions

- For incorporating in equipment
- Overvoltage category: II
- Pollution degree: 2
- Protection against electric shock: Class I

Momentary excess torque based on EN 60034-1

Motor model	Momentary excess torque
SCM315 SCM560	120% of the rated torque
SCM26 SCM425 SCM540 SCM590	130% of the rated torque

Momentary excess torque represents a maximum torque that can maintain the operation for 15 seconds without stalling or abrupt speed change even if the torque is increased gently while operating at rated voltage and rated frequency.

■ Motor temperature rise tests

Temperature rise tests stipulated in the standards are conducted in a condition where a motor is mounted on a heat radiation plate instead of attaching a gearhead.

The size and material for the heat radiation plates are as follows.

Motor model	Size	Thickness	[mm (in.)]
			Material
SCM26	115×115 (4.53×4.53)	5 (0.20)	Aluminum alloy
SCM315	125×125 (4.92×4.92)		
SCM425	135×135 (5.31×5.31)		
SCM540	165×165 (6.50×6.50)		
SCM560 SCM590	200×200 (7.87×7.87)		

■ RoHS Directive

This product does not contain the substances exceeding the restriction values.

- Unauthorized reproduction or copying of all or part of this manual is prohibited.
If a new copy is required to replace an original manual that has been damaged or lost, please contact your nearest Oriental Motor sales office.
- Oriental Motor shall not be liable whatsoever for any problems relating to industrial property rights arising from use of any information, circuit, equipment or device provided or referenced in this manual.
- Characteristics, specifications and dimensions are subject to change without notice.
- While we make every effort to offer accurate information in the manual, we welcome your input. Should you find unclear descriptions, errors or omissions, please contact the nearest office.
- **Oriental motor** is a registered trademark or trademark of Oriental Motor Co., Ltd., in Japan and other countries.
Other product names and company names mentioned in this manual may be registered trademarks or trademarks of their respective companies and are hereby acknowledged. The third-party products mentioned in this manual are recommended products, and references to their names shall not be construed as any form of performance guarantee.
Oriental Motor is not liable whatsoever for the performance of these third-party products.

© Copyright ORIENTAL MOTOR CO., LTD. 2023

Published in July 2025

- Please contact your nearest Oriental Motor office for further information.

ORIENTAL MOTOR U.S.A. CORP.
Technical Support Tel:800-468-3982
8:30am EST to 5:00pm PST (M-F)

ORIENTAL MOTOR (EUROPA) GmbH
Schiessstraße 44, 40549 Düsseldorf, Germany
Technical Support Tel:00 800/22 55 66 22

ORIENTAL MOTOR (UK) LTD.
Blythe Valley Business Park,
Central Blvd Blythe Valley Park,
Solihull B90 8AG, United Kingdom
Tel:+44-1926-671220

ORIENTAL MOTOR (FRANCE) SARL
Tel:+33-1 47 86 97 50

ORIENTAL MOTOR ITALIA s.r.l.
Tel:+39-02-93906347

ORIENTAL MOTOR ASIA PACIFIC PTE. LTD.
Singapore
Tel:1800-842-0280

ORIENTAL MOTOR (MALAYSIA) SDN. BHD.
Tel:1800-806-161

ORIENTAL MOTOR (THAILAND) CO., LTD.
Tel:1800-888-881

ORIENTAL MOTOR (INDIA) PVT. LTD.
Tel:1800-120-1995 (For English)
1800-121-4149 (For Hindi)

TAIWAN ORIENTAL MOTOR CO., LTD.
Tel:0800-060708

SHANGHAI ORIENTAL MOTOR CO., LTD.
Tel:400-820-6516

INA ORIENTAL MOTOR CO., LTD.
Korea
Tel:080-777-2042

ORIENTAL MOTOR CO., LTD.
4-8-1 Higashiueno, Taito-ku, Tokyo
110-8536 Japan
Tel:+81-3-6744-0361
www.orientalmotor.co.jp/ja