



5-Phase Stepping Motor Unit UPK·W Series

OPERATING MANUAL



Thank you for purchasing an Oriental Motor product.

This Operating Manual describes product handling procedures and safety precautions.

- Please read it thoroughly to ensure safe operation.
- Always keep the manual where it is readily available.

Table of contents

1	Introduction	2	6.4	Connecting the motor	23
2	Safety precautions	4	6.5	Grounding method.....	23
3	Precautions for use.....	6	6.6	Connecting the input/output signals	24
4	Preparation	8	6.7	About input/output signals	25
4.1	Checking the product	8	6.8	Timing chart.....	29
4.2	How to identify the product model.....	9	7	Setting.....	30
4.3	Combinations of motors and drivers	10	7.1	Step angle.....	30
4.4	Names and functions of parts.....	13	7.2	Motor currents	30
5	Installation.....	16	7.3	Pulse input mode.....	32
5.1	Location for installation.....	16	7.4	Automatic current off function.....	32
5.2	Installing the motor	16	7.5	Electromagnetic brake function (motors with an electromagnetic brake only).....	32
5.3	Installing a load	17	8	Overheat protection function	34
5.4	Permissible overhung load and permissible thrust load	18	9	Inspection	35
5.5	Installing the driver	19	10	Troubleshooting and remedial actions	36
6	Connection.....	20	11	Specifications	38
6.1	Connection example for a standard type.....	20	12	Option (sold separately).....	39
6.2	Connection example for a standard type with electromagnetic brake.....	21			
6.3	Connecting the power supply.....	22			

1 Introduction

■ Before use

Only qualified personnel should work with the product.

Use the product correctly after thoroughly reading the section “2 Safety precautions” on p.4.

The product described in this manual has been designed and manufactured for use in general industrial machinery, and must not be used for any other purpose. Oriental Motor Co., Ltd. is not responsible for any damage caused through failure to observe this warning.

■ Overview of the product

The 5-phase stepping motor unit **UPK-W** series are unit products consisting of a driver equipped with vibration suppression circuit and a 5-phase stepping motor of high-torque, low-vibration design.

■ System configuration

Controllers with pulse output functions are needed to operate the 5-phase stepping motor unit **UPK-W** series

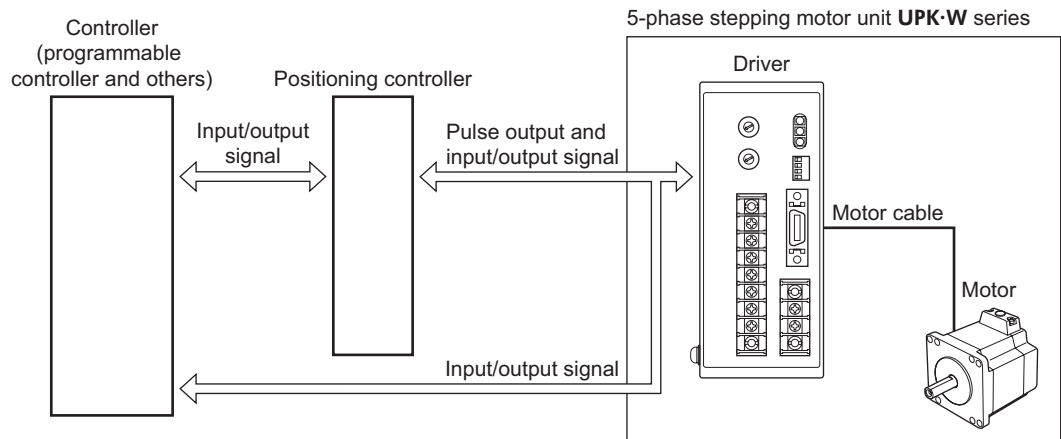

■ Standards and CE Marking

This product is recognized by UL and certified by CSA, and bears the CE Marking (Low Voltage Directive) in compliance with the EN Standards.

• Applicable Standards

	Applicable Standards	Certification Body	Standards File No.
Motor	UL 1004, UL 2111 CSA C22.2 No.100* ¹ CSA C22.2 No.77* ¹	UL	E64199
	EN 60950 EN 60034-1 EN 60034-5	VDE* ²	License No.114293ÜG
Driver	UL 508C* ³ CSA C22.2 No.14	UL	E171462
	EN 60950 EN 50178	Conforming to the respective standards.	

*1 Excluding **UPK54□**.

*2 **UPK54□** only (standard type, standard type with electromagnetic brake, **TH** geared type and **PL** geared type).

*3 For UL Standard (UL 508C), the product is recognized for the condition of Maximum Surrounding Air Temperature 50 °C (122 °F).

- The names of products certified to conform with relevant standards are represented by applicable unit model motor and driver part numbers.
- The temperature-rise test, as required by the VDE Standards, is conducted with the aluminum heat sink attached. The size and thickness of the heat sink are as described below.

Motor frame size [mm (in.)]	Size [mm (in.)]	Thickness [mm (in.)]
□42 (1.65)	80 × 80 (3.15 × 3.15)	10 (0.39)
□60 (2.36)	160 × 160 (6.30 × 6.30)	
□85 (3.35), □90 (3.54)	250 × 250 (9.84 × 9.84)	

- **Installation conditions**

Motor is to be used as a component within other equipment.

Overvoltage category: II

Pollution degree: 2

Protection against electric shock: Class I



- **For Low Voltage Directive**

This product is designed for use as a built-in component.

- Install the product within an enclosure in order to avoid contact with the hands.
- Be sure to maintain a Protective Earth in case the hands should make contact with the product. Securely ground the Protective Earth Terminals of the motor and driver.



2 Safety precautions

The precautions described below are intended to prevent danger or injury to the user and other personnel through safe, correct use of the product. Use the product only after carefully reading and fully understanding these instructions.

 Warning	Handling the product without observing the instructions that accompany a “Warning” symbol may result in serious injury or death.
 Caution	Handling the product without observing the instructions that accompany a “Caution” symbol may result in injury or property damage.
Note	The items under this heading contain important handling instructions that the user should observe to ensure safe use of the product.

Warning

General

- Do not use the product in explosive or corrosive environments, in the presence of flammable gases, locations subjected to splashing water, or near combustibles. Doing so may result in fire, electric shock or injury.
- Assign qualified personnel the task of installing, wiring, operating/controlling, inspecting and troubleshooting the product. Failure to do so may result in fire, electric shock, injury or damage to equipment.
- Do not transport, install the product, perform connections or inspections when the power is on. Always turn the power off before carrying out these operations. Failure to do so may result in electric shock.
- The terminals on the driver’s front panel marked with a   symbol indicate the presence of high voltage. Do not touch these terminals while the power is on to avoid the risk of fire or electric shock.
- Provide a means to hold the moving parts in place for applications involving vertical travel. The motor loses holding torque when the power is shut off, allowing the moving parts to fall and possibly causing injury or damage to equipment.
- Do not use the motor’s built-in electromagnetic brake mechanism for stopping or for safety purposes. Using it for purposes other than holding the moving parts and motor in position may cause injury or damage to equipment.
- When the driver’s overheat-protection function is triggered, shut off the power immediately. Turn the power back on only after determining the cause. Continuing the operation without determining the cause of the problem may cause malfunction of the motor, leading to injury or damage to equipment.

Installation

- To prevent the risk of electric shock, use the motor and driver for class I equipment only.
- Install the motor and driver in their enclosures in order to prevent electric shock or injury.
- Install the motor and driver so as to avoid contact with hands, or ground them to prevent the risk of electric shock.

Connection

- Keep the driver’s input power voltage within the specified range to avoid fire and electric shock.
- Connect the cables securely according to the wiring diagram in order to prevent fire and electric shock.
- Do not forcibly bend, pull or pinch the cable. Doing so may fire and electric shock.
- To prevent electric shock, be sure to install the terminal cover (supplied) over the driver’s power supply terminals after making connections.

Operation

- Turn off the driver power in the event of a power failure, or the motor may suddenly start when the power is restored and may cause injury or damage to equipment.
- To prevent injury or equipment damage, never turn ON the C.OFF input when the motor is installed vertically, whether the motor is operating or stopped.
- Provide a measure to detect an alarm output upon actuation of the driver’s overheat protection function and stop the motor when the automatic current off function is cancelled. Failure to do so may result in fire.
- Do not turn the output current off input to ON while the motor is operating. If the input is turned ON, the motor will stop and lose its holding capability, causing possible injury or equipment damage.

- Implement a measure to hold the moving part in position upon actuation of the driver's overheat protection function when the automatic current off function is enabled. If the input is turned ON, the motor will stop and lose its holding capability, causing possible injury or equipment damage.
- If the POWER LED on the driver is not lit after turning on the power, turn off the power immediately. This may be caused by a blown fuse in the neutral line, with the fuse in the live (phase) line intact. Since this condition can cause electric shock, contact the Oriental Motor branch or sales office where you purchased your **UPK·W** series, and request repair.

Maintenance and inspection

- Do not touch the connection terminals of the driver immediately after the power is turned off (for a period of 30 seconds). The residual voltage may cause electric shock.

Repair, disassembly and modification

- Do not disassemble or modify the motor or driver. This may cause electric shock or injury. Refer all such internal inspections and repairs to the branch or sales office from which you purchased the product.



General

- Do not use the motor and driver beyond their specifications, or electric shock, injury or damage to equipment may result.
- Keep your fingers and objects out of the openings in the motor and driver, or fire, electric shock or injury may result.
- Do not touch the motor or driver during operation or immediately after stopping. The surfaces are hot and may cause a skin burn(s).

Transportation

- Do not hold the motor output shaft or motor cable. This may cause injury.

Installation

- Keep the area around the motor and driver free of combustible materials in order to prevent fire.
- To prevent the risk of damage to equipment, leave nothing around the motor and driver that would obstruct ventilation.
- Provide a cover over the rotating parts (output shaft) of the motor to prevent injury.

Operation

- Use a motor and driver only in the specified combination. An incorrect combination may cause a fire.
- Before supplying power to the driver, turn all input signals to the driver to OFF. Otherwise, the motor may start suddenly and cause injury or damage to equipment.
- To prevent bodily injury, do not touch the rotating parts (output shaft) of the motor during operation.
- When turning ON the electromagnetic brake release input, make sure the motor output shaft will not turn. Since the motor will lose its holding torque when this input is turned ON, injury or equipment damage may occur if the output shaft is allowed to turn.
- Before moving the motor with the hands (as in the case of manual positioning), confirm that the driver output current off input is ON prevent injury.
- Provide an emergency-stop device or emergency-stop circuit external to the equipment so that the entire equipment will operate safely in the event of a system failure or malfunction. Failure to do so may result in injury.
- Immediately when trouble has occurred, stop running and turn off the driver power. Failure to do so may result in fire, electric shock or injury.
- To prevent electric shock, use only an insulated screwdriver to adjust the driver switches.
- When operating the key-equipped motor by itself, be sure the key inserted into the output shaft is fixed in position. Failure to do so may result in injury if the key should fly out.

Maintenance and inspection

- To prevent the risk of electric shock, do not touch the terminals while measuring the insulation resistance or conducting a voltage-resistance test.

Disposal

- To dispose of the motor or driver, disassemble it into parts and components as much as possible and dispose of individual parts/components as industrial waste.

3 Precautions for use

This section covers limitations and requirements the user should consider when using the 5-phase stepping motor unit **UPK·W** series.

- **Conduct the insulation resistance measurement or withstand voltage test separately on the motor and the driver.**
 Conducting the insulation resistance measurement or withstand voltage test with the motor and driver connected may result in injury or damage to equipment.
- **Do not apply an overhung load and thrust load in excess of the specified permissible limit.**
 Be sure to operate the motor within the specified permissible limit of overhung load and thrust load. Operating it under an excessive overhung load and thrust load may damage the motor bearings (ball bearings).
- **Operate the motor with a surface temperature not exceeding 100 °C (212 °F).**
 The driver has an overheat-protection function, but the motor has no such feature. The motor casing's surface temperature may exceed 100 °C (212 °F) under certain conditions (ambient temperature, operating speed, duty cycle, etc.). Keeping the surface temperature of the motor casing below 100 °C (212 °F) will also maximize the life of the motor bearings (ball bearings). When a harmonic geared type is used, make sure the gear case temperature is kept at 70 °C (158 °F) or below.
- **Maximum static torque at excitation**
 Maximum static torque at excitation represents a value obtained when the motor is excited using the rated current. When the motor is combined with a dedicated driver, the maximum static torque at excitation drops to approximately 50% due to the current cutback function that suppresses the rise in motor temperature in a standstill state. Acceleration and operation at the maximum static torque at excitation is possible in start-up, but it only has approximately 50% holding power after it has stopped.
 When selecting a motor for your application, consider the fact that the holding power will be reduced to approximately 50% after the motor has stopped.
- **Install the driver in a vertical position.**
 The driver's heat-dissipation function is designed according to vertical orientation. Installing the driver in any other orientation may shorten the life of electronic parts due to temperature increases within the driver.
- **Use the motor equipped with an electromagnetic brake for an application involving vertical travel.**
 For an application involving vertical travel, select a motor equipped with an electromagnetic brake so that the load can be held in position. Use the electromagnetic brake to hold the load only after the motor stops. Do not use the electromagnetic brake for the purpose of stopping the motor. Repeated use of the electromagnetic brake for the purpose of stopping may cause excessive wear in the brake hub, thus reducing the brake's holding capability. Since the electromagnetic brake is of the non-excitation type, it can also be used to hold the load in position in the event of a power failure. However, do not use the electromagnetic brake as a safety brake of your equipment, since it is not designed as a mechanism capable of securely holding the load.
- **Connecting a motor with an electromagnetic brake**
 The electromagnetic brake operates via the ON/OFF status of the driver's internal DC power supply. When connecting the motor, verify that the connection for the electromagnetic brake's lead wires has the correct polarity.
- **Preventing leakage current**
 Stray capacitance exists between the driver's current-carrying line and other current-carrying lines, the earth and the motor, respectively. A high-frequency current may leak out through such capacitance, having a detrimental effect on the surrounding equipment. The actual leakage current depends on the driver's switching frequency, the length of wiring between the driver and motor, and so on.
 When providing a leakage current breaker, use the following products, for instance, which have high-frequency signal protection:
 Mitsubishi Electric Corporation: NV series
 Fuji Electric FA Components & Systems Co., Ltd.: EG and SG series

- **Preventing electrical noise**

Take the following anti-noise measures to prevent malfunction of the motor and driver due to external noise.

Wiring the motor

Use braided-screen cable for connection between the motor and driver.

Wiring the input/output cables

- Minimize the length of the input/output cables.
 - Wire the input/output cables by maintaining a minimum distance of 300 mm (11.81 in.) from the inductive loads of electromagnetic relays, etc., as well as the power lines of the power source, motor and the like.
- Do not wire the input/output cables in the same duct or pipe in which power lines are wired.

Connecting noise filter for power supply line

Insert a noise filter in the driver's AC power supply input part to prevent noise from propagating to the driver and peripherals through the power supply line.

Ground the noise filter using the cable of AWG16 (wire diameter of 1.25 mm²) or more.

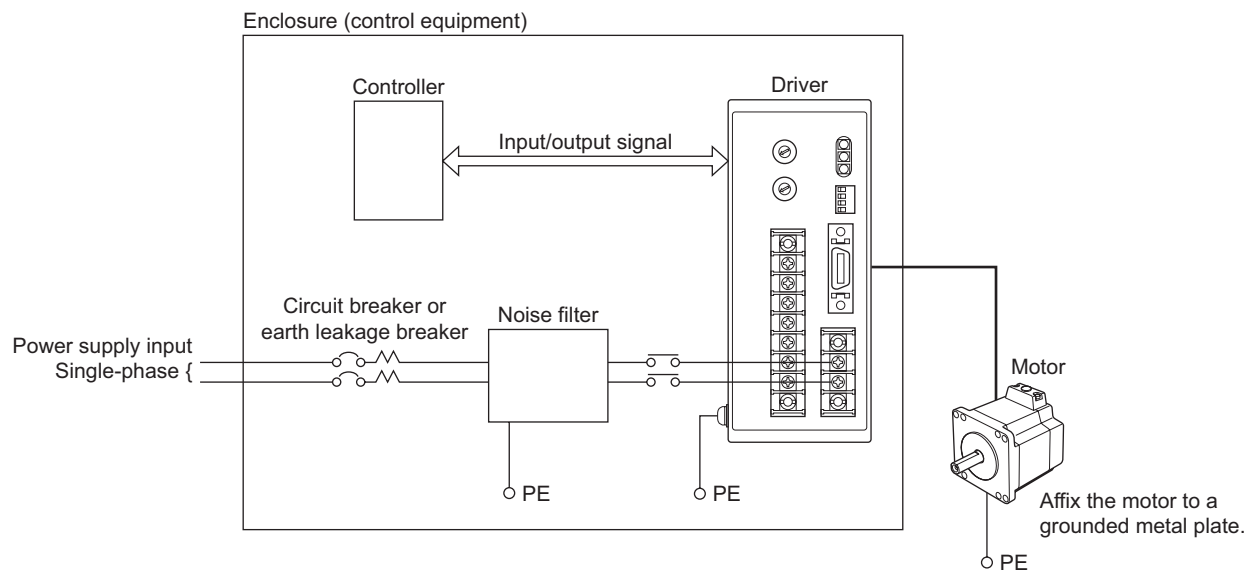

- **Maximum torque of geared motor**

Always operate geared types with loads not exceeding their maximum torque. If a geared type is operated with a load exceeding the maximum torque, the gear will be damaged.

- **Grease of geared motor**

On rare occasions, a small amount of grease may ooze out from of the geared motor. If there is concern over possible environmental damage resulting from the leakage of grease, check for grease stains during regular inspections. Alternatively, install an oil pan or other device to prevent leakage from causing further damage. Oil leakage may lead to problems in the customer's equipment or products.

4 Preparation

This section covers the points to be checked along with the names and functions of respective parts.

4.1 Checking the product

Upon opening the package, verify that the items listed below are included.

Report any missing or damaged items to the branch or sales office from which you purchased the product.

Verify the model number of the purchased unit against the number shown on the package label.

Check the model number of the motor and driver against the number shown on the nameplate.

The unit models and corresponding motor/driver combinations are listed on p.10 below.

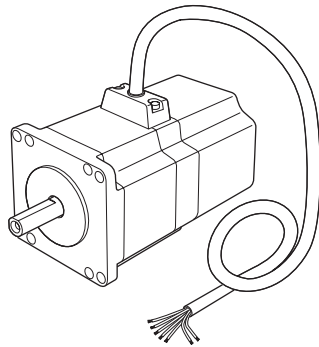

Motor 1 unit
Illustration shows the standard type with electromagnetic brake.

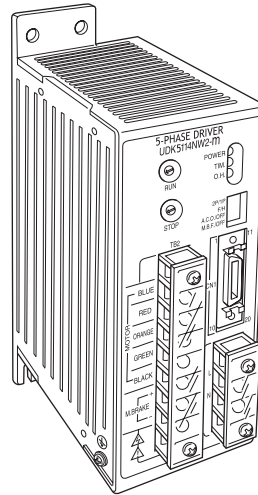

Driver 1 unit

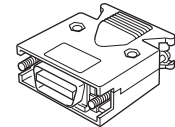

Input/output signal connector 1 set

Operating manual (this manual) 1 copy

- A parallel key (1 pc.) comes with all geared types (excluding **TH** geared types **UPK54□**, **UPK56□** and **PL** geared type **UPK54□**).
- All geared types (excluding the harmonic geared type) come with hexagonal socket head bolts (four pieces) for installing the motor.

4.2 How to identify the product model

■ Standard type, standard type with electromagnetic brake high-speed type, high-speed type with electromagnetic brake

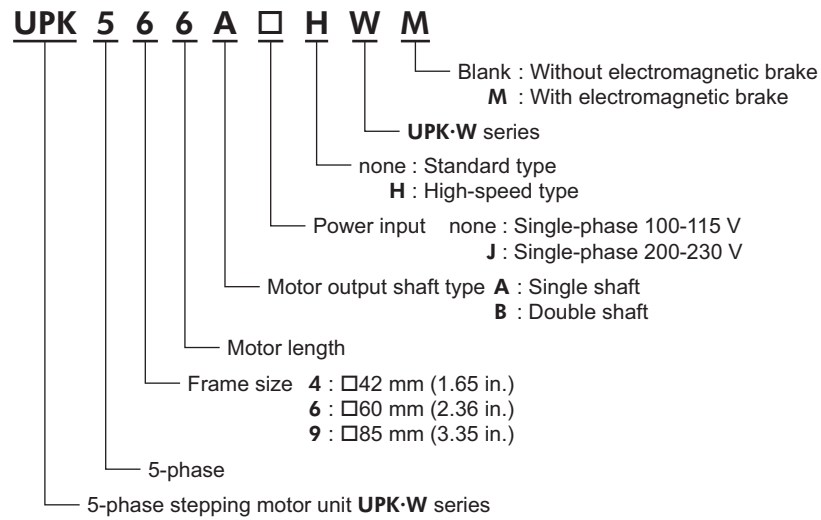

■ Geared type

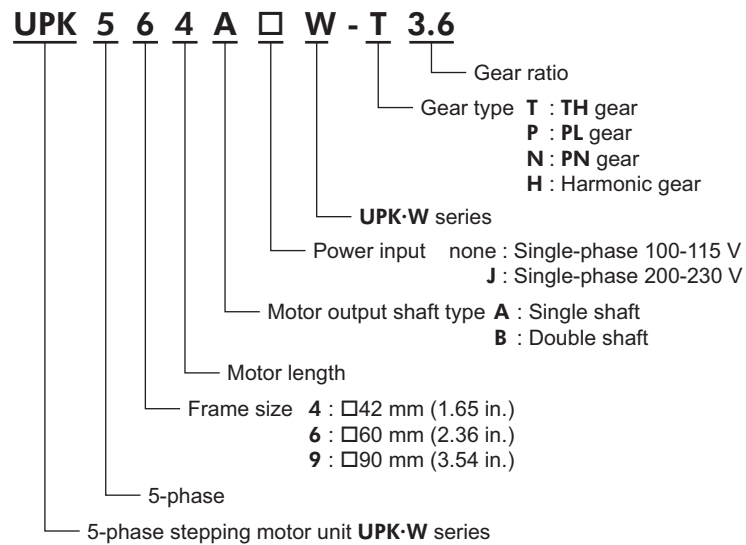

4.3 Combinations of motors and drivers

• Standard type

Unit model	Motor model	Driver model	
UPK543AW	PK543AW	UDK5107NW2	
UPK543BW	PK543BW		
UPK544AW	PK544AW		
UPK544BW	PK544BW		
UPK545AW	PK545AW		
UPK545BW	PK545BW		
UPK564AW2	PK564AW		UDK5114NW2
UPK564BW2	PK564BW		
UPK566AW2	PK566AW		
UPK566BW2	PK566BW		
UPK569AW2	PK569AW		
UPK569BW2	PK569BW		
UPK596AW2	PK596AW		
UPK596BW2	PK596BW		
UPK599AW2	PK599AW		
UPK599BW2	PK599BW		
UPK5913AW2	PK5913AW		
UPK5913BW2	PK5913BW		
UPK564AJW	PK564AW	UDK5214NW	
UPK564BJW	PK564BW		
UPK566AJW	PK566AW		
UPK566BJW	PK566BW		
UPK569AJW	PK569AW		
UPK569BJW	PK569BW		
UPK596AJW	PK596AW		
UPK596BJW	PK596BW		
UPK599AJW	PK599AW		
UPK599BJW	PK599BW		
UPK5913AJW	PK5913AW		
UPK5913BJW	PK5913BW		

• High-speed type

Unit model	Motor model	Driver model
UPK569AHW2	PK569AHW	UDK5128NW2
UPK569BHW2	PK569BHW	
UPK596AHW2	PK596AHW	
UPK596BHW2	PK596BHW	
UPK599AHW2	PK599AHW	
UPK599BHW2	PK599BHW	
UPK5913AHW2	PK5913AHW	
UPK5913BHW2	PK5913BHW	

• Standard type with electromagnetic brake

Unit model	Motor model	Driver model
UPK543AWM	PK543AWM	UDK5107NW2-M
UPK544AWM	PK544AWM	
UPK545AWM	PK545AWM	
UPK564AWM	PK564AWM	
UPK566AWM	PK566AWM	UDK5114NW2-M
UPK569AWM	PK569AWM	
UPK596AWM	PK596AWM	
UPK599AWM	PK599AWM	
UPK5913AWM	PK5913AWM	
UPK564AJWM	PK564AWM	UDK5214NW-M
UPK566AJWM	PK566AWM	
UPK569AJWM	PK569AWM	
UPK596AJWM	PK596AWM	
UPK599AJWM	PK599AWM	
UPK5913AJWM	PK5913AWM	

• High-speed type with electromagnetic brake

Unit model	Motor model	Driver model
UPK569AHWM	PK569AHWM	UDK5128NW2-M
UPK596AHWM	PK596AHWM	
UPK599AHWM	PK599AHWM	
UPK5913AHWM	PK5913AHWM	

• TH geared type

Unit model	Motor model	Driver model	Unit model	Motor model	Driver model
UPK543AW-T3.6	PK543AW-T3.6	UDK5107NW2	UPK596AW-T20	PK596AW1-T20	UDK5114NW2
UPK543BW-T3.6	PK543BW-T3.6		UPK596BW-T20	PK596BW1-T20	
UPK543AW-T7.2	PK543AW-T7.2		UPK596AW-T30	PK596AW1-T30	
UPK543BW-T7.2	PK543BW-T7.2		UPK596BW-T30	PK596BW1-T30	
UPK543AW-T10	PK543AW-T10		UPK564AJW-T3.6	PK564AW-T3.6	UDK5214NW
UPK543BW-T10	PK543BW-T10		UPK564BJW-T3.6	PK564BW-T3.6	
UPK543AW-T20	PK543AW-T20		UPK564AJW-T7.2	PK564AW-T7.2	
UPK543BW-T20	PK543BW-T20		UPK564BJW-T7.2	PK564BW-T7.2	
UPK543AW-T30	PK543AW-T30		UPK564AJW-T10	PK564AW-T10	
UPK543BW-T30	PK543BW-T30		UPK564BJW-T10	PK564BW-T10	
UPK564AW-T3.6	PK564AW-T3.6	UPK564AJW-T20	PK564AW-T20		
UPK564BW-T3.6	PK564BW-T3.6	UPK564BJW-T20	PK564BW-T20		
UPK564AW-T7.2	PK564AW-T7.2	UPK564AJW-T30	PK564AW-T30		
UPK564BW-T7.2	PK564BW-T7.2	UPK564BJW-T30	PK564BW-T30		
UPK564AW-T10	PK564AW-T10	UPK596AJW-T3.6	PK596AW-T3.6	UDK5114NW2	
UPK564BW-T10	PK564BW-T10	UPK596BJW-T3.6	PK596BW-T3.6		
UPK564AW-T20	PK564AW-T20	UPK596AJW-T7.2	PK596AW-T7.2		
UPK564BW-T20	PK564BW-T20	UPK596BJW-T7.2	PK596BW-T7.2		
UPK564AW-T30	PK564AW-T30	UPK596AJW-T10	PK596AW1-T10		
UPK564BW-T30	PK564BW-T30	UPK596BJW-T10	PK596BW1-T10		
UPK596AW-T3.6	PK596AW-T3.6	UPK596AJW-T20	PK596AW1-T20		
UPK596BW-T3.6	PK596BW-T3.6	UPK596BJW-T20	PK596BW1-T20		
UPK596AW-T7.2	PK596AW-T7.2	UPK596AJW-T30	PK596AW1-T30		
UPK596BW-T7.2	PK596BW-T7.2	UPK596BJW-T30	PK596BW1-T30		
UPK596AW-T10	PK596AW1-T10				
UPK596BW-T10	PK596BW1-T10				

• PL geared type

Unit model	Motor model	Driver model	
UPK545AW-P5	PK545AW-P5	UDK5107NW2	
UPK545BW-P5	PK545BW-P5		
UPK545AW-P7.2	PK545AW-P7.2		
UPK545BW-P7.2	PK545BW-P7.2		
UPK545AW-P10	PK545AW-P10		
UPK545BW-P10	PK545BW-P10		
UPK543AW-P25	PK543AW-P25		
UPK543BW-P25	PK543BW-P25		
UPK543AW-P36	PK543AW-P36		
UPK543BW-P36	PK543BW-P36		
UPK543AW-P50	PK543AW-P50		
UPK543BW-P50	PK543BW-P50		
UPK566AW-P5	PK566AW-P5		UDK5114NW2
UPK566BW-P5	PK566BW-P5		
UPK566AW-P7.2	PK566AW-P7.2		
UPK566BW-P7.2	PK566BW-P7.2		
UPK566AW-P10	PK566AW-P10		
UPK566BW-P10	PK566BW-P10		
UPK564AW-P25	PK564AW-P25		
UPK564BW-P25	PK564BW-P25		
UPK564AW-P36	PK564AW-P36		
UPK564BW-P36	PK564BW-P36		
UPK564AW-P50	PK564AW-P50		
UPK564BW-P50	PK564BW-P50		
UPK599AW-P5	PK599AW-P5		
UPK599BW-P5	PK599BW-P5		
UPK599AW-P7.2	PK599AW-P7.2		
UPK599BW-P7.2	PK599BW-P7.2		
UPK599AW-P10	PK599AW-P10		
UPK599BW-P10	PK599BW-P10		

Unit model	Motor model	Driver model
UPK596AW-P25	PK596AW-P25	UDK5114NW2
UPK596BW-P25	PK596BW-P25	
UPK596AW-P36	PK596AW-P36	
UPK596BW-P36	PK596BW-P36	
UPK596AW-P50	PK596AW-P50	
UPK596BW-P50	PK596BW-P50	
UPK566AJW-P5	PK566AW-P5	UDK5214NW
UPK566BJW-P5	PK566BW-P5	
UPK566AJW-P7.2	PK566AW-P7.2	
UPK566BJW-P7.2	PK566BW-P7.2	
UPK566AJW-P10	PK566AW-P10	
UPK566BJW-P10	PK566BW-P10	
UPK564AJW-P25	PK564AW-P25	
UPK564BJW-P25	PK564BW-P25	
UPK564AJW-P36	PK564AW-P36	
UPK564BJW-P36	PK564BW-P36	
UPK564AJW-P50	PK564AW-P50	
UPK564BJW-P50	PK564BW-P50	
UPK599AJW-P5	PK599AW-P5	
UPK599BJW-P5	PK599BW-P5	
UPK599AJW-P7.2	PK599AW-P7.2	
UPK599BJW-P7.2	PK599BW-P7.2	
UPK599AJW-P10	PK599AW-P10	
UPK599BJW-P10	PK599BW-P10	
UPK596AJW-P25	PK596AW-P25	
UPK596BJW-P25	PK596BW-P25	
UPK596AJW-P36	PK596AW-P36	
UPK596BJW-P36	PK596BW-P36	
UPK596AJW-P50	PK596AW-P50	
UPK596BJW-P50	PK596BW-P50	

• PN geared type

Unit model	Motor model	Driver model
UPK566AW-N5	PK566AW-N5	UDK5114NW2
UPK566BW-N5	PK566BW-N5	
UPK566AW-N7.2	PK566AW-N7.2	
UPK566BW-N7.2	PK566BW-N7.2	
UPK566AW-N10	PK566AW-N10	
UPK566BW-N10	PK566BW-N10	
UPK564AW-N25	PK564AW-N25	
UPK564BW-N25	PK564BW-N25	
UPK564AW-N36	PK564AW-N36	
UPK564BW-N36	PK564BW-N36	
UPK564AW-N50	PK564AW-N50	
UPK564BW-N50	PK564BW-N50	

Unit model	Motor model	Driver model
UPK566AJW-N5	PK566AW-N5	UDK5214NW
UPK566BJW-N5	PK566BW-N5	
UPK566AJW-N7.2	PK566AW-N7.2	
UPK566BJW-N7.2	PK566BW-N7.2	
UPK566AJW-N10	PK566AW-N10	
UPK566BJW-N10	PK566BW-N10	
UPK564AJW-N25	PK564AW-N25	
UPK564BJW-N25	PK564BW-N25	
UPK564AJW-N36	PK564AW-N36	
UPK564BJW-N36	PK564BW-N36	
UPK564AJW-N50	PK564AW-N50	
UPK564BJW-N50	PK564BW-N50	

• Harmonic geared type

Unit model	Motor model	Driver model
UPK543AW-H50	PK543AW1-H50	UDK5107NW2
UPK543BW-H50	PK543BW1-H50	
UPK543AW-H100	PK543AW1-H100	
UPK543BW-H100	PK543BW1-H100	
UPK564AW-H50	PK564AW2-H50	UDK5114NW2
UPK564BW-H50	PK564BW2-H50	
UPK564AW-H100	PK564AW2-H100	
UPK564BW-H100	PK564BW2-H100	
UPK596AW-H50	PK596AW1-H50	
UPK596BW-H50	PK596BW1-H50	

Unit model	Motor model	Driver model
UPK596AW-H100	PK596AW1-H100	UDK5114NW2
UPK596BW-H100	PK596BW1-H100	
UPK564AJW-H50	PK564AW2-H50	UDK5214NW
UPK564BJW-H50	PK564BW2-H50	
UPK564AJW-H100	PK564AW2-H100	
UPK564BJW-H100	PK564BW2-H100	
UPK596AJW-H50	PK596AW1-H50	
UPK596BJW-H50	PK596BW1-H50	
UPK596AJW-H100	PK596AW1-H100	
UPK596BJW-H100	PK596BW1-H100	

4.4 Names and functions of parts

■ Motor

Illustration shows the standard type with electromagnetic brake (**UPK56□**).

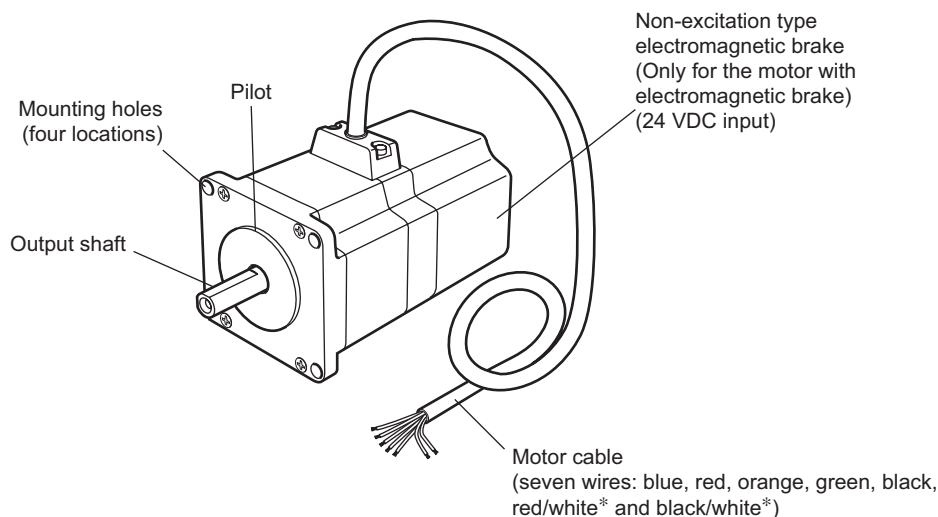

* motors with an electromagnetic brake only

Driver

Illustration shows the standard type with electromagnetic brake.

• Single-phase 100-115 V

• Single-phase 200-230 V

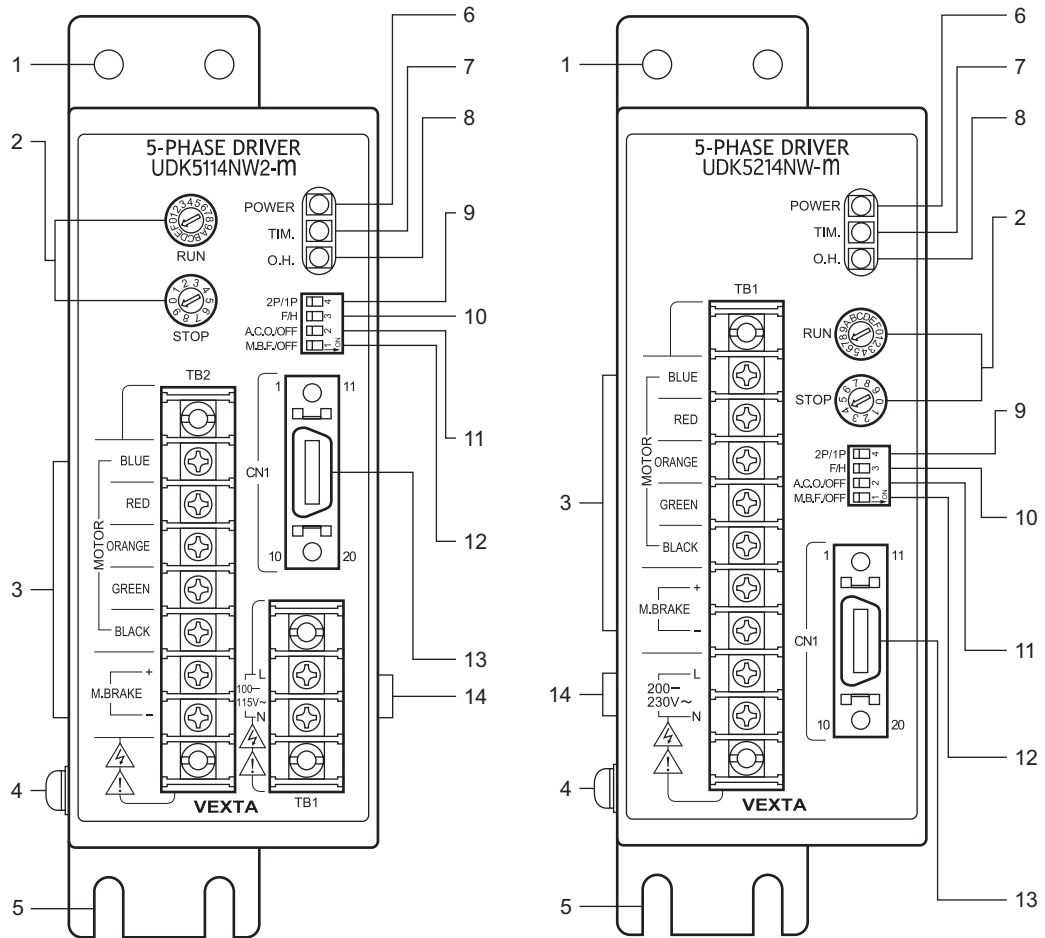

No.	Names	Description
1	Mounting holes	-
2	Motor current adjustment switches	RUN: Adjusts the motor's operating current. The factory setting is "F" (rated current). STOP: Adjusts the motor's standstill current between 7% and 50% (19% and 48% for single-phase 200-230 V) of operating current. The factory setting is "9", which is 50% (48% for single-phase 200-230 V) of operating current.
3	Motor connecting terminal	Connect the motor leads.
4	Protective Earth Terminal	Used for grounding via grounding wire of AWG18 (0.75 mm ²) or more
5	Mounting cutout	-
6	POWER LED (green)	Lit when the power is on.
7	TIM LED (green)	Lit when the excitation timing output is ON.
8	O.H. LED (red)	Lit when overheat protection is activated and the overheat output turns ON.
9	Pulse input mode select switch	Allows for the selection of 2-pulse input mode or 1-pulse input mode in accordance with the pulse output mode in the positioning controller. The factory setting is "2P" (2-pulse input mode).
10	Step angle select switches	Switches the motor step angle between full step and half step. The factory setting is "F" (full step).
11	Automatic current off function select switch	Set to "OFF" if continuous motor operation is desired when overheat protection is triggered. The factory setting is "A.C.O." (automatic current off).

No.	Names	Description
12	Electromagnetic brake function select switch (motors with an electromagnetic brake only)	Sets whether to operate the electromagnetic brake other than when the power is cut off. Set this switch to "OFF" if the position need not be held other than when the power is cut off. The factory setting is "M.B.F." (electromagnetic brake free).
13	Input/output connectors	Connect the input/output signals.
14	Power supply connecting terminal	Connect the power supply.

5 Installation

This section covers the environment and method of installing the motor and driver, along with load installation.

5.1 Location for installation

The motor and driver are designed and manufactured for installation in equipment. Install them in a well-ventilated location that provides easy access for inspection. The location must also satisfy the following conditions:

- Inside an enclosure that is installed indoors (provide vent holes)
- Operating ambient temperature
 - Motor: -10 to $+50$ °C ($+14$ to $+122$ °F) (non-freezing)
 - Harmonic geared type: 0 to $+40$ °C ($+32$ to $+104$ °F) (non-freezing)
 - Driver: 0 to $+50$ °C ($+32$ to $+122$ °F) (non-freezing)
- Operating ambient humidity 85% or less (non-condensing)
- Area that is free of explosive atmosphere or toxic gas (such as sulfuric gas) or liquid
- Area not exposed to direct sun
- Area free of excessive amount of dust, iron particles or the like
- Area not subject to splashing water (rains, water droplets), oil (oil droplets) or other liquids
- Area free of excessive salt
- Area not subject to continuous vibration or excessive shocks
- Area free of excessive electromagnetic noise (from welders, power machinery, etc.)
- Area free of radioactive materials, magnetic fields or vacuum
- 1000 m (3300 ft.) or lower above sea level

5.2 Installing the motor

■ Installation direction

The motor can be installed in any direction.

■ Installation method

Install the motor onto an appropriate flat metal plate having excellent vibration resistance and heat conductivity. When installing the motor, secure it with four bolts through the four mounting holes provided. Leave no gap between the motor and plate. All geared types (excluding the harmonic geared type) come with hexagonal socket head bolts.

Optional motor mounting brackets are available (sold separately).

Note Insert the pilot located on the motor's installation surface into the mounting plate's pilot holder.

- Installation method [A]

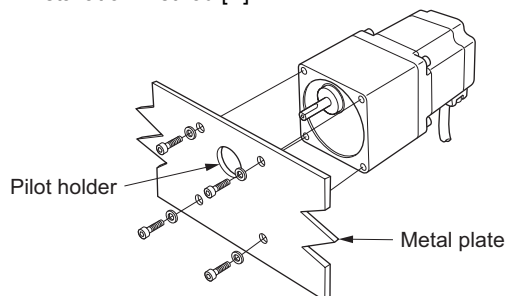

- Installation method [B]

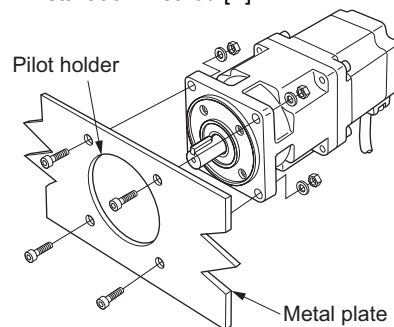

Motor type	Frame size [mm (in.)]	Bolt size	Tightening torque [N·m (oz-in)]	Effective depth of bolt [mm (in.)]	Type of installation
Standard type	□42 (1.65)	M3	1 (142)	4.5 (0.177)	A
Standard type with electromagnetic brake	□60 (2.36)	M4	2 (280)	-	B
High-speed type	□85 (3.35)	M5	3 (420)		
High-speed type with electromagnetic brake					
TH geared type	□42 (1.65)	M4	2 (280)	8 (0.315)	A
	□60 (2.36)				
	□90 (3.54)	M8	4 (560)	15 (0.591)	
PL geared type	□42 (1.65)	M4	2 (280)	8 (0.315)	A
PN geared type	□60 (2.36)	M5	2.5 (350)	10 (0.394)	
	□90 (3.54)	M8	4 (560)	15 (0.591)	
Harmonic geared type	□42 (1.65)	M4	2 (280)	-	B
	□60 (2.36)	M5	2.5 (350)		
	□90 (3.54)	M8	4 (560)		

5.3 Installing a load

When connecting a load to the motor, align the centers of the motor's output shaft and load shaft.

Also, keep the overhang load and thrust load to the permissible values or below.

Optional flexible couplings are available (sold separately).

Note

- When coupling the load to the motor, pay attention to the centering of the shafts, belt tension, parallelism of the pulleys, and so on. Securely tighten the coupling and pulley set screws.
- Be careful not to damage the output shaft or the bearings when installing a coupling or pulley to the motor's output shaft.
- Do not modify or machine the motor's output shaft. Doing so may damage the bearings and destroy the motor.
- When inserting a parallel key into the gear output shaft, do not apply excessive force by using a hammer or similar tool. Application of strong impact may damage the output shaft or bearings.

• Using a coupling

Align the centers of the motor's output shaft and load shaft in a straight line.

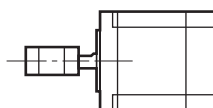

• Using a belt drive

Align the motor's output shaft and load shaft parallel with each other, and position both pulleys so that the line connecting their centers is at a right angle to the shafts.

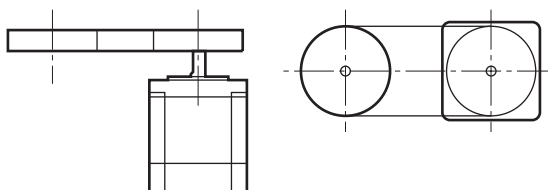

• Using a gear drive

Align the motor's output shaft and gear shaft parallel with each other, and let the gears mesh at the center of the tooth widths.

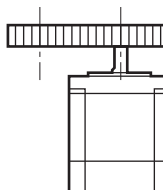

• Connecting with a key (Geared motor)

With a geared motor, to connect a load to the gear output shaft having a key groove, first provide a key groove on the load and fix the load with the gear output shaft using the supplied key.

5.4 Permissible overhung load and permissible thrust load

The overhung load and the thrust load on the motor's output shaft or gear output shaft must be kept within the permissible values listed below.

Note

Failure due to fatigue may occur if the motor's bearings and output shaft are subject to repeated loading by an overhung or thrust load that is in excess of the permissible limit.

Frame size [mm (in.)]	Unit model* ¹	Permissible overhung load [N (lb.)]					Permissible thrust load [N (lb.)] ^{*2*3}
		Distance from the tip of motor's output shaft					
		0 mm (0 in.)	5 mm (0.2 in.)	10 mm (0.39 in.)	15 mm (0.59 in.)	20 mm (0.79 in.)	
□42 (1.65)	UPK543						0.25 [0.37] (0.55 [0.81]) [*]
	UPK544	20 (4.5)	25 (5.6)	34 (7.6)	52 (11.7)	-	0.3 [0.42] (0.66 [0.92]) [*]
	UPK545						0.4 [0.52] (0.88 [1.14]) [*]
	UPK543-T□	10 (2.2)	14 (3.1)	20 (4.5)	30 (6.7)	-	15 (3.3)
	UPK545-P5						50 (11.2)
	UPK545-P7.2	73 (16.4)	84 (18.9)	100 (22)	123 (27)	-	
	UPK545-P10						
	UPK543-P25						
	UPK543-P36	109 (24)	127 (28)	150 (33)	184 (41)	-	
	UPK543-P50						
UPK543-H□	170 (38)	200 (45)	230 (51)	280 (63)	350 (78)	200 (45)	
□60 (2.36)	UPK564						0.6 [0.9] (1.3 [2.0]) [*]
	UPK566	63 (14.1)	75 (16.8)	95 (21)	130 (29)	190 (42)	0.8 [1.1] (1.8 [2.4]) [*]
	UPK569						1.3 [1.6] (2.9 [3.5]) [*]
	UPK564-T□	70 (15.7)	80 (18)	100 (22)	120 (27)	150 (33)	40 (9)
	UPK566-P5	200 (45)	220 (49)	250 (56)	280 (63)	320 (72)	100 (22)
	UPK566-P7.2	250 (56)	270 (60)	300 (67)	340 (76)	390 (87)	
	UPK566-P10						
	UPK564-P25						
	UPK564-P36	330 (74)	360 (81)	400 (90)	450 (101)	520 (117)	
	UPK564-P50						
	UPK566-N5	200 (45)	220 (49)	250 (56)	280 (63)	320 (72)	
	UPK566-N7.2	250 (56)	270 (60)	300 (67)	340 (76)	390 (87)	
	UPK566-N10						
	UPK564-N25						
	UPK564-N36	330 (74)	360 (81)	400 (90)	450 (101)	520 (117)	
UPK564-N50							
UPK564-H□	300 (67)	330 (74)	370 (83)	420 (94)	480 (108)	400 (90)	
□85 (3.35)	UPK596						1.7 [2.4] (3.7 [5.3]) [*]
	UPK599	260 (58)	290 (65)	340 (76)	390 (87)	480 (108)	2.8 [3.5] (6.2 [7.7]) [*]
	UPK5913						3.8 [4.5] (8.4 [9.9]) [*]
□90 (3.54)	UPK596-T□	220 (49)	250 (56)	300 (67)	350 (78)	400 (90)	100 (22)
	UPK599-P5						300 (67)
	UPK599-P7.2	480 (108)	540 (121)	600 (135)	680 (153)	790 (177)	
	UPK599-P10						
	UPK596-P25	850 (191)	940 (210)	1050 (230)	1190 (260)	1380 (310)	
	UPK596-P36	930 (200)	1030 (230)	1150 (250)	1310 (290)	1520 (340)	
	UPK596-P50	1050 (230)	1160 (260)	1300 (290)	1480 (330)	1710 (380)	
UPK596-H□	1090 (240)	1150 (250)	1230 (270)	1310 (290)	1410 (310)	1300 (290)	

*1 The square box in the unit type will contain a value representing the gear ratio.

*2 The figures indicated by * are the motor's mass [kg (lb.)]. The thrust load should not exceed the motor's dead mass.

*3 The figures in parenthesis [] are the values for the motor with electromagnetic brake.

5.5 Installing the driver

■ Installation direction

The driver is designed so that heat is dissipated via air convection and conduction through the enclosure.

When installing the driver in an enclosure, it must be placed in perpendicular (vertical) position using the four mounting holes provided in the driver.

■ Installation method

Install the driver on a flat metal plate having excellent vibration resistance and heat conductivity.

Install the driver by securing it with four bolts (M4, not supplied) through the four mounting holes provided. Leave no gap between the driver and plate.

There must be a clearance of at least 25 mm (0.98 in.) and 50 mm (1.97 in.) in the horizontal and vertical directions, respectively, between the driver and other equipment. When two or more drivers are to be installed side by side, provide 20 mm (0.79 in.) and 50 mm (1.97 in.) clearances in the horizontal and vertical directions, respectively.

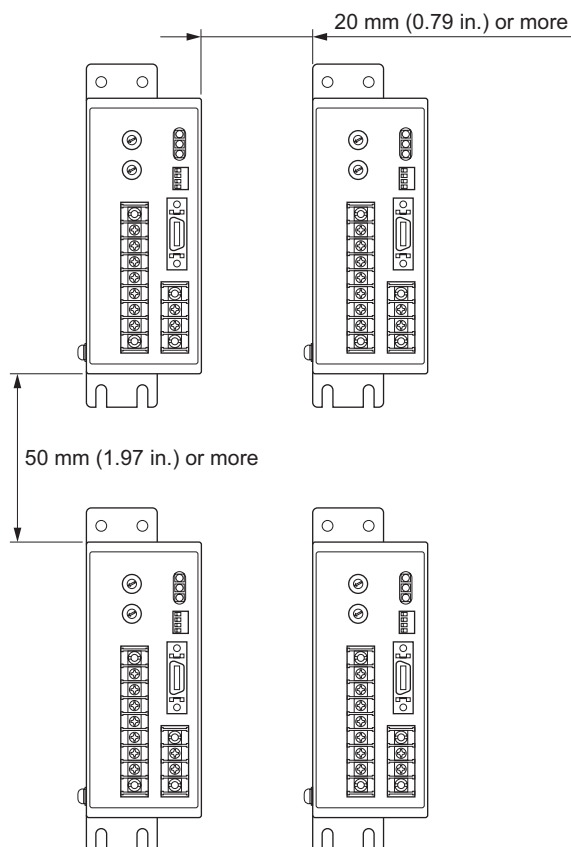

Note

- Install the driver in an enclosure.
- Do not install any equipment that generates a large amount of heat or noise near the driver.
- Do not install the driver beneath a controller or other equipment that is sensitive to heat.
- Check ventilation if the ambient temperature of the driver exceeds 50 °C (122 °F).

6 Connection

This section covers the methods and examples of connecting and grounding the driver, motor, power and controller, as well as the input/output signals.

6.1 Connection example for a standard type

Example of connection with a current sink output circuit

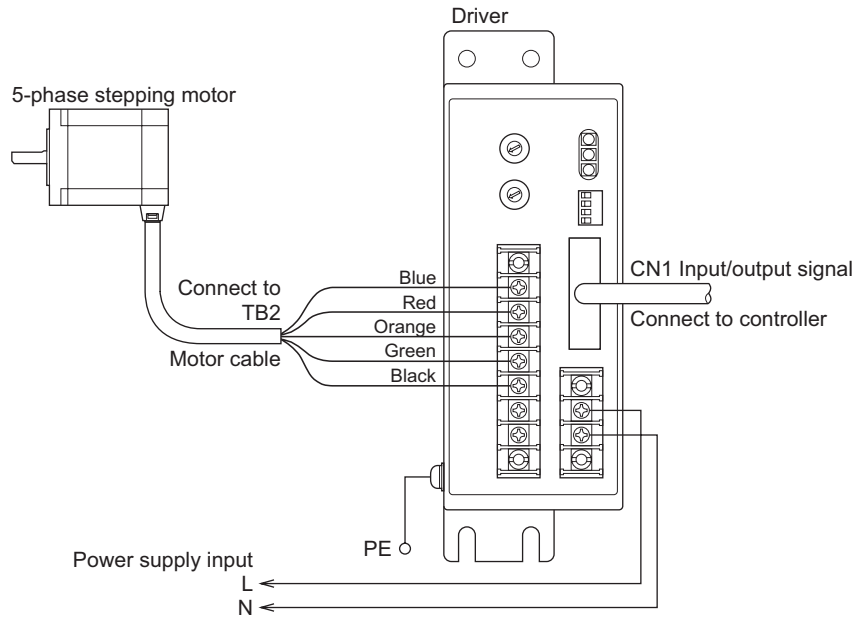

- Note**
- Use an input signal voltage of 5 VDC minimum and 24 VDC maximum. If the voltage exceeds 5 VDC, connect an external resistor to limit the input current to 10 to 20 mA.
 - Be certain the input/output signal cable that connects the driver and controller is as short as possible. The maximum input frequency will decrease as the cable length increases.

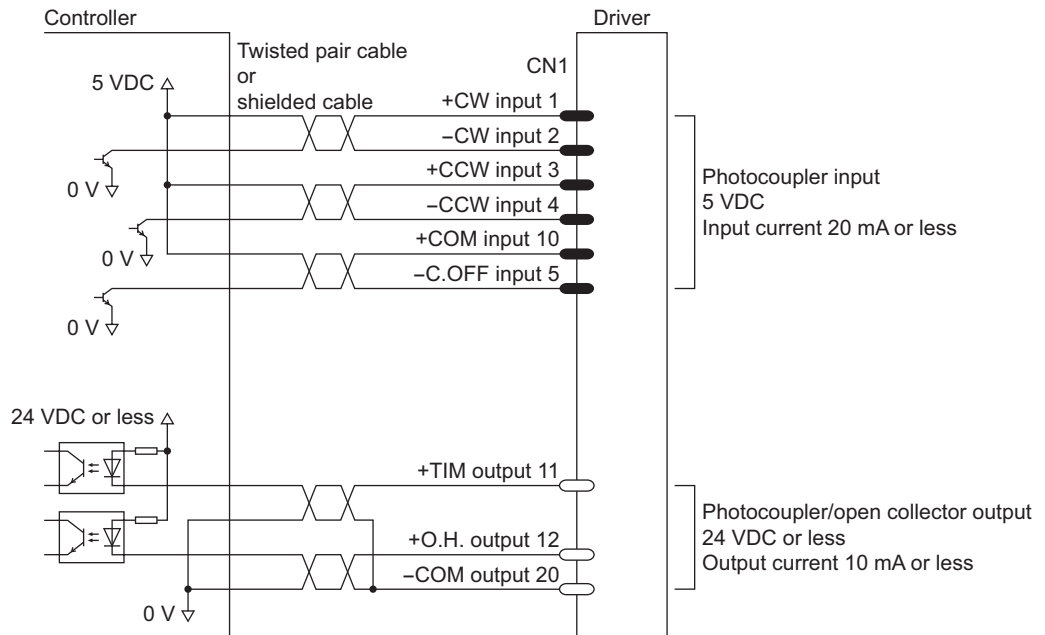

6.2 Connection example for a standard type with electromagnetic brake

Example of connection with a current sink output circuit

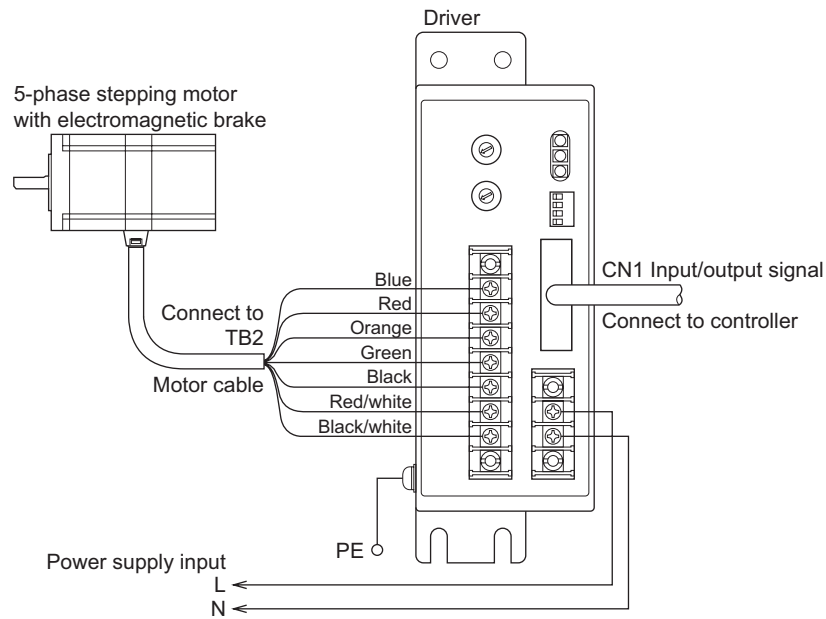

Note

- Use an input signal voltage of 5 VDC minimum and 24 VDC maximum. If the voltage exceeds 5 VDC, connect an external resistor to limit the input current to 10 to 20 mA.
- Be certain the input/output signal cable that connects the driver and controller is as short as possible. The maximum input frequency will decrease as the cable length increases.

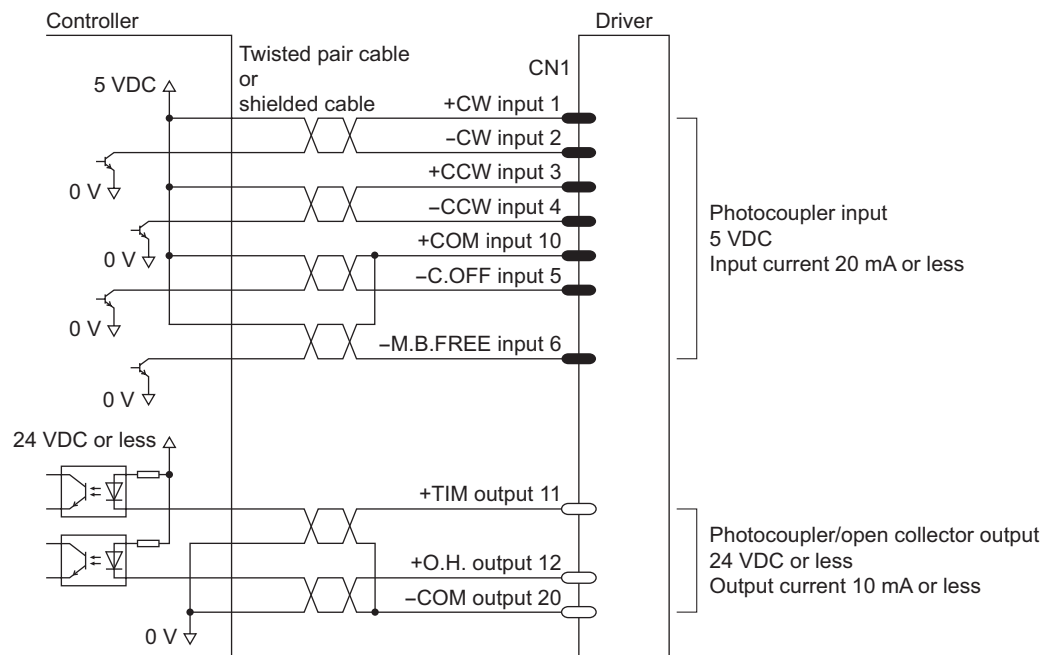

6.3 Connecting the power supply

- Note**
- Furnish a power supply capable of supplying adequate driver input current. If the current capacity is insufficient, the transformer may be damaged, or the motor may run erratically due to a drop in torque.
 - Do not run the driver's power cable through a conduit containing other power lines or motor cables.

■ Single-phase 100-115 V

Connect the live side of the single-phase 100-115 V power cable to the L terminal and the neutral side to the N terminal.

Use a power supply capable of supplying the current capacity as shown below.

Model	Current capacity
UPK54□	Single-phase 100-115 V±15% 1.5 A or more
UPK56□, UPK59□	Single-phase 100-115 V±15% 5.5 A or more
UPK56□H, UPK59□H (high-speed type)	Single-phase 100-115 V±15% 8.0 A or more

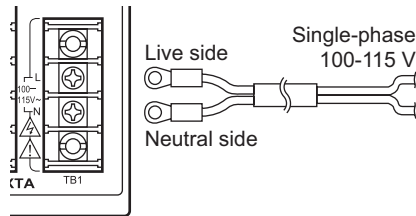

■ Single-phase 200-230 V

Connect the live side of the single-phase 200-230 V power cable to the L terminal and the neutral side to the N terminal.

Use a power supply capable of supplying single-phase 200–230 V^{+10%}_{-15%} at 3.5 A or greater.

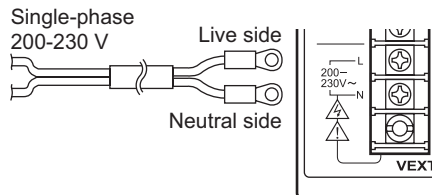

■ Terminal screw size and lead wire size for power connection

Use an insulated round crimp terminal for connection.

- Screw size: M3
- Tightening torque: 0.8 N·m (113 oz-in)
- Applicable minimum lead wire size: AWG18 (0.75 mm²) or more

Appropriate crimp terminal
[Unit: mm (in.)]

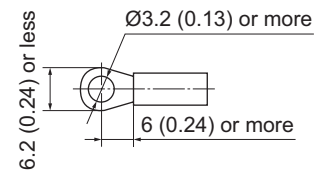

6.4 Connecting the motor

Connect the lead wires of motor cable (five wires: blue, red, orange, green and black) to the driver's motor connecting terminals. For the motor with an electromagnetic brake, also connect the electromagnetic brake's lead wires (two wires: red/white, black/white). Illustration shows the motor with electromagnetic brake.

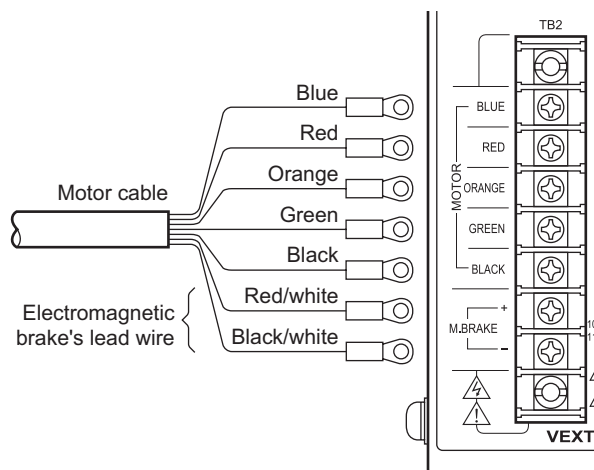

■ Terminal screw size and lead wire size for motor

Use an insulated round crimp terminal for connection.

- Screw size: M3
- Tightening torque: 0.8 N·m (113 oz-in)
- Applicable minimum lead wire size: AWG24 (0.2 mm²) or more

Appropriate crimp terminal
[Unit: mm (in.)]

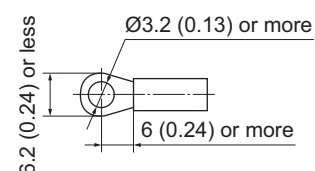

6.5 Grounding method

■ Grounding the motor

Install the motor to the grounded metal plate.

Use a grounding wire thicker than AWG18 (0.75 mm²).

When grounding, use a round terminal and affix it with a mounting screw over a crow washer.

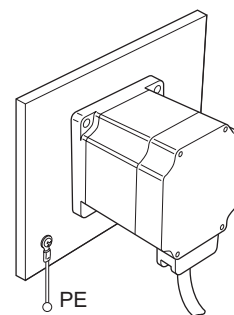

■ Grounding the driver

Be sure to ground the Protective Earth Terminal (screw size: M4) located on the driver side.

Use a grounding wire of AWG18 (0.75 mm²) or more in diameter.

Do not share the grounding wire with a welder or power equipment.

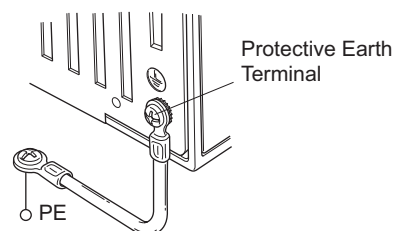

6.6 Connecting the input/output signals

■ Assembling the input/output signal connector

After soldering the input/output signal cable (AWG28: 0.08 mm² or more) to the connector (20 pins), assemble the connector with the case using the supplied screws. Use a shielded cable.

For the pin assignments, see “Connector pin functions” below.

We provide optional driver cable allowing one-touch connection with a driver, as well as connector-terminal block conversion unit. See p.39 for details.

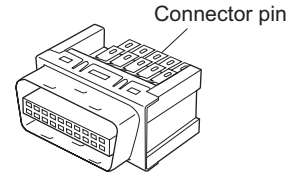

1. Place the connector with the input/output cable in the bottom connector case and screw the cable mounting bracket.
2. Place the screws so that their flat washers align with the indents in the connector case and the spring washers sit on the outside of the connector case.

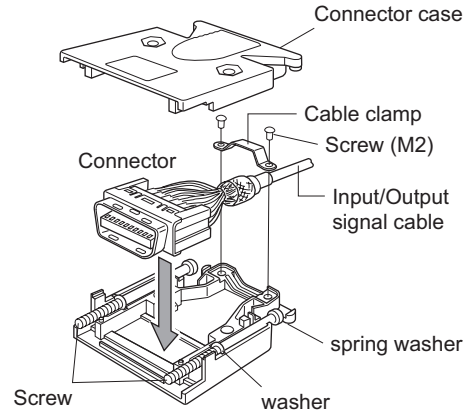

3. Attach the other connector case and clamp both connector case together with screws and nuts.
Tightening torque: 0.5 to 0.55 N·m (71 to 78 oz-in)

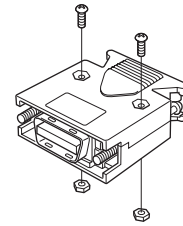

■ Connector pin functions

Pin No.	Signal	Description	Type
1	+CW (+PLS) ^{*1}	CW pulse (pulse)	Input
2	-CW (-PLS) ^{*1}		
3	+CCW (+DIR) ^{*1}	CCW pulse (rotation direction)	Input
4	-CCW (-DIR) ^{*1}		
5	-C.OFF	Output current off	Input
6	-M.B.FREE ^{*2}	Electromagnetic brake release	Input
7	-	No used	-
8	-	No used	-
9	-	No used	-
10	+COM	+ Common	Input
11	+TIM	Excitation timing	Output
12	+O.H.	Overheat	Output
13	-	No used	-
14	-	No used	-
15	-	No used	-
16	-	No used	-
17	-	No used	-
18	-	No used	-
19	-	No used	-
20	-COM	-Common	Output

*1 The descriptions in parentheses apply to the 1-pulse input mode.

*2 Motors with an electromagnetic brake only

• Connector pin assignments

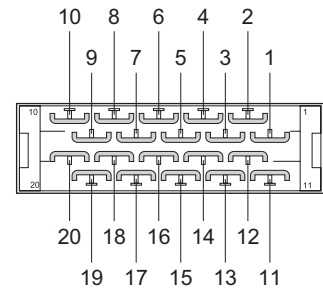

Viewed from the soldering side

■ Connecting the input/output signal connector

Insert the input/output signal connector into the CN1 on the driver, and tighten the screws.

Tightening torque: 0.3 to 0.35 N·m (42 to 49 oz-in)

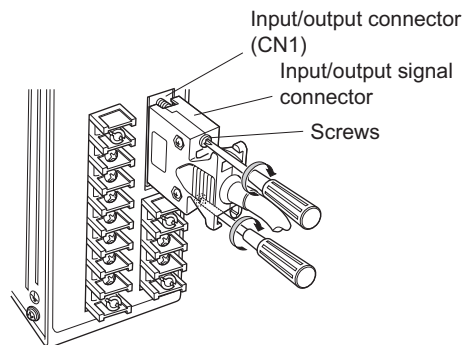

6.7 About input/output signals

■ Input signals

All input signals of the driver are photocoupler inputs. The signal state represents the “ON: Carrying current” or “OFF: Not carrying current” state of the internal photocoupler rather than the voltage level of the signal.

Note Use an input signal voltage of 5 VDC minimum and 24 VDC maximum. If the voltage exceeds 5 VDC, connect an external resistor to limit the input current to 10 to 20 mA.

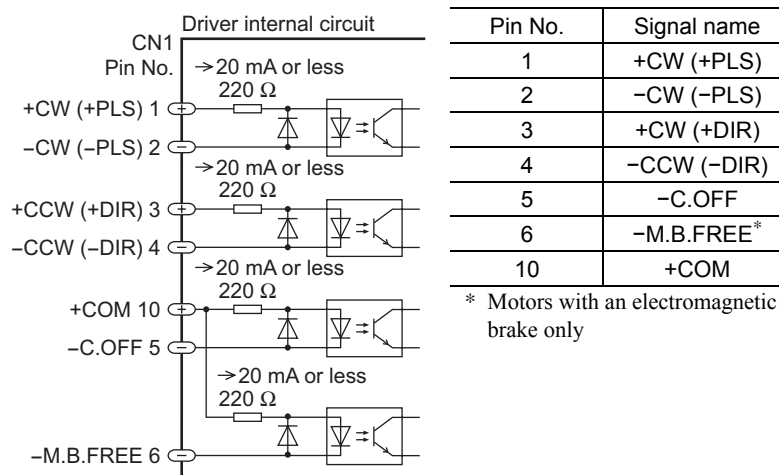

● CW (PLS) input, CCW (DIR) input

With this driver, either 2-pulse input mode or 1-pulse input mode may be selected in accordance with the controller used. Refer to p.32 for details on how to set the pulse input mode.

- Note**
- The minimum interval time needed for switching the direction of rotation will vary, depending on the operating speed and size of the load.
 - If no pulse is input, be sure to keep the photocoupler in OFF state. Do not input a CW pulse and CCW pulse simultaneously. If a pulse is input while the other photocoupler is in the ON state, the motor will not operate properly.
 - The direction of rotation is defined as the rotation direction of the motor shaft. The output shaft of the **TH** geared type motors with ratios of 20:1 and 30:1, as well as all ratios of the harmonic geared type motors, rotate in the opposite direction of the motor shaft.

2-pulse input mode (Factory setting)

Connect the CW pulse of the controller to pin No.2, and connect the CCW pulse to the pin No.4.

- When the CW input changes from ON to OFF, the motor will rotate one step in the CW direction.
- When the CCW input changes from ON to OFF, the motor will rotate one step in the CCW direction.

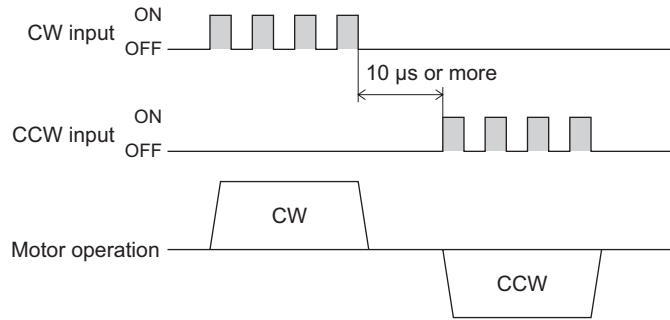

1-pulse input mode

Connect the pulse of the controller to the pin No.2, and connect the rotation direction output to the pin No.4.

- When the DIR input is ON, a fall of the PLS input from ON to OFF will rotate the motor one step in the CW direction.
- When the DIR input is OFF, a fall of the PLS input from ON to OFF will rotate the motor one step in the CCW direction.

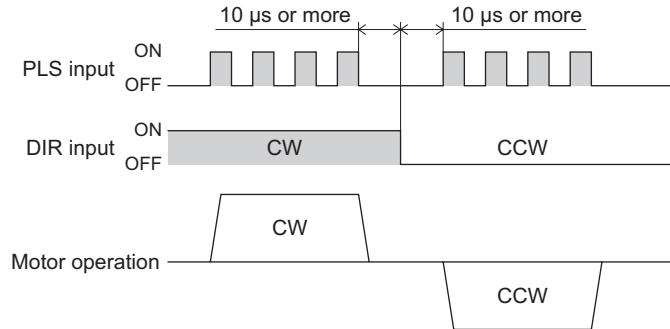

Pulse waveform and voltage

Use an input pulse signal with a waveform having a sharp rise and fall, as shown in the figure.

See below for the voltage between terminals.

ON: 4 to 5 V

OFF: 0 to 0.5 V

The voltage of pulse and rotating direction input to the CW input and CCW input shall be 5 VDC.

If the voltage exceeds 5 VDC, connect an external resistor to limit the input current to 10 to 20 mA.

$$R = \frac{V - 1.5}{15 \text{ mA}} - 220 \text{ } [\Omega] \quad R: \text{External resistor } (\Omega) \quad V: \text{Pulse voltage } (V)$$

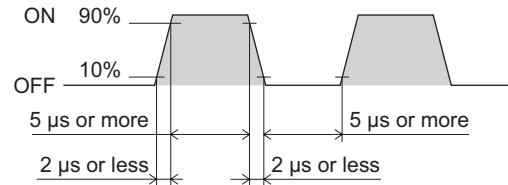

- C.OFF (output current off) input



Warning

Do not turn the C.OFF input to ON while the motor is operating. The motor will stop and lose its holding ability. As a result, the load will fall and may cause injury or damage to equipment.

Use this signal only when the motor's output shaft must be manually rotated for position adjustment.

- When the C.OFF input is turned ON, the driver will shut off the output current and the motor will lose its excitation holding torque. This, however, will allow you to adjust the load position manually.
- When the C.OFF input is turned OFF, the driver will turn the output current to ON again and the motor's excitation holding torque will be restored.

Note

- Normally, keep the C.OFF input in the OFF state or leave it disconnected.
- Do not input pulse signals immediately after switching the C.OFF signal to OFF, since doing so will affect the motor's starting characteristics. As a general rule, wait at least 100 ms before inputting a pulse signal.

- M.B.FREE (electromagnetic brake free) input [applicable only to motors with an electromagnetic brake]

Setting the electromagnetic brake function select switch to the OFF side allows control over releasing and holding the electromagnetic brake via the M.B.FREE input.

To operate the motor, be sure to release the electromagnetic brake by turning the M.B.FREE input to ON.

- Setting the M.B.FREE input to ON causes the driver to release the electromagnetic brake and allow motor operation.
- Setting the M.B.FREE input to OFF causes the driver to hold the electromagnetic brake.

Note An abrupt fluctuation in the load may cause the motor to misstep* during operation, start-up or standstill. The motor is not equipped with a function that triggers the electromagnetic brake upon the occurrence of a misstep. Therefore, when using the motor for an application involving vertical travel, perform sufficient test runs by conducting a test using the actual load to make sure that the motor is capable of driving the load without fail.

* Misstep: The term “misstep” refers to a condition in which the motor undergoes a rapid speed change or receives an excessive load and consequently stops or causes an offset in position due to its inability to turn synchronously with the pulse input. To hold the load in position while in the energy saver mode, verify that the load is within the range that can be held in position with the static friction torque of the electromagnetic brake.

Output signals

All output signals of the driver are photocoupler/open-collector outputs.

The signal state represents the “ON: Carrying current” or “OFF: Not carrying current” state of the internal photocoupler rather than the voltage level of the signal.

Note Use output signals with a power supply not exceeding 24 VDC and 10 mA. If these specifications are exceeded, the internal elements may be damaged. Check the specification of the connected equipment.

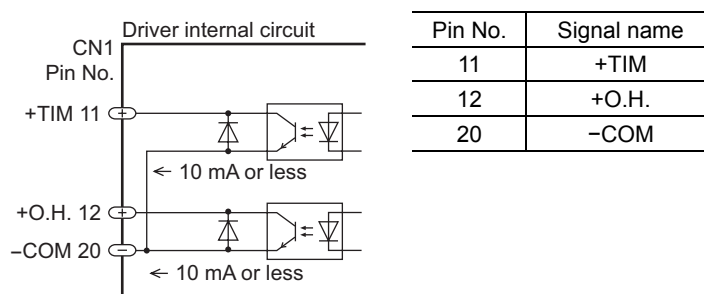

- Excitation timing output

The TIM output turns ON to light the TIM LED when the excitation state indicates the excitation home position (step 0). The motor’s excitation state is reset to the excitation home position when the driver’s power is turned on.

The TIM output turns ON each time the motor, synchronized with the pulse input, rotates 7.2°. When detecting the mechanical home position, the home position will be detected more accurately by configuring an AND circuit using the mechanical home position sensor and this TIM output, since it will reduce variance in the stopping position of the motor inside the mechanical home position’s sensing range.

Note When the TIM output is used, set the number of pulses or step angle so that the motor’s output shaft will stop at an integer multiple of 7.2°.

Example: 2-pulse input mode, 0.72° stepping

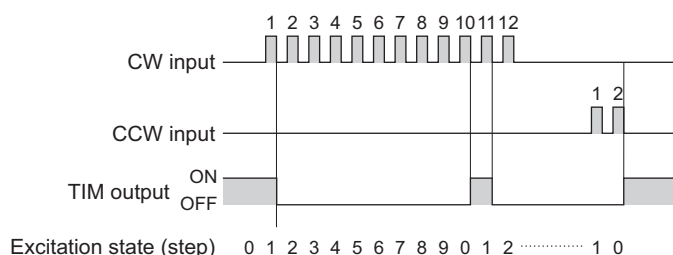

• O.H. output



Warning

If the automatic current off function is cancelled, the O.H. output should be detected upon actuation of the driver's overheat protection function in order to stop the motor. Failure to do so may result in fire.

The O.H. output remains OFF when the driver is operating normally, then turns ON to light the O.H. LED when overheat protection is triggered.

Check the operating conditions of the motor and the ventilation within the enclosure when overheat protection is triggered.

Stopping the motor operation upon actuation of the overheat protection function

Set the automatic current off function select switch to "A.C.O." (automatic current off.)

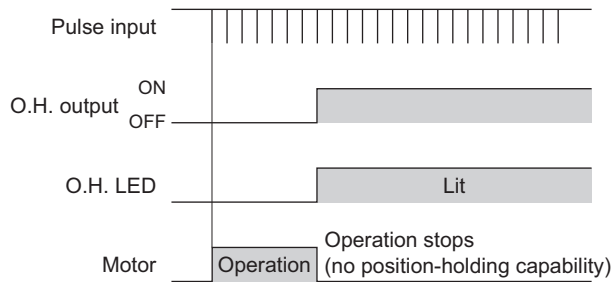

Allowing the motor operation to continue after actuation of the overheat protection function

Set the automatic current off function select switch to "OFF."

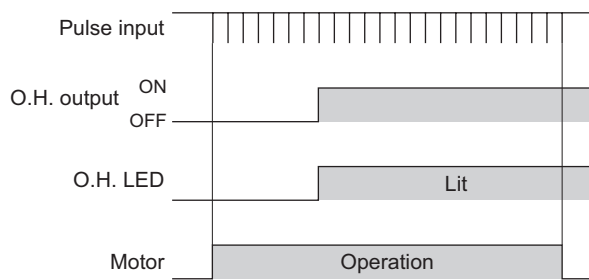

Canceling the O.H. output

The O.H. output will be cancelled when the power is cycled after the driver's heat sink temperature has dropped to 80° C (176 °F) or below.

Be sure to cycle the power after removing the cause that had actuated the overheat protection function. After the power was turned off, wait for at least 5 seconds before turning on the power again.

6.8 Timing chart

Operation condition of this timing chart is as follows.

- Pulse input mode: 2-pulse input mode
- Step angle: Full step
- Electromagnetic brake function select switch: M.B.F.

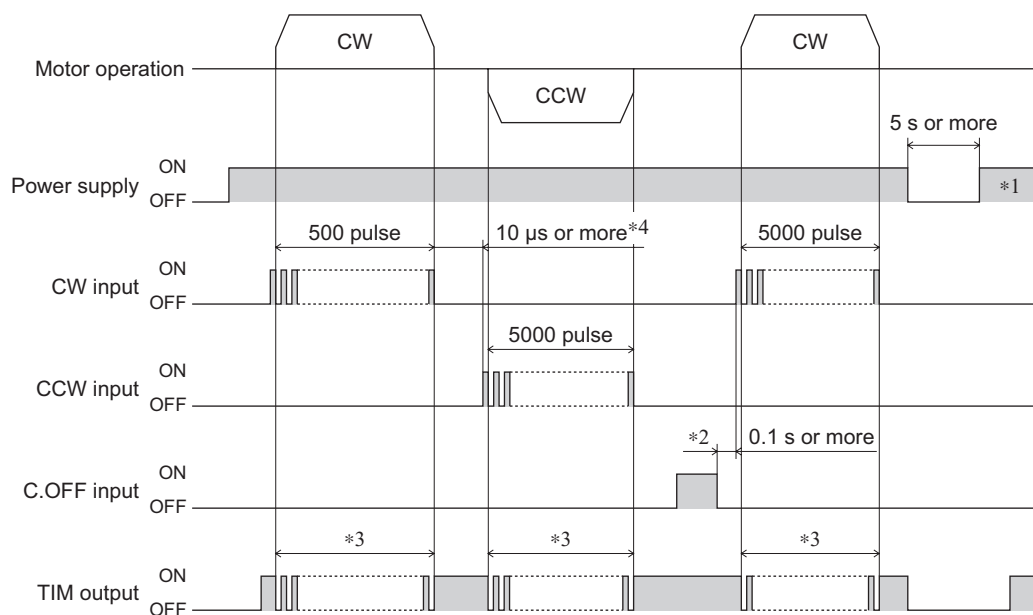

*1 After turning off the power, wait at least 5 seconds before turning the power back on.

*2 When the C.OFF input is turned to ON, the motor's current is turned off and the motor loses its holding ability.

*3 Signal is output once every 7.2° rotation of the motor output shaft.

*4 The minimum interval time needed for switching the direction of rotation will vary, depending on the operating speed and size of the load.

7 Setting

This section covers the switching and settings of driver functions.
Illustration shows the standard type with an electromagnetic brake.

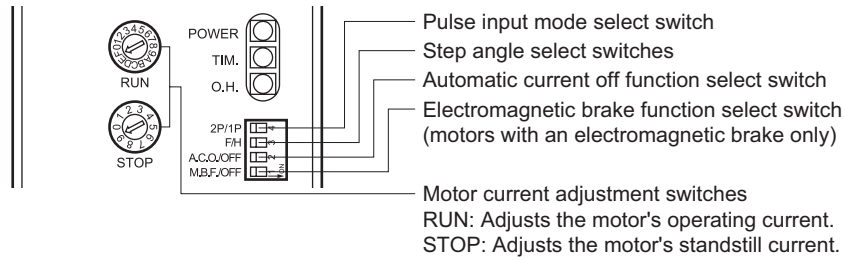

7.1 Step angle

Use the step angle select switches to select the step angle.
Factory settings: "F" (full step)

- Set the switch to the "F" side to select the full step mode (0.72°/step).
- Set the switch to the "H" side to select the half step mode (0.36°/step).

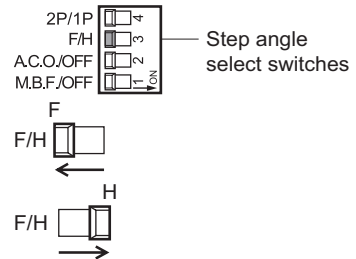

7.2 Motor currents

Use the motor current adjustment switches (RUN, STOP) to adjust the motor current.

Factory settings: RUN "F"
STOP "9"

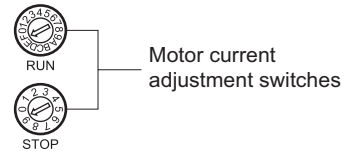

Use the motor's operating current adjustment switch "RUN" to adjust the motor's operating current.
The switch sets the operating current at 16 different levels between "0" and "F."

To adjust the current level for the motor in the standstill, use the motor's standstill current adjustment switch "STOP."

The switch sets the amount of reduction in motor current relative to the operating current at 10 different levels between "0" and "9." The motor current in the standstill will be the operating current multiplied by the set cutback rate.

To adjust the motor current, switch the RUN or STOP dial setting using a screwdriver.

The dial settings and corresponding levels of motor operating current and current cutback rates are as follows.

RUN

Dial setting	Operating current [A/phase]			
	UDK5107NW2 UDK5107NW2-M	UDK5114NW2 UDK5114NW2-M	UDK5128NW2 UDK5128NW2-M	UDK5214NW UDK5214NW-M
0	0.19	0.35	0.70	0.46
1	0.23	0.42	0.80	0.52
2	0.27	0.50	0.95	0.58
3	0.30	0.56	1.05	0.65
4	0.34	0.63	1.23	0.71
5	0.38	0.70	1.35	0.77
6	0.42	0.77	1.50	0.84
7	0.45	0.84	1.63	0.90
8	0.49	0.96	1.80	0.96
9	0.53	0.98	1.98	1.02
A	0.56	1.05	2.10	1.09
B	0.60	1.12	2.25	1.15
C	0.64	1.19	2.40	1.21
D	0.68	1.26	2.50	1.28
E	0.72	1.33	2.70	1.34
F	0.75	1.40	2.80	1.40

STOP

Dial setting	Current cutback rate [%]			
	UDK5107NW2 UDK5107NW2-M	UDK5114NW2 UDK5114NW2-M	UDK5128NW2 UDK5128NW2-M	UDK5214NW UDK5214NW-M
0	6	7	7	19
1	6	7	7	19
2	9	7	7	22
3	15	13	13	26
4	21	19	19	30
5	27	26	26	33
6	32	32	32	37
7	38	38	38	41
8	44	44	44	45
9	50	50	50	48

Note

- The maximum value of the motor's operating current is set as its rated current. Setting the motor's current slightly lower may have a favorable effect in terms of suppressing increases in motor temperature and reducing vibration, if the load is relatively small and there is extra torque.
- Excessively low motor's standstill current may cause a problem in starting the motor or holding the load in position. Do not reduce the stopped-state current any more than is necessary. The motor standstill current can be lowered to the applicable level specified below.

UDK5107NW2 UDK5107NW2-M	6% of the operating current
UDK5114NW2 UDK5114NW2-M UDK5128NW2 UDK5128NW2-M	7% of the operating current
UDK5214NW UDK5214NW-M	19% of the operating current

7.3 Pulse input mode

Select the pulse input mode in accordance with the controller used.

Factory setting: "2P" (2-pulse input mode)

- When the motor is to be controlled through the CW pulse and CCW pulse, set the switch to "2P."
- When the motor is to be controlled through the pulse and the rotating direction, set the switch to "1P."

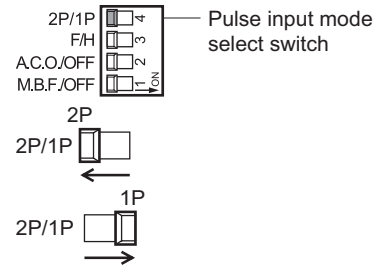

7.4 Automatic current off function



Warning

If the automatic current off function is cancelled, the O.H. output should be detected upon actuation of the driver's overheat protection function in order to stop the motor. Failure to do so may result in fire.

This function enables the user to select whether the motor is stopped or allowed to continue operating when the driver's overheat-protection function is triggered.

Factory setting: A.C.O. (motor is stopped.)

- To stop the motor when overheat protection is triggered, set the switch to "A.C.O."
- To keep the motor running even after overheat protection is triggered, set the switch to "OFF."

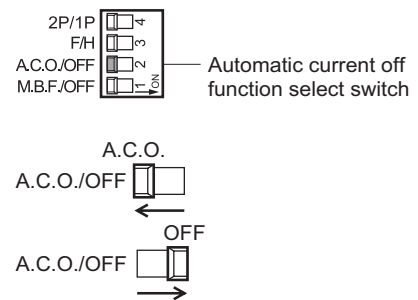

7.5 Electromagnetic brake function (motors with an electromagnetic brake only)

The electromagnetic brake serves to hold the position in the event the power is cut off. The electromagnetic brake, however, can also be actuated after the motor is stopped, if the motor will remain stopped for a prolonged period, in order to cut off the current and thereby suppress the heat generation while the motor is in its standstill state.

Set whether or not to hold the position using the electromagnetic brake for this purpose, other than when the power is cut off.

Factory setting: "M.B.F." (release the electromagnetic brake)

- To release the electromagnetic brake when the power is input, set the switch to the "M.B.F." side.
- To actuate the electromagnetic brake when the power is input, set the switch to the "OFF" side. You can use the M.B. FREE input to release or actuate the electromagnetic brake.

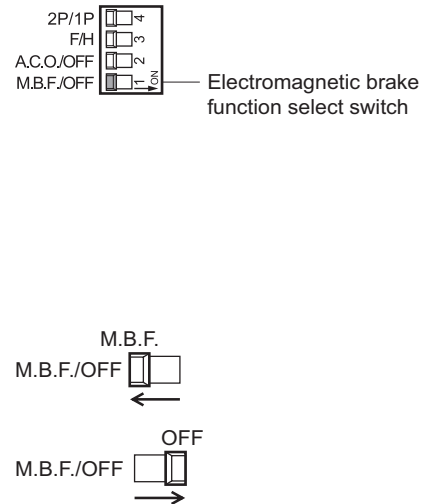

Note

Once the power is cut off, the electromagnetic brake will actuate to hold the motor output shaft in position.

■ Timing chart (When the electromagnetic brake function select switch is set to “OFF”)

- When the power supply is on

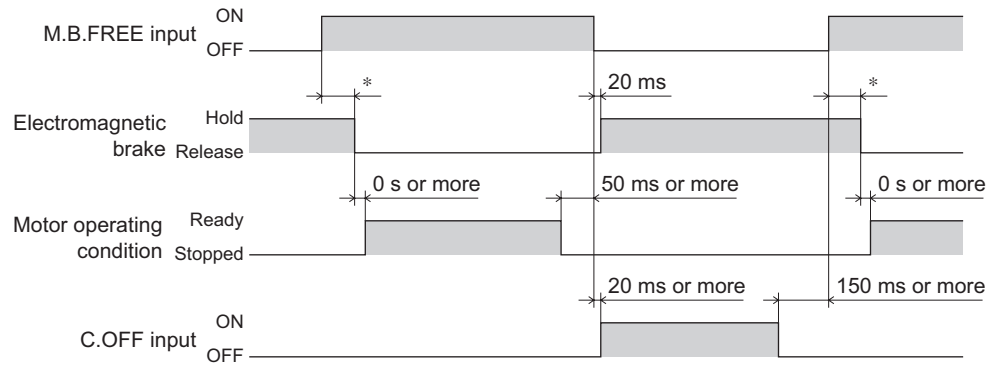

Refer to the table below for the electromagnetic brake release time (*).

Frame size [mm (in.)]	Brake release time (ms)
□42 (1.65), □60 (2.36)	30
□85 (3.35)	50

- To operate the motor, turn the M.B.FREE input to ON, thereby releasing the electromagnetic brake.
- Input the pulse signal after releasing the electromagnetic brake.
- Turn the M.B.FREE input to OFF to set the electromagnetic brake to hold after the motor stops. The output current will not be turned OFF.
- To turn OFF the output current when the motor stops, turn the C.OFF input to ON.

- When the power supply is off

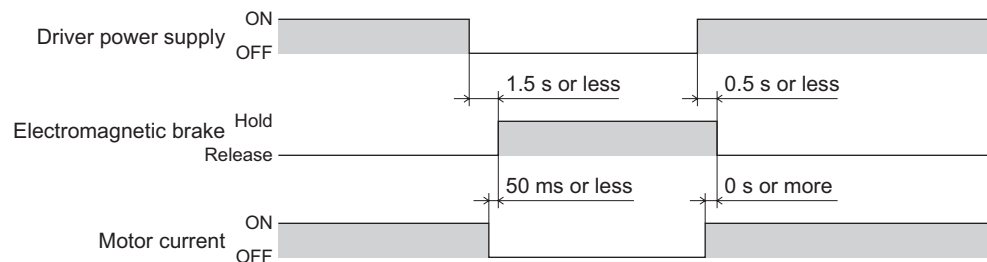

8 Overheat protection function

Overheat protection is triggered when the driver's internal temperature reaches approx. 80 °C (176 °F), upon which the O.H output is turned ON and the O.H. LED (red) turns on.



Warning

If the automatic current off function is cancelled, the O.H. output should be detected upon actuation of the driver's overheat protection function in order to stop the motor. Failure to do so may result in fire.

■ Stopping the motor operation

The automatic current off function select switch has been set to "A.C.O." before shipment.

When overheat protection is triggered, output current will be turned off and motor operation stopped regardless of the pulse input at the time.

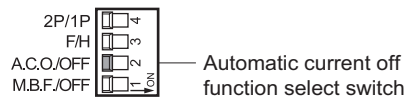

■ Allowing the motor operation to continue

If you wish to allow the motor operation to continue even after overheat protection is triggered, set the automatic current off function select switch to OFF. The output current will not be turned off and the motor will continue to operate.

At the completion of motor operation, shut off the driver's power promptly.

■ Canceling the O.H. output

The O.H. output will be cancelled when the power is cycled after the driver's heat sink temperature has dropped to 80° C (176 °F) or below.

Be sure to cycle the power after removing the cause that had actuated the overheat protection function. After the power was turned off, wait for at least 5 seconds before turning on the power again.

9 Inspection

It is recommended that periodic inspections be conducted for the items listed below after each operation of the motor. If an abnormal condition is noted, discontinue any use and contact your nearest office.

■ Inspection item

- Are any of the motor mounting screws loose?
- Are there any abnormal sounds from the motor's bearing section (ball bearings) or elsewhere?
- Is there any deviation between the centers of the motor's output shaft and load shaft?
- Do any of the motor cables have damage or stress, or is there any play at the section for connection with the driver?
- Check for a blocked opening of the driver case.
- Are any of the driver mounting screws or power-connection terminal screws loose?
- Are there any strange smells or appearances in the driver?

Note

The driver uses power device and semiconductor elements, so be extremely careful when handling them. Static electricity may damage the driver.

10 Troubleshooting and remedial actions

During motor operation, the motor or driver may fail to function properly due to incorrect speed setting or wiring. When the motor cannot be operated correctly, refer to the contents provided in this section and take appropriate action. If the problem persists, contact your nearest office.

Note | Certain items must be checked with the power on. Be careful not to touch the live connections.

Phenomenon	Possible cause	Remedial action
<ul style="list-style-type: none"> • The motor is not excited. • The motor's output shaft can be turned with hands. (The motor with an electromagnetic brake can be turned with the hands, once the brake is released.) 	Bad connection of the motor cable.	Check the connections between the motor and driver.
	Incorrect setting of the current. If the setting is too small, reduced motor torque results in unstable operation.	Return the motor current adjustment switches to the factory setting and check again. RUN: F STOP: 9
	C.OFF input is ON.	Turn the C.OFF input to OFF and confirm that the motor shaft is held in position.
	The driver's overheat protection is active. (The O.H. LED is lit.) The motor will not be held in position if the automatic current off function select switch is set to "A.C.O."	Shut off the driver's power and check the cause of the problem that had triggered overheat protection. Take appropriate action and turn on the power again.
The motor does not run.	Bad connection of the pulse input line. The TIM LED is not flashing.	<ul style="list-style-type: none"> • Check the connections of the controller and driver. • Check the pulse signal specifications (voltage and width.)
	In 2-pulse input mode, the CW and CCW inputs are both ON at the same time.	Input the pulse signal either to the CW or CCW side. Also, make sure the terminal with no input is set to OFF.
	In 1-pulse input mode, the pulse signal is connected to the DIR input.	Connect the pulse input signal to the PLS input.
The motor rotates in the direction opposite that which is specified.	In 2-pulse input mode, the CW and CCW pulses are connected in reverse.	Connect the CW pulse to the CW input and CCW pulse to CCW input.
	In 1-pulse input mode, the DIR input is set in reverse.	Set to ON to rotate the CW direction or OFF to the CCW direction.
Motor operation is unstable.	Bad connection of the motor cable.	Check the connections between the motor and driver.
	Incorrect setting of the current. If the setting is too small, reduced motor torque results in unstable operation.	Return the motor current adjustment switches to the factory setting and check again. RUN: F STOP: 9
	Bad connection of the pulse input line. The TIM LED is not flashing.	<ul style="list-style-type: none"> • Check the connections of the controller and driver. • Check the pulse signal specifications (voltage and width.)

Phenomenon	Possible cause	Remedial action
The motor missteps during acceleration or operation.	Misalignment of the motor's output shaft and load shaft.	Check the coupling of the motor output shaft and load shaft.
	Excessive load or large fluctuation in the load.	Check for a large fluctuation in the load during motor operation. If the problem does not occur after reducing the motor's operating speed, i.e., increasing the torque, a review of load conditions is required.
	The starting pulse speed is too high.	Reduce the starting pulse speed to a level at which starting becomes stable.
	The acceleration (deceleration) time is too short.	Increase the acceleration (deceleration) time to a level at which starting becomes stable.
	Noise is affecting operation.	Verify operation by using only the motor, driver and controller needed for operation. If noise is confirmed, take remedial actions such as isolating the noise source, performing wiring again, changing the signal cable to a shielded cable, and installing a ferrite core.
Vibration is large.	Misalignment of the motor's output shaft and load shaft.	Check the coupling of the motor output shaft and load shaft.
	Resonating motor	If vibration subsides at a different operating speed, the motor is resonating. Modify the set operating speed. With the double-shaft type, install an optional clean damper (sold separately) to reduce vibration more effectively.
	Small load	Reduce the operating current. If the motor's output torque is too large for the load, vibration will increase.
The overheat-protection function is active.	Inappropriate installation environment for the driver.	<ul style="list-style-type: none"> • Install the driver on a metal enclosure to promote heat dissipation. • Lower the ambient temperature to a range between 0 to +50 °C (+32 to +122 °F) by improving the ventilation or providing forced cooling of the driver.
	Continuous operation at an operating speed that increases the driver's input current.	Change the operating speed or reduce the operating time by referring to the driver's input current in the speed-torque characteristics in the catalog.
The electromagnetic brake does not hold.	M.B.FREE input is ON.	When the electromagnetic brake function select switch is set to "OFF," turn OFF the M.B.FREE input to set the electromagnetic brake to hold. When the electromagnetic brake function select switch is set to "M.B.F.," the electromagnetic brake will not hold unless the power to the driver is turned OFF.
	The power was turned on again within 5 seconds after turning off.	Wait for at least 5 seconds before turning on the power again. If the power is turned on within 5 seconds, the electromagnetic brake may not actuate.

11 Specifications

This section covers the main specifications of the 5-phase stepping motor unit **UPK-W** series.
Refer to the catalog for detailed specifications, torque characteristics and dimensions.

		Motor	Driver
Degree of protection		IP30	IP00
Operation environment	Ambient temperature	-10 to +50 °C (+14 to +122 °F) (non-freezing) Harmonic geared type: 0 to +40 °C (+32 to +104 °F) (non-freezing)	0 to +50 °C (+32 to +122 °F) (non-freezing)
	Humidity	85% or less (non-condensing)	
	Altitude	Up to 1000 m (3300 ft.) above sea level	
	Surrounding atmosphere	No corrosive gas, dust, water or oil	
Storage environment	Ambient temperature	-25 to +70 °C (-13 to +158 °F) (non-freezing) Harmonic geared type: -20 to +60 °C (-4 to +140 °F) (non-freezing)	-25 to +70 °C (-13 to +158 °F) (non-freezing)
	Humidity	85% or less (non-condensing)	
	Altitude	Up to 3000 m (10 000 ft.) above sea level	
	Surrounding atmosphere	No corrosive gas, dust, water or oil	
Shipping environment	Ambient temperature	-25 to +70 °C (-13 to +158 °F) (non-freezing) Harmonic geared type: -20 to +60 °C (-4 to +140 °F) (non-freezing)	-25 to +70 °C (-13 to +158 °F) (non-freezing)
	Humidity	85% or less (non-condensing)	
	Altitude	Up to 3000 m (10 000 ft.) above sea level	
	Surrounding atmosphere	No corrosive gas, dust, water or oil	

12 Option (sold separately)

■ Extension cable

These cables are used to extend the wiring length between the motor and driver. Can not used for motors with an electromagnetic brake.

Model	Length [m (ft.)]	Number of cores
CC05PK5	5 (16.4)	5
CC10PK5	10 (32.8)	
CC20PK5	20 (65.6)	

■ Driver cable

A shielded cable for driver control inputs/outputs (20 pins) offering excellent noise resistance. It comes with a half-pitch connector allowing one-touch connection to a driver.

Model	Length [m (ft.)]
CC20D1-1	1 (3.3)
CC20D2-1	2 (6.6)

■ Connector-terminal block conversion unit

Use this cable to connect the driver to a host controller via the terminal block. [Cable length: 1 m (3.3 ft.)]

Model: **CC20T1**

- Unauthorized reproduction or copying of all or part of this manual is prohibited.
If a new copy is required to replace an original manual that has been damaged or lost, please contact your nearest Oriental Motor branch or sales office.
- Oriental Motor shall not be liable whatsoever for any problems relating to industrial property rights arising from use of any information, circuit, equipment or device provided or referenced in this manual.
- Characteristics, specifications and dimensions are subject to change without notice.
- While we make every effort to offer accurate information in the manual, we welcome your input. Should you find unclear descriptions, errors or omissions, please contact the nearest office.
- **Orientalmotor** is a registered trademark or trademark of Oriental Motor Co., Ltd., in Japan and other countries.
Other product names and company names mentioned in this manual may be registered trademarks or trademarks of their respective companies and are hereby acknowledged. The third-party products mentioned in this manual are recommended products, and references to their names shall not be construed as any form of performance guarantee. Oriental Motor is not liable whatsoever for the performance of these third-party products.

© Copyright ORIENTAL MOTOR CO., LTD. 2010

- Please contact your nearest Oriental Motor office for further information.

ORIENTAL MOTOR U.S.A. CORP.
Technical Support Tel:(800)468-3982
8:30 A.M. to 5:00 P.M., P.S.T. (M-F)
7:30 A.M. to 5:00 P.M., C.S.T. (M-F)
E-mail: techsupport@orientalmotor.com
www.orientalmotor.com

ORIENTAL MOTOR (EUROPA) GmbH
Headquarters and Düsseldorf Office
Tel:0211-5206700 Fax:0211-52067099
Munich Office
Tel:089-3 18 12 25-00 Fax:089-3 18 12 25-25
Hamburg Office
Tel:040-76910443 Fax:040-76910445

ORIENTAL MOTOR (UK) LTD.
Tel:01256-347090 Fax:01256-347099

ORIENTAL MOTOR (FRANCE) SARL
Tel:01 47 86 97 50 Fax:01 47 82 45 16

ORIENTAL MOTOR ITALIA s.r.l.
Tel:02-93906346 Fax:02-93906348

TAIWAN ORIENTAL MOTOR CO.,LTD.
Tel:(02)8228-0707 Fax:(02)8228-0708

SINGAPORE ORIENTAL MOTOR PTE LTD
Tel:(6745)7344 Fax:(6745)9405

ORIENTAL MOTOR (MALAYSIA) SDN. BHD.
Tel:(03)22875778 Fax:(03)22875528

ORIENTAL MOTOR (THAILAND) CO.,LTD.
Tel:66-2-254-6113 Fax:66-2-254-6114

INA ORIENTAL MOTOR CO.,LTD.

KOREA
Tel:(032)822-2042~3 Fax:(032)819-8745

ORIENTAL MOTOR CO.,LTD.
Headquarters Tokyo, Japan
Tel:(03)3835-0684 Fax:(03)3835-1890