

Brushless Motor

BLV series R type Driver

CANopen communication profile



1	General Information.....	8
1.1	About this manual	8
1.2	Object description	9
2	Installation and Setup	10
2.1	Installation and connection	10
2.2	Connection of termination resistor	11
2.3	Setting the Bitrate and Node-ID	11
3	Communication specifications	12
3.1	CANopen device model.....	12
3.2	General description of CAN.....	13
3.3	Communication Object Identifier (COB-ID).....	14
3.4	Endian format.....	15
4	Communication Objects	16
4.1	Network Management (NMT)	16
4.2	NMT Error Control	18
4.2.1	Node Guarding	18
4.2.2	Heartbeat.....	20
4.3	NMT boot-up	21
4.4	Synchronization object (SYNC)	21
4.5	Emergency object (EMCY)	22
4.6	Service data object (SDO)	24
4.6.1	SDO download initiate.....	26
4.6.2	SDO download segment	27
4.6.3	SDO upload initiate	28
4.6.4	SDO upload segment	29
4.6.5	SDO abort transfer.....	30
4.7	Process data object (PDO)	31
4.7.1	PDO mapping.....	32
4.7.2	Transmission type.....	32
5	Device control	33
5.1	Status Machine	33
6	Status Machine control commands.....	34
6.1	Bits in Statusword (6041h).....	34
6.2	Transitions of the status machine	35
6.3	Related Objects.....	35
7	Operation mode.....	36
7.1	Modes of Operation	36
7.1.1	General Information.....	36
7.1.2	Related Objects.....	36
7.2	Profile Velocity Mode (pv)	37

7.2.1	General Information.....	37
7.2.2	Related Objects.....	38
7.2.3	Controlword of the Profile Velocity Mode.....	38
7.2.4	Statusword of the Profile Velocity Mode	39
7.2.5	Operation in the Profile Velocity Mode.....	40
7.3	Profile Position Mode (pp)	41
7.3.1	General Information.....	41
7.3.2	Related Objects.....	42
7.3.3	Controlword of the Profile Position Mode	43
7.3.4	Statusword of the Profile Position Mode.....	44
7.3.5	Operation in the Profile Position Mode	45
7.3.6	Positioning option code (60F2h).....	46
7.4	Homing Mode (hm).....	47
7.4.1	General Information.....	47
7.4.2	Related Objects.....	47
7.4.3	Controlword of the Homing Mode.....	48
7.4.4	Statusword of the Homing Mode	49
7.4.5	Homing method.....	50
7.5	Touch probe functionality	54
7.5.1	General Information.....	54
7.5.2	Related Objects.....	54
7.5.3	Example of Execution Procedure for a Touch Probe	55
8	Object Dictionary	56
8.1	Communication Objects	56
	1000h: Device Type	56
	1001h: Error register	56
	1003h: Pre-defined error field	57
	1005h: COB-ID SYNC message	58
	1006h: Communication cycle period	59
	1008h: Manufacturer device name	59
	1009h: Manufacturer hardware version	59
	100Ah: Manufacturer software version	59
	100Ch: Guard time	59
	100Dh: Life time factor	59
	1010h: Store parameters.....	60
	1011h: Restore default parameters	61
	1014h: COB-ID EMCY	62
	1016h: Consumer heartbeat time.....	62
	1017h: Producer heartbeat time	63
	1018h: Identity object.....	63
	1200h: SDO server parameter	63
	1400h: 1st RPDO communication parameter.....	64

1401h: 2nd RPDO communication parameter	65
1402h: 3rd RPDO communication parameter	66
1403h: 4nd RPDO communication parameter	67
1600h: 1st RPDO mapping parameter	68
1601h: 2nd RPDO mapping parameter	69
1602h: 3rd RPDO mapping parameter.....	70
1603h: 4th RPDO mapping parameter	71
1800h: 1st TPDO communication parameter	72
1801h: 2nd TPDO communication parameter	74
1802h: 3rd TPDO communication parameter	76
1803h: 4th TPDO communication parameter	78
1A00h: 1st TPDO mapping parameter	80
1A01h: 2nd TPDO mapping parameter	81
1A02h: 3rd TPDO mapping parameter	82
1A03h: 4th TPDO mapping parameter	83
8.2 Manufacturer Specific Objects.....	84
402Ch: Direct data operation operation data number	84
402Dh: Direct data operation operation type.....	84
402Eh: Direct data operation position	84
402Fh: Direct data operation operating velocity	84
4030h: Direct data operation acceleration rate	84
4031h: Direct data operation deceleration rate	84
4032h: Direct data operation torque limiting value	84
4033h: Direct data operation trigger.....	85
4034h: Direct data operation forwarding destination	85
403Ah: Driver input command (2nd).....	85
403Ch: Driver input command (automatic OFF)	85
403Dh: NET selection data number	85
403Eh: Driver input command.....	85
403Fh: Driver output status	85
404Bh: Target position (User-defined position unit).....	85
404Ch: Demand position (User-defined position unit).....	86
404Dh: Actual position (User-defined position unit).....	86
404Eh: Target velocity (User-defined velocity unit).....	86
404Fh: Demand velocity (User-defined velocity unit).....	86
4050h: Actual velocity (User-defined velocity unit)	86
4056h: Present communication error.....	86
406Bh: Torque monitor	86
406Ch: Load factor monitor	86
406Dh: Cumulative load monitor	87
4070h: Next data number.....	87
4071h: Loop origin data number	87
4072h: Loop count	87

4073h: Position deviation	87
4075h: Speed deviation.....	87
407Ah: Tripmeter 1	87
407Bh: Present information	87
407Ch: Driver temperature.....	88
407Dh: Motor temperature	88
407Eh: Odometer.....	88
407Fh: Tripmeter 0.....	88
409Bh: Main power supply current	88
409Ch: Power consumption.....	88
409Dh: Energy consumption.....	88
409Eh: User energy consumption.....	88
409Fh: Total energy consumption	89
40A1h: Total uptime.....	89
40A2h: Number of boots.....	89
40A3h: Inverter voltage	89
40A4h: Main power supply voltage	89
40A9h: Continuous uptime	89
40AAh: RS-485 communication reception byte counter.....	89
40ABh: RS-485 communication transmission byte counter.....	89
40C0h: Alarm reset	89
40C2h: Clear alarm history	90
40C5h: P-PRESET execution	90
40C6h: Configuration	90
40CDh: Clear latch information	90
40CEh: Clear sequence history.....	90
40D0h: Clear ETO	90
40D1h: ZSG-PRESET	90
40D2h: Clear ZSG-PRESET	90
40D3h: Clear information.....	90
40D6h: Clear user energy consumption.....	91
40D7h: Clear tripmeter 0.....	91
40D8h: Clear tripmeter 1	91
4148h: Permission of absolute positioning without setting absolute coordinates	91
415Fh: JOG/HOME Torque limit value	91
4160h: (HOME) Homing mode.....	91
4163h: (HOME) Starting velocity	91
4169h: (HOME) Backward steps in 2 sensor homeseeking.....	91
4186h: Stopping timeout at alarm generation	92
41CAh: WRAP setting	92
4735h: Custom stopping rate.....	92
4736h: Custom stopping time	92

8.3	Device Profile Objects	93
	603Fh: Error code	93
	6040h: Controlword	93
	6041h: Statusword.....	94
	605Ah: Quick stop option code	95
	605Bh: Shutdown option code	95
	605Ch: Disable operation option code	95
	605Dh: Halt option code	95
	605Eh: Fault reaction option code.....	96
	6060h: Modes of operation	96
	6061h: Modes of operation display.....	96
	6062h: Position demand value	96
	6064h: Position actual value	96
	6065h: Following error window	96
	6067h: Position window	97
	606Bh: Velocity demand value.....	97
	606Ch: Velocity actual value	97
	606Dh: Velocity window.....	97
	606Fh: Velocity threshold	97
	6072h: Max torque	97
	6077h: Torque actual value	97
	607Ah: Target position	98
	607Bh: Position range limit	98
	607Ch: Home offset	98
	607Dh: Software position limit	99
	6081h: Profile velocity.....	99
	6082h: End velocity.....	99
	6083h: Profile acceleration	99
	6084h: Profile deceleration	100
	6085h: Quick stop deceleration.....	100
	608Fh: Position encoder resolution	100
	6091h: Gear ratio.....	100
	6098h: Homing method.....	101
	6099h: Homing speeds.....	101
	609Ah: Homing acceleration	101
	60A8h: SI unit position.....	102
	60A9h: SI unit velocity.....	103
	60B8h: Touch probe function	104
	60B9h: Touch probe status	105
	60BAh: Touch probe 1 positive edge.....	105
	60BBh: Touch probe 1 negative edge.....	105
	60BCh: Touch probe 2 positive edge	105
	60BDh: Touch probe 2 negative edge	105

60D5h: Touch probe 1 positive edge counter	106
60D6h: Touch probe 1 negative edge counter	106
60D7h: Touch probe 2 positive edge counter	106
60D8h: Touch probe 2 negative edge counter	106
60E3h: Supported homing methods.....	107
60F2h: Positioning option code	108
60F4h: Following error actual value.....	109
60FDh: Digital inputs.....	109
60FEh: Digital outputs.....	110
60FFh: Target velocity (pv).....	110
6502h: Supported drive modes.....	111
67FEh: Version number.....	111
67FFh: Single device type.....	112
9 Appendix.....	113
9.1 Object list.....	113
9.2 Specifications	124

1 General Information

1.1 About this manual

This manual describes the setup, range of functions and software protocol of the **BLVD-KRD** brushless motor driver with the CANopen communication profile.

The installation and setup of the driver, as well as all standard functions, are described in the corresponding product manuals.

Title	Publisher	Manual number	
		Japanese	English
BLV Series R Type OPERATING MANUAL Installation and Connection Edition	Orientalmotor	HP-5139	HP-5140
BLV Series R Type OPERATING MANUAL Function Edition	Orientalmotor	HP-5141	HP-5142

Operating manuals are not included with the product. Download them from Oriental Motor Website Download Page or contact your nearest Oriental Motor sales office.

Additional documentation:

Title	Publisher
CiA documents	CiA.e.V.
ISO 11898: Controller Area Network (CAN) for high-speed communication	-

This manual is intended for the following qualified personnel:

Wiring: Professionally qualified electrical technicians

Programming: Software developers, project-planners

1.2 Object description

Notation	Description																								
Index	16-bit address to access information in the CANopen object dictionary.																								
Sub-index	For array and records the address is extended by an 8-bit sub-index.																								
Data type	<p>The following table lists the data types and ranges that are used in this manual.</p> <table border="1"> <thead> <tr> <th>Code</th> <th>Data Type</th> <th>Range</th> </tr> </thead> <tbody> <tr> <td>INT8</td> <td>Signed 8-bit integer (INTEGER8)</td> <td>-128 to 127</td> </tr> <tr> <td>INT16</td> <td>Signed 16-bit integer (INTEGER16)</td> <td>-32,768 to 32,767</td> </tr> <tr> <td>INT32</td> <td>Signed 32-bit integer (INTEGER32)</td> <td>-2,147,483,648 to 2,147,483,627</td> </tr> <tr> <td>UINT8</td> <td>Unsigned 8-bit integer (UNSIGNED8)</td> <td>0 to 255</td> </tr> <tr> <td>UINT16</td> <td>Unsigned 16-bit integer (UNSIGNED16)</td> <td>0 to 65,535</td> </tr> <tr> <td>UINT32</td> <td>Unsigned 32-bit integer (UNSIGNED32)</td> <td>0 to 4,294,967,295</td> </tr> <tr> <td>STRING</td> <td>Character string (Visible String)</td> <td>Same UINT8</td> </tr> </tbody> </table>	Code	Data Type	Range	INT8	Signed 8-bit integer (INTEGER8)	-128 to 127	INT16	Signed 16-bit integer (INTEGER16)	-32,768 to 32,767	INT32	Signed 32-bit integer (INTEGER32)	-2,147,483,648 to 2,147,483,627	UINT8	Unsigned 8-bit integer (UNSIGNED8)	0 to 255	UINT16	Unsigned 16-bit integer (UNSIGNED16)	0 to 65,535	UINT32	Unsigned 32-bit integer (UNSIGNED32)	0 to 4,294,967,295	STRING	Character string (Visible String)	Same UINT8
Code	Data Type	Range																							
INT8	Signed 8-bit integer (INTEGER8)	-128 to 127																							
INT16	Signed 16-bit integer (INTEGER16)	-32,768 to 32,767																							
INT32	Signed 32-bit integer (INTEGER32)	-2,147,483,648 to 2,147,483,627																							
UINT8	Unsigned 8-bit integer (UNSIGNED8)	0 to 255																							
UINT16	Unsigned 16-bit integer (UNSIGNED16)	0 to 65,535																							
UINT32	Unsigned 32-bit integer (UNSIGNED32)	0 to 4,294,967,295																							
STRING	Character string (Visible String)	Same UINT8																							
Access	<p>Access method of objects.</p> <ul style="list-style-type: none"> • rw: Read and write of values are possible. • ro: Only read of values is possible. • rww: Read/write on process output • c: Read only, value will not change 																								
PDO	<p>Indicates whether the PDO mapping of objects is possible.</p> <ul style="list-style-type: none"> • Yes: Mapping to PDO is possible. • No: Mapping to PDO is not possible. 																								
Unit	<p>The following table lists the data units and notations that are used in this manual.</p> <table border="1"> <thead> <tr> <th>Notation</th> <th>Description</th> </tr> </thead> <tbody> <tr> <td>Pos. unit</td> <td>You can define the position unit. Default: step</td> </tr> <tr> <td>Vel. unit</td> <td>You can define the velocity unit. Default: r/min</td> </tr> <tr> <td>Acc. unit</td> <td>Velocity unit per second (Vel. unit / s) Default: (r/min) / s</td> </tr> <tr> <td>Acc. unit (MS)</td> <td>Velocity unit per second (Vel. unit / s) or ms Default: ms According to "User-defined acceleration/deceleration unit setting" parameter.</td> </tr> </tbody> </table> <p>Refer to the following for details on the units. - OPERATING MANUAL BLV Series R Type Function Edition</p>	Notation	Description	Pos. unit	You can define the position unit. Default: step	Vel. unit	You can define the velocity unit. Default: r/min	Acc. unit	Velocity unit per second (Vel. unit / s) Default: (r/min) / s	Acc. unit (MS)	Velocity unit per second (Vel. unit / s) or ms Default: ms According to "User-defined acceleration/deceleration unit setting" parameter.														
Notation	Description																								
Pos. unit	You can define the position unit. Default: step																								
Vel. unit	You can define the velocity unit. Default: r/min																								
Acc. unit	Velocity unit per second (Vel. unit / s) Default: (r/min) / s																								
Acc. unit (MS)	Velocity unit per second (Vel. unit / s) or ms Default: ms According to "User-defined acceleration/deceleration unit setting" parameter.																								
Save	<p>Indicates whether data is saved in the non-volatile memory when the batch non-volatile memory write was executed.</p> <ul style="list-style-type: none"> • Yes: Saved in the non-volatile memory. • No : Not saved in the non-volatile memory. 																								

2 Installation and Setup

Setup the driver as described in the operation manuals for **BLV Series R Type**.
 Observe all safety instructions in the installation instructions that belong to the driver.
 Follow all the notes on mounting position, ambient conditions, wiring, and fusing.

Refer to the following for details on the installation and setup.
 - **BLV Series R Type OPERATING MANUAL Installation and Connection Edition**

2.1 Installation and connection

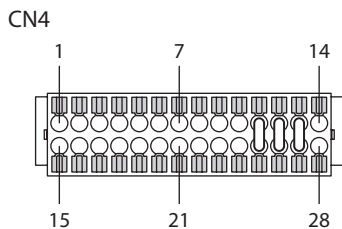
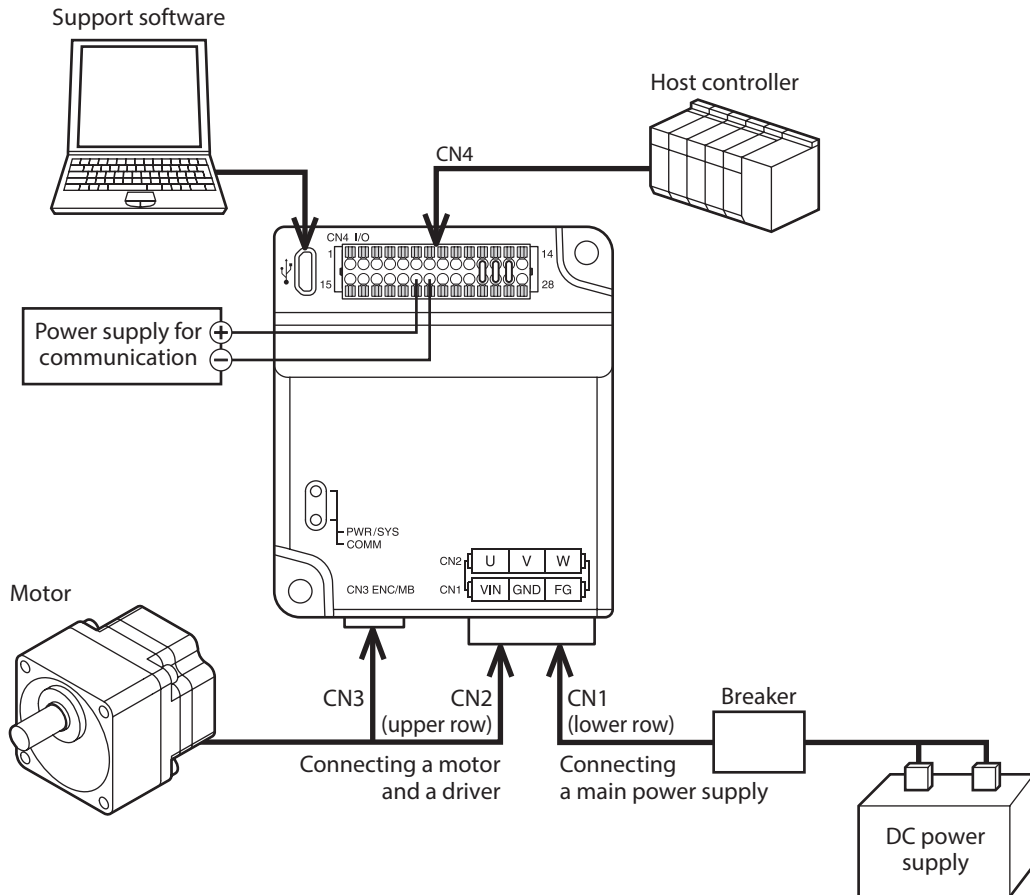

Pin No.	Signal name	Description
5	CAN_L	CAN Low
6	CAN_H	CAN High
7	CAN_GND	Ground for CAN communication
20	NET-VIN	Power supply for communication
21	NET-GND	Ground for power supply communication

2.2 Connection of termination resistor

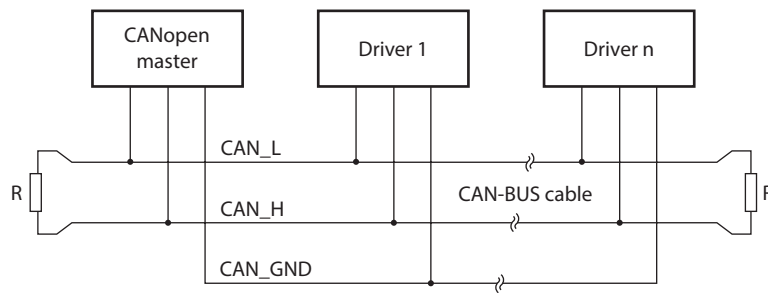

R: Termination resistor

Connect the termination resistor (120 Ω , 1/4 W or more) on both ends of a bus. Termination resistors are not included with the product.

2.3 Setting the Bitrates and Node-ID

● Setting the Node-ID

The Node-ID can be set in two different ways:

- By using the support software
- By using the ID-SEL input

Possible Node-ID: 1 to 127

Refer to the following for details on the ID-SEL input.

- **BLV Series R** Type OPERATING MANUAL Function Edition

● Setting the Bitrates

The Node-ID can be set following way:

- By using the support software

Possible Bitrate: 1000, 800, 500 (default), 250, 125, 50, 20, and 10 kbps

Bus length

Bitrate [kbit/s]	Maximum bus length [m]
1,000	25
800	50
500 (default)	100
250	250
125	500
50	1,000
20	2,500
10	5,000

3 Communication specifications

3.1 CANopen device model

A CANopen device is structured like the following.

- Communication
This function unit provides the communication objects and the appropriate functionality to transport data items via the underlying network structure.
- Object dictionary
The object dictionary is a collection of all the data items which have an influence on the behavior of the application objects, the communication objects and the state machine used on this device.
- Application
The application comprises the functionality of the device with respect to the interaction with the process environment.

Thus the object dictionary serves as an interface between the communication and the application.
A device profile is a description of a device's application in terms of the individual data contained in the object dictionary.

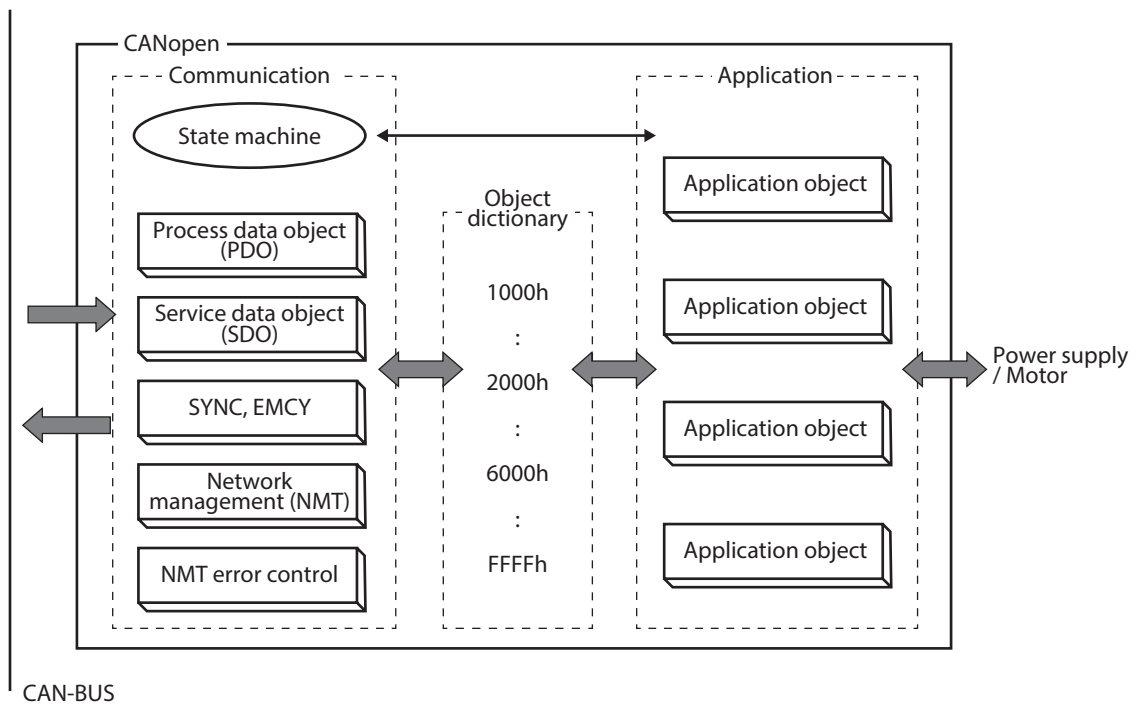

3.2 General description of CAN

The transmission method that is used here is defined in ISO 11898 (Controller Area Network CAN for high-speed communication).

Physical Layer/Data Link Layer that is implemented in all CAN modules provides, amongst other things, the requirements for data.

Data transport or data request is made by means of a data telegram (Data Frame) with up to 8 bytes of user data, or by a data request telegram (Remote Frame).

Communication Objects are labeled by an 11 bit Identifier (COB-ID) that also determines the priority of Objects.

Application Layer was developed, to decouple the application from the communication.

The service elements that are provided by the Application Layer make it possible to implement an application that is spread across the network. These service elements are described in the CAN Application Layer (CAL) for Industrial Applications.

The communication profile CANopen and the drive profile are mounted on the CAL.

The basic structure of a Communication Object is shown in the following.

SOM	COB-ID	RTR	CTRL	DATA	CRC	ACK	EOM
-----	--------	-----	------	------	-----	-----	-----

Notation	Description
SOM	Start of message (1 bit)
COB-ID	Communication object identifier (11 bits)
RTR	Remote transmission request (1 bit)
CTRL	Control field (e.g. Data length code) (6 bit)
DATA	Data field (0 to 8 bytes)
CRC	Cyclic redundancy check (15 bits) and CRC delimiter (1 bit)
ACK	Acknowledge slot (1 bit) and acknowledge delimiter (1 bit)
EOM	End of message (7 bit)

3.3 Communication Object Identifier (COB-ID)

The following diagram shows the layout of the communication object Identifier (COB-ID). The Function Code defines the interpretation and priority of the particular Object.

- **Data Description of COB-ID**

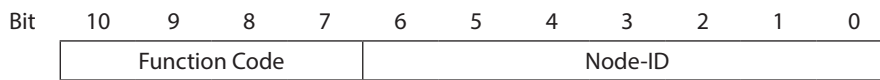

The priority is higher when the value is lower toward zero.

Thus the highest priority has the function code of zero. Higher priority message takes precedence on the CAN bus and the lower one will have to wait. The arbitration of the CAN bus is done at the CAN hardware level, thus ensuring that the highest priority message is transmitted first.

The following table shows the COB-ID on the driver.

Communication object (COB)	Description	Function code	Node-ID	Resulting COB-ID	Related objects
NMT	Network Management (broadcast)	0000b	0000000b	0 (000h)	-
SYNC	Synchronization message (broadcast)	0001b	0000000b	128 (080h)	1005h 1006h
EMCY	Emergency messages	0001b	Node-ID	128 (080h) + Node-ID	1014h
TPDO1	Transmit Process Data Object 1	0011b	Node-ID	384 (180h) + Node-ID	1800h
RPDO1	Receive Process Data Object 1	0100b	Node-ID	512 (200h) + Node-ID	1400h
TPDO2	Transmit Process Data Object 2	0101b	Node-ID	640 (280h) + Node-ID	1801h
RPDO2	Receive Process Data Object 2	0110b	Node-ID	768 (300h) + Node-ID	1401h
TPDO3	Transmit Process Data Object 3	0111b	Node-ID	896 (380h) + Node-ID	1802h
RPDO3	Receive Process Data Object 3	1000b	Node-ID	1024 (400h) + Node-ID	1402h
TPDO4	Transmit Process Data Object 4	1001b	Node-ID	1152 (480h) + Node-ID	1803h
RPDO4	Receive Process Data Object 4	1010b	Node-ID	1280 (500h) + Node-ID	1403h
TSDO	Transmit Service Data Objects	1011b	Node-ID	1408 (580h) + Node-ID	1200h
RSDO	Receive Service Data Objects	1100b	Node-ID	1536 (600h) + Node-ID	1200h
NMT error control	Network management error control	1110b	Node-ID	1792 (700h) + Node-ID	100Ch 100Dh 1016h 1017h

Note: NMT Error Control includes Node Guarding and Heartbeat.

- **Restricted COB-IDs**

Any COB-ID listed in the following table is of restricted use. Such a restricted COB-ID is not used as a COB-ID by any configurable communication object, neither for SYNC, EMCY, PDO, and SDO.

COB-ID	Used by COB
0 (000h)	NMT
1 (001h) to 127 (07Fh)	Reserved
257 (101h) to 384 (180h)	Reserved
1409 (581h) to 1535 (5FFh)	Default TSDO
1537 (601h) to 1663 (67Fh)	Default RSDO
1760 (6E0h) to 1791 (6FFh)	Reserved
1793 (701h) to 1919 (77Fh)	NMT Error Control
2020 (780h) to 2047 (7FFh)	Reserved

3.4 Endian format

CANopen uses Little Endian format. For numerical data greater than 1 byte, the least significant byte (LSB) is stored in the lowest order of the memory. When sending data, the LSB is sent first.

Example:

A 32 bit number has the value of 0x00112233. The 4 bytes data when assembled into the data field would look like the following.

Byte	0	1	2	3	4	5	6	7
	33h	22h	11h	00h	xx	xx	xx	xx

4 Communication Objects

4.1 Network Management (NMT)

The network management follows a master-slave structure. NMT requires a CANopen device in the network that performs the role of the NMT master. All other devices have the role of the NMT slave. Each NMT slave can be addressed via its individual Node-ID in the range from [1–127]. NMT services can be used to initiate, start, monitor, reset or stop CANopen devices. In doing so, the driver follows the state diagram shown in the following. The “Initialization” state is only reached after power on or by sending a “Reset Communication” or “Reset Node” NMT command. The “Pre-operational” state is automatically activated after initialization. The “Pre-operational” state is automatically activated after initialization.

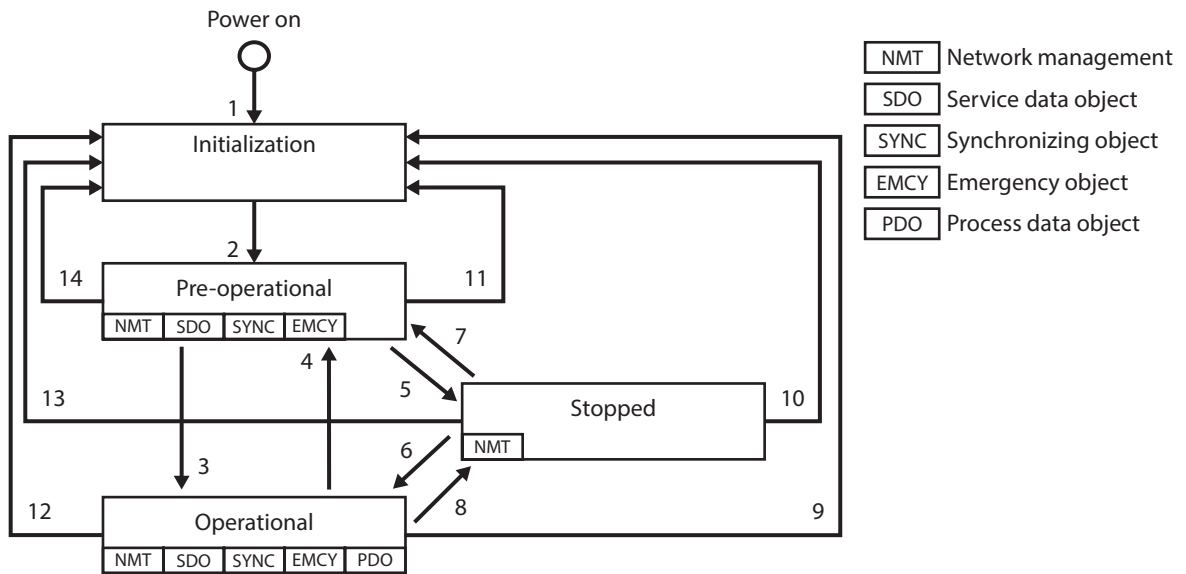

State	Description
1	At power on the NMT state initialization is entered autonomously
2	NMT state initialization finish, enter NMT state Pre-operational automatically
3	NMT service start remote node indication or by local control
4, 7	NMT service enter Pre-operational indication
5, 8	NMT service stop remote node indication
6	NMT service start remote node indication
9, 10, 11	NMT service reset node indication
12, 13, 14	NMT service reset communication indication

Shown in the following table is an overview of the activity of the services in the respective states.

Service	Initialization	Pre-operational	Operational	Stopped
PDO	–	–	Active	–
SDO	–	Active	Active	–
SYNC	–	Active	Active	–
EMCY	–	Active	Active	–
NMT	–	Active	Active	Active

NMT message:

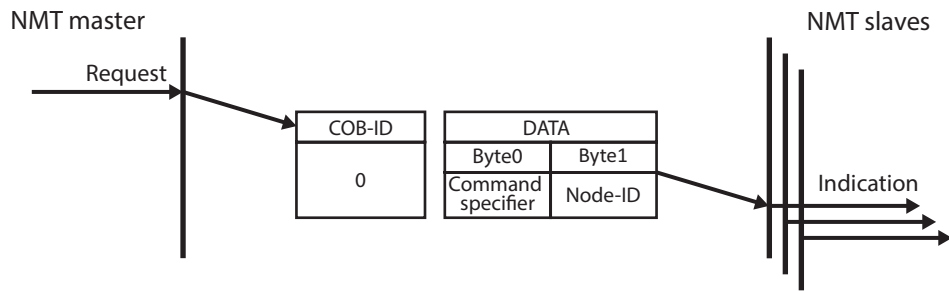

NMT message	COB-ID	DATA		Description
		Byte0	Byte1	
		Command specifier	Node-ID	
NMT service start remote node	0	01h	Node-ID	Switch to the "Operational" state
NMT service stop remote node	0	02h		Switch to the "Stoped" state
NMT service enter Pre-operational	0	80h		Switch to the "Pre-operational" state
NMT service reset node	0	81h		Reset Node
NMT service reset communication	0	82h		Reset Communication

4.2 NMT Error Control

The driver supports Node Guarding and Heartbeat protocol as NMT error controls.

4.2.1 Node Guarding

The NMT master polls each NMT slave at regular time intervals.

Set the time interval for node guarding message forwarding in "Guard time (100Ch)".

The NMT master sends a message to the NMT slave at that cycle, and the NMT slave responds with node guarding message. The response of the NMT slave contains the NMT state of that NMT slave.

A remote node error is indicated through the NMT service node guarding event if

- The RTR is not confirmed within the guard time.
- The reported NMT slave state does not match the expected state.

The node life time is given by the guard time multiplied by the "Life time factor (100Dh)". If the NMT slave has not been polled during its life time, a remote node error is indicated through the NMT service life guarding event.

If it has been indicated that a remote error has occurred and the errors in the guarding protocol have disappeared, it will be indicated that the remote error has been resolved through the NMT service node guarding event and the NMT service life guarding event.

- **Node guard request from NMT master**

COB-ID	RTR
700h + Node-ID	1

- **Node guard response from NMT slave**

COB-ID	RTR	DATA
		Byte0
700h + Node-ID	0	toggle bit + NMT state

- **Data Description of Byte 0**

Bit	Name	Description
0 to 6	NMT state	4 (04h): Stopped 5 (05h): Operational 127 (7Fh): Pre-operational
7	toggle bit	This bit is toggled on each response (0 at start).

● Node guarding message (in the case that NMT state is "Operational")

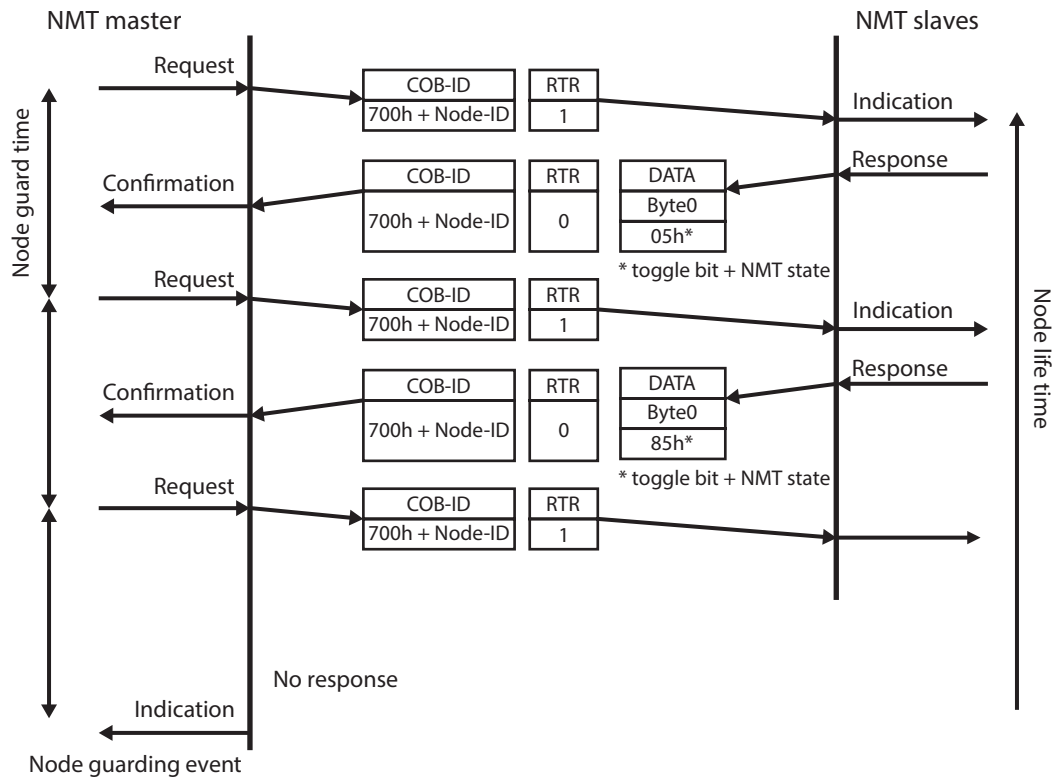

4.2.2 Heartbeat

The heartbeat protocol is an error control service without need for RTRs. A heartbeat producer transmits a heartbeat message cyclically. A heartbeat message transmission cycle is defined by the “Producer heartbeat time (1017h)”. One or more heartbeat consumer receives the indication. The relationship between producer and consumer is configurable via the object dictionary. The heartbeat consumer monitors whether the heartbeat was received within the time set in “Consumer heartbeat time (1016h)”.

If the heartbeat is not received within the consumer heartbeat time a heartbeat event will be generated.

If the heartbeat producer time is configured on the driver the heartbeat protocol begins immediately. If the driver starts with a value for the Producer heartbeat time unequal to 0 the heartbeat protocol starts on the transition from the NMT state Initialization to the NMT state Pre-operational.

In this case the boot-up message is regarded as first heartbeat message.

Notes:

- The consumer heartbeat time should be higher than the corresponding producer heartbeat time.
- A node is not allowed to support both Node Guarding and Heartbeat protocols at the same time.

● Heartbeat message

COB-ID	DATA
	Byte0
700h + Node-ID	NMT state

● Data Description of Byte 0

Bit	Name	Description
0 to 6	NMT state	0 (00h): Boot-up 4 (04h): Stopped 5 (05h): Operational 127 (7Fh): Pre-operational
7	reserved	Always 0

● Heartbeat message (in the case that NMT state is “Operational”)

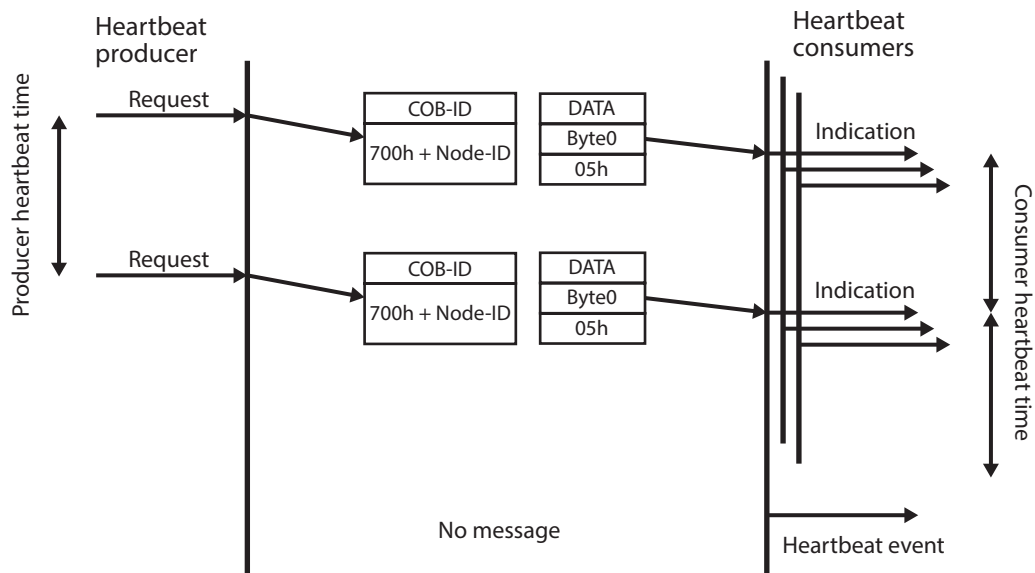

4.3 NMT boot-up

The driver transmits a boot up message after power on, communication reset, or application reset events. The protocol uses the same COB-ID as the error control protocols.

Boot-up message from CANOpen slave

COB-ID	DATA
	Byte0
700h + Node-ID	0

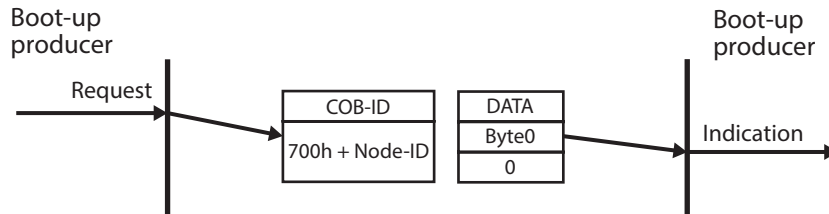

4.4 Synchronization object (SYNC)

The SYNC producer broadcasts the synchronization object periodically. This SYNC provides the basic network synchronization mechanism. The time period between the SYNCs is specified by the standard parameter "Communication cycle period (1006h)". SYNC messages carry no data. There must be only one SYNC producer in the network.

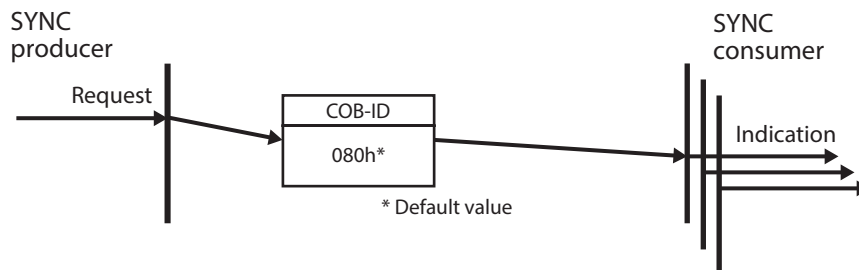

The COB-ID SYNC message of the SYNC object is 80h by default. To enable Sync producer mode, bit 30 must be set in "COB-ID SYNC message object (1005h)" after initialization of the network.

4.5 Emergency object (EMCY)

Emergency objects are triggered by the occurrence of the driver internal error situation and are transmitted from an emergency producer on the driver. Emergency objects are suitable for interrupt type error alerts. An emergency object is transmitted only once per 'error event'. No further emergency objects shall be transmitted as long as no new errors occur on the driver.

- **Emergency message**

COB-ID	DATA							
	Byte 0	Byte 1	Byte 2	Byte 3	Byte 4	Byte 5	Byte 6	Byte 7
080h + Node-ID	Emergency error code		Error register	00h	00h	00h	00h	00h

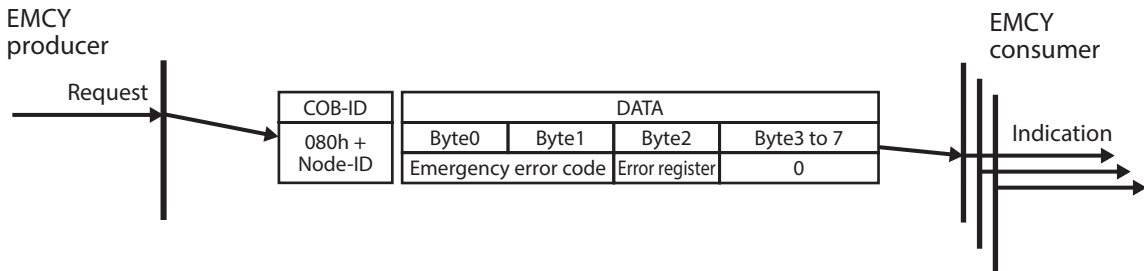

The driver is in one of two emergency states: Error Free or Error Occurred. Dependent on the transitions emergency objects is transmitted.

0. After initialization the driver enters the error free state if no error is detected. No error message is sent.
1. The driver detects an internal error indicated in the first three bytes of the emergency message (error code and error register). The driver enters the error state. An emergency object with the appropriate error code and error register is transmitted. The error code is filled in at the location of "Pre-defined error field (1003h)". The value of the error register is also saved in "Error register object (1001h)".
2. One, but not all error reasons are gone. An emergency message containing error code 0000h (Error reset) may be transmitted together with the remaining errors in the error register.
3. A new error occurs on the driver. The driver remains in error state and transmits an emergency object with the appropriate error code. The new error code is filled in at the top of the array of error codes (1003h). It is guaranteed that the error codes are sorted in a timely manner (oldest error - highest sub-index, see "Pre-defined error field (1003h)").
4. All errors are repaired. The driver enters the error free state and transmits an emergency object with the error code 'reset error / no error'.
5. Reset or power-off.

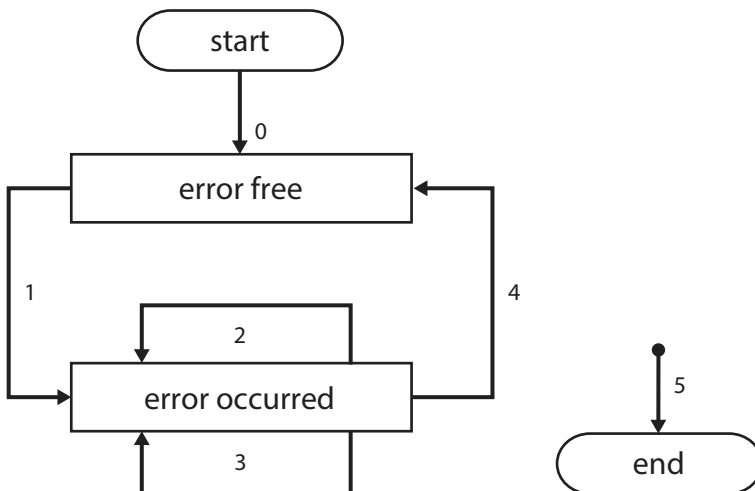

● **Error code and Error register**

Error code	Error register	Error description
0000h	00h	Error Reset or no error
8110h	11h	CAN overrun
8120h	11h	CAN in error passive mode
8130h	11h	Node guarding error or heartbeat error
8140h	11h	Recover from Bus-Off state
8210h	11h	PDO not processed due to length error
FF10h	81h	Position deviation Possible
FF20h	81h	Overcurrent Not possible Non-excitation
FF21h	81h	Main circuit overheat
FF22h	81h	Overvoltage Non-excitation
FF25h	81h	Undervoltage Non-excitation after
FF26h	81h	Motor overheat deceleration
FF28h	81h	Encoder error
FF29h	81h	Internal circuit error
FF2Ah	81h	Encoder communication error
FF30h	81h	Overload
FF31h	81h	Overspeed
FF41h	81h	EEPROM error
FF42h	81h	Initial encoder error
FF44h	81h	Encoder EEPROM error
FF45h	81h	Motor combination error
FF4Ah	81h	Return-to-home incomplete
FF50h	81h	Electromagnetic brake overcurrent
FF53h	81h	HWTO input circuit error
FF55h	81h	Electromagnetic brake connection error
FF60h	81h	±LS both sides active
FF61h	81h	Reverse ±LS connection
FF62h	81h	Return-to-home operation error
FF63h	81h	No HOMES
FF64h	81h	Z, SLIT signal error
FF66h	81h	Hardware overtravel
FF67h	81h	Software overtravel
FF68h	81h	HWTO input detection Non-excitation
FF6Ah	81h	Return-to-home additional operation error
FF70h	81h	Operation data error
FF71h	81h	Unit setting error
FF81h	81h	Network bus error
FF84h	81h	RS-485 communication error
FF85h	81h	RS-485 communication timeout
FF8Ch	81h	Outside setting range
FFF0h	81h	CPU error
FFF3h	81h	CPU overload

4.6 Service data object (SDO)

A Service Data Object (SDO) is providing direct access to object entries of the driver's object dictionary.

As these object entries may contain data of arbitrary size and data type.

SDO is a confirm service and operate under Client/Server model. SDOs may be used to transfer multiple data sets (each containing an arbitrary large block of data) from a client to a server and vice versa.

The client can control via index and sub-index of the object dictionary which data set shall be transferred.

The content of the data set is defined within the object dictionary.

Basically an SDO is transferred as a sequence of segments. Prior to transferring the segments there is an initialization phase where client and server prepare themselves for transferring the segments.

For SDOs, it is also possible to transfer a data set of up to 4 bytes during the initialization phase.

This mechanism is called SDO expedited transfer.

The following communication services are supported.

- SDO download initiate
- SDO download segment
- SDO upload initiate
- SDO upload segment
- SDO abort transfer

● SDO download

The client is using the service SDO download for transferring data from the client to the server (owner of the object dictionary: the driver). The SDO download consists of at least the SDO download initiate service and optionally of the SDO download segment services (data length > 4 bytes).

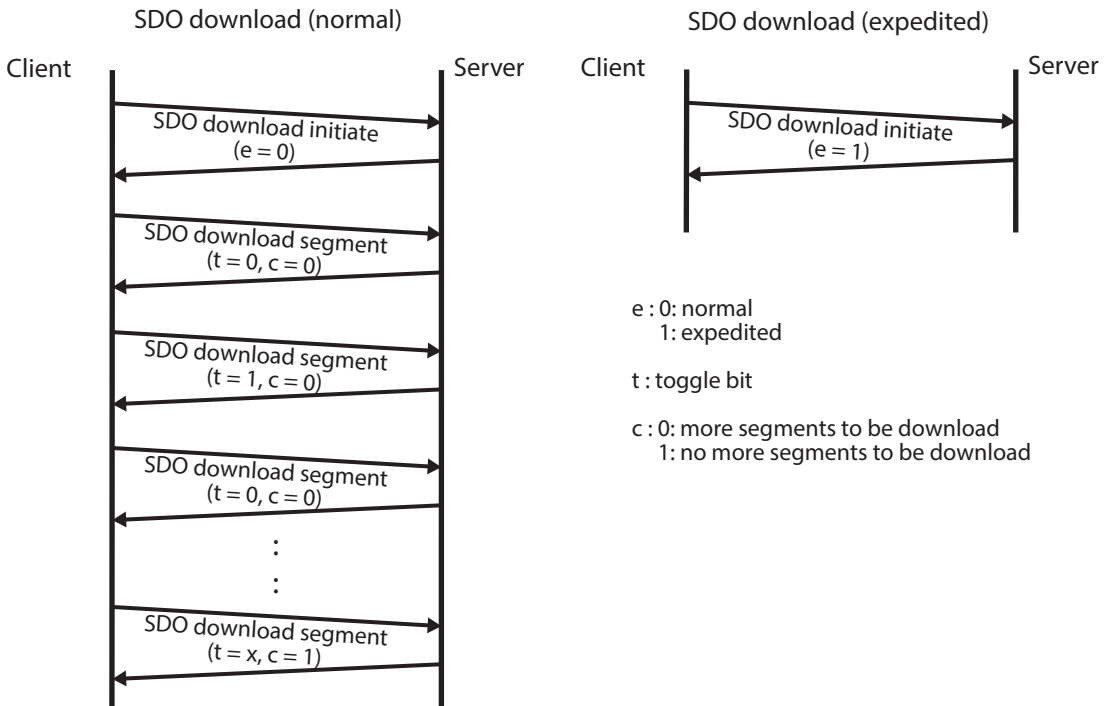

● **SDO upload**

The client is using the service SDO upload for transferring the data from the server (owner of the object dictionary: driver) to the client. The SDO upload consists of at least the SDO upload initiate service and optional of SDO upload segment services (data length > 4 bytes).

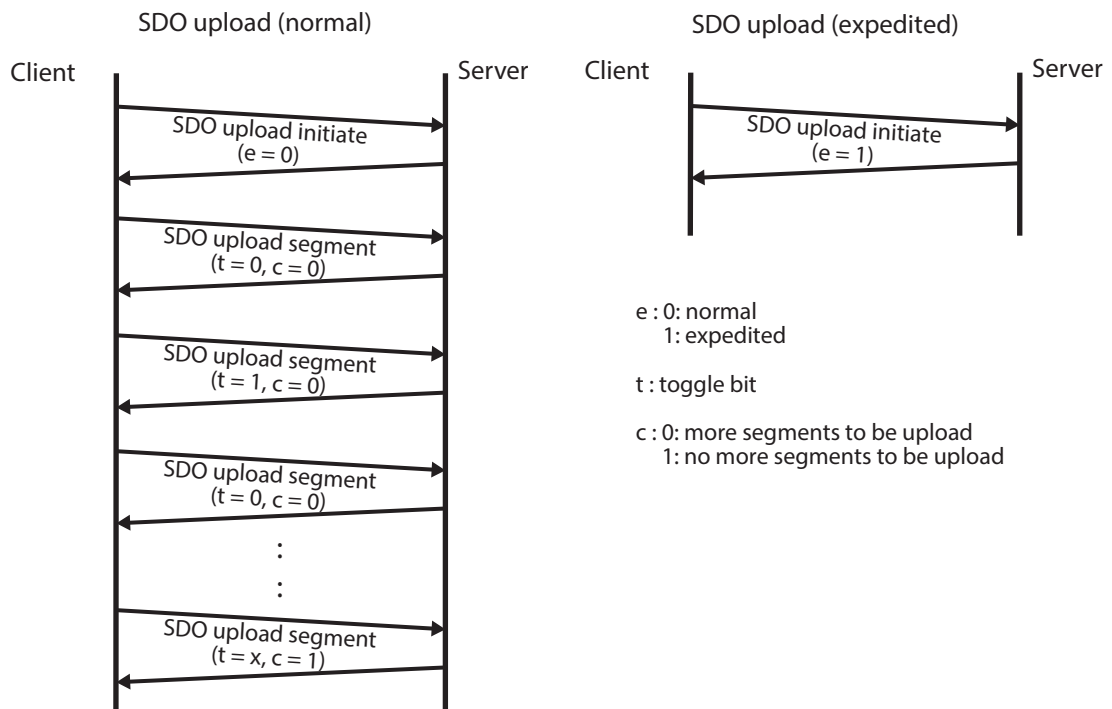

4.6.1 SDO download initiate

The client requests the server to prepare downloading of data by using the SDO download initiate service.

The multiplexer of the data set and the transfer type are indicated to the server.

In case of an SDO expedited download, the data of the data set identified by the Index and Sub-index is indicated to the server.

- SDO download initiate message

Client request

COB-ID	DATA														
	Byte 0								Byte 1	Byte 2	Byte 3	Byte 4	Byte 5	Byte 6	Byte 7
	Bit 7	Bit 6	Bit 5	Bit 4	Bit 3	Bit 2	Bit 1	Bit 0							
600h + Node-ID	CCS=1			x	n			c	s	Index (LSB)	Index (MSB)	Sub-Index	d		

Server response

COB-ID	DATA														
	Byte 0								Byte 1	Byte 2	Byte 3	Byte 4	Byte 5	Byte 6	Byte 7
	Bit 7	Bit 6	Bit 5	Bit 4	Bit 3	Bit 2	Bit 1	Bit 0							
580h + Node-ID	SCS=3			x				Index (LSB)	Index (MSB)	Sub-Index	Reserved always 0				

- CCS: client command specifier
 - 1: initiate download request
- SCS: server command specifier
 - 3: initiate download response
- n: Only valid if e = 1 and s = 1, otherwise 0.
 - If valid it indicates the number of bytes in d that do not contain data. Bytes [8-n, 7] do not contain data.
- e: transfer type
 - 0: normal transfer
 - 1: expedited transfer
- s: size indicator
 - 0: data set size is not indicated
 - 1: data set size is indicated
- d: data
 - e = 0, s = 0: d is reserved for further use.
 - e = 0, s = 1: d contains the number of bytes to be downloaded.
 - Byte 4 contains the LSB and byte 7 contains the MSB.
 - e = 1, s = 1: d contains the data of length 4-n to be downloaded. The encoding depends on the type of the data referenced by Index and Sub-index.
 - e = 1, s = 0: d contains unspecified number of bytes to be downloaded.
- x: not used, always 0

4.6.2 SDO download segment

The client transfers the segmented data to the server by using the SDO download service. The segment data and optionally its size are indicated to the server. The continue parameter indicates the server whether there are still more segments to be downloaded or that this was the last segment to be downloaded.

● SDO download segment message

Client request

COB-ID	DATA															
	Byte 0								Byte 1	Byte 2	Byte 3	Byte 4	Byte 5	Byte 6	Byte 7	
	Bit 7	Bit 6	Bit 5	Bit 4	Bit 3	Bit 2	Bit 1	Bit 0								
600h + Node-ID	CCS=0			t	n			c	seg-data							

Server response

COB-ID	DATA															
	Byte 0								Byte 1	Byte 2	Byte 3	Byte 4	Byte 5	Byte 6	Byte 7	
	Bit 7	Bit 6	Bit 5	Bit 4	Bit 3	Bit 2	Bit 1	Bit 0								
580h + Node-ID	SCS=1			t	x			Reserved always 0								

- CCS: client command specifier
 - 0: download segment request
- SCS: server command specifier
 - 1: download segment response
- seg-data: segments data
 - At most 7 bytes of segment data to be downloaded. The encoding depends on the type of the data referenced by index and sub-index.
- n: number of bytes
 - Indicates the number of bytes in segment data that do not contain segment data.
 - Bytes [8-n, 7] do not contain segment data. If n = 0 bytes 1 to 7 shall contain segment data.
 - NOTE: If the size in the initiation is indicated this applies to the overall data transferred.
- c: more segments
 - Indicates whether there are still more segments to be downloaded.
 - 0: more segments to be downloaded
 - 1: no more segments to be downloaded
- t: toggle bit
 - This bit is alternate for each subsequent segment that is downloaded. The first segment has the toggle-bit set to 0.
 - The toggle bit is equal for the request and the response message.
- x: not used, always 0

4.6.3 SDO upload initiate

The client requests the server to prepare the data for uploading by using the SDO upload initiate service. The Index and Sub-index of the data set whose upload is initiated is indicated to the server.

- SDO upload initiate message

Client request

COB-ID	DATA														
	Byte 0								Byte 1	Byte 2	Byte 3	Byte 4	Byte 5	Byte 6	Byte 7
	Bit 7	Bit 6	Bit 5	Bit 4	Bit 3	Bit 2	Bit 1	Bit 0							
600h + Node-ID	CCS=2		x					Index (LSB)	Index (MSB)	Sub-Index	Reserved always 0				

Server response

COB-ID	DATA														
	Byte 0								Byte 1	Byte 2	Byte 3	Byte 4	Byte 5	Byte 6	Byte 7
	Bit 7	Bit 6	Bit 5	Bit 4	Bit 3	Bit 2	Bit 1	Bit 0							
580h + Node-ID	SCS=2		x	n	e	s	Index (LSB)	Index (MSB)	Sub-Index	d					

- CCS: client command specifier
2: initiate upload request
- SCS: server command specifier
2: initiate upload response
- n: number of bytes
Only valid if e = 1 and s = 1, otherwise 0. If valid it indicates the number of bytes in d that do not contain data. Bytes [8-n, 7] do not contain segment data.
- e: transfer type
0: normal transfer
1: expedited transfer
- s: size indicator
0: data set size is not indicated
1: data set size is indicated
- d: data
e = 0, s = 0: d is reserved for further use.
e = 0, s = 1: d contains the number of bytes to be uploaded.
Byte 4 contains the LSB and byte 7 contains the MSB.
e = 1, s = 1: d contains the data of length 4-n to be uploaded. The encoding depends on the type of the data referenced by Index and Sub-index.
e = 1, s = 0: d contains unspecified number of bytes to be uploaded.
- x: not used, always 0

4.6.4 SDO upload segment

The client requests the server to supply the data of the next segment by using the SDO upload segment service. The continue parameter indicates the client whether there are still more segments to be uploaded or that this was the last segment to be uploaded. There is at most one SDO upload segment service outstanding for an SDO.

● SDO upload segment message

Client request

COB-ID	DATA															
	Byte 0								Byte 1	Byte 2	Byte 3	Byte 4	Byte 5	Byte 6	Byte 7	
	Bit 7	Bit 6	Bit 5	Bit 4	Bit 3	Bit 2	Bit 1	Bit 0								
600h + Node-ID	CCS=3			t	x				Reserved always 0							

Server response

COB-ID	DATA															
	Byte 0								Byte 1	Byte 2	Byte 3	Byte 4	Byte 5	Byte 6	Byte 7	
	Bit 7	Bit 6	Bit 5	Bit 4	Bit 3	Bit 2	Bit 1	Bit 0								
580h + Node-ID	SCS=0			t	n			c	seg-data							

- CCS: client command specifier
 - 3: upload segment request
- SCS: server command specifier
 - 0: upload segment response
- t: toggle bit
 - This bit shall alternate for each subsequent segment that is uploaded. The first segment shall have the toggle-bit set to 0. The toggle bit shall be equal for the request and the response message.
- c: more segments
 - Indicates whether there are still more segments to be uploaded.
 - 0: more segments to be uploaded
 - 1: no more segments to be uploaded
- seg-data: segments data
 - At most 7 bytes of segment data to be uploaded. The encoding depends on the type of the data referenced by Index and Sub-index.
- n: number of bytes
 - Indicates the number of bytes in seg-data that do not contain segment data.
 - Bytes [8-n, 7] do not contain segment data. If n = 0 bytes 1 to 7 shall contain segment data.
 - NOTE: If the size in the initiation is indicated this applies to the overall data transferred.
- x: not used, always 0

4.6.5 SDO abort transfer

The SDO abort transfer service aborts the SDO upload service or SDO download service of an SDO referenced by its number. The reason is indicated. The service is unconfirmed. Both the client and the server of an SDO may execute the service at any time. If the client of an SDO has a confirmed service outstanding, the indication of the abort is taken to be the confirmation of that service.

● **SDO abort message**

COB-ID	DATA														
	Byte 0								Byte 1	Byte 2	Byte 3	Byte 4	Byte 5	Byte 6	Byte 7
	Bit 7	Bit 6	Bit 5	Bit 4	Bit 3	Bit 2	Bit 1	Bit 0							
580h + Node-ID	CS=4			x				Index (LSB)	Index (MSB)	Sub-Index	d (LSB-MSB)				

- CS: command specifier
4: abort transfer request
- x: not used, always 0
- d: contains a 4 byte abort code about the reason for the abort.

● **SDO Abort Code**

Abort Code	Description
0503 0000h	Toggle bit not alternated
0504 0001h	Command specifier not valid
0601 0001h	Attempt to read a write only object
0601 0002h	Attempt to write a read only object
0602 0000h	Object does not exist in the object dictionary
0604 0041h	Object cannot be mapped to the PDO
0604 0042h	The number and length of the objects to be mapped would exceed PDO length
0606 0000h	Access failed due to a hardware error
0607 0010h	Data type does not match, length of service parameter does not match
0607 0012h	Data type does not match, length of service parameter too high
0607 0013h	Data type does not match, length of service parameter too low
0609 0011h	Sub-index does not exist
0609 0030h	Value range of parameter exceeded (only for write access)
0609 0031h	Value of parameter written too high
0609 0032h	Value of parameter written too low
0800 0000h	General error
0800 0020h	Data cannot be transferred or stored to the application
0800 0022h	Data cannot be transferred or stored to the application because of present device state
0800 0024h	No data available

4.7 Process data object (PDO)

The real-time data transfer is performed by means of "Process Data Objects (PDO)". The transfer of PDO is performed with no protocol overhead and it can be mapped to transport up to 8 data bytes in one CAN-frame. The PDO correspond to objects in the object dictionary and provide the interface to the application objects. Data type and mapping of application objects into a PDO is determined by a corresponding default PDO mapping structure within the object dictionary.

There are two kinds of use for PDO. The first is data transmission and the second data reception. It is distinguished in Transmit-PDO (TPDO) and Receive-PDO (RPDO). CANopen devices supporting TPDO are PDO producer and CANopen devices supporting RPDO are called PDO consumer. PDO are described by the PDO communication parameter and the PDO mapping parameter.

The driver supports the following parameters:

Receive-PDO (RPDO) (Master -> Driver)

- 1400h: 1st RPDO communication parameter
- 1401h: 2nd RPDO communication parameter
- 1402h: 3rd RPDO communication parameter
- 1403h: 4th RPDO communication parameter
- 1600h: 1st RPDO mapping parameter
- 1601h: 2nd RPDO mapping parameter
- 1602h: 3rd RPDO mapping parameter
- 1603h: 4th RPDO mapping parameter

Transmit-PDO (TPDO) (Driver -> Master)

- 1800h: 1st TPDO communication parameter
- 1801h: 2nd TPDO communication parameter
- 1802h: 3rd TPDO communication parameter
- 1803h: 4th TPDO communication parameter
- 1A00h: 1st TPDO mapping parameter
- 1A01h: 2nd TPDO mapping parameter
- 1A02h: 3rd TPDO mapping parameter
- 1A03h: 4th TPDO mapping parameter

Note: PDO can only be used if the NMT state machine is in the "Operational" state.

The PDO must be configured in the "Pre-operational" state.

● RPDO message

Name	COB-ID	DATA							
		Byte 0	Byte 1	Byte 2	Byte 3	Byte 4	Byte 5	Byte 6	Byte 7
1st RPDO	200h + Node-ID	1st RPDO mapping parameter(1600h) Sub-index 01h to 04h							
2nd RPDO	300h + Node-ID	2nd RPDO mapping parameter(1601h) Sub-index 01h to 04h							
3rd RPDO	400h + Node-ID	3rd RPDO mapping parameter(1602h) Sub-index 01h to 04h							
4th RPDO	500h + Node-ID	4th RPDO mapping parameter(1603h) Sub-index 01h to 04h							

● TPDO message

Name	COB-ID	DATA							
		Byte 0	Byte 1	Byte 2	Byte 3	Byte 4	Byte 5	Byte 6	Byte 7
1st TPDO	180h + Node-ID	1st TPDO mapping parameter(1A00h) Sub-index 01h to 04h							
2nd TPDO	280h + Node-ID	2nd TPDO mapping parameter(1A01h) Sub-index 01h to 04h							
3rd TPDO	380h + Node-ID	3rd TPDO mapping parameter(1A02h) Sub-index 01h to 04h							
4th TPDO	480h + Node-ID	4th TPDO mapping parameter(1A03h) Sub-index 01h to 04h							

4.7.1 PDO mapping

You use the "RPDO mapping parameter (1600h to 1603h)" and the "TPDO mapping parameter (1A00h to 1A03h)" objects to change the PDO mapping.

You change the PDO mapping as follows:

1. Deactivate the PDO by setting the Valid Bit (bit 31) of Sub-index 01h of the corresponding communication parameter (e.g., 1400h: 01h) to "1".
2. Deactivate the mapping by setting Sub-index 00h of the corresponding mapping parameter (e.g., 1600h: 00h) to "0".
3. Change the mapping in the desired Sub-index (e.g., 1600h: 01h).
4. Activate the mapping by writing the number of objects that are to be mapped in Sub-index 00h of the corresponding mapping parameter (e.g., 1600h: 00h).
5. Activate the PDO by setting bit 31 of Sub-index 01h of the corresponding communication parameter (e.g., 1400h: 01h) to "0".

4.7.2 Transmission type

You can be set the transmission type as in the table below.

● **RPDO transmission type**

Transmission type	PDO Transmission
00h	Reflect the received data when receiving SYNC.
FEh	Reflect the received data Immediately.*1*2
FFh	Reflect the received data Immediately.

*1 The driver executes the following contents when received data in this transmission type.

- The driver Issue RTR to the corresponding TPDO
- The driver reset the node lifetime

*2 The driver with firmware version 2.02 or later support it.

(This "firmware version" does not mean "software version object (100Ah)")

● **TPDO transmission type**

Transmission type	PDO Transmission
00h	Sample it if the value of the mapping object has changed from the last transmission value. After that, transmit the value when receiving SYNC.
01h to F0h	Sample and transmit the value of the mapping object at the "n" th SYNC reception.
F1h to FBh	Reserved
FCh	Sample the value of the mapping object at the SYNC reception. After that, transmit the value when receiving RTR.
FDh	Sample and transmit the value of the mapping object at the RTR reception.
FEh, FFh	Sample and transmit the value of the mapping object when the following event. - If the value of the mapping object is changed from the last transmission after the set time of "Inhibit time (180xh: 03h)" has passed since the last transmission. - If an event occurred by the "Event timer (180xh: 05h)".

Note: An attempt to change the value of the transmission type to any not supported value is responded with the SDO abort transfer service (abort code: 0609 0030h).

5 Device control

The device control of the driver can be used to carry out all the motion functions in the corresponding modes. The control of the driver is implemented through a mode-dependent status machine. The status machine is controlled through the Object "Controlword (6040h)".

The states of the status machine can be revealed by using the Object "Statusword (6041h)".

5.1 Status Machine

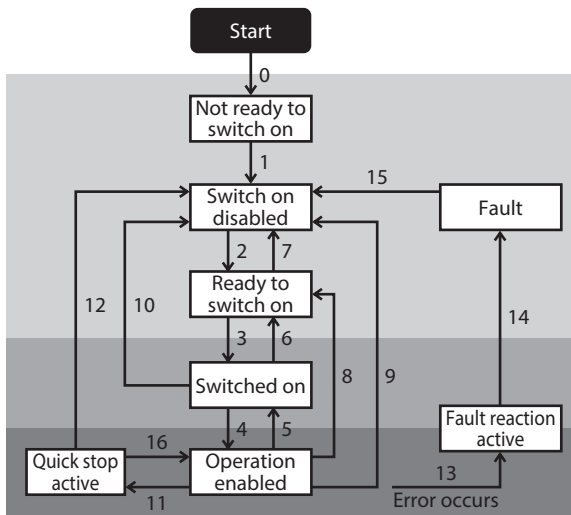

Main Power	NMT	Motor
ON	-	Non-excitation
ON	Operational	Non-excitation
ON	Operational	Excitation

State	Description	Motor status	Parameter setting
Not ready to switch on	The main power supply was turned on, and the initialization is executing.	Non-excitation	Not possible
Switch on disabled	The initialization was complete.	Non-excitation	Possible
Ready to switch on	Drive functions cannot be carried out yet.	Non-excitation	Possible
Switched on	Drive functions cannot be carried out yet.	Non-excitation	Possible
Operation enabled	Drive functions are enabled.	Excitation	Possible
Quick stop active	The Quick stop command was received, and the operation stop is processing.	Excitation	Possible
Fault reaction active	- A fault has occurred in the driver. - A non-excitation alarm (or non-excitation after slow down alarm) has occurred in the driver, and the operation stop is processing.	Excitation	Possible
Fault	- A non-excitation alarm (or non-excitation after slow down alarm) is present in the driver.	Non-excitation	Possible

6 Status Machine control commands

Command	Bits in Controlword (6040h)					Transitions
	Fault reset	Enable operation	Quick stop	Enable voltage	Switched on	
	Bit7	Bit3	Bit2	Bit1	Bit0	
Shutdown	0	X	1	1	0	2, 6, 8
Switch ON	0	0	1	1	1	3
Switch ON + Enable Operation	0	1	1	1	1	3 + 4 *
Disable Voltage	0	X	X	0	X	7, 9, 10, 12
Quick Stop	0	X	0	1	X	7, 10, 11
Disable Operation	0	0	1	1	1	5
Enable Operation	0	1	1	1	1	4, 16
Fault Reset	0 → 1	X	X	X	X	15

Bits marked by an X are irrelevant.

* Automatic transition to enable operation state after executing switched on state functionality.

6.1 Bits in Statusword (6041h)

Bit	Data Description	Remarks
0	Ready to Switch ON	Refer to the following section for details. -> 7.2.4 Statusword of the Profile Velocity Mode 7.3.4 Statusword of the Profile Position Mode 7.4.4 Statusword of the Homing Mode
1	Switched ON	
2	Operation Enabled	
3	Fault	
4	Voltage Enabled	
5	Quick Stop	
6	Switch ON Disabled	
7	Warning	
8	Drive profile operation ready (manufacturer-specific (MS))	
9	Remote	
10	Target Reached	
11	Internal Limit Active	
12	Operation Mode Specific (OMS)	
13		
14	Reserved (manufacturer-specific (MS))	
15	TLC (manufacturer-specific (MS))	

6.2 Transitions of the status machine

Transition	Event	Action
0	Power on reset	Initialization
1	Initialization completed successfully.	Activate communication and process data monitoring.
2	“Shutdown” command received from controlword.	None
3	“Switch On” command received from controlword.	None
4	“Enable Operation” command received from controlword.	The drive function is enabled.
5	“Disable operation” command received from controlword.	The drive function is disabled.
6	- “Shutdown” command received from controlword. - “FREE signal input” is active.	None
7	- “Quick Stop” command received from controlword. - “QSTOP signal input” is active. - “HWTO signal input” is active.	None
8	- “Shutdown” command received from controlword. - “FREE signal input” is active.	Drive function is disabled and the motor is free to rotate if unbraked.
9	- “Disable Voltage” command received from controlword. - “HWTO signal input” is active.	Output stage is disabled.
10	- “Disable Voltage” or “Quick Stop” command received from controlword. - “QSTOP signal input” is active. - “HWTO signal input” is active.	Drive function is disabled and the motor is free to rotate if unbraked.
11	- “Quick Stop” command received from controlword. - “QSTOP signal input” is active.	The Quick Stop function is executed.
12	- “Quick Stop” function is completed or “Disable Voltage” command received from controlword. - “HWTO signal input” is active.	Drive function is disabled.
13	A fatal fault has occurred in the driver.	Execute appropriate fault reaction.
14	The fault reaction is completed.	The drive function is disabled.
15	- “Fault reset” command received from controlword. - “ALM-RST signal input” is active.	None
16	Not supported.	–

6.3 Related Objects

Index	Sub-index	Name	Type	Access	PDO mapping	Unit (default)
6040h	00h	Controlword	UINT16	rww	Yes	–
6041h	00h	Statusword	UINT16	ro	Yes	–
605Ah	00h	Quick stop option code	INT16	rw	No	–
605Bh	00h	Shutdown option code	INT16	rw	No	–
605Ch	00h	Disable operation option code	INT16	rw	No	–
605Dh	00h	Halt option code	INT16	rw	No	–
605Eh	00h	Fault reaction option code	INT16	rw	No	–

7 Operation mode

7.1 Modes of Operation

7.1.1 General Information

The driver supports the operation modes listed below.

- Profile Position Mode (pp)
- Profile Velocity Mode (pv)
- Homing Mode (hm)

7.1.2 Related Objects

Index	Sub-index	Name	Type	Access	PDO mapping	Unit (default)
6060h	00h	Modes of operation	INT8	rww	Yes	-
6061h	00h	Modes of operation display	INT8	ro	Yes	-
6502h	00h	Supported drive modes	UINT32	ro	Yes	-

7.2 Profile Velocity Mode (pv)

7.2.1 General Information

In the Profile Velocity Mode, the speed is output according to the profile acceleration and profile deceleration until it reaches the target velocity.

The following figure shows the block diagram for the Profile Velocity Mode.

- **PV use a trajectory generator for positioning [When the (6040h: bit12) is 0]**

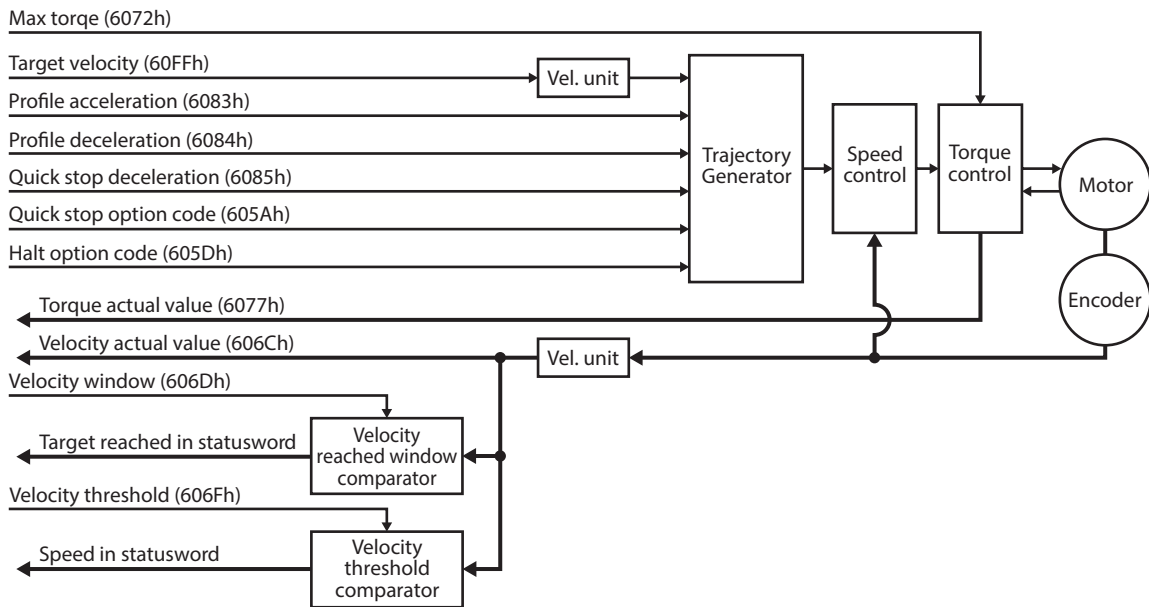

- **PV use a trajectory generator for positioning [When the (6040h: bit12) is 1]**

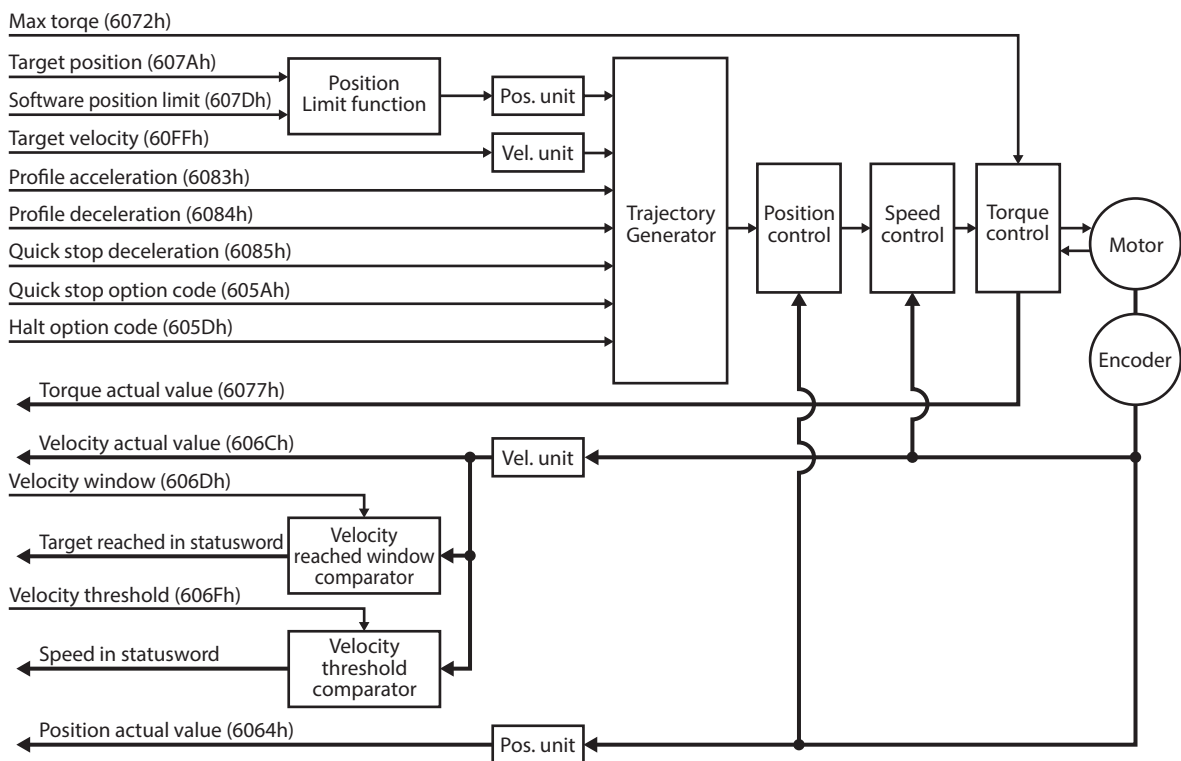

7.2.2 Related Objects

Index	Sub-index	Name	Type	Access	PDO mapping	Unit (default)
6040h	00h	Controlword	UINT16	rww	Yes	–
6041h	00h	Statusword	UINT16	ro	Yes	–
605Ah	00h	Quick stop option code	INT16	rw	No	–
605Dh	00h	Halt option code	INT16	rw	No	–
6064h	00h	Position actual value	INT32	ro	Yes	Pos. unit (step)
606Ch	00h	Velocity actual value	INT32	ro	Yes	Vel. unit (r/min)
606Dh	00h	Velocity window	UINT16	rww	Yes	Vel. unit (r/min)
606Fh	00h	Velocity threshold	UINT16	rww	Yes	Vel. unit (r/min)
6072h	00h	Max torque	UINT16	rww	Yes	1=0.1%
6077h	00h	Torque actual value	INT16	ro	Yes	1=0.1%
607Ah	00h	Target position	INT32	rww	Yes	Pos. unit (step)
607Dh	Software position limit					
	00h	Highest Sub-index Supported	UINT8	c	No	–
	01h	Min position limit	INT32	rww	Yes	Pos. unit (step)
	02h	Max position limit	INT32	rww	Yes	Pos. unit (step)
6083h	00h	Profile acceleration	UINT32	rww	Yes	Acc. unit ((r/min)/s)
6084h	00h	Profile deceleration	UINT32	rww	Yes	Acc. unit ((r/min)/s)
6085h	00h	Quick stop deceleration	UINT32	rww	Yes	Acc. unit ((r/min)/s)
60FFh	00h	Target velocity	INT32	rww	Yes	Vel. unit (r/min)

7.2.3 Controlword of the Profile Velocity Mode

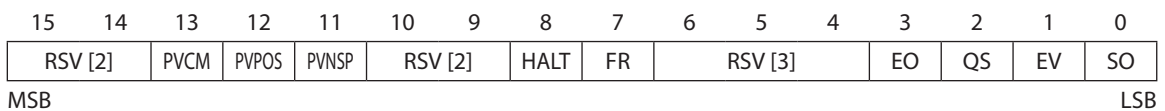

Bit	Notation	Meaning	Description
0	SO	Switch on	Status Machine control commands
1	EV	Enable voltage	
2	QS	Quick stop	
3	EO	Enable operation	
4 to 6	RSV	Reserved	Reserved
7	FR	Fault reset	0 -> 1: Alarm reset
8	HALT	Halt	0: Executes or continues operation. 1: Stops the motor according to halt option code (605Dh).
9, 10	RSV	Reserved	Reserved
11	PVNSP	New set point of PV using a trajectory generator for positioning.	0 -> 1: Starts the next PV-positioning operation immediately.
12	PVPOS	PV use a trajectory generator for positioning	0: A trajectory generator for positioning is disabled. 1: A trajectory generator for positioning is enabled.
13	PVCM	PV control mode	0: Motion extension 1: Normal
14 to 15	RSV	Reserved	Reserved

Note: If the Remote bit of the statusword (6041h: bit 9) is 0, the Controlword other than “Quick stop”, “Fault reset”, and “Halt” are invalid.

7.2.4 Statusword of the Profile Velocity Mode

15	14	13	12	11	10	9	8	7	6	5	4	3	2	1	0
TLC	RSV	RSV	SPD	ILA	TR	RM	DPRDY	WNG	SOD	QS	VE	FAULT	OE	SO	RTSO
MSB														LSB	

Bit	Notation	Meaning	Description
0	RTSO	Ready to switch on	Current state of the driver
1	SO	Switch on	
2	OE	Operation enabled	
3	FAULT	Fault	
4	VE	Voltage enabled	
5	QS	Quick stop	
6	SOD	Switch on disabled	
7	WNG	Warning	0: No alarm occurred 1: Alarm occurred
8	DPRDY	Drive profile operation ready	0: Not ready for operation 1: Ready for operation
9	RM	Remote	0: Controlword is not processed. * 1: Controlword is processed.
10	TR	Target reached	0: Halt (bit 8 in controlword) = 0: The target speed has not been reached. Halt (bit 8 in controlword) = 1: The motor is decelerating. 1: Halt (bit 8 in controlword) = 0: The target speed was reached. Halt (bit 8 in controlword) = 1: The motor is stopped.
11	ILA	Internal limit active	The internal limit is activated in the following cases: - The software limit was activated. - The FW-LS or RV-LS signal was activated. - The FW-BLK or RV-BLK signal was activated. - The STOP or QSTOP signal was activated. - The CLR signal was activated.
12	SPD	Speed	0: The speed is not 0. 1: The speed is 0.
13	RSV	Reserved	Reserved
14	RSV	Reserved	Reserved
15	TLC	Torque limit control	The torque limit control is activated in the following cases: - The actual torque reaches the maximum output torque. - The actual torque reaches the torque limiting value.

* The Remote (bit 9) is "0" when any of the following conditions.

- The S-ON signal is active.
- Remote operation, data writing, or I/O test is executed with the support soft.

7.2.5 Operation in the Profile Velocity Mode

- PV use a trajectory generator for positioning [When the (6040h: bit12) is 0]

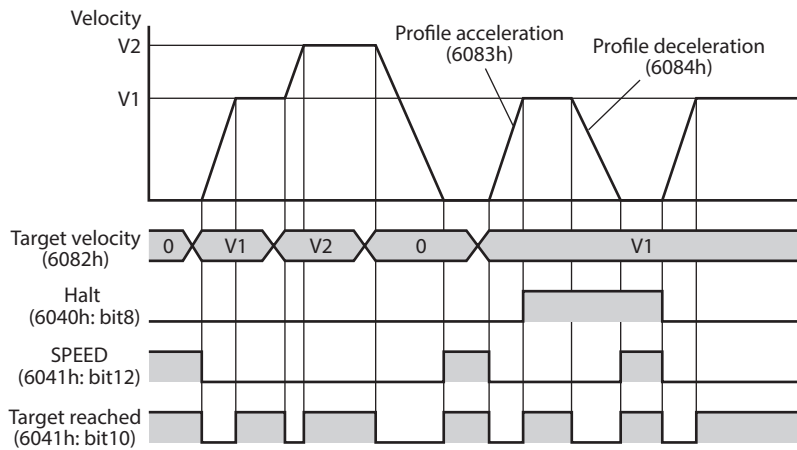

- PV use a trajectory generator for positioning [When the (6040h: bit12) is 1]

This operation treats absolute value of the target position (607Ah) as a relative movement distance. The rotary direction is according to sign of the target velocity (60FFh).

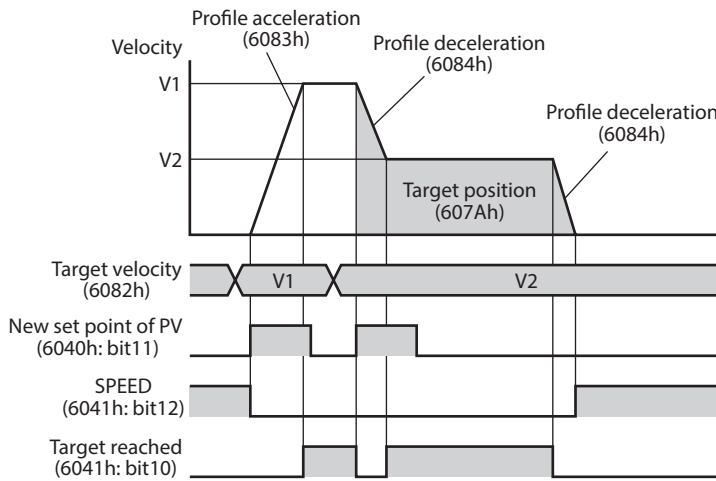

7.3 Profile Position Mode (pp)

7.3.1 General Information

The Profile Position Mode is used to position to the target position at the profile velocity and the profile acceleration. The following figure shows the block diagram for the Profile Position Mode.

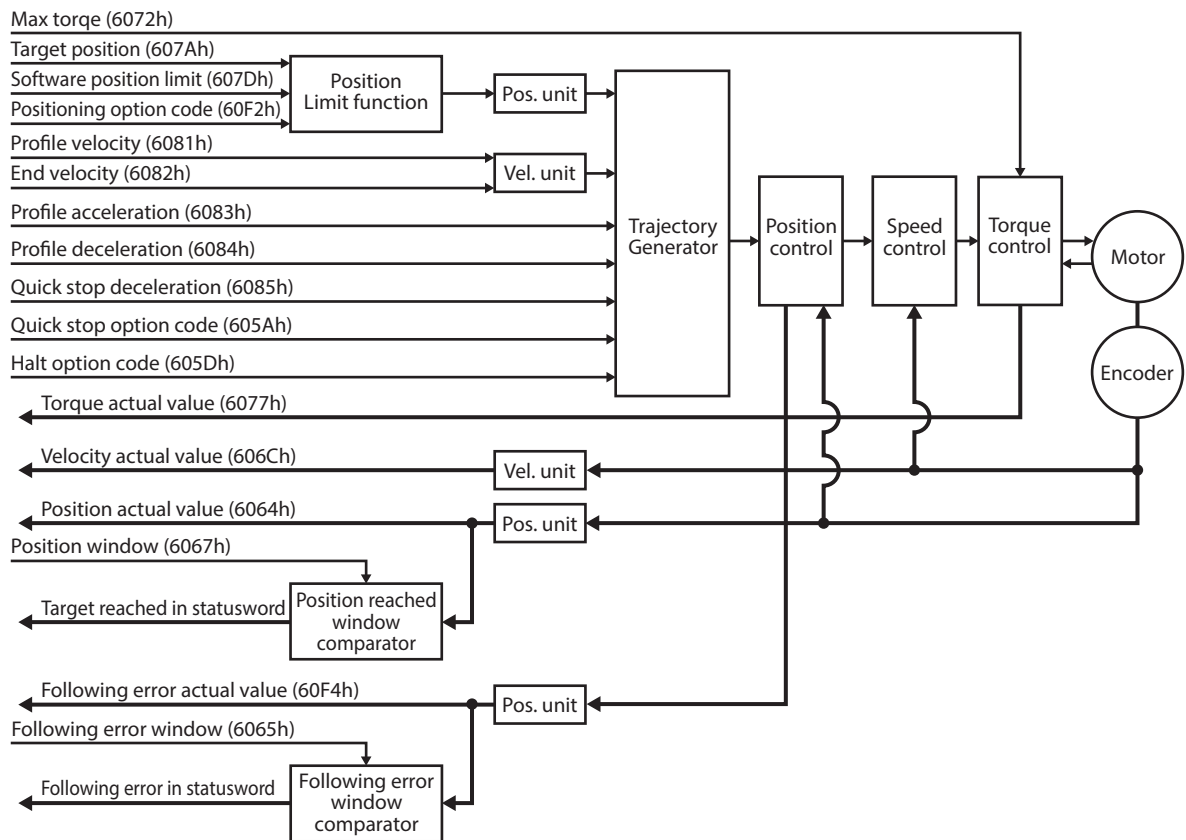

7.3.2 Related Objects

Index	Sub-index	Name	Type	Access	PDO mapping	Unit (default)
6040h	00h	Controlword	UINT16	rww	Yes	–
6041h	00h	Statusword	UINT16	ro	Yes	–
605Ah	00h	Quick stop option code	INT16	rw	No	–
605Dh	00h	Halt option code	INT16	rw	No	–
6062h	00h	Position demand value	INT32	ro	Yes	Pos. unit (step)
6064h	00h	Position actual value	INT32	ro	Yes	Pos. unit (step)
6065h	00h	Following error window	UINT32	rww	Yes	Pos. unit (step)
6067h	00h	Position window	UINT32	rww	Yes	Pos. unit (step)
606Ch	00h	Velocity actual value	INT32	ro	Yes	Vel. unit (r/min)
6072h	00h	Max torque	UINT16	rww	Yes	1=0.1%
6077h	00h	Torque actual value	INT16	ro	Yes	1=0.1%
607Ah	00h	Target position	INT32	rww	Yes	Pos. unit (step)
607Dh	Software position limit					
	00h	Highest Sub-index Supported	UINT8	c	No	–
	01h	Min position limit	INT32	rww	Yes	Pos. unit (step)
	02h	Max position limit	INT32	rww	Yes	Pos. unit (step)
6081h	00h	Profile velocity	UINT32	rww	Yes	Vel. unit (r/min)
6082h	00h	End velocity	UINT32	rww	Yes	Vel. unit (r/min)
6083h	00h	Profile acceleration	UINT32	rww	Yes	Acc. unit ((r/min)/s)
6084h	00h	Profile deceleration	UINT32	rww	Yes	Acc. unit ((r/min)/s)
6085h	00h	Quick stop deceleration	UINT32	rww	Yes	Acc. unit ((r/min)/s)
60F2h	00h	Positioning option code	UINT16	rww	Yes	–

7.3.3 Controlword of the Profile Position Mode

15	14	13	12	11	10	9	8	7	6	5	4	3	2	1	0	
RSV [6]						COSP	HALT	FR	REL	IMM	NSP	EO	QS	EV	SO	
MSB																LSB

Bit	Notation	Meaning	Description
0	SO	Switch on	Status Machine control commands
1	EV	Enable voltage	
2	QS	Quick stop	
3	EO	Enable operation	
4	NSP	New set point	
5	IMM	Change set immediately	Refer to following table.
6	REL	Abs/rel	0: Treats the target position as an absolute value. 1: Treats the target position as a relative value. (Treats it as the movement distance from the current target position.)
7	FR	Fault reset	0 -> 1: Alarm reset
8	HALT	Halt	0: Executes or continues positioning. 1: Stops the motor according to halt option code (605Dh).
9	COSP	Change on set point	Not supported. It must be set to "0".
10 to 15	RSV	Reserved	Reserved

Change set immediately	New set point	Description
Bit 5	Bit 4	
0	0 → 1	Starts the next positioning operation after the current positioning operation is completed (i.e., after the target is reached).
1	0 → 1	Starts the next positioning operation immediately.

Note: If the Remote bit of the Statusword (6041h: bit 9) is 0, the Controlword other than "Quick stop", "Fault reset", and "Halt" are invalid.

7.3.4 Statusword of the Profile Position Mode

15	14	13	12	11	10	9	8	7	6	5	4	3	2	1	0
TLC	RSV	ERROR	SPA	ILA	TR	RM	DPRDY	WNG	SOD	QS	VE	FAULT	OE	SO	RTSO
MSB														LSB	

Bit	Notation	Meaning	Description
0	RTSO	Ready to switch on	Current state of the driver
1	SO	Switch on	
2	OE	Operation enabled	
3	FAULT	Fault	
4	VE	Voltage enabled	
5	QS	Quick stop	
6	SOD	Switch on disabled	
7	WNG	Warning	0: No alarm occurred 1: Alarm occurred
8	DPRDY	Drive profile operation ready	0: Not ready for operation 1: Ready for operation
9	RM	Remote	0: Controlword is not processed. * 1: Controlword is processed.
10	TR	Target reached	0: Halt (bit 8 in controlword) = 0: The target position has not been reached. Halt (bit 8 in controlword) = 1: The motor is decelerating. 1: Halt (bit 8 in controlword) = 0: The target position was reached. Halt (bit 8 in controlword) = 1: The motor is stopped.
11	ILA	Internal limit active	The internal limit is activated in the following cases: - The software limit was activated. - The FW-LS or RV-LS signal was activated. - The FW-BLK or RV-BLK signal was activated. - The STOP, QSTOP, or CLR signal was activated.
12	SPA	Set point acknowledge	0: Processing of previous set-point (reference) was completed and the driver is waiting for a new set-point. 1: Processing the previous set-point is still in process or a set-point was acknowledged.
13	ERROR	Following error	0: No following error 1: Following error
14	RSV	Reserved	Reserved
15	TLC	Torque limit control	The torque limit control is activated in the following cases: - The actual torque reaches the maximum output torque. - The actual torque reaches the torque limiting value.

* The Remote (bit 9) is "0" when any of the following conditions.
 - The S-ON signal is active.
 - Remote operation, data writing, or I/O test is executed with the support soft.

7.3.5 Operation in the Profile Position Mode

Positioning operation is started when the "Target position (607Ah)" is set and the "New set point (6040h: bit4)" is set to 1.

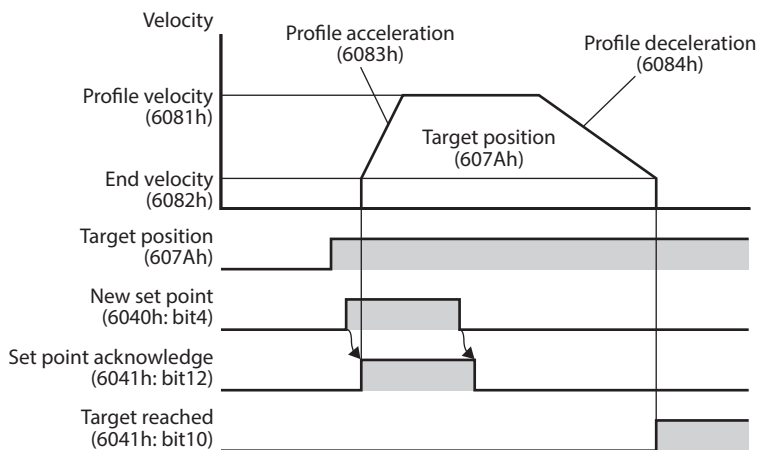

- **Single set-point [When the "Change set immediately (6040h: bit5)" is 1]**

If the "New set point (6040h: bit4)" is set during operation, the new operation command is applied immediately.

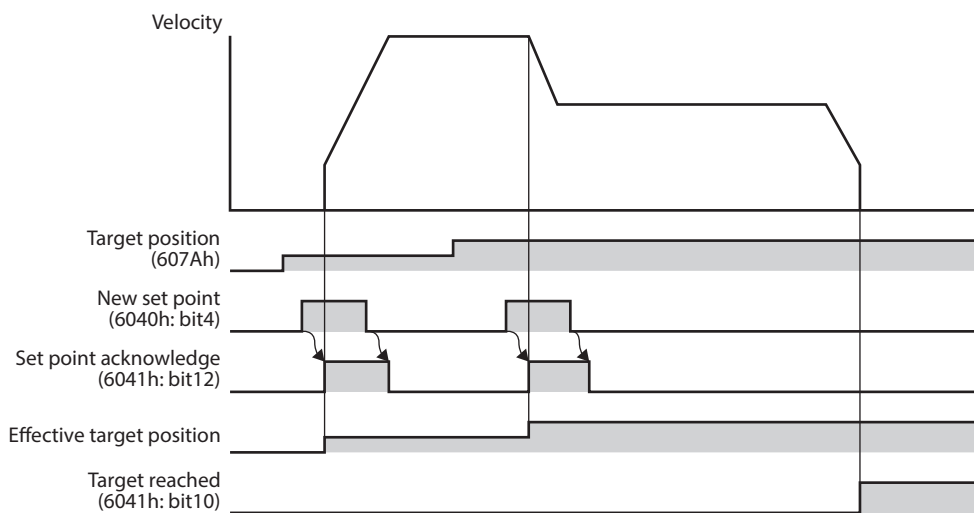

- **Set of set-points [When the "Change set immediately (6040h: bit5)" is 0]**

If the "New set point (6040h: bit4)" is set during operation, the new operation command is stored. When the present operation is complete, the stored new operation command is started.

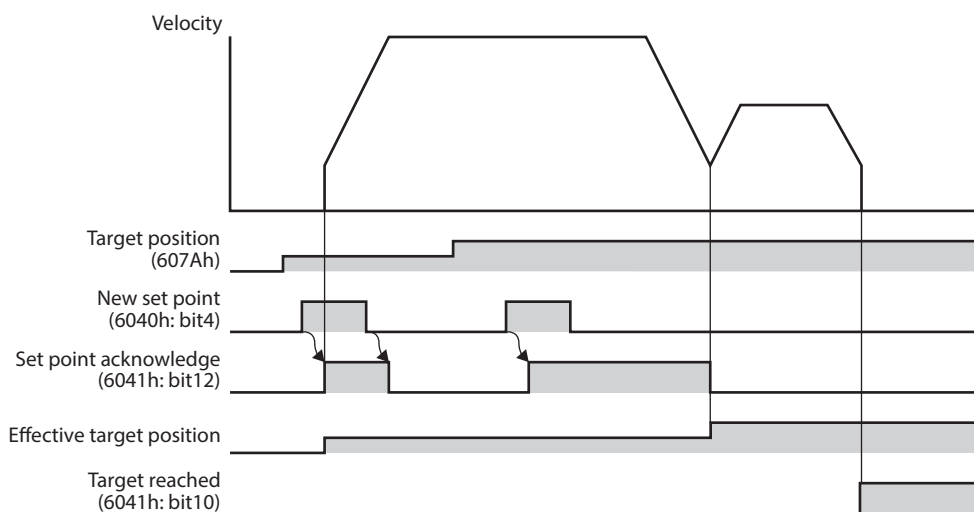

7.3.6 Positioning option code (60F2h)

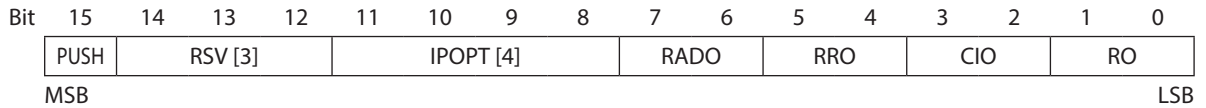

Bit	Notation	Meaning	Description
0, 1	RO	Relative option	Refer to following table.
2, 3	CIO	Change immediately option	Not supported.
4, 5	RRO	Request-response option	Not supported.
6, 7	RADO	Rotary axis direction option	Refer to following table.
8 to 11	ILOPT	IP option	Not supported.
12 to 14	RSV	Reserved	Reserved
15	PUSH	Push-motion	Refer to following table.

Bits in Controlword (6040h)	Bits in Positioning option code (60F2h)					Operation Mode	
	Abs / rel	Push-motion	Rotary axis direction option		Relative option		
	Bit 6	Bit 15	Bit 7	Bit 6	Bit 1		Bit 0
0	0	0	0	X	X	Absolute positioning/Wrap absolute positioning *	
0	0	0	1	X	X	Wrap reverse direction absolute positioning *	
0	0	1	0	X	X	Wrap forward direction absolute positioning *	
0	0	1	1	X	X	Wrap proximity positioning *	
0	1	0	0	X	X	Absolute positioning push-motion/Wrap absolute push-motion *	
0	1	0	1	X	X	Wrap reverse direction push-motion *	
0	1	1	0	X	X	Wrap forward direction push-motion *	
0	1	1	1	X	X	Wrap proximity push-motion *	
1	0	0	0	0	0	Incremental positioning (based on target position)	
1	0	0	0	0	1	Incremental positioning (based on demand position)	
1	0	0	0	1	0	Incremental positioning (based on actual position)	
1	0	0	0	1	1	Reserved	
1	1	0	0	0	0	Incremental positioning push-motion (based on target position)	
1	1	0	0	0	1	Incremental positioning push-motion (based on command position)	
1	1	0	0	1	0	Incremental positioning push-motion (based on actual position)	
1	1	0	0	1	1	Reserved	

* To do this, Object 607Bh(Position range limit) must have set.

Bits marked by an X are irrelevant.

Refer to the following for details on the operation mode.

- OPERATING MANUAL **BLV** Series **R** Type Function Edition

7.4 Homing Mode (hm)

7.4.1 General Information

The following figure shows the relationship between the input objects and the output objects in the Homing Mode. You can specify the speeds, acceleration rate, and homing method.

You can also use home offset to offset zero in the user coordinate system from the home position.

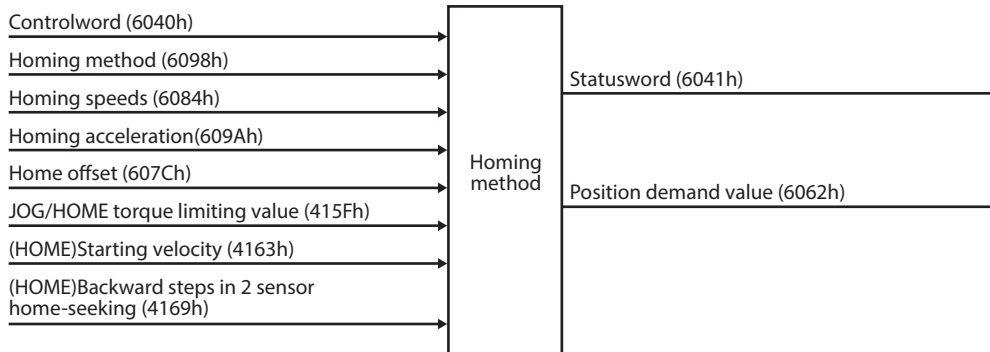

7.4.2 Related Objects

Index	Sub-index	Name	Type	Access	PDO mapping	Unit (default)
6040h	00h	Controlword	UINT16	rww	Yes	–
6041h	00h	Statusword	UINT16	ro	Yes	–
6062h	00h	Position demand value	INT32	ro	Yes	Pos. unit (step)
607Ch	00h	Home offset	INT32	rww	Yes	Pos. unit (step)
6098h	00h	Homing method	INT8	rww	Yes	–
6099h	Homing speeds					
	00h	Highest sub-index supported	UINT8	c	No	–
	01h	Speed during search for switch	UINT32	rww	Yes	Vel. unit (r/min)
	02h	Speed during search for zero	UINT32	rww	Yes	Vel. unit (r/min)
609Ah	00h	Homing acceleration	UINT32	rww	Yes	Acc. unit ((r/min)/s)
415Fh	00h	JOG/HOME torque limiting value	UINT32	rww	Yes	1=0.1%
4163h	00h	(HOME) Starting velocity	UINT32	rww	Yes	Vel. unit (r/min)
4169h	00h	(HOME) Backward steps in 2 sensor home-seeking	UINT32	rww	Yes	Pos. unit (step)

7.4.3 Controlword of the Homing Mode

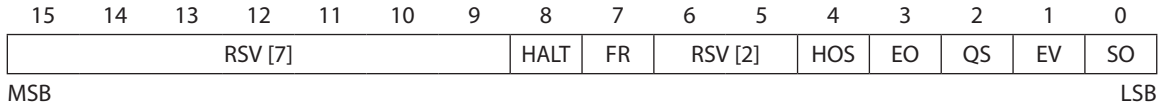

Bit	Notation	Meaning	Description
0	SO	Switch on	Status Machine control commands
1	EV	Enable voltage	
2	QS	Quick stop	
3	EO	Enable operation	
4	HOS	Homing operation start	0: Does not start homing procedure. 1: Starts or continues homing procedure.
5, 6	RSV	Reserved	Reserved
7	FR	Fault reset	0 -> 1: Alarm reset
8	HALT	Halt	0: Enable bit 4. 1: Stops the motor according to halt option code (605Dh).
9 to 15	RSV	Reserved	Reserved

Note: If the Remote bit of the statusword (6041h: bit 9) is 0, the Controlword other than "Quick stop", "Fault reset", and "Halt" are invalid.

7.4.4 Statusword of the Homing Mode

15	14	13	12	11	10	9	8	7	6	5	4	3	2	1	0
TLC	RSV	HE	HA	ILA	TR	RM	DPRDY	W	SOD	QS	VE	F	OE	SO	RTSO
MSB														LSB	

Bit	Notation	Meaning	Description
0	RTSO	Ready to switch on	Current state of the driver
1	SO	Switch on	
2	OE	Operation enabled	
3	F	Fault	
4	VE	Voltage enabled	
5	QS	Quick stop	
6	SOD	Switch on disabled	
7	W	Warning	0: No alarm occurred 1: Alarm occurred
8	DPRDY	Drive profile operation ready	0: Not ready for operation 1: Ready for operation
9	RM	Remote	0: Controlword is not processed. * 1: Controlword is processed.
10	TR	Target reached	Refer to following table.
11	ILA	Internal limit active	The internal limit is activated in the following cases: - The software limit was activated. - The FW-LS or RV-LS signal was activated. - The FW-BLK or RV-BLK signal was activated. - The STOP or QSTOP signal was activated. - The CLR signal was activated.
12	HA	Homing attained	Refer to following table.
13	HE	Homing error	
14	RSV	Reserved	Reserved
15	TLC	Torque limit control	The torque limit control is activated in the following cases: - The actual torque reaches the maximum output torque. - The actual torque reaches the torque limiting value.

* The Remote (bit 9) is "0" when any of the following conditions.

- The S-ON signal is active.
- Remote operation, data writing, or I/O test is executed with the support soft.

Homing error	Homing attained	Target reached	Description
Bit 13	Bit 12	Bit 10	
0	0	0	Homing procedure is in progress.
0	0	1	Homing procedure was interrupted or has not yet started.
0	1	0	Homing is attained, but the operation is still in progress.
0	1	1	Homing procedure was completed successfully.
1	0	0	A homing error occurred and the velocity is not 0.
1	0	1	A homing error occurred and the velocity is 0.
1	1	0	Reserved
1	1	1	

7.4.5 Homing method

The following homing methods are supported.

Homing method	Definition
1	Homing on negative limit switch and index pulse
2	Homing on positive limit switch and index pulse
8	Homing on home switch and index pulse and starting in the positive direction
12	Homing on home switch and index pulse and starting in the negative direction
17	Homing on negative limit switch
18	Homing on positive limit switch
24	Homing on home switch and starting in the positive direction
28	Homing on home switch and starting in the negative direction
35, 37 *	Homing on current position
-1	Homing method of Orientalmotor specifications. Refer to the following for details on the operations. - OPERATING MANUAL BLV Series R Type Function Edition

* 35 and 37 perform the same action

Note: The index pulse is the ZSG-N signal.

7.4.5.1 Method 1: Homing on negative limit switch and index pulse

In this method, homing starts in the negative direction if the negative limit switch is inactive. After the negative limit switch becomes inactive, the motor rotates to stop according to the value set in the "(HOME) Backward steps in 2 sensor homing (4169h)". The home position is the first index pulse that is detected after this moving.

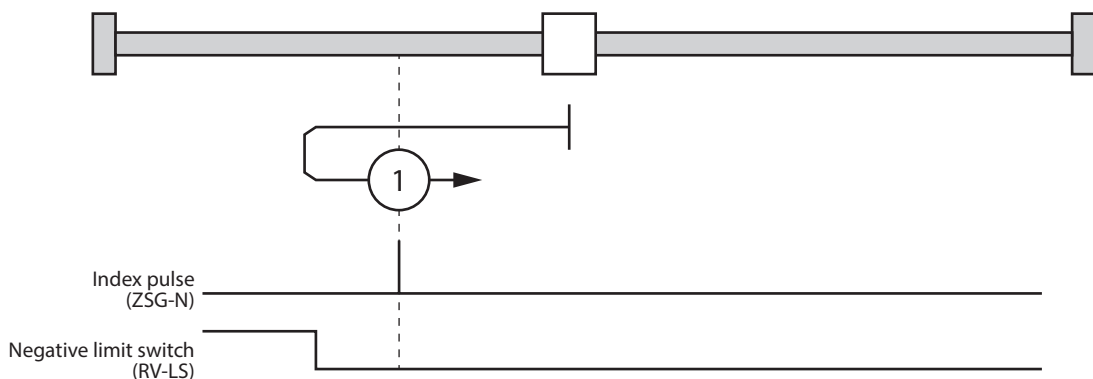

7.4.5.2 Method 2: Homing on positive limit switch and index pulse

In this method, homing starts in the positive direction if the positive limit switch is inactive. After the positive limit switch becomes inactive, the motor rotates to stop according to the value set in the "(HOME) Backward steps in 2 sensor homing (4169h)". The home position is the first index pulse that is detected after this moving.

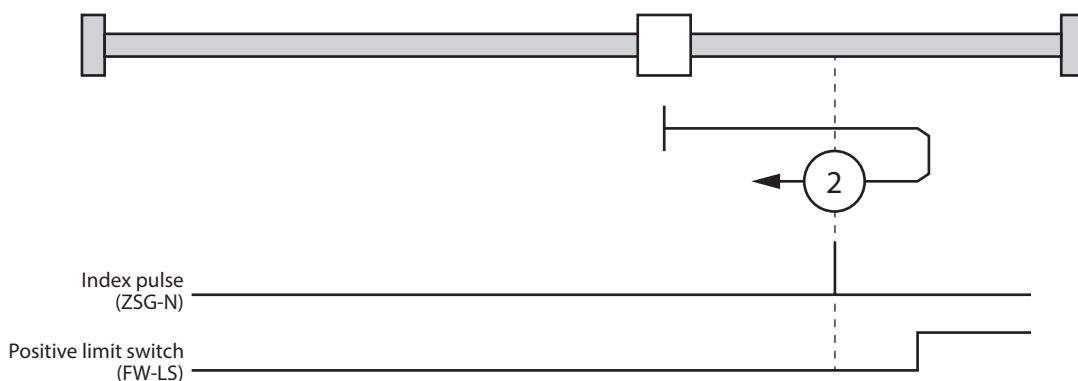

7.4.5.3 Method 8: Homing on home switch and index pulse and starting in the positive direction

In this method, homing starts in the positive direction.

However, if the home switch is already active when homing is started, the initial homing direction depends on the required edge. The home position will be the index pulse on the rising edge side of the home switch.

If the initial movement direction is away from the home switch, the motor will reverse direction when the limit switch in the movement direction is input.

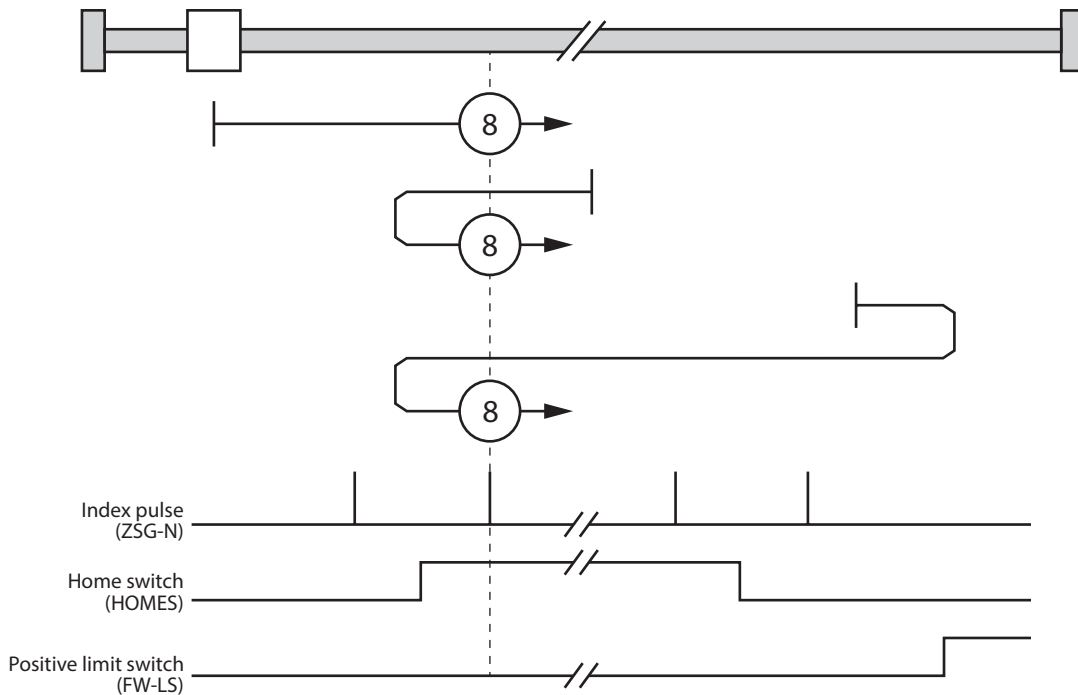

7.4.5.4 Method 12: Homing on home switch and index pulse and starting in the negative direction

In this method, homing starts in the negative direction.

However, if the home switch is already active when homing is started, the initial homing direction depends on the required edge. The home position will be the index pulse on the rising edge side of the home switch.

If the initial movement direction is away from the home switch, the motor will reverse direction when the limit switch in the movement direction is input.

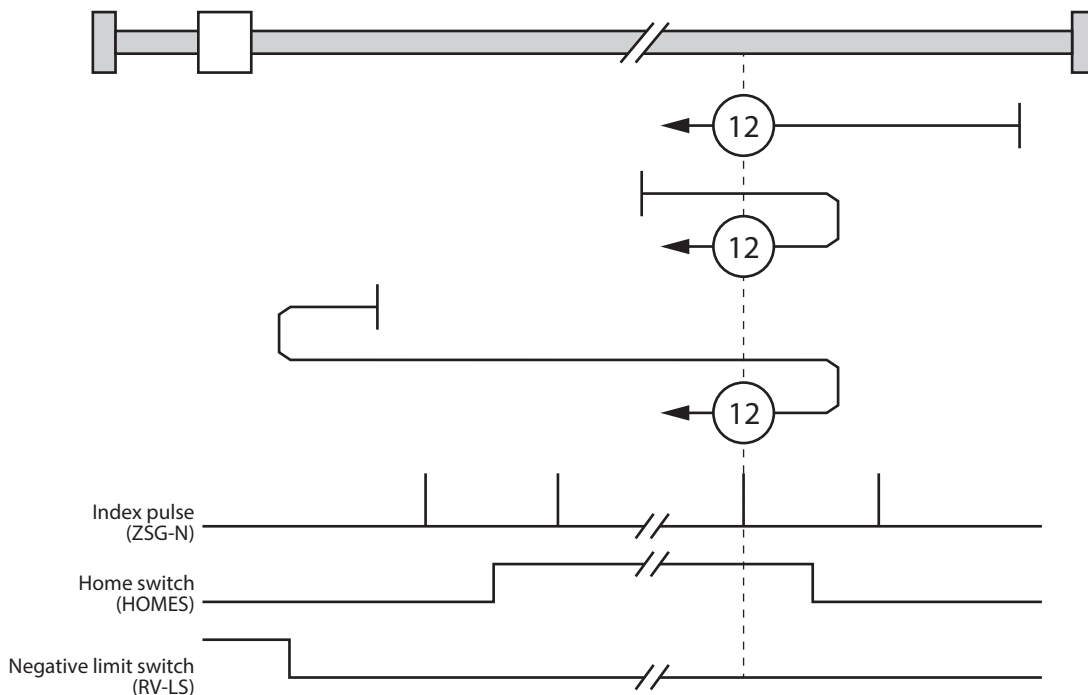

7.4.5.5 Method 17: Homing on negative limit switch

In this method, homing starts in the negative direction if the negative limit switch is inactive. After the negative limit switch becomes inactive, the motor rotates to stop according to the value set in the "(HOME) Backward steps in 2 sensor homing (4169h)." The stop position will be the home position.

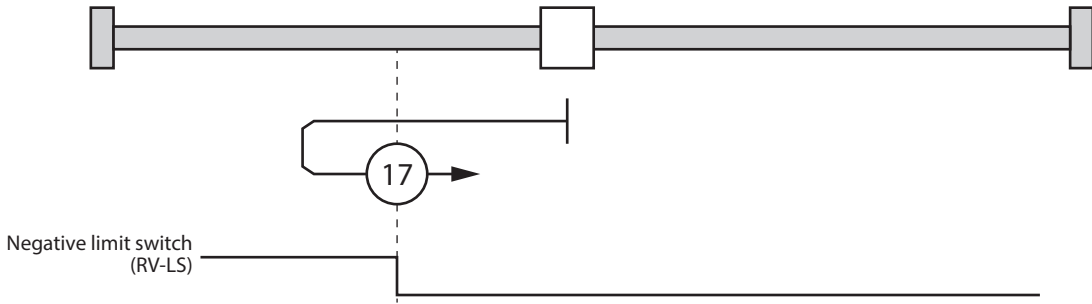

7.4.5.6 Method 18: Homing on positive limit switch

In this method, homing starts in the positive direction if the positive limit switch is inactive. After the positive limit switch becomes inactive, the motor rotates to stop according to the value set in the "(HOME) Backward steps in 2 sensor homing (4169h)." The stop position will be the home position.

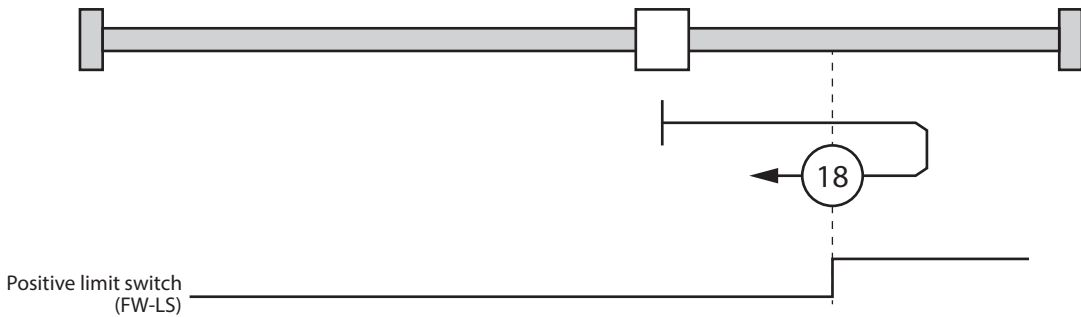

7.4.5.7 Method 24: Homing on home switch and starting in the positive direction

This method is same as method 8 except that the home position does not depend on the index pulse. Here, it depends only on changes in the relevant home switch (HOMES) or limit switch (FW-LS).

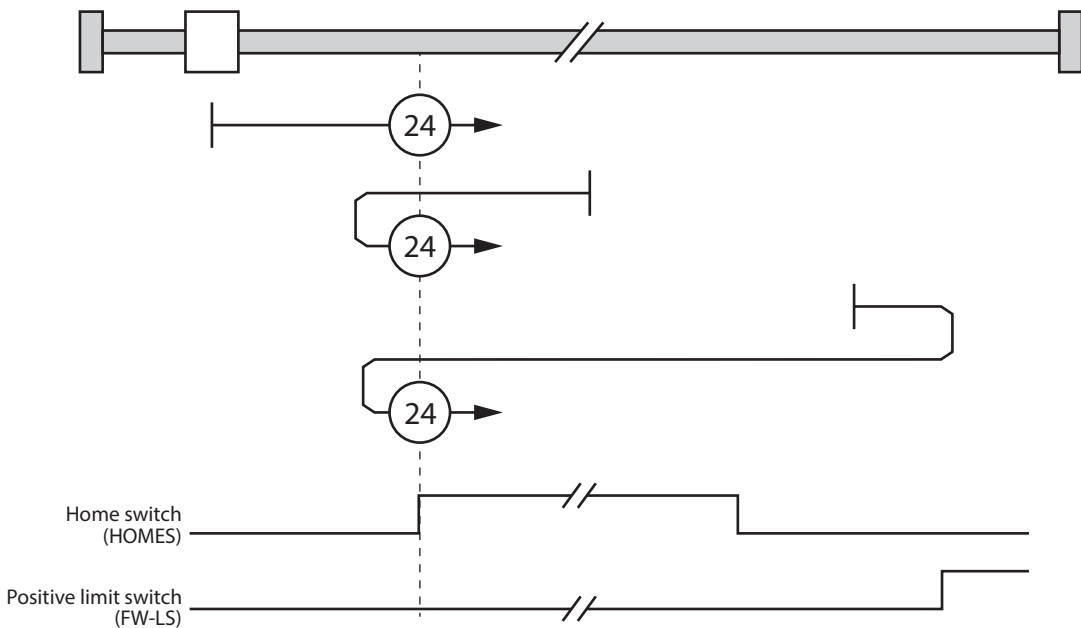

7.4.5.8 Method 28: Homing on home switch and starting in the negative direction

This method is same as method 12 except that the home position does not depend on the index pulse. Here, it depends only on changes in the relevant home switch (HOMES) or limit switch (RV-LS).

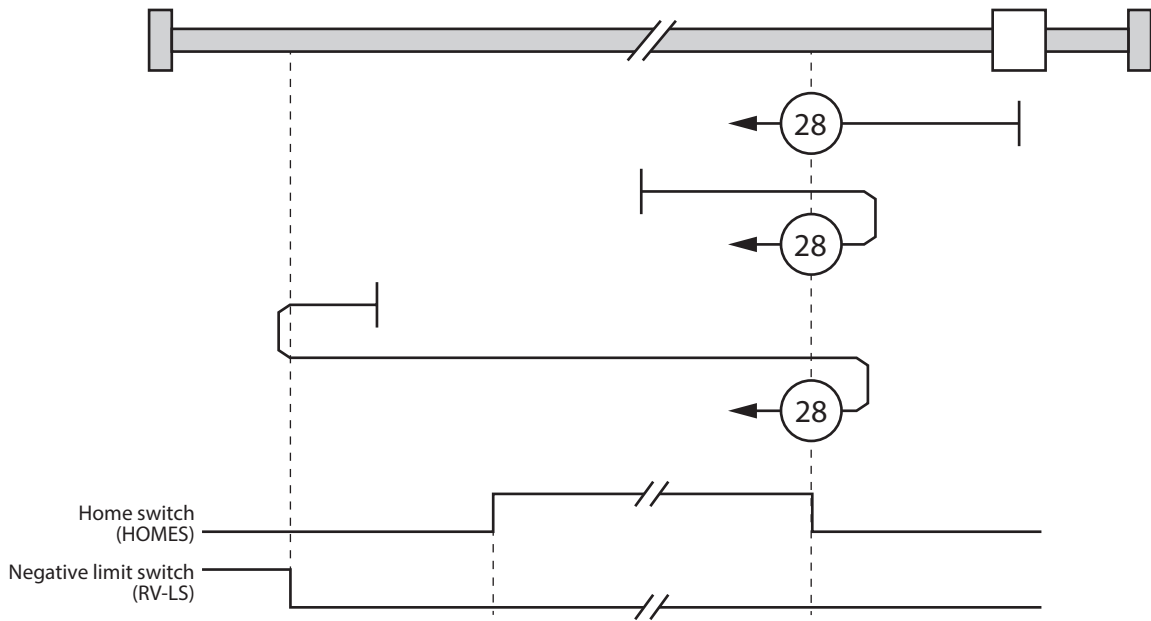

7.4.5.9 Method 35, 37: Homing on current position

In this method, the current position is defined as the home position. You can execute this method even if the drive device is not in the Operation Enabled state.

7.5 Touch probe functionality

7.5.1 General Information

You can latch the actual position with the following trigger events.

- Trigger with probe 1 input (USR-LAT-IN0 input signal)
- Trigger with probe 2 input (USR-LAT-IN1 input signal)
- Trigger with ZSG-N output signal

Note: The trigger events must be active for 1 ms or more.

7.5.2 Related Objects

Index	Sub-index	Name	Type	Access	PDO mapping	Unit (default)
60B8h	00h	Touch probe function	UINT16	rww	Yes	–
60B9h	00h	Touch probe status	UINT16	ro	Yes	–
60BAh	00h	Touch probe 1 positive edge	INT32	ro	Yes	Pos. unit (step)
60BBh	00h	Touch probe 1 negative edge	INT32	ro	Yes	Pos. unit (step)
60BC h	00h	Touch probe 2 positive edge	INT32	ro	Yes	Pos. unit (step)
60BDh	00h	Touch probe 2 negative edge	INT32	ro	Yes	Pos. unit (step)
60D5h	00h	Touch probe 1 positive edge counter	UINT16	ro	Yes	–
60D6h	00h	Touch probe 1 negative edge counter	UINT16	ro	Yes	–
60D7h	00h	Touch probe 2 positive edge counter	UINT16	ro	Yes	–
60D8h	00h	Touch probe 2 negative edge counter	UINT16	ro	Yes	–

7.5.3 Example of Execution Procedure for a Touch Probe

The operation examples of touch probe 1 are shown below.

Trigger first event

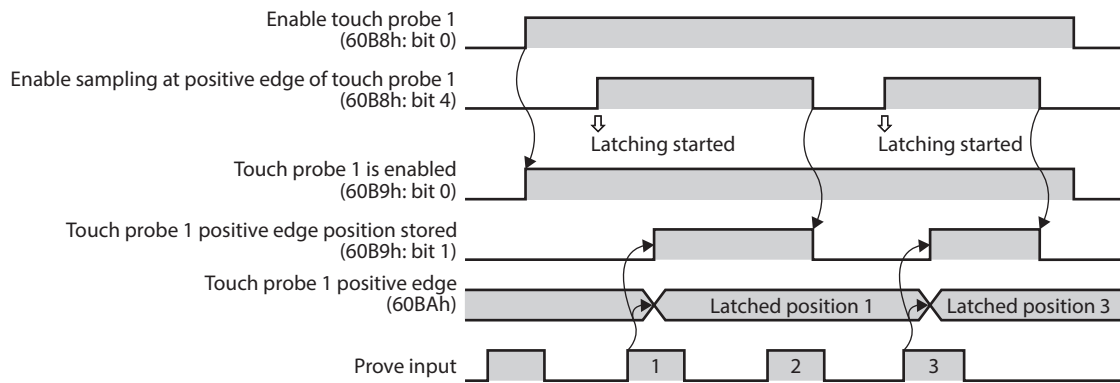

Continuous

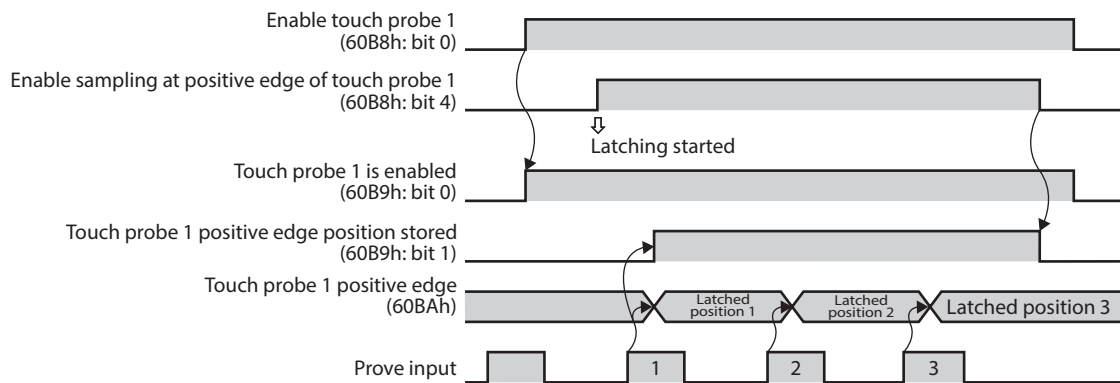

8 Object Dictionary

8.1 Communication Objects

- **1000h: Device Type**

This object contains the device type and functionality.

Index	Sub-index	Name	Data type	Access	PDO	Value (Default)	Unit	Save
1000h	00h	Device type	UINT32	c	No	0002 0192h	–	No

Data Description

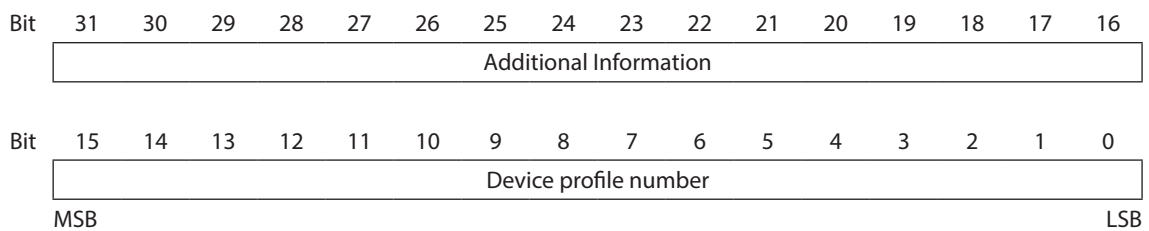

Additional Information: 2 (0002h) Servo Drive (Brushless motor driver)

Device profile number: 402 (0192h) DS402 drive profile

- **1001h: Error register**

If an error bit is set in the manufacturer independent error register, then more detailed information is made available in "Pre-defined error field (1003h)".

This object is part of the Error Object (Emergency Message). ⇨ "4.5 Emergency object (EMCY)"

Index	Sub-index	Name	Data type	Access	PDO	Value (Default)	Unit	Save
1001h	00h	Error register	UINT8	ro	No	–	–	No

Data Description

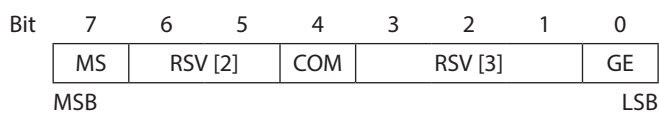

Bit	Notation	Meaning
0	GE	Generic error
1 to 3	RSV	Reserved
4	COM	Communication error
5, 6	RSV	Reserved
7	MS	Manufacturer-specific error

● 1003h: Pre-defined error field

This object contains an error record with up to ten entries.

- The value in Sub-index 00h shows the number of recorded errors.
- The most recent error is shown in Sub-index 01h.
- The error number has the data type UINT32 and is composed of a 16-bit error code and an additional information field. The additional information field is not used by this driver.

Note: If no error is present, the value of sub-index 00h is 00h and a read access to sub-index 01h is responded with an SDO abort message (abort code: 0800 0024h).

Index	Sub-index	Name	Data type	Access	PDO	Value (Default)	Unit	Save
1003h	Pre-defined error field							
	00h	Number of errors	UINT8	rw	No	0	–	No
	01h	Standard error field 1	UINT32	ro	No	(–)	–	No
	02h	Standard error field 2	UINT32	ro	No	(–)	–	No
	03h	Standard error field 3	UINT32	ro	No	(–)	–	No
	04h	Standard error field 4	UINT32	ro	No	(–)	–	No
	05h	Standard error field 5	UINT32	ro	No	(–)	–	No
	06h	Standard error field 6	UINT32	ro	No	(–)	–	No
	07h	Standard error field 7	UINT32	ro	No	(–)	–	No
	08h	Standard error field 8	UINT32	ro	No	(–)	–	No
	09h	Standard error field 9	UINT32	ro	No	(–)	–	No
0Ah	Standard error field 10	UINT32	ro	No	(–)	–	No	

Data Description

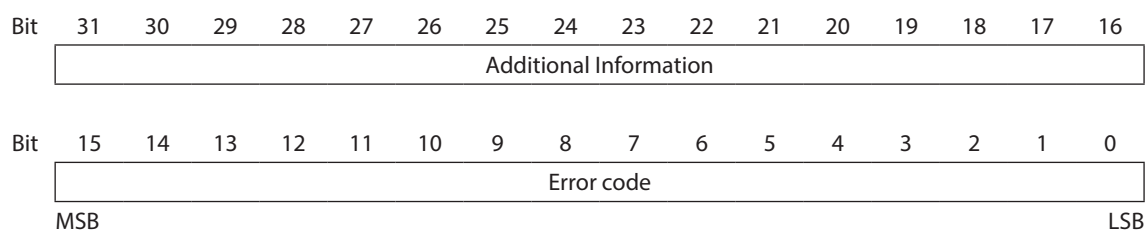

Additional Information: 0 (0000h)

Error code: Refer to "4.5 Emergency object (EMCY)"

- **1005h: COB-ID SYNC message**

This object can be used to change the COB-ID for the SYNC message.
Further, it defines whether the driver generates the SYNC.

Index	Sub-index	Name	Data type	Access	PDO	Value (Default)	Unit	Save
1005h	00h	COB-ID SYNC message	UINT32	rw	No	0000 0000h to FFFF FFFFh (0000 0080h)	–	Yes

Data Description

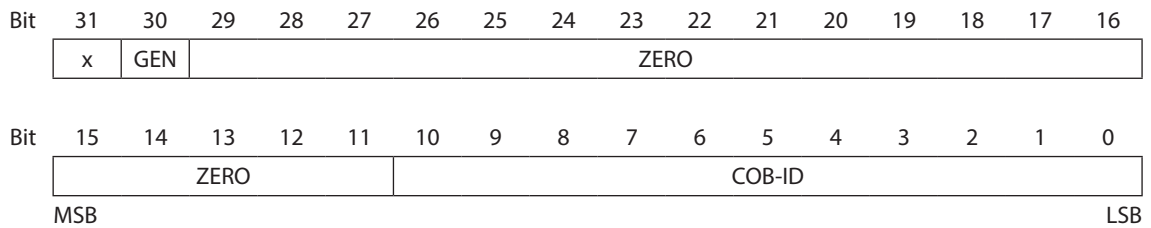

Bit	Notation	Meaning
0 to 10	COB-ID	11-bit COB-ID
11 to 29	ZERO	Set to "0"
30	GEN	0: The driver does not generate SYNC message. 1: The driver generate SYNC message.
31	x	Do not care.

- **1006h: Communication cycle period**

This object can be used to define the cycle period (in μs) for the SYNC interval. Only multiples of 250 μs are permitted.

Index	Sub-index	Name	Data type	Access	PDO	Value (Default)	Unit	Save
1006h	00h	Communication cycle period	UINT32	rw	No	0 to 1,000,000 (0)	μs	Yes

- **1008h: Manufacturer device name**

This object contains the device name as character string.

Index	Sub-index	Name	Data type	Access	PDO	Value (Default)	Unit	Save
1008h	00h	Manufacturer device name	STRING	c	No	BLVD-KRD	–	No

- **1009h: Manufacturer hardware version**

This object contains the hardware version as character string. "Rev.1.00" is indicated when the version is 1.00.

Index	Sub-index	Name	Data type	Access	PDO	Value (Default)	Unit	Save
1009h	00h	Manufacturer hardware version	STRING	c	No	Hardware version	–	No

- **100Ah: Manufacturer software version**

This object contains the software version as character string. "V.1.00" is indicated when the version is 1.00.

Index	Sub-index	Name	Data type	Access	PDO	Value (Default)	Unit	Save
100Ah	00h	Manufacturer software version	STRING	c	No	Software version	–	No

- **100Ch: Guard time**

The objects at "Guard time (100Ch)" and "Life time factor (100Dh)" indicate the configured guard time respectively the life time factor. The life time factor multiplied with the guard time provides the life time for the node guarding protocol. The value is specified in milliseconds.

If the value of the Object "Guard time" is set to "0", then disable the node guarding.

Index	Sub-index	Name	Data type	Access	PDO	Value (Default)	Unit	Save
100Ch	00h	Guard time	UINT16	rw	No	0 to 65,535 (0)	ms	Yes

- **100Dh: Life time factor**

The life time factor multiplied with the guard time provides the life time for the node guarding protocol.

If the value of the Object "Life time factor" is set to "0", then disable the node guarding.

Index	Sub-index	Name	Data type	Access	PDO	Value (Default)	Unit	Save
100Dh	00h	Life time factor	UINT8	rw	No	0 to 255 (0)	–	Yes

● 1010h: Store parameters

You can use this object to save the parameter settings in non-volatile memory.

Index	Sub-index	Name	Data type	Access	PDO	Value (Default)	Unit	Save
1010h	Store parameters							
	00h	Highest sub-index supported	UINT8	ro	No	2	-	No
	01h	Save all parameters	UINT32	rw	No	0000 0000h to FFFF FFFFh (0000 0000h)	-	No
	02h	Save communication parameters	UINT32	rw	No	0000 0000h to FFFF FFFFh (0000 0000h)	-	No

To prevent saving parameters by mistake, they are saved only when a specific signature is written to the appropriate sub-index. The signature is "save."

Signature	MSB		LSB	
character	e	v	a	s
hex	65h	76h	61h	73h

If you write "save" to sub-index 1, all parameters are saved.

If you write "save" to sub-index 2, the communications parameters (objects from 1000h to 1FFFh) are saved.

On reception of the correct signature in the appropriate sub-index the driver stores the parameter and then it confirms the SDO transmission (SDO download initiate response).

If the storing failed, the driver responds with the SDO abort transfer service (abort code: 0606 0000h).

If a wrong signature is written, the driver refuse to store and it responds with the SDO abort transfer service (abort code: 0800 002xh).

On read access to the appropriate sub-index the driver provides information about its storage functionality with the following format.

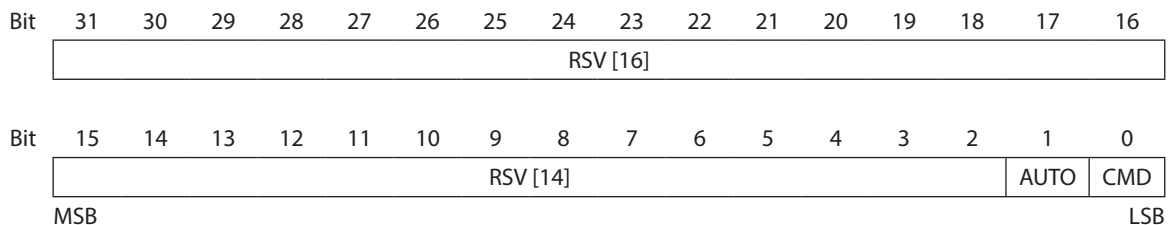

Bit	Notation	Meaning
0	CMD	Always 1: The driver saves parameters on command.
1	AUTO	Always 0
2 to 31	RSV	Reserved

Note: Autonomous saving means that a driver stores the storable parameters in a non-volatile memory without user request.

● 1011h: Restore default parameters

You can use this object to restore the parameters to the default values.

Index	Sub-index	Name	Data type	Access	PDO	Value (Default)	Unit	Save
1011h	Restore default parameters							
	00h	Highest sub-index supported	UINT8	ro	No	2	–	No
	01h	Restore all default parameters	UINT32	rw	No	0000 0000h to FFFF FFFFh (0000 0000h)	–	No
	02h	Restore communication default parameters	UINT32	rw	No	0000 0000h to FFFF FFFFh (0000 0000h)	–	No

To prevent restoring the parameters to the default values by mistake, the parameters are restored to the default values only when a specific signature is written to the appropriate sub-index. The signature is “load.”

Signature character	MSB		LSB	
	hex	d	a	o
	64h	61h	6Fh	6Ch

If you write “load” to sub-index 1, all parameters are restored to the default values.

If you write “load” to sub-index 2, the communications parameters (objects from 1000h to 1FFFh) are restored to the default values.

On reception of the correct signature in the appropriate sub-index the driver restores the default parameters and then it confirms the SDO transmission (SDO download initiate response).

If the restoring failed, the driver responds with the SDO abort transfer service (abort code: 0606 0000h).

If a wrong signature is written, the driver refuses to restore the defaults and responds with the SDO abort transfer service (abort code: 0800 002xh).

The default values will be set valid after the driver is reset (NMT service reset node for sub-index from 01h to 7Fh, NMT service reset communication for sub-index 02h) or power cycled.

On read access to the appropriate sub-index the driver provides information about its default parameter restoring capability with the following format.

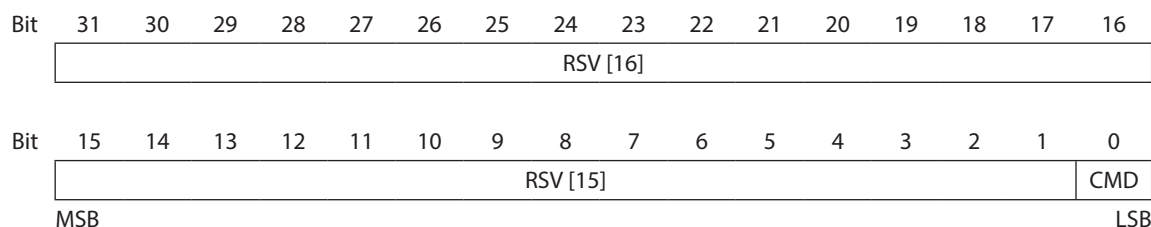

Bit	Notation	Meaning
0	CMD	Always 1: The driver restores parameters.
1 to 31	RSV	Reserved

- **1014h: COB-ID EMCY**

This object can be used to define the COB-ID for the Emergency message.

Index	Sub-index	Name	Data type	Access	PDO	Value (Default)	Unit	Save
1014h	00h	COB-ID EMCY	UINT32	rw	No	80h + Node-ID	-	Yes

Data Description

Bit	31	30	29	28	27	26	25	24	23	22	21	20	19	18	17	16
	VALID		ZERO													
Bit	15	14	13	12	11	10	9	8	7	6	5	4	3	2	1	0
	ZERO						11bit-Node-ID									
	MSB															LSB

Bit	Notation	Meaning
0 to 10	Node-ID	11-bit Node-ID
11 to 30	ZERO	Set to "0"
31	VALID	0: EMCY exists / is valid 1: EMCY does not exist / is not valid

- **1016h: Consumer heartbeat time**

This object defines the cycle time of the Consumer Heartbeat of the Network Management CANopen service and the Node-ID of the Producer of the Heartbeat.

Index	Sub-index	Name	Data type	Access	PDO	Value (Default)	Unit	Save
1016h	Consumer heartbeat time							
	00h	Highest sub-index supported	UINT8	ro	No	1	-	No
	01h	Consumer heartbeat time	UINT32	rw	No	0000 0000h to 00FF FFFFh (0000 0000h)	-	Yes

Data Description of Sub-index 01h

Bit	31	30	29	28	27	26	25	24	23	22	21	20	19	18	17	16
	ZERO						Node-ID									
Bit	15	14	13	12	11	10	9	8	7	6	5	4	3	2	1	0
	Heartbeat time															
	MSB															LSB

Bit	Notation	Meaning
0 to 15	Heartbeat time	The time of the Consumer Heartbeat in millisecond.
16 to 23	Node-ID	The Node-ID of the Producer whose Heartbeat is to be monitored.
24 to 31	ZERO	Set to "0"

- **1017h: Producer heartbeat time**

This object defines the cycle time of the Heartbeat of the Network Management CANopen service in milliseconds.

Index	Sub-index	Name	Data type	Access	PDO	Value (Default)	Unit	Save
1017h	00h	Producer heartbeat time	UINT16	rw	No	0 to 65,535 (0)	ms	Yes

- **1018h: Identity object**

This object contains general information on the driver.

Index	Sub-index	Name	Data type	Access	PDO	Value (Default)	Unit	Save
1018h	Identity object							
	00h	Highest sub-index supported	UINT8	ro	No	2	-	No
	01h	Vender ID	UINT32	ro	No	0000 02BEh	-	No
	02h	Product code	UINT32	ro	No	0000 13F7h	-	No

- **1200h: SDO server parameter**

This object is the COB-ID for SDO server.

Index	Sub-index	Name	Data type	Access	PDO	Value (Default)	Unit	Save
1200h	SDO server parameter							
	00h	Highest sub-index supported	UINT8	ro	No	2	-	No
	01h	COB-ID client -> server (rx)	UINT32	ro	No	600h + Node-ID	-	No
	02h	COB-ID server -> client (tx)	UINT32	ro	No	580h + Node-ID	-	No

● **1400h: 1st RPDO communication parameter**

This object contains the communication parameters for the PDOs that the driver is able to receive. (RPDO1)

Index	Sub-index	Name	Data type	Access	PDO	Value (Default)	Unit	Save
1400h	1st RPDO communication parameter							
	00h	Highest sub-index supported	UINT8	ro	No	2	-	No
	01h	COB-ID used by RPDO	UINT32	rw	No	0000 0000h to FFFF FFFFh (200h + Node-ID)	-	Yes
	02h	Transmission type	UINT8	rw	No	0 to 255 (255)	-	Yes

Data Description of Sub-index 01h

Bit	31	30	29	28	27	26	25	24	23	22	21	20	19	18	17	16																
	VALID		ZERO																													
Bit	15	14	13	12	11	10	9	8	7	6	5	4	3	2	1	0																
	ZERO						COB-ID																									
	MSB																LSB															

Bit	Notation	Meaning
0 to 10	COB-ID	11-bit COB-ID
11 to 30	ZERO	Set to "0"
31	VALID	0: PDO exists / is valid 1: PDO does not exist / is not valid

Data Description of Sub-index 02h

Value	Description
00h	Synchronous If the transmission type of RPDO is set to synchronous, the received PDO data will be pending then updated on the next reception of the SYNC object.
FEh	event-driven (manufacturer-specific) If the transmission type of RPDO is set to event-driven (manufacturer-specific), the received PDO data will be updated immediately. The driver executes the following contents when received data in this transmission type. - The driver Issue RTR to the corresponding TPDO - The driver reset the node lifetime
FFh	event-driven If the transmission type of RPDO is set to event-driven, the received PDO data will be updated immediately.

Sub-index 02h defines the reception character of the RPDO. An attempt to change the value of the transmission type to any not supported value will be responded with the SDO abort transfer service (abort code: 0609 0030h).

● **1401h: 2nd RPDO communication parameter**

This object contains the communication parameters for the PDOs that the driver is able to receive. (RPDO2)

Index	Sub-index	Name	Data type	Access	PDO	Value (Default)	Unit	Save
1401h	2nd RPDO communication parameter							
	00h	Highest sub-index supported	UINT8	ro	No	2	-	No
	01h	COB-ID used by RPDO	UINT32	rw	No	0000 0000h to FFFF FFFFh (300h + Node-ID)	-	Yes
	02h	Transmission type	UINT8	rw	No	0 to 255 (255)	-	Yes

Data Description of Sub-index 01h

Bit	31	30	29	28	27	26	25	24	23	22	21	20	19	18	17	16																
	VALID		ZERO																													
Bit	15	14	13	12	11	10	9	8	7	6	5	4	3	2	1	0																
	ZERO						COB-ID																									
	MSB																LSB															

Bit	Notation	Meaning
0 to 10	COB-ID	11-bit COB-ID
11 to 30	ZERO	Set to "0"
31	VALID	0: PDO exists / is valid 1: PDO does not exist / is not valid

Data Description of Sub-index 02h

Value	Description
00h	Synchronous If the transmission type of RPDO is set to synchronous, the received PDO data will be pending then updated on the next reception of the SYNC object.
FEh	event-driven (manufacturer-specific) If the transmission type of RPDO is set to event-driven (manufacturer-specific), the received PDO data will be updated immediately. The driver executes the following contents when received data in this transmission type. - The driver Issue RTR to the corresponding TPDO - The driver reset the node lifetime
FFh	event-driven If the transmission type of RPDO is set to event-driven, the received PDO data will be updated immediately.

Sub-index 02h defines the reception character of the RPDO. An attempt to change the value of the transmission type to any not supported value will be responded with the SDO abort transfer service (abort code: 0609 0030h).

● **1402h: 3rd RPDO communication parameter**

This object contains the communication parameters for the PDOs that the driver is able to receive. (RPDO3)

Index	Sub-index	Name	Data type	Access	PDO	Value (Default)	Unit	Save
1402h	3rd RPDO communication parameter							
	00h	Highest sub-index supported	UINT8	ro	No	2	-	No
	01h	COB-ID used by RPDO	UINT32	rw	No	0000 0000h to FFFF FFFFh (400h + Node-ID)	-	Yes
	02h	Transmission type	UINT8	rw	No	0 to 255 (255)	-	Yes

Data Description of Sub-index 01h

Bit	31	30	29	28	27	26	25	24	23	22	21	20	19	18	17	16	
	VALID		ZERO														
Bit	15	14	13	12	11	10	9	8	7	6	5	4	3	2	1	0	
	ZERO						COB-ID										
	MSB																LSB

Bit	Notation	Meaning
0 to 10	COB-ID	11-bit COB-ID
11 to 30	ZERO	Set to "0"
31	VALID	0: PDO exists / is valid 1: PDO does not exist / is not valid

Data Description of Sub-index 02h

Value	Description
00h	Synchronous If the transmission type of RPDO is set to synchronous, the received PDO data will be pending then updated on the next reception of the SYNC object.
FEh	event-driven (manufacturer-specific) If the transmission type of RPDO is set to event-driven (manufacturer-specific), the received PDO data will be updated immediately. The driver executes the following contents when received data in this transmission type. - The driver Issue RTR to the corresponding TPDO - The driver reset the node lifetime
FFh	event-driven If the transmission type of RPDO is set to event-driven, the received PDO data will be updated immediately.

Sub-index 02h defines the reception character of the RPDO. An attempt to change the value of the transmission type to any not supported value will be responded with the SDO abort transfer service (abort code: 0609 0030h).

● **1403h: 4nd RPDO communication parameter**

This object contains the communication parameters for the PDOs that the driver is able to receive. (RPDO4)

Index	Sub-index	Name	Data type	Access	PDO	Value (Default)	Unit	Save
1403h	3rd RPDO communication parameter							
	00h	Highest sub-index supported	UINT8	ro	No	2	-	No
	01h	COB-ID used by RPDO	UINT32	rw	No	0000 0000h to FFFF FFFFh (500h + Node-ID)	-	Yes
	02h	Transmission type	UINT8	rw	No	0 to 255 (255)	-	Yes

Data Description of Sub-index 01h

Bit	31	30	29	28	27	26	25	24	23	22	21	20	19	18	17	16																
	VALID		ZERO																													
Bit	15	14	13	12	11	10	9	8	7	6	5	4	3	2	1	0																
	ZERO						COB-ID																									
	MSB																LSB															

Bit	Notation	Meaning
0 to 10	COB-ID	11-bit COB-ID
11 to 30	ZERO	Set to "0"
31	VALID	0: PDO exists / is valid 1: PDO does not exist / is not valid

Data Description of Sub-index 02h

Value	Description
00h	Synchronous If the transmission type of RPDO is set to synchronous, the received PDO data will be pending then updated on the next reception of the SYNC object.
FEh	event-driven (manufacturer-specific) If the transmission type of RPDO is set to event-driven (manufacturer-specific), the received PDO data will be updated immediately. The driver executes the following contents when received data in this transmission type. - The driver Issue RTR to the corresponding TPDO - The driver reset the node lifetime
FFh	event-driven If the transmission type of RPDO is set to event-driven, the received PDO data will be updated immediately.

Sub-index 02h defines the reception character of the RPDO. An attempt to change the value of the transmission type to any not supported value will be responded with the SDO abort transfer service (abort code: 0609 0030h).

● **1600h: 1st RPDO mapping parameter**

This object contains the mapping parameters for the PDOs the driver is able to receive. (RPDO1)

Index	Sub-index	Name	Data type	Access	PDO	Value (Default)	Unit	Save
1600h	1st RPDO mapping parameter							
	00h	Number of mapped application objects in PDO	UINT8	rw	No	1	-	Yes
	01h	1st application object	UINT32	rw	No	0000 0000h to FFFF FFFFh (6040 0010h)	-	Yes
	02h	2nd application object	UINT32	rw	No	0000 0000h to FFFF FFFFh (0000 0000h)	-	Yes
	03h	3rd application object	UINT32	rw	No	0000 0000h to FFFF FFFFh (0000 0000h)	-	Yes
	04h	4th application object	UINT32	rw	No	0000 0000h to FFFF FFFFh (0000 0000h)	-	Yes

Data Description of Sub-index 01h to 04h

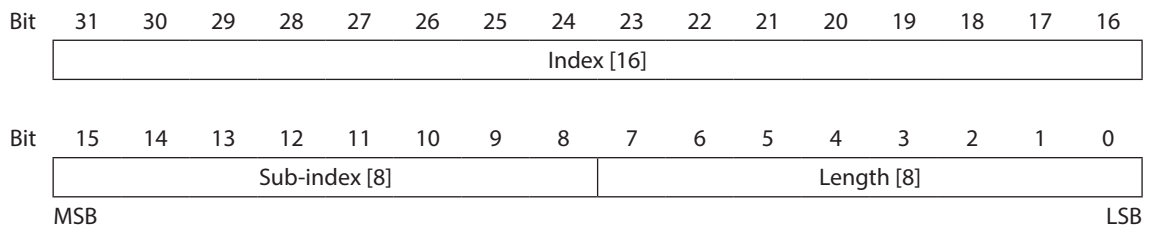

Bit	Notation	Meaning
0 to 7	Length	This contains the length of the object to be mapped in units of bits.
8 to 15	Sub-index	This contains the sub-index of the object to be mapped.
16 to 31	Index	This contains the index of the object to be mapped.

- **1601h: 2nd RPDO mapping parameter**

This object contains the mapping parameters for the PDOs the driver is able to receive. (RPDO2)

Index	Sub-index	Name	Data type	Access	PDO	Value (Default)	Unit	Save
1601h	2nd RPDO mapping parameter							
	00h	Number of mapped application objects in PDO	UINT8	rw	No	2	–	Yes
	01h	1st application object	UINT32	rw	No	0000 0000h to FFFF FFFFh (6040 0010h)	–	Yes
	02h	2nd application object	UINT32	rw	No	0000 0000h to FFFF FFFFh (6060 0008h)	–	Yes
	03h	3rd application object	UINT32	rw	No	0000 0000h to FFFF FFFFh (0000 0000h)	–	Yes
	04h	4th application object	UINT32	rw	No	0000 0000h to FFFF FFFFh (0000 0000h)	–	Yes

Data Description of Sub-index 01h to 04h

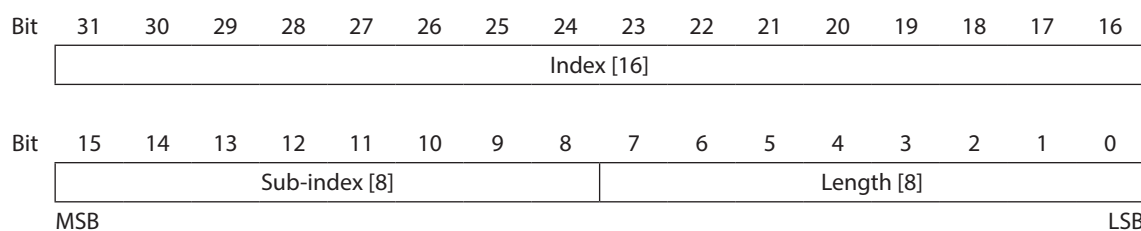

Bit	Notation	Meaning
0 to 7	Length	This contains the length of the object to be mapped in units of bits.
8 to 15	Sub-index	This contains the sub-index of the object to be mapped.
16 to 31	Index	This contains the index of the object to be mapped.

- **1602h: 3rd RPDO mapping parameter**

This object contains the mapping parameters for the PDOs the driver is able to receive. (RPDO3)

Index	Sub-index	Name	Data type	Access	PDO	Value (Default)	Unit	Save
1602h	3rd RPDO mapping parameter							
	00h	Number of mapped application objects in PDO	UINT8	rw	No	2	–	Yes
	01h	1st application object	UINT32	rw	No	0000 0000h to FFFF FFFFh (6040 0010h)	–	Yes
	02h	2nd application object	UINT32	rw	No	0000 0000h to FFFF FFFFh (607A 0020h)	–	Yes
	03h	3rd application object	UINT32	rw	No	0000 0000h to FFFF FFFFh (0000 0000h)	–	Yes
	04h	4th application object	UINT32	rw	No	0000 0000h to FFFF FFFFh (0000 0000h)	–	Yes

Data Description of Sub-index 01h to 04h

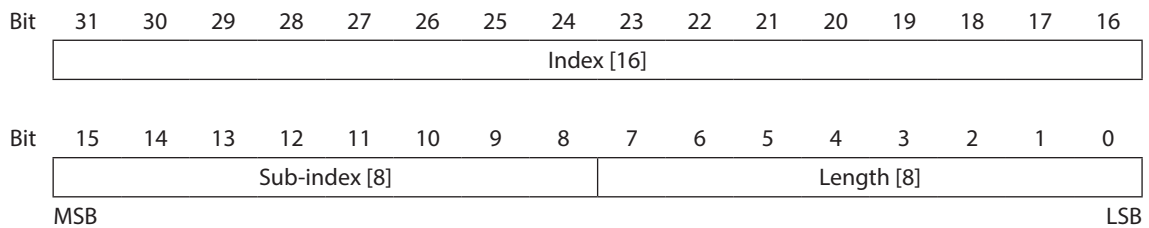

Bit	Notation	Meaning
0 to 7	Length	This contains the length of the object to be mapped in units of bits.
8 to 15	Sub-index	This contains the sub-index of the object to be mapped.
16 to 31	Index	This contains the index of the object to be mapped.

- **1603h: 4th RPDO mapping parameter**

This object contains the mapping parameters for the PDOs the driver is able to receive. (RPDO4)

Index	Sub-index	Name	Data type	Access	PDO	Value (Default)	Unit	Save
1603h	4th RPDO mapping parameter							
	00h	Number of mapped application objects in PDO	UINT8	rw	No	2	–	Yes
	01h	1st application object	UINT32	rw	No	0000 0000h to FFFF FFFFh (6040 0010h)	–	Yes
	02h	2nd application object	UINT32	rw	No	0000 0000h to FFFF FFFFh (60FF 0020h)	–	Yes
	03h	3rd application object	UINT32	rw	No	0000 0000h to FFFF FFFFh (0000 0000h)	–	Yes
	04h	4th application object	UINT32	rw	No	0000 0000h to FFFF FFFFh (0000 0000h)	–	Yes

Data Description of Sub-index 01h to 04h

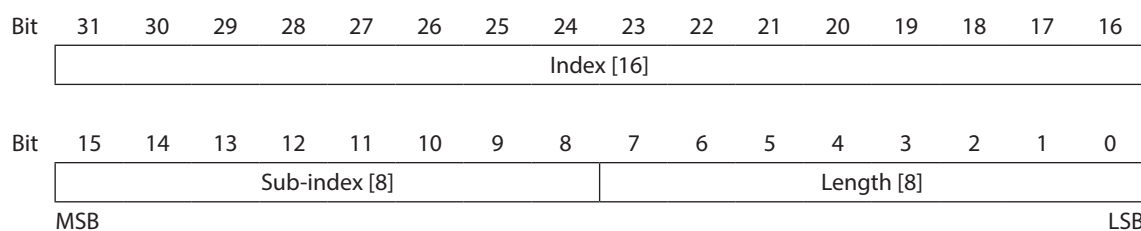

Bit	Notation	Meaning
0 to 7	Length	This contains the length of the object to be mapped in units of bits.
8 to 15	Sub-index	This contains the sub-index of the object to be mapped.
16 to 31	Index	This contains the index of the object to be mapped.

- **1800h: 1st TPDO communication parameter**

This object contains the communication parameters for the PDOs the driver is able to transmit. (TPDO1)

Index	Sub-index	Name	Data type	Access	PDO	Value (Default)	Unit	Save
1800h	1st TPDO communication parameter							
	00h	Highest sub-index supported	UINT8	ro	No	5	–	No
	01h	COB-ID used by TPDO	UINT32	rw	No	0000 0000h to FFFF FFFFh (4000 0180h + Node-ID)	–	Yes
	02h	Transmission type	UINT8	rw	No	0 to 255 (255)	–	Yes
	03h	Inhibit time	UINT16	rw	No	0 to 65,535 (50)	100 µs	Yes
	04h	Reserved	–	–	–	–	–	–
	05h	Event timer	UINT16	rw	No	0 to 65,535 (0)	ms	Yes

Data Description of Sub-index 01h

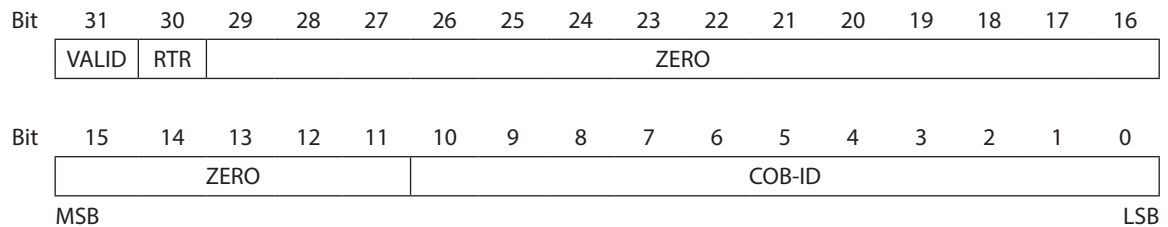

Bit	Notation	Meaning
0 to 10	COB-ID	11-bit COB-ID
11 to 29	ZERO	Set to "0"
30	RTR	0: RTR allowed on this PDO 1: no RTR allowed on this PDO
31	VALID	0: PDO exists / is valid 1: PDO does not exist / is not valid

Sub-index 02h defines the transmission character of the TPDO. An attempt to change the value of the transmission type to any not supported value is responded with the SDO abort transfer service (abort code: 0609 0030h).

Data Description of Sub-index 02h

Value	Description
00h	synchronous (acyclic)
01h	synchronous (cyclic every SYNC)
02h	synchronous (cyclic every 2nd SYNC)
03h	synchronous (cyclic every 3rd SYNC)
:	:
:	:
F0h	synchronous (cyclic every 240th SYNC)
F1h to FBh	Reserved
FCh	RTR-only (synchronous)
FDh	RTR-only (event-driven)
FEh	event-driven
FFh	event-driven

Sub-index 03h contains the inhibit time. The time is the minimum interval for PDO transmission if the transmission type is set to FEh and FFh. The value is defined as multiple of 100 microseconds.

The value of 0 is disable the inhibit time.

The value shall not be changed while the PDO exists (bit 31 of sub-index 01h is set to 0b).

Sub-index 04h is reserved. It does shall not be implemented; in this case read or write access leads to the SDO abort transfer service (abort code: 0609 0011h).

Sub-index 05h contains the event-timer. The time is the maximum interval for PDO transmission if the transmission type is set to FEh and FFh.

The value is defined as multiple of 1 millisecond. The value of 0 is disable the event-timer.

- **1801h: 2nd TPDO communication parameter**

This object contains the communication parameters for the PDOs the driver is able to transmit. (TPDO2)

Index	Sub-index	Name	Data type	Access	PDO	Value (Default)	Unit	Save
1801h	2nd TPDO communication parameter							
	00h	Highest sub-index supported	UINT8	ro	No	5	-	No
	01h	COB-ID used by TPDO	UINT32	rw	No	0000 0000h to FFFF FFFFh (4000 0280h + Node-ID)	-	Yes
	02h	Transmission type	UINT8	rw	No	0 to 255 (255)	-	Yes
	03h	Inhibit time	UINT16	rw	No	0 to 65,535 (50)	100 µs	Yes
	04h	Reserved	-	-	-	-	-	-
	05h	Event timer	UINT16	rw	No	0 to 65,535 (0)	ms	Yes

Data Description of Sub-index 01h

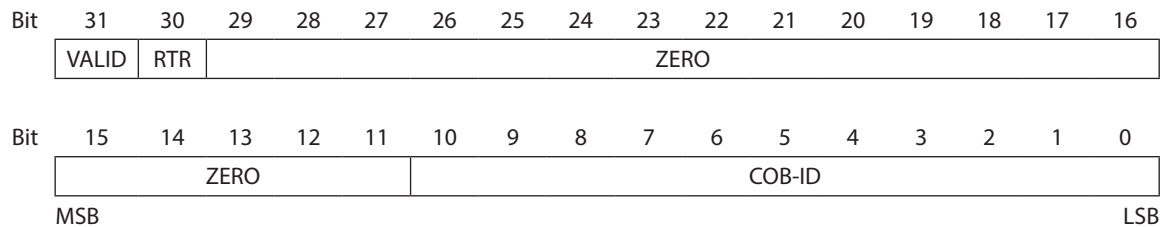

Bit	Notation	Meaning
0 to 10	COB-ID	11-bit COB-ID
11 to 29	ZERO	Set to "0"
30	RTR	0: RTR allowed on this PDO 1: no RTR allowed on this PDO
31	VALID	0: PDO exists / is valid 1: PDO does not exist / is not valid

Sub-index 02h defines the transmission character of the TPDO. An attempt to change the value of the transmission type to any not supported value is responded with the SDO abort transfer service (abort code: 0609 0030h).

Data Description of Sub-index 02h

Value	Description
00h	synchronous (acyclic)
01h	synchronous (cyclic every SYNC)
02h	synchronous (cyclic every 2nd SYNC)
03h	synchronous (cyclic every 3rd SYNC)
:	:
:	:
F0h	synchronous (cyclic every 240th SYNC)
F1h to FBh	Reserved
FCh	RTR-only (synchronous)
FDh	RTR-only (event-driven)
FEh	event-driven
FFh	event-driven

Sub-index 03h contains the inhibit time. The time is the minimum interval for PDO transmission if the transmission type is set to FEh and FFh. The value is defined as multiple of 100 microseconds.

The value of 0 is disable the inhibit time.

The value shall not be changed while the PDO exists (bit 31 of sub-index 01h is set to 0b).

Sub-index 04h is reserved. It does shall not be implemented; in this case read or write access leads to the SDO abort transfer service (abort code: 0609 0011h).

Sub-index 05h contains the event-timer. The time is the maximum interval for PDO transmission if the transmission type is set to FEh and FFh.

The value is defined as multiple of 1 millisecond. The value of 0 is disable the event-timer.

● **1802h: 3rd TPDO communication parameter**

This object contains the communication parameters for the PDOs the driver is able to transmit (TPDO3).

Index	Sub-index	Name	Data type	Access	PDO	Value (Default)	Unit	Save
1802h	3rd TPDO communication parameter							
	00h	Highest sub-index supported	UINT8	ro	No	5	-	No
	01h	COB-ID used by TPDO	UINT32	rw	No	0000 0000h to FFFF FFFFh (4000 0380h + Node-ID)	-	Yes
	02h	Transmission type	UINT8	rw	No	0 to 255 (1)	-	Yes
	03h	Inhibit time	UINT16	rw	No	0 to 65,535 (50)	100 µs	Yes
	04h	Reserved	-	-	-	-	-	-
	05h	Event timer	UINT16	rw	No	0 to 65,535 (0)	ms	Yes

Data Description of Sub-index 01h

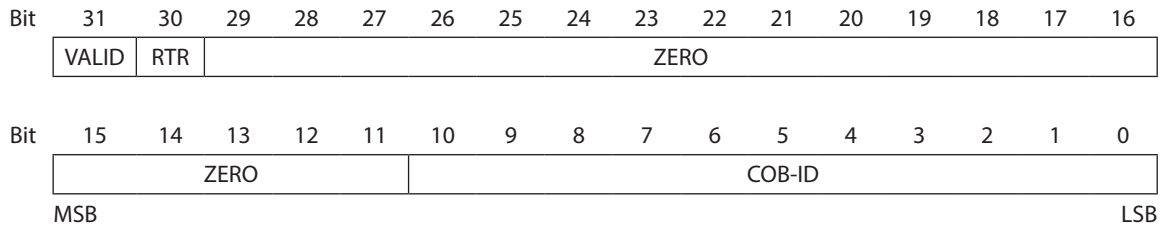

Bit	Notation	Meaning
0 to 10	COB-ID	11-bit COB-ID
11 to 29	ZERO	Set to "0"
30	RTR	0: RTR allowed on this PDO 1: no RTR allowed on this PDO
31	VALID	0: PDO exists / is valid 1: PDO does not exist / is not valid

Sub-index 02h defines the transmission character of the TPDO. An attempt to change the value of the transmission type to any not supported value is responded with the SDO abort transfer service (abort code: 0609 0030h).

Data Description of Sub-index 02h

Value	Description
00h	synchronous (acyclic)
01h	synchronous (cyclic every SYNC)
02h	synchronous (cyclic every 2nd SYNC)
03h	synchronous (cyclic every 3rd SYNC)
:	:
:	:
F0h	synchronous (cyclic every 240th SYNC)
F1h to FBh	Reserved
FCh	RTR-only (synchronous)
FDh	RTR-only (event-driven)
FEh	event-driven
FFh	event-driven

Sub-index 03h contains the inhibit time. The time is the minimum interval for PDO transmission if the transmission type is set to FEh and FFh. The value is defined as multiple of 100 microseconds.

The value of 0 is disable the inhibit time.

The value shall not be changed while the PDO exists (bit 31 of sub-index 01h is set to 0b).

Sub-index 04h is reserved. It does shall not be implemented; in this case read or write access leads to the SDO abort transfer service (abort code: 0609 0011h).

Sub-index 05h contains the event-timer. The time is the maximum interval for PDO transmission if the transmission type is set to FEh and FFh.

The value is defined as multiple of 1 millisecond. The value of 0 is disable the event-timer.

- **1803h: 4th TPDO communication parameter**

This object contains the communication parameters for the PDOs the driver is able to transmit (TPDO4).

Index	Sub-index	Name	Data type	Access	PDO	Value (Default)	Unit	Save
1803h	4th TPDO communication parameter							
	00h	Highest sub-index supported	UINT8	ro	No	5	–	No
	01h	COB-ID used by TPDO	UINT32	rw	No	0000 0000h to FFFF FFFFh (4000 0480h + Node-ID)	–	Yes
	02h	Transmission type	UINT8	rw	No	0 to 255 (1)	–	Yes
	03h	Inhibit time	UINT16	rw	No	0 to 65,535 (50)	100 µs	Yes
	04h	Reserved	–	–	–	–	–	–
	05h	Event timer	UINT16	rw	No	0 to 65,535 (0)	ms	Yes

Data Description of Sub-index 01h

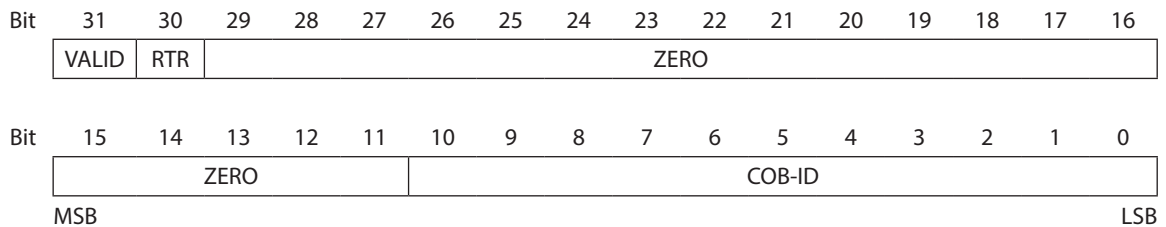

Bit	Notation	Meaning
0 to 10	COB-ID	11-bit COB-ID
11 to 29	ZERO	Set to "0"
30	RTR	0: RTR allowed on this PDO 1: no RTR allowed on this PDO
31	VALID	0: PDO exists / is valid 1: PDO does not exist / is not valid

Sub-index 02h defines the transmission character of the TPDO. An attempt to change the value of the transmission type to any not supported value is responded with the SDO abort transfer service (abort code: 0609 0030h).

Data Description of Sub-index 02h

Value	Description
00h	synchronous (acyclic)
01h	synchronous (cyclic every SYNC)
02h	synchronous (cyclic every 2nd SYNC)
03h	synchronous (cyclic every 3rd SYNC)
:	:
:	:
F0h	synchronous (cyclic every 240th SYNC)
F1h to FBh	Reserved
FCh	RTR-only (synchronous)
FDh	RTR-only (event-driven)
FEh	event-driven
FFh	event-driven

Sub-index 03h contains the inhibit time. The time is the minimum interval for PDO transmission if the transmission type is set to FEh and FFh. The value is defined as multiple of 100 microseconds.

The value of 0 is disable the inhibit time.

The value shall not be changed while the PDO exists (bit 31 of sub-index 01h is set to 0b).

Sub-index 04h is reserved. It does shall not be implemented; in this case read or write access leads to the SDO abort transfer service (abort code: 0609 0011h).

Sub-index 05h contains the event-timer. The time is the maximum interval for PDO transmission if the transmission type is set to FEh and FFh.

The value is defined as multiple of 1 millisecond. The value of 0 is disable the event-timer.

- **1A00h: 1st TPDO mapping parameter**

This object contains the mapping for the PDOs the driver is able to transmit. (TPDO1)

Index	Sub-index	Name	Data type	Access	PDO	Value (Default)	Unit	Save
1A00h	1st TPDO mapping parameter							
	00h	Number of mapped application objects in TPDO	UINT8	rw	No	1	–	Yes
	01h	1st application object	UINT32	rw	No	0000 0000h to FFFF FFFFh (6041 0010h)	–	Yes
	02h	2nd application object	UINT32	rw	No	0000 0000h to FFFF FFFFh (0000 0000h)	–	Yes
	03h	3rd application object	UINT32	rw	No	0000 0000h to FFFF FFFFh (0000 0000h)	–	Yes
	04h	4th application object	UINT32	rw	No	0000 0000h to FFFF FFFFh (0000 0000h)	–	Yes

Data Description of Sub-index 01h to 04h

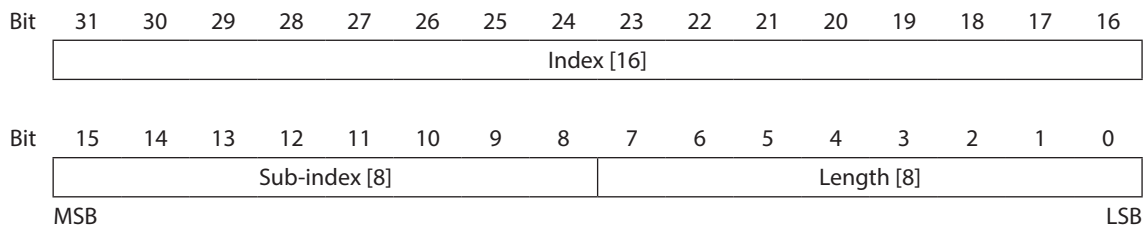

Bit	Notation	Meaning
0 to 7	Length	This contains the length of the object to be mapped in units of bits.
8 to 15	Sub-index	This contains the sub-index of the object to be mapped.
16 to 31	Index	This contains the index of the object to be mapped.

- **1A01h: 2nd TPDO mapping parameter**

This object contains the mapping for the PDOs the driver is able to transmit. (TPDO2)

Index	Sub-index	Name	Data type	Access	PDO	Value (Default)	Unit	Save
1A01h	2nd TPDO mapping parameter							
	00h	Number of mapped application objects in TPDO	UINT8	rw	No	2	–	Yes
	01h	1st application object	UINT32	rw	No	0000 0000h to FFFF FFFFh (6041 0010h)	–	Yes
	02h	2nd application object	UINT32	rw	No	0000 0000h to FFFF FFFFh (6061 0008h)	–	Yes
	03h	3rd application object	UINT32	rw	No	0000 0000h to FFFF FFFFh (0000 0000h)	–	Yes
	04h	4th application object	UINT32	rw	No	0000 0000h to FFFF FFFFh (0000 0000h)	–	Yes

Data Description of Sub-index 01h to 04h

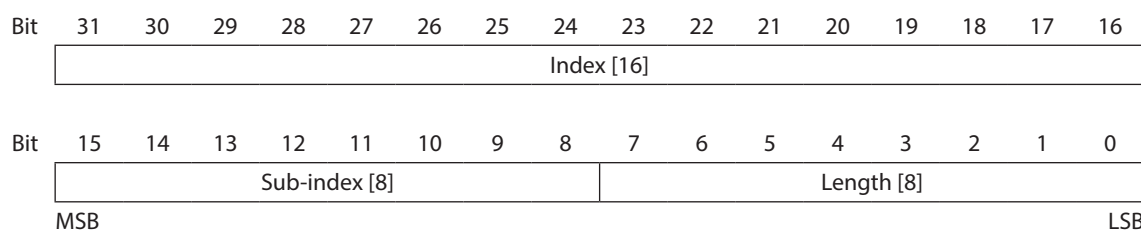

Bit	Notation	Meaning
0 to 7	Length	This contains the length of the object to be mapped in units of bits.
8 to 15	Sub-index	This contains the sub-index of the object to be mapped.
16 to 31	Index	This contains the index of the object to be mapped.

- **1A02h: 3rd TPDO mapping parameter**

This object contains the mapping for the PDOs the driver is able to transmit. (TPDO3)

Index	Sub-index	Name	Data type	Access	PDO	Value (Default)	Unit	Save
1A02h	3rd TPDO mapping parameter							
	00h	Number of mapped application objects in TPDO	UINT8	rw	No	2	–	Yes
	01h	1st application object	UINT32	rw	No	0000 0000h to FFFF FFFFh (6041 0010h)	–	Yes
	02h	2nd application object	UINT32	rw	No	0000 0000h to FFFF FFFFh (6064 0020h)	–	Yes
	03h	3rd application object	UINT32	rw	No	0000 0000h to FFFF FFFFh (0000 0000h)	–	Yes
	04h	4th application object	UINT32	rw	No	0000 0000h to FFFF FFFFh (0000 0000h)	–	Yes

Data Description of Sub-index 01h to 04h

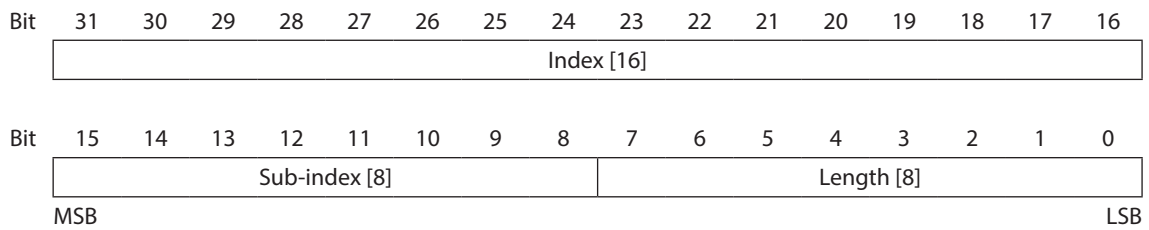

Bit	Notation	Meaning
0 to 7	Length	This contains the length of the object to be mapped in units of bits.
8 to 15	Sub-index	This contains the sub-index of the object to be mapped.
16 to 31	Index	This contains the index of the object to be mapped.

- **1A03h: 4th TPDO mapping parameter**

This object contains the mapping for the PDOs the driver is able to transmit. (TPDO4)

Index	Sub-index	Name	Data type	Access	PDO	Value (Default)	Unit	Save
1A03h	4th TPDO mapping parameter							
	00h	Number of mapped application objects in TPDO	UINT8	rw	No	2	–	Yes
	01h	1st application object	UINT32	rw	No	0000 0000h to FFFF FFFFh (6041 0010h)	–	Yes
	02h	2nd application object	UINT32	rw	No	0000 0000h to FFFF FFFFh (606C 0020h)	–	Yes
	03h	3rd application object	UINT32	rw	No	0000 0000h to FFFF FFFFh (0000 0000h)	–	Yes
	04h	4th application object	UINT32	rw	No	0000 0000h to FFFF FFFFh (0000 0000h)	–	Yes

Data Description of Sub-index 01h to 04h

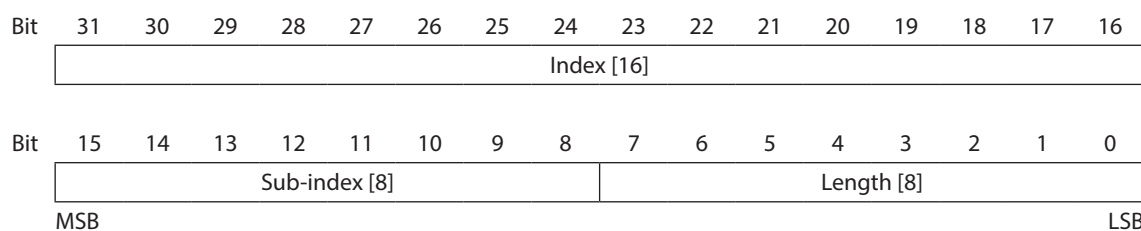

Bit	Notation	Meaning
0 to 7	Length	This contains the length of the object to be mapped in units of bits.
8 to 15	Sub-index	This contains the sub-index of the object to be mapped.
16 to 31	Index	This contains the index of the object to be mapped.

8.2 Manufacturer Specific Objects

Refer to the following for details on the Manufacturer Specific Objects.

- OPERATING MANUAL **BLV** Series **R** Type Function Edition

- **402Ch: Direct data operation operation data number**

This object is the operation data number to be used in direct data operation.

Index	Sub-index	Name	Data type	Access	PDO	Value (Default)	Unit	Save
402Ch	00h	Direct data operation operation data number	INT16	rww	Yes	0 to 255 (0)	-	No

- **402Dh: Direct data operation operation type**

This object is the operation type for direct data operation.

Index	Sub-index	Name	Data type	Access	PDO	Value (Default)	Unit	Save
402Dh	00h	Direct data operation operation type	UINT8	rww	Yes	0 to 255 (0)	-	No

- **402Eh: Direct data operation position**

This object is the target position for direct data operation.

Index	Sub-index	Name	Data type	Access	PDO	Value (Default)	Unit	Save
402Eh	00h	Direct data operation position	INT32	rww	Yes	-2,147,483,648 to 2,147,483,647 (0)	Pos. unit	No

- **402Fh: Direct data operation operating velocity**

This object is the operating velocity for direct data operation.

Index	Sub-index	Name	Data type	Access	PDO	Value (Default)	Unit	Save
402Fh	00h	Direct data operation operating velocity	INT32	rww	Yes	-4,000,000 to 4,000,000 (0)	Vel. unit	No

- **4030h: Direct data operation acceleration rate**

This object is the acceleration rate (acceleration time) for direct data operation.

Index	Sub-index	Name	Data type	Access	PDO	Value (Default)	Unit	Save
4030h	00h	Direct data operation acceleration rate	INT32	rww	Yes	1 to 1,000,000,000 (1,000)	Acc. unit (MS)	No

- **4031h: Direct data operation deceleration rate**

This object is the deceleration rate (deceleration time) for direct data operation.

Index	Sub-index	Name	Data type	Access	PDO	Value (Default)	Unit	Save
4031h	00h	Direct data operation deceleration rate	INT32	rww	Yes	1 to 1,000,000,000 (1,000)	Acc. unit (MS)	No

- **4032h: Direct data operation torque limiting value**

This object is the torque limiting value for direct data operation.

Index	Sub-index	Name	Data type	Access	PDO	Value (Default)	Unit	Save
4032h	00h	Direct data operation torque limiting value	INT16	rww	Yes	0 to 10,000 (10,000)	0.1%	No

- **4033h: Direct data operation trigger**

This object is the trigger for direct data operation.

Index	Sub-index	Name	Data type	Access	PDO	Value (Default)	Unit	Save
4033h	00h	Direct data operation trigger	INT32	rww	Yes	-7 to 2,147,418,131 (0)	-	No

- **4034h: Direct data operation forwarding destination**

This object is the stored area when the next direct data is transferred during direct data operation.

Index	Sub-index	Name	Data type	Access	PDO	Value (Default)	Unit	Save
4034h	00h	Direct data operation forwarding destination	UINT8	rww	Yes	0 to 1 (0)	-	No

- **403Ah: Driver input command (2nd)**

This object is the same input command as "Driver input command".

Index	Sub-index	Name	Data type	Access	PDO	Value (Default)	Unit	Save
403Ah	00h	Driver input command (2nd)	UINT32	rww	Yes	0000 0000h to FFFF FFFFh (0000 0000h)	-	No

- **403Ch: Driver input command (automatic OFF)**

This object is the same input command as "Driver input command". If the input signal is turned ON with this command, it is automatically turned OFF after 250 μ s.

Index	Sub-index	Name	Data type	Access	PDO	Value (Default)	Unit	Save
403Ch	00h	Driver input command (automatic OFF)	UINT32	rww	Yes	0000 0000h to FFFF FFFFh (0000 0000h)	-	No

- **403Dh: NET selection data number**

This object is the operation data number.

Index	Sub-index	Name	Data type	Access	PDO	Value (Default)	Unit	Save
403Dh	00h	NET selection data number	UINT32	rww	Yes	0 to 255 (0)	-	No

- **403Eh: Driver input command**

This object is the input command to the driver.

Index	Sub-index	Name	Data type	Access	PDO	Value (Default)	Unit	Save
403Eh	00h	Driver input command	UINT32	rww	Yes	0000 0000h to FFFF FFFFh (0000 0000h)	-	No

- **403Fh: Driver output status**

This object is the output status of the driver.

Index	Sub-index	Name	Data type	Access	PDO	Value (Default)	Unit	Save
403Fh	00h	Driver output status	UINT32	ro	Yes	-	-	No

- **404Bh: Target position (User-defined position unit)**

This object is the present target position. The value is given in user-defined position units.

Index	Sub-index	Name	Data type	Access	PDO	Value (Default)	Unit	Save
404Bh	00h	Target position (User-defined position unit)	INT32	ro	Yes	–	Pos. unit	No

- **404Ch: Demand position (User-defined position unit)**

This object is the present demand position. The value is given in user-defined position units.

Index	Sub-index	Name	Data type	Access	PDO	Value (Default)	Unit	Save
404Ch	00h	Demand position (User-defined position unit)	INT32	ro	Yes	–	Pos. unit	No

- **404Dh: Actual position (User-defined position unit)**

This object is the present actual position. The value is given in user-defined position units.

Index	Sub-index	Name	Data type	Access	PDO	Value (Default)	Unit	Save
404Dh	00h	Actual position (User-defined position unit)	INT32	ro	Yes	–	Pos. unit	No

- **404Eh: Target velocity (User-defined velocity unit)**

This object is the present target velocity. The value is given in user-defined velocity units.

Index	Sub-index	Name	Data type	Access	PDO	Value (Default)	Unit	Save
404Eh	00h	Target velocity (User-defined velocity unit)	INT32	ro	Yes	–	Vel. unit	No

- **404Fh: Demand velocity (User-defined velocity unit)**

This object is the present demand velocity. The value is given in user-defined velocity units.

Index	Sub-index	Name	Data type	Access	PDO	Value (Default)	Unit	Save
404Fh	00h	Demand velocity (User-defined velocity unit)	INT32	ro	Yes	–	Vel. unit	No

- **4050h: Actual velocity (User-defined velocity unit)**

This object is the present demand velocity. The value is given in user-defined velocity units.

Index	Sub-index	Name	Data type	Access	PDO	Value (Default)	Unit	Save
4050h	00h	Actual velocity (User-defined velocity unit)	INT32	ro	Yes	–	Vel. unit	No

- **4056h: Present communication error**

This object is the communication error code received last time.

Index	Sub-index	Name	Data type	Access	PDO	Value (Default)	Unit	Save
4056h	00h	Present communication error	UINT8	ro	Yes	–	–	No

- **406Bh: Torque monitor**

This object is the output torque presently generated as a percentage of the rated torque.

Index	Sub-index	Name	Data type	Access	PDO	Value (Default)	Unit	Save
406Bh	00h	Torque monitor	INT16	ro	Yes	–	0.1%	No

- **406Ch: Load factor monitor**

This object is the output torque presently generated as a percentage of the maximum torque in the continuous duty region.

Index	Sub-index	Name	Data type	Access	PDO	Value (Default)	Unit	Save
406Ch	00h	Load factor monitor	INT32	ro	Yes	–	0.1%	No

- **406Dh: Cumulative load monitor**

This object is the integrated value of the load during operation. (Internal unit)
The load is accumulated regardless of the rotation direction of the motor.

Index	Sub-index	Name	Data type	Access	PDO	Value (Default)	Unit	Save
406Dh	00h	Cumulative load monitor	UINT32	ro	Yes	–	–	No

- **4070h: Next data number**

This object is the operation data number specified in "Next data number" of the operation data in operation. The value is latched also after the operation is complete. When "Link" is "No Link" or "Next data number" is "Stop," –1 is displayed.

Index	Sub-index	Name	Data type	Access	PDO	Value (Default)	Unit	Save
4070h	00h	Next data number	INT16	ro	Yes	–	–	No

- **4071h: Loop origin data number**

This object is the operation data number that is the starting point of the loop in loop operation (extended loop operation). When loop is not executed or stopped, –1 is displayed.

Index	Sub-index	Name	Data type	Access	PDO	Value (Default)	Unit	Save
4071h	00h	Loop origin data number	INT16	ro	Yes	–	–	No

- **4072h: Loop count**

This object is the current number of times of loop in loop operation (extended loop operation). When operation other than loop is executed or loop is stopped, 0 is displayed.

Index	Sub-index	Name	Data type	Access	PDO	Value (Default)	Unit	Save
4072h	00h	Loop count	UINT32	ro	Yes	–	–	No

- **4073h: Position deviation**

This object is the deviation between the demand position and actual position.
The value is given in user-defined velocity units.

Index	Sub-index	Name	Data type	Access	PDO	Value (Default)	Unit	Save
4073h	00h	Position deviation	INT32	ro	Yes	–	Pos. unit	No

- **4075h: Speed deviation**

This object is the deviation between the demand position having input to the position controller and the actual position. The value is given in user-defined velocity units.

Index	Sub-index	Name	Data type	Access	PDO	Value (Default)	Unit	Save
4075h	00h	Speed deviation	INT32	ro	Yes	–	Vel. unit	No

- **407Ah: Tripmeter 1**

This object is the travel distance of the motor in revolutions. (1=0.1 krev)
This can be cleared on the customer side.

Index	Sub-index	Name	Data type	Access	PDO	Value (Default)	Unit	Save
407Ah	00h	Tripmeter 1	INT32	ro	Yes	–	0.1 krev	No

- **407Bh: Present information**

This object is the information status presently being generated.

Index	Sub-index	Name	Data type	Access	PDO	Value (Default)	Unit	Save
407Bh	00h	Information status 1	UINT32	ro	Yes	–	–	No

- **407Ch: Driver temperature**

This object is the present driver temperature. (1=0.1 °C)

Index	Sub-index	Name	Data type	Access	PDO	Value (Default)	Unit	Save
407Ch	00h	Driver temperature	INT16	ro	Yes	–	0.1 °C	No

- **407Dh: Motor temperature**

This object is the present motor temperature. (1=0.1 °C)

Index	Sub-index	Name	Data type	Access	PDO	Value (Default)	Unit	Save
407Dh	00h	Motor temperature	INT16	ro	Yes	–	0.1 °C	No

- **407Eh: Odometer**

This object is the cumulative travel distance of the motor in revolutions. (1=0.1 krev)

This cannot be cleared on the customer side.

Index	Sub-index	Name	Data type	Access	PDO	Value (Default)	Unit	Save
407Eh	00h	Odometer	UINT32	ro	Yes	–	0.1 krev	No

- **407Fh: Tripmeter 0**

This object is the travel distance of the motor in revolutions. (1=0.1 krev)

This can be cleared on the customer side.

Index	Sub-index	Name	Data type	Access	PDO	Value (Default)	Unit	Save
407Fh	00h	Tripmeter 0	UINT32	ro	Yes	–	0.1 krev	No

- **409Bh: Main power supply current**

This object is the present current value of the main power supply. (1=0.001 A)

Index	Sub-index	Name	Data type	Access	PDO	Value (Default)	Unit	Save
409Bh	00h	Main power supply current	INT32	ro	Yes	–	0.001 A	No

- **409Ch: Power consumption**

This object is the present power consumption. (1=0.1 W)

Index	Sub-index	Name	Data type	Access	PDO	Value (Default)	Unit	Save
409Ch	00h	Power consumption	UINT32	ro	Yes	–	0.1 W	No

- **409Dh: Energy consumption**

This object is the present energy consumption. (1=0.001 Wh)

Index	Sub-index	Name	Data type	Access	PDO	Value (Default)	Unit	Save
409Dh	00h	Energy consumption	UINT32	ro	Yes	–	0.001 Wh	No

- **409Eh: User energy consumption**

This object is the total energy consumption.
This can be cleared on the customer side.

Index	Sub-index	Name	Data type	Access	PDO	Value (Default)	Unit	Save
409Eh	00h	User energy consumption	UINT32	ro	Yes	–	Wh	No

- **409Fh: Total energy consumption**

This object indicates the total energy consumption.
This cannot be cleared on the customer side.

Index	Sub-index	Name	Data type	Access	PDO	Value (Default)	Unit	Save
409Fh	00h	Total energy consumption	UINT32	ro	Yes	–	Wh	No

- **40A1h: Total uptime**

This object is the total time that has elapsed since the main power supply was turned on. (min)

Index	Sub-index	Name	Data type	Access	PDO	Value (Default)	Unit	Save
40A1h	00h	Total uptime	UINT32	ro	Yes	–	min	No

- **40A2h: Number of boots**

This object is the total number of times that the driver was started.

Index	Sub-index	Name	Data type	Access	PDO	Value (Default)	Unit	Save
40A2h	00h	Number of boots	UINT32	ro	Yes	–	–	No

- **40A3h: Inverter voltage**

This object is the inverter voltage of the driver. (1=0.1 V)

Index	Sub-index	Name	Data type	Access	PDO	Value (Default)	Unit	Save
40A3h	00h	Inverter voltage	INT16	ro	Yes	–	0.1 V	No

- **40A4h: Main power supply voltage**

This object is the main power supply voltage. (1=0.1 V)

Index	Sub-index	Name	Data type	Access	PDO	Value (Default)	Unit	Save
40A4h	00h	Main power supply voltage	INT16	ro	Yes	–	0.1 V	No

- **40A9h: Continuous uptime**

This object is the time at which the main power supply is supplied continuously. (ms)

Index	Sub-index	Name	Data type	Access	PDO	Value (Default)	Unit	Save
40A9h	00h	Continuous uptime	UINT32	ro	Yes	–	ms	No

- **40AAh: RS-485 communication reception byte counter**

This object is the number of bytes received.

Index	Sub-index	Name	Data type	Access	PDO	Value (Default)	Unit	Save
40AAh	00h	RS-485 communication reception byte counter	UINT32	ro	Yes	–	–	No

- **40ABh: RS-485 communication transmission byte counter**

This object is the number of bytes transmitted.

Index	Sub-index	Name	Data type	Access	PDO	Value (Default)	Unit	Save
40ABh	00h	RS-485 communication transmission byte counter	UINT32	ro	Yes	–	–	No

- **40C0h: Alarm reset**

This object resets the alarm being generated presently. Some alarms cannot be reset.

Index	Sub-index	Name	Data type	Access	PDO	Value (Default)	Unit	Save
40C0h	00h	Alarm reset	UINT8	rww	Yes	0 to 2 (0)	–	No

- **40C2h: Clear alarm history**

This object clears the alarm history.

Index	Sub-index	Name	Data type	Access	PDO	Value (Default)	Unit	Save
40C2h	00h	Clear alarm history	UINT8	rww	Yes	0 to 2 (0)	–	No

- **40C5h: P-PRESET execution**

This object is presets the demand position.

Index	Sub-index	Name	Data type	Access	PDO	Value (Default)	Unit	Save
40C5h	00h	P-PRESET execution	UINT8	rww	Yes	0 to 2 (0)	–	No

- **40C6h: Configuration**

This object executes recalculation and setup of the parameter.

Index	Sub-index	Name	Data type	Access	PDO	Value (Default)	Unit	Save
40C6h	00h	Configuration	UINT8	rww	Yes	0 to 2 (0)	–	No

- **40CDh: Clear latch information**

This object clears latch information.

Index	Sub-index	Name	Data type	Access	PDO	Value (Default)	Unit	Save
40CDh	00h	Clear latch information	UINT8	rww	Yes	0 to 2 (0)	–	No

- **40CEh: Clear sequence history**

This object clears sequence history.

Index	Sub-index	Name	Data type	Access	PDO	Value (Default)	Unit	Save
40CEh	00h	Clear sequence history	UINT8	rww	Yes	0 to 2 (0)	–	No

- **40D0h: Clear ETO**

This object releases the ETO status.

Index	Sub-index	Name	Data type	Access	PDO	Value (Default)	Unit	Save
40D0h	00h	Clear ETO	UINT8	rww	Yes	0 to 2 (0)	–	No

- **40D1h: ZSG-PRESET**

This object sets the position of the ZSG-N output again.

Index	Sub-index	Name	Data type	Access	PDO	Value (Default)	Unit	Save
40D1h	00h	ZSG-PRESET	UINT8	rww	Yes	0 to 2 (0)	–	No

- **40D2h: Clear ZSG-PRESET**

This object clears the position data of the ZSG-N output that was set again with the "ZSG-PRESET command."

Index	Sub-index	Name	Data type	Access	PDO	Value (Default)	Unit	Save
40D2h	00h	Clear ZSG-PRESET	UINT8	rww	Yes	0 to 2 (0)	–	No

- **40D3h: Clear information**

This object clears the information.

Index	Sub-index	Name	Data type	Access	PDO	Value (Default)	Unit	Save
40D3h	00h	Clear information	UINT8	rww	Yes	0 to 2 (0)	–	No

- **40D6h: Clear user energy consumption**

This object clears the user energy consumption.

Index	Sub-index	Name	Data type	Access	PDO	Value (Default)	Unit	Save
40D6h	00h	Clear user energy consumption	UINT8	rww	Yes	0 to 2 (0)	–	No

- **40D7h: Clear tripmeter 0**

This object clear tripmeter 0

Index	Sub-index	Name	Data type	Access	PDO	Value (Default)	Unit	Save
40D7h	00h	Clear tripmeter 0	UINT8	rww	Yes	0 to 2 (0)	–	No

- **40D8h: Clear tripmeter 1**

This object clear tripmeter 1

Index	Sub-index	Name	Data type	Access	PDO	Value (Default)	Unit	Save
40D8h	00h	Clear tripmeter 1	UINT8	rww	Yes	0 to 2 (0)	–	No

- **4148h: Permission of absolute positioning without setting absolute coordinates**

This object permits absolute positioning operation in a state where the position coordinate has not been set.

Index	Sub-index	Name	Data type	Access	PDO	Value (Default)	Unit	Save
4148h	00h	Permission of absolute positioning without setting absolute coordinates	UINT8	rww	Yes	0 to 1 (0)	–	No

- **415Fh: JOG/HOME Torque limit value**

This object is the torque limiting value.

Index	Sub-index	Name	Data type	Access	PDO	Value (Default)	Unit	Save
415Fh	00h	JOG/HOME Torque limit value	UINT16	rww	Yes	0 to 10000 (10000)	0.1%	Yes

- **4160h: (HOME) Homing mode**

This object is the homing method.

Index	Sub-index	Name	Data type	Access	PDO	Value (Default)	Unit	Save
4160h	00h	(HOME) Homing mode	UINT8	rww	Yes	0 to 3 (1)	–	Yes

- **4163h: (HOME) Starting velocity**

This object is the starting velocity. The value is given in user-defined velocity units.

Index	Sub-index	Name	Data type	Access	PDO	Value (Default)	Unit	Save
4163h	00h	(HOME) Starting velocity	UINT32	rww	Yes	1 to 4000000 (30)	Vel. unit	Yes

- **4169h: (HOME) Backward steps in 2 sensor homeseeking**

This object is the amount of backward steps after homing operation in 2-sensor mode.

Index	Sub-index	Name	Data type	Access	PDO	Value (Default)	Unit	Save
4169h	00h	(HOME) Backward steps in 2 sensor homeseeking	UINT32	rww	Yes	0 to 8388607 (18000)	Pos. unit	Yes

- **4186h: Stopping timeout at alarm generation**

This object is the time-out period from when the alarm of "Non-excitation after deceleration" is generated until the excitation is turned off.

Index	Sub-index	Name	Data type	Access	PDO	Value (Default)	Unit	Save
4186h	00h	Stopping timeout at alarm generation	UINT16	rww	Yes	0 to 10000 (3000)	ms	Yes

- **41CAh: WRAP setting**

This object is the WRAP setting.

Index	Sub-index	Name	Data type	Access	PDO	Value (Default)	Unit	Save
41CAh	00h	WRAP setting	UINT8	rww	Yes	1 to 2 (1)	–	Yes

- **4735h: Custom stopping rate**

This object is the deceleration rate when select the "Deceleration rate stop (according to the Custom stopping rate parameter)" in parameter of "STOP input action" or "QSTOP input action".

Index	Sub-index	Name	Data type	Access	PDO	Value (Default)	Unit	Save
4735h	00h	Custom stopping rate	UINT32	rww	Yes	1 to 1000000000 (1000)	Acc. unit	Yes

- **4736h: Custom stopping time**

This object is the deceleration time when select the "Deceleration time stop (according to the Custom stopping time parameter)" in parameter of "STOP input action" or "QSTOP input action".

Index	Sub-index	Name	Data type	Access	PDO	Value (Default)	Unit	Save
4736h	00h	Custom stopping time	UINT32	rww	Yes	1 to 1000000000 (1000)	ms	Yes

8.3 Device Profile Objects

- **603Fh: Error code**

This object provides the error code of the last error that occurred. (The latest alarm history of the driver + FF00h.)

Index	Sub-index	Name	Data type	Access	PDO	Value (Default)	Unit	Save
603Fh	00h	Error code	UINT16	ro	Yes	-	-	No

- **6040h: Controlword**

This object controls the driver and operation mode.

Index	Sub-index	Name	Data type	Access	PDO	Value (Default)	Unit	Save
6040h	00h	Controlword	UINT16	rww	Yes	0000h to FFFFh (0004h)	-	No

Data Description

Bit	15	14	13	12	11	10	9	8	7	6	5	4	3	2	1	0
	MS [5]					RSV	OMS	HALT	FR	OMS [3]			EO	QS	EV	SO
	MSB															LSB

Bit	Notation	Meaning	Description
0	SO	Switch on	Status Machine control commands
1	EV	Enable voltage	
2	QS	Quick stop	
3	EO	Enable operation	
4 to 6	OMS	Operation mode specific	For details, refer to each operation mode.
7	FR	Fault reset	0 -> 1: Alarm reset
8	HALT	Halt	For details, refer to each operation mode.
9	OMS	Operation mode specific	
10	RSV	Reserved	Reserved
11 to 15	MS	Manufacturer specific	Manufacturer-specific bit For details, refer to each operation mode.

Operation mode

- Profile Velocity Mode (pv)
- Profile Position Mode (pp)
- Homing Mode (hm)

● 6041h: Statusword

This object contains the bits that provide the current state of the driver and the operating state of the operation mode.

Index	Sub-index	Name	Data type	Access	PDO	Value (Default)	Unit	Save
6041h	00h	Statusword	UINT16	ro	Yes	–	–	No

Data Description

Bit	15	14	13	12	11	10	9	8	7	6	5	4	3	2	1	0
	MS [2]		OMS [2]		ILA	TR	RM	RDY	W	SOD	QS	VE	F	OE	SO	RTSO
	MSB															LSB

Bit	Notation	Meaning	Description
0	RTSO	Ready to switch on	Current state of the driver.
1	SO	Switch on	
2	OE	Operation enabled	
3	F	Fault	
4	VE	Voltage enabled	
5	QS	Quick stop	
6	SOD	Switch on disabled	
7	W	Warning	0: No alarm occurred 1: Alarm occurred
8	MS	Manufacturer specific	Manufacturer-specific bit For details, refer to each operation mode.
9	RM	Remote	0: Controlword is not processed. * 1: Controlword is processed.
10	TR	Target reached	Refer to following table.
11	ILA	Internal limit active	The internal limit is activated in the following cases: - The software limit was activated. - The FW-LS or RV-LS signal was activated. - The FW-BLK or RV-BLK signal was activated. - The STOP or QSTOP signal was activated. - The CLR signal was activated.
12 to 13	OMS	Operation mode specific	For details, refer to each operation mode.
14 to 15	MS	Manufacturer specific	Manufacturer-specific bit For details, refer to each operation mode.

* The Remote (bit 9) is "0" when any of the following conditions.

- The S-ON signal is active.
- Remote operation, data writing, or I/O test is executed with the support soft.

Operation mode

- Profile Velocity Mode (pv)
- Profile Position Mode (pp)
- Homing Mode (hm)

- **605Ah: Quick stop option code**

This object determines what operation will be performed if a Quick Stop is executed.

Index	Sub-index	Name	Data type	Access	PDO	Value (Default)	Unit	Save
605Ah	00h	Quick stop option code	INT16	rw	No	-3 to 6 (2)	-	No

Value	Description
-3	Decelerates with the Custom stopping time (4736h) and stay in Quick stop active state.
-2	Decelerates with the Custom stopping rate (4735h) and stay in Quick stop active state.
-1	Immediate stop and stay in Quick stop active state.
0	Immediate stop and transit into Switch on disabled state.
1	Decelerates with slow down ramp (deceleration ramp depending on operating mode) and transit into Switch on disabled state.
2	Decelerates with quick stop ramp (6085h) and transit into Switch on disabled state.
5	Decelerates with slow down ramp (deceleration ramp depending on operating mode) and stay in Quick stop active state.
6	Decelerates with quick stop ramp (6085h) and stay in Quick stop active state.

- **605Bh: Shutdown option code**

This object defines the operation that is performed if there is a transition from Operation enable state to Ready to switch on state.

Index	Sub-index	Name	Data type	Access	PDO	Value (Default)	Unit	Save
605Bh	00h	Shutdown option code	INT16	rw	No	0 to 1 (0)	-	Yes

Value	Description
0	Immediate stop and transit into Ready to switch on state.
1	Decelerates with slow down ramp (deceleration ramp depending on operating mode) and transit into Ready to switch on state.

- **605Ch: Disable operation option code**

This object defines the operation that is performed if there is a transition from Operation enable state to Switched on state.

Index	Sub-index	Name	Data type	Access	PDO	Value (Default)	Unit	Save
605Ch	00h	Disable operation option code	INT16	rw	No	0 to 1 (1)	-	Yes

Value	Description
0	Immediate stop and transit into Switched on state.
1	Decelerates with slow down ramp (deceleration ramp depending on operating mode) and transit into Switched on state.

- **605Dh: Halt option code**

This object defines the operation that is performed if bit 8 (Halt) in controlword is active.

Index	Sub-index	Name	Data type	Access	PDO	Value (Default)	Unit	Save
605Dh	00h	Halt option code	INT16	rw	No	0 to 1 (1)	-	Yes

Value	Description
0	Reserved
1	Decelerates with slow down ramp (deceleration ramp depending on operating mode except torque limit value).

- **605Eh: Fault reaction option code**

This object defines the operation that is performed when an alarm is detected in the driver.

Index	Sub-index	Name	Data type	Access	PDO	Value (Default)	Unit	Save
605Eh	00h	Fault reaction option code	INT16	rw	No	0 to 2 (2)	–	Yes

Value	Description
0	Immediate stop and motor will be non-excitation.
1	Decelerates with slow down ramp (deceleration ramp depending on operating mode).
2	Decelerates with quick stop ramp (6085h).

- **6060h: Modes of operation**

This object is used to select the operation mode. The driver provides the actual operation mode in the modes of operation display object (6061h).

Index	Sub-index	Name	Data type	Access	PDO	Value (Default)	Unit	Save
6060h	00h	Modes of operation	INT8	rww	Yes	0 to 6 (3)	–	Yes

Value	Description
0	There is no mode change or no mode assigned.
1	Profile Position Mode
3	Profile Velocity Mode
6	Homing Mode

- **6061h: Modes of operation display**

This object provides the actual operation mode.

Index	Sub-index	Name	Data type	Access	PDO	Value (Default)	Unit	Save
6061h	00h	Modes of operation display	INT8	ro	Yes	–	–	No

- **6062h: Position demand value**

This object provides the position demand value in user-defined position units.

Index	Sub-index	Name	Data type	Access	PDO	Value (Default)	Unit	Save
6062h	00h	Position demand value	INT32	ro	Yes	–	Pos. unit	No

- **6064h: Position actual value**

This object provides the position actual value in user-defined position units.

Index	Sub-index	Name	Data type	Access	PDO	Value (Default)	Unit	Save
6064h	00h	Position actual value	INT32	ro	Yes	–	Pos. unit	No

- **6065h: Following error window**

This object defines the detection range for the following error.

The value is given in user-defined position units.

Index	Sub-index	Name	Data type	Access	PDO	Value (Default)	Unit	Save
6065h	00h	Following error window	UINT32	rww	Yes	0 to 10,000,000 (108,000)	Pos. unit	Yes

- **6067h: Position window**

This object defines the configured symmetrical range of accepted positions relative to the target position.

If the actual position value is within the position window, this target position is regarded as having been reached (bit 10 (target reached) in statusword is set to 1). The value is given in user-defined position units.

Index	Sub-index	Name	Data type	Access	PDO	Value (Default)	Unit	Save
6067h	00h	Position window	UINT32	rww	Yes	0 to 65535 (18)	Pos. unit	Yes

- **606Bh: Velocity demand value**

This object provides the velocity demand value in user-defined velocity units.

Index	Sub-index	Name	Data type	Access	PDO	Value (Default)	Unit	Save
606Bh	00h	Velocity demand value	INT32	ro	Yes	–	Vel. unit	No

- **606Ch: Velocity actual value**

This object provides the velocity actual value in user-defined velocity units.

Index	Sub-index	Name	Data type	Access	PDO	Value (Default)	Unit	Save
606Ch	00h	Velocity actual value	INT32	ro	Yes	–	Vel. unit	No

- **606Dh: Velocity window**

This object defines the configured symmetrical range of accepted velocities relative to the target velocity.

If the actual velocity value is within the velocity window, this target velocity is regarded as having been reached (bit 10 (target reached) in statusword is set to 1). The value is given in user-defined velocity units.

Index	Sub-index	Name	Data type	Access	PDO	Value (Default)	Unit	Save
606Dh	00h	Velocity window	UINT16	rww	Yes	1 to 65,535 (15)	Vel. unit	Yes

- **606Fh: Velocity threshold**

This object defines the configured symmetrical range of accepted velocities relative to the zero.

The value is given in user-defined velocity units.

Index	Sub-index	Name	Data type	Access	PDO	Value (Default)	Unit	Save
606Fh	00h	Velocity threshold	UINT16	rww	Yes	1 to 65,535 (15)	Vel. unit	Yes

- **6072h: Max torque**

This object defines the configured maximum permissible torque in the motor.

The value is given per thousand of rated torque.

Index	Sub-index	Name	Data type	Access	PDO	Value (Default)	Unit	Save
6072h	00h	Max torque	UINT16	rww	Yes	0 to 10,000 (10,000)	0.1%	Yes

- **6077h: Torque actual value**

This object provides the actual value of the torque. It is correspond to the instantaneous torque in the motor.

The value is given per thousand of rated torque.

Index	Sub-index	Name	Data type	Access	PDO	Value (Default)	Unit	Save
6077h	00h	Torque actual value	INT16	ro	Yes	–	0.1%	No

- **607Ah: Target position**

This object contains the target position for the Profile Position Mode or Profile Velocity Mode.

In Profile Position Mode, the value of this object is interpreted as either an absolute or relative value depending on the Abs/Rel Flag in controlword.

In Profile Velocity Mode, the value is always interpreted as an absolute value.

Index	Sub-index	Name	Data type	Access	PDO	Value (Default)	Unit	Save
607Ah	00h	Target position	INT32	rww	Yes	-2,147,483,648 to 2,147,483,647 (0)	Pos. unit	No

- **607Bh: Position range limit**

This object is used to define the start and end of the range of movement for modulo axis.

The start of the range is defined by Sub-index 01h (Min position range limit) and the end by Sub-index 02h (Max position range limit).

To do this, Object 41CAh (WRAP setting) must have the value 2 applied.

Index	Sub-index	Name	Data type	Access	PDO	Value (Default)	Unit	Save
607Bh	Position range limit							
	00h	Highest Sub-index Supported	UINT8	c	No	2	-	No
	01h	Min position range limit	INT32	rww	Yes	-2,147,483,648 to 0 (0)	Pos. unit	Yes
	02h	Max position range limit	INT32	rww	Yes	0 to 2,147,483,648 (0)	Pos. unit	Yes

- **607Ch: Home offset**

This object is the configured difference between the zero position for the application and the machine home position (found during homing). During homing, the machine home position is found and once the homing is completed, the zero position is offset from the home position by adding the home offset to the home position.

Index	Sub-index	Name	Data type	Access	PDO	Value (Default)	Unit	Save
607Ch	00h	Home offset	INT32	rww	Yes	-2,147,483,648 to 2,147,483,647 (0)	Pos. unit	Yes

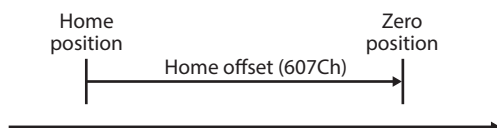

● 607Dh: Software position limit

This object defines the absolute positions of the limits to the target position (position demand value).

Every target position is checked against these limits. The limit positions are specified in user-defined position units, the same as for target positions, and are always relative to the machine home position.

The limit values are corrected internally for the home offset as given below. The target positions are compared with the corrected values.

- Corrected minimum position limit = Min position limit – Home offset (607Ch)
- Corrected maximum position limit = Max position limit – Home offset (607Ch)

The software position limits are enabled at the following times:

- When homing is completed

The software limits are disabled if they are set as follows:

- Min position limit \geq Max position limit
- Min position limit and Max position limit are set to "0"

Index	Sub-index	Name	Data type	Access	PDO	Value (Default)	Unit	Save
607Dh	Software position limit							
	00h	Highest Sub-index Supported	UINT8	c	No	2	-	No
	01h	Min position limit	INT32	rww	Yes	-2,147,483,648 to 2,147,483,647 (0)	Pos. unit	Yes
	02h	Max position limit	INT32	rww	Yes	-2,147,483,648 to 2,147,483,647 (0)	Pos. unit	Yes

Refer to the following for details on the software position limit.

- OPERATING MANUAL **BLV** Series **R** Type Function Edition

● 6081h: Profile velocity

This object is the final movement velocity at the end of acceleration for the Profile Position Mode or Profile Velocity Mode.

The value is given in user-defined velocity units.

Index	Sub-index	Name	Data type	Access	PDO	Value (Default)	Unit	Save
6081h	00h	Profile velocity	UINT32	rww	Yes	1 to 4,000,000 (1)	Pos. unit	Yes

● 6082h: End velocity

This object is the velocity at start and end of the ramp for the Profile Position Mode.

The value is given in user-defined velocity units.

Index	Sub-index	Name	Data type	Access	PDO	Value (Default)	Unit	Save
6082h	00h	End velocity	UINT32	rww	Yes	0 to 4,000,000 (1)	Vel. unit	Yes

● 6083h: Profile acceleration

This object is the acceleration rate for the Profile Position Mode or Profile Velocity Mode.

The value is given in user-defined acceleration units.

Index	Sub-index	Name	Data type	Access	PDO	Value (Default)	Unit	Save
6083h	00h	Profile acceleration	UINT32	rww	Yes	1 to 1,000,000,000 (1,000)	Acc. unit	Yes

- **6084h: Profile deceleration**

This object is the deceleration rate for the Profile Position Mode or Profile Velocity Mode.
The value is given in user-defined acceleration units.

Index	Sub-index	Name	Data type	Access	PDO	Value (Default)	Unit	Save
6084h	00h	Profile deceleration	UINT32	rww	Yes	1 to 1,000,000,000 (1,000)	Acc. unit	Yes

- **6085h: Quick stop deceleration**

This object is the configured deceleration used to stop the motor when the object "Quick stop code (605Ah)" is set to "2" or "6".

The quick stop deceleration is also used if the object "Fault reaction code (605Eh)" is set to "2".
The value is given in user-defined acceleration units.

Index	Sub-index	Name	Data type	Access	PDO	Value (Default)	Unit	Save
6085h	00h	Quick stop deceleration	UINT32	rww	Yes	1 to 1,000,000,000 (1,000)	Acc. unit	Yes

- **608Fh: Position encoder resolution**

This object is the configured encoder increments and the number of motor revolutions.
The control resolution is calculated by the following formula:

$$\text{Control resolution} = \frac{\text{Encoder increments}}{\text{Motor revolutions}}$$

Index	Sub-index	Name	Data type	Access	PDO	Value (Default)	Unit	Save
608Fh	Position encoder resolution							
	00h	Highest Sub-index Supported	UINT8	c	No	2	–	No
	01h	Encoder increments	UINT32	rww	Yes	1 to 65,535 (36,000)	–	Yes
	02h	Motor revolutions	UINT32	rww	Yes	1 to 65,535 (1)	–	Yes

Refer to the following for details on the control resolution.
- OPERATING MANUAL **BLV** Series **R** Type Function Edition

- **6091h: Gear ratio**

This object is the configured number of motor shaft revolutions and the number of driving shaft revolutions.
The gear ratio is calculated by the following formula:

$$\text{Gear ratio} = \frac{\text{Motor shaft revolutions}}{\text{driving shaft revolutions}}$$

Index	Sub-index	Name	Data type	Access	PDO	Value (Default)	Unit	Save
6091h	Gear ratio							
	00h	Highest sub-index supported	UINT8	c	No	2	–	No
	01h	Motor revolutions	UINT32	rw	No	1 to 1000 (1)	–	Yes
	02h	Shaft revolutions	UINT32	rw	No	1 to 1000 (1)	–	Yes

Refer to the following for details on the gear ratio.
- OPERATING MANUAL **BLV** Series **R** Type Function Edition

- **6098h: Homing method**

This object is the homing method.

Refer to the following section for details on the operations that are performed.

- "7.4.5 Homing method"

Index	Sub-index	Name	Data type	Access	PDO	Value (Default)	Unit	Save
6098h	00h	Homing method	INT8	rww	Yes	-1 to 37 (37)	-	Yes

Data Description

Value	Description
1	Homing on negative limit switch and index pulse
2	Homing on positive limit switch and index pulse
8	Homing on home switch and index pulse and starting in the positive direction
12	Homing on home switch and index pulse and starting in the negative direction
17	Homing on negative limit switch
18	Homing on positive limit switch
24	Homing on home switch and starting in the positive direction
28	Homing on home switch and starting in the negative direction
35, 37 *	Homing on current position
-1	Homing method of Orientalmotor specifications. Refer to the following for details on the operations. - OPERATING MANUAL BLV Series R Type Function Edition

* 35 and 37 perform the same action

- **6099h: Homing speeds**

This object defines the speeds that are used during homing.

The speeds are given in user-defined velocity units.

Index	Sub-index	Name	Data type	Access	PDO	Value (Default)	Unit	Save
6099h	Homing speeds							
	00h	Highest sub-index supported	UINT8	c	No	2	-	No
	00h	Speed during search for switch	UINT32	rww	Yes	1 to 4,000,000 (60)	-	Yes
	01h	Speed during search for zero	UINT32	rww	Yes	1 to 4,000,000 (30)	-	Yes

- **609Ah: Homing acceleration**

This object defines the acceleration that is used during homing.

The rate is given in user-defined acceleration units.

Index	Sub-index	Name	Data type	Access	PDO	Value (Default)	Unit	Save
609Ah	00h	Homing acceleration	UINT32	rw	Yes	1 to 1,000,000,000 (1,000)	Acc. unit	Yes

- **60A8h: SI unit position**

This object is the user-defined position units. This object does not reflect the writing value. It can be used to monitor the current user-defined position units.

Index	Sub-index	Name	Data type	Access	PDO	Value (Default)	Unit	Save
60A8h	00h	SI unit position	UINT32	rw	Yes	–	–	No

Data Description

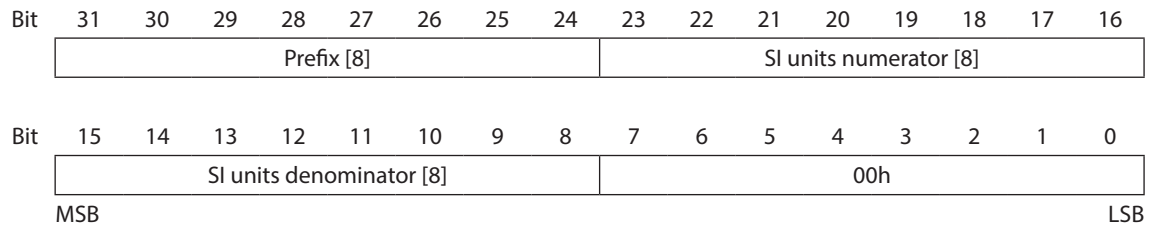

Prefix for SI units

Factor	Value	Factor	Value
10^6	06h	10^{-6}	FAh
10^5	05h	10^{-5}	FBh
10^4	04h	10^{-4}	FCh
10^3	03h	10^{-3}	FDh
10^2	02h	10^{-2}	FEh
10^1	01h	10^{-1}	FFh
10^0	00h		

SI units

Value	Unit symbol	Description
00h	–	Dimensionless
01h	m	Meter
41h	°	Degree
B4h	rev	Mechanical revolution
B5h	step	Encoder Increments
C0h	rev	Revolution (motor shaft)
D0h	rev	Revolution (driving shaft of the gearbox)
D1h	°	Degree (driving shaft of the gearbox)

- **60A9h: SI unit velocity**

This object is the user-defined velocity units. This object does not reflect the writing value. It can be used to monitor the current user-defined velocity units.

Index	Sub-index	Name	Data type	Access	PDO	Value (Default)	Unit	Save
60A9h	00h	SI unit velocity	UINT32	rw	Yes	–	–	No

Data Description

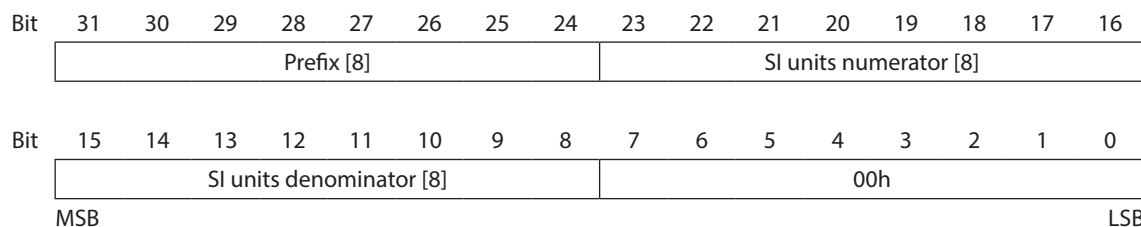

Prefix for SI units

Factor	Value	Factor	Value
10^6	06h	10^{-6}	FAh
10^5	05h	10^{-5}	FBh
10^4	04h	10^{-4}	FCh
10^3	03h	10^{-3}	FDh
10^2	02h	10^{-2}	FEh
10^1	01h	10^{-1}	FFh
10^0	00h		

SI units

Value	Unit symbol	Description
00h	–	Dimensionless or User-defined position unit
01h	m	Meter
03h	s	Second
41h	°	Degree
47h	min	Minute
B4h	rev	Mechanical revolution
B5h	inc	Encoder Increments
C0h	rev	Revolution (motor shaft)
D0h	rev	Revolution (driving shaft of the gearbox)
D1h	°	Degree (driving shaft of the gearbox)

- **60B8h: Touch probe function**

This object sets the touch probes.

Index	Sub-index	Name	Data type	Access	PDO	Value (Default)	Unit	Save
60B8h	00h	Touch probe function	UINT16	rww	Yes	0000h to FFFFh (3131h)	–	Yes

Data Description

Value	Description
0	0: Disables touch probe 1. 1: Enables touch probe 1.
1	0: Trigger first event of touch probe 1. 1: Continuous of touch probe 1.
2	0: Triggers on probe 1 input (USR-LAT-IN0 signal). 1: Triggers on ZSG-N signal.
3	Reserved
4	0: Stops sampling at positive edge of touch probe 1. 1: Starts sampling at positive edge of touch probe 1.
5	0: Stops sampling at negative edge of touch probe 1. 1: Starts sampling at negative edge of touch probe 1.
6 to 7	Reserved
8	0: Disables touch probe 2. 1: Enables touch probe 2.
9	0: Trigger first event of touch probe 2. 1: Continuous of touch probe 2.
10	0: Triggers on probe 2 input (USR-LAT-IN1 signal). 1: Triggers on ZSG-N signal.
11	Reserved
12	0: Stops sampling at positive edge of touch probe 2. 1: Starts sampling at positive edge of touch probe 2.
13	0: Stops sampling at negative edge of touch probe 2. 1: Starts sampling at negative edge of touch probe 2.
14 to 15	Reserved

- **60B9h: Touch probe status**

This object is the status of the touch probes.

Index	Sub-index	Name	Data type	Access	PDO	Value (Default)	Unit	Save
60B9h	00h	Touch probe status	UINT16	ro	Yes	–	–	No

Data Description

Value	Description
0	0: Touch probe 1 is disabled. 1: Touch probe 1 is enabled.
1	0: Touch probe 1 no positive edge value stored. 1: Touch probe 1 positive edge position stored.
2	0: Touch probe 1 no negative edge value stored. 1: Touch probe 1 negative edge position stored.
3 to 7	Reserved
8	0: Touch probe 2 is disabled. 1: Touch probe 2 is enabled.
9	0: Touch probe 2 no positive edge value stored. 1: Touch probe 2 positive edge position stored.
10	0: Touch probe 2 no negative edge value stored. 1: Touch probe 2 negative edge position stored.
11 to 15	Reserved

- **60BAh: Touch probe 1 positive edge**

This object provides the position value of the touch probe 1 at positive edge.
The value is given in user-defined position units.

Index	Sub-index	Name	Data type	Access	PDO	Value (Default)	Unit	Save
60BAh	00h	Touch probe 1 positive edge	INT32	ro	Yes	–	Pos. unit	No

- **60BBh: Touch probe 1 negative edge**

This object provides the position value of the touch probe 1 at negative edge.
The value is given in user-defined position units.

Index	Sub-index	Name	Data type	Access	PDO	Value (Default)	Unit	Save
60BBh	00h	Touch probe 1 negative edge	INT32	ro	Yes	–	Pos. unit	No

- **60BCh: Touch probe 2 positive edge**

This object provides the position value of the touch probe 2 at positive edge.
The value is given in user-defined position units.

Index	Sub-index	Name	Data type	Access	PDO	Value (Default)	Unit	Save
60BCh	00h	Touch probe 2 positive edge	INT32	ro	Yes	–	Pos. unit	No

- **60BDh: Touch probe 2 negative edge**

This object provides the position value of the touch probe 2 at negative edge.
The value is given in user-defined position units.

Index	Sub-index	Name	Data type	Access	PDO	Value (Default)	Unit	Save
60BDh	00h	Touch probe 2 negative edge	INT32	ro	Yes	–	Pos. unit	No

- **60D5h: Touch probe 1 positive edge counter**

This object provides a continuous counter that is incremented with each positive edge at touch probe 1. The counter is only valid if the touch probe input is enabled (60B8h bit 0 = 1). For single event measuring only the value of bit 0 is evaluated. For continuous measuring the value is an unsigned 16-bit value with overflow.

Index	Sub-index	Name	Data type	Access	PDO	Value (Default)	Unit	Save
60D5h	00h	Touch probe 1 positive edge counter	UINT16	ro	Yes	–	–	No

- **60D6h: Touch probe 1 negative edge counter**

This object provides a continuous counter that is incremented with each negative edge at touch probe 1. The counter is only valid if the touch probe input is enabled (60B8h bit 0 = 1). For single event measuring only the value of bit 0 shall be evaluated. For continuous measuring the value is an unsigned 16-bit value with overflow.

Index	Sub-index	Name	Data type	Access	PDO	Value (Default)	Unit	Save
60D6h	00h	Touch probe 1 negative edge counter	UINT16	ro	Yes	–	–	No

- **60D7h: Touch probe 2 positive edge counter**

This object provides a continuous counter that is incremented with each positive edge at touch probe 2. The counter is only valid if the touch probe input is enabled (60B8h bit 8 = 1). For single event measuring only the value of bit 0 shall be evaluated. For continuous measuring the value is an unsigned 16-bit value with overflow.

Index	Sub-index	Name	Data type	Access	PDO	Value (Default)	Unit	Save
60D7h	00h	Touch probe 2 positive edge counter	UINT16	ro	Yes	–	–	No

- **60D8h: Touch probe 2 negative edge counter**

This object provides a continuous counter that is incremented with each negative edge at touch probe 2. The counter is only valid if the touch probe input is enabled (60B8h bit 8 = 1). For single event measuring only the value of bit 0 shall be evaluated. For continuous measuring the value is an unsigned 16-bit value with overflow.

Index	Sub-index	Name	Data type	Access	PDO	Value (Default)	Unit	Save
60D8h	00h	Touch probe 2 negative edge counter	UINT16	ro	Yes	–	–	No

- **60E3h: Supported homing methods**

This object provides the supported homing methods of the drive.

Index	Sub-index	Name	Data type	Access	PDO	Value (Default)	Unit	Save
60E3h	Supported homing methods							
	00h	Highest Sub-index Supported	UINT8	c	No	11	–	No
	01h	1st supported homing method	INT8	ro	No	37	–	No
	02h	2nd supported homing method	INT8	ro	No	35	–	No
	03h	3rd supported homing method	INT8	ro	No	1	–	No
	04h	4th supported homing method	INT8	ro	No	2	–	No
	05h	5th supported homing method	INT8	ro	No	8	–	No
	06h	6th supported homing method	INT8	ro	No	12	–	No
	07h	7th supported homing method	INT8	ro	No	17	–	No
	08h	8th supported homing method	INT8	ro	No	18	–	No
	09h	9th supported homing method	INT8	ro	No	24	–	No
	0Ah	10th supported homing method	INT8	ro	No	28	–	No
0Bh	11th supported homing method	INT8	ro	No	–1	–	No	

● 60F2h: Positioning option code

The object is the positioning behavior in Profile Position mode.

Index	Sub-index	Name	Data type	Access	PDO	Value (Default)	Unit	Save
60F2h	00h	Positioning option code	UINT16	rww	Yes	0	-	No

Data Description

Bit	15	14	13	12	11	10	9	8	7	6	5	4	3	2	1	0
	PUSH	RSV [3]			IPOPT [4]				RADO	RRO	CIO	RO				
	MSB														LSB	

Bit	Notation	Meaning	Description
0, 1	RO	Relative option	Refer to following table.
2, 3	CIO	Change immediately option	Not supported.
4, 5	RRO	Request-response option	Not supported.
6, 7	RADO	Rotary axis direction option	Refer to following table.
8 to 11	IPOPT	IP option	Not supported.
12 to 14	RSV	Reserved	Reserved
15	PUSH	Push-motion	Refer to following table.

Bits in Controlword (6040h)	Bits in Positioning option code (60F2h)					Operation Mode	
	Abs / rel	Push-motion	Rotary axis direction option		Relative option		
	Bit 6	Bit 15	Bit 7	Bit 6	Bit 1		Bit 0
0	0	0	0	0	X	X	Absolute positioning/Wrap absolute positioning *
0	0	0	0	1	X	X	Wrap reverse direction absolute positioning *
0	0	0	1	0	X	X	Wrap forward direction absolute positioning *
0	0	0	1	1	X	X	Wrap proximity positioning *
0	1	0	0	0	X	X	Absolute positioning push-motion/Wrap absolute push-motion *
0	1	0	1	0	X	X	Wrap reverse direction push-motion *
0	1	0	1	1	X	X	Wrap forward direction push-motion *
0	1	0	1	1	X	X	Wrap proximity push-motion *
1	0	0	0	0	0	0	Incremental positioning (based on target position)
1	0	0	0	0	0	1	Incremental positioning (based on demand position)
1	0	0	0	1	1	0	Incremental positioning (based on actual position)
1	0	0	0	1	1	1	Reserved
1	1	0	0	0	0	0	Incremental positioning push-motion (based on target position)
1	1	0	0	0	0	1	Incremental positioning push-motion (based on command position)
1	1	0	0	1	1	0	Incremental positioning push-motion (based on actual position)
1	1	0	0	1	1	1	Reserved

* To do this, Object 607Bh(Position range limit) must have set.

Bits marked by an X are irrelevant.

Refer to the following for details on the operation mode.

- OPERATING MANUAL **BLV** Series **R** Type Function Edition

- **60F4h: Following error actual value**

This object provides the actual value of the following error.
The value is given in user-defined position units.

Index	Sub-index	Name	Data type	Access	PDO	Value (Default)	Unit	Save
60F4h	00h	Following error actual value	INT32	ro	Yes	-	Pos. unit	No

- **60FDh: Digital inputs**

This object provides the status of the driver and limit sensors.

Index	Sub-index	Name	Data type	Access	PDO	Value (Default)	Unit	Save
60FDh	00h	Digital inputs	UINT32	ro	Yes	-	-	No

Data Description

Bit	31	30	29	28	27	26	25	24	23	22	21	20	19	18	17	16
R-OUT [16]																

Bit	15	14	13	12	11	10	9	8	7	6	5	4	3	2	1	0	
RSV[12]													HWTO	HS	PLS	NLS	
MSB																LSB	

Bit	Notation	Meaning	Description
0	NLS	Negative limit switch	0: Negative limit switch not reached. 1: Negative limit switch reached.
1	PLS	Positive limit switch	0: Positive limit switch not reached. 1: Positive limit switch reached.
2	HS	Home switch	0: Home switch not reached. 1: Home switch reached.
3	HWTO	HWTO input status	0: Both the HWTO1 input and the HWTO2 input are not activated. 1: Either the HWTO1 input or the HWTO2 input is activated.
4 to 15	RSV	Reserved	Reserved
16 to 31	R-OUT	Remote output status	Output signals to R-OUT0 to R-OUT15 Details refer to following table.

Remote output status

Bit	Name	Default function	Bit	Name	Default function
16	R-OUT0	SON-MON	24	R-OUT8	SYS-BSY
17	R-OUT1	PLOOP-MON	25	R-OUT9	IN-POS
18	R-OUT2	TRQ-LMTD	26	R-OUT10	RDY-HOME-OPE
19	R-OUT3	RDY-DD-OPE	27	R-OUT11	RDY-FWRV-OPE
20	R-OUT4	ABSPEN	28	R-OUT12	RDY-SD-OPE
21	R-OUT5	STOP_R	29	R-OUT13	MOVE
22	R-OUT6	FREE_R	30	R-OUT14	VA
23	R-OUT7	ALM-A	31	R-OUT15	TLC

Refer to the following for details on the function assigned.
- OPERATING MANUAL **BLV** Series **R** Type Function Edition

- **60FEh: Digital outputs**

This object controls the remote I/O.

If it arranges the function assignment, it can control the direct output signal.

Index	Sub-index	Name	Data type	Access	PDO	Value (Default)	Unit	Save
60FEh	Digital outputs							
	00h	Highest Sub-index Supported	UINT8	c	No	1	-	No
	01h	Digital output – physical outputs	UINT32	rww	Yes	0000 0000h to FFFF FFFFh (0000 0000h)	-	No

Data Description

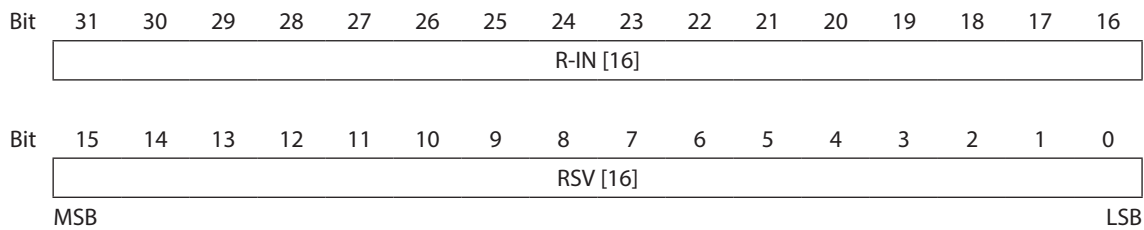

Bit	Notation	Meaning	Description
0 to 15	RSV	Reserved	Reserved
16 to 31	R-IN	Remote input signal	Input signals to R-IN0 to R-IN15 (Driver input command (2nd)). Details refer to following table.

Remote output status

Bit	Name	Default function	Bit	Name	Default function
16	R-IN0	S-ON	24	R-IN8	D-SEL0
17	R-IN1	PLOOP-MODE	25	R-IN9	D-SEL1
18	R-IN2	TRQ-LMT	26	R-IN10	D-SEL2
19	R-IN3	CLR	27	R-IN11	D-SEL3
20	R-IN4	QSTOP	28	R-IN12	D-SEL4
21	R-IN5	STOP	29	R-IN13	D-SEL5
22	R-IN6	FREE	30	R-IN14	D-SEL6
23	R-IN7	ALM-RST	31	R-IN15	D-SEL7

Refer to the following for details on the function assigned.

- OPERATING MANUAL **BLV** Series **R** Type Function Edition

- **60FFh: Target velocity (pv)**

This object is the target velocity for Profile Velocity Mode.

The value is given in user-defined velocity units.

Index	Sub-index	Name	Data type	Access	PDO	Value (Default)	Unit	Save
60FFh	00h	Target velocity (pv)	INT32	rww	Yes	-4000000 to 4000000 (0)	Vel. unit	No

● 6502h: Supported drive modes

This object provides information on the supported operation modes.

Index	Sub-index	Name	Data type	Access	PDO	Value (Default)	Unit	Save
6502h	00h	Supported drive modes	UINT32	ro	Yes	0000 0025h	–	No

Data Description

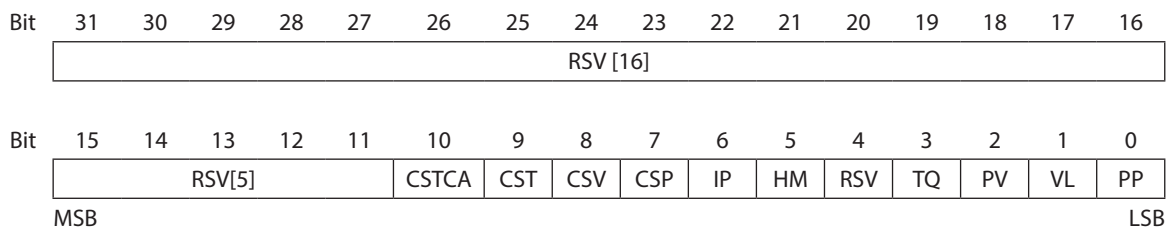

Bit	Notation	Operation Mode	Definition
0	PP	Profile position mode	1: Supported.
1	VL	Velocity mode	0: Not supported.
2	PV	Profile velocity mode	1: Supported.
3	TQ	Torque profile mode	0: Not supported.
4	RSV	Reserved	0: Reserved
5	HM	Homing mode	1: Supported.
6	IP	Interpolated position mode	0: Not supported.
7	CSP	Cyclic sync position mode	0: Not supported.
8	CSV	Cyclic sync velocity mode	0: Not supported.
9	CST	Cyclic sync torque mode	0: Not supported.
10	CSTCA	Cyclic sync torque mode with commutation angle	0: Not supported.
11 to 31	RSV	Reserved	0: Reserved

● 67FEh: Version number

Index	Sub-index	Name	Data type	Access	PDO	Value (Default)	Unit	Save
67FEh	00h	Version number	UINT32	ro	No	0004 0100h	–	No

Data Description

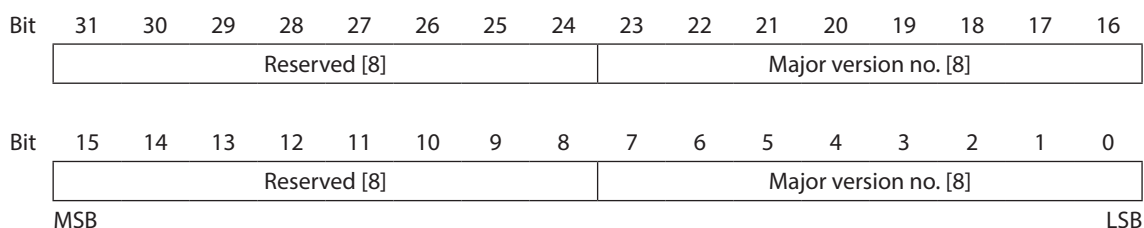

Bit	Notation	Definition
0 to 7	Sub version no.	0
8 to 15	Minor version no.	1
16 to 23	Minor version no.	4
24 to 31	Reserved	0

- **67FFh: Single device type**

The object defines the type of each device within one drive unit and its functionality.

Index	Sub-index	Name	Data type	Access	PDO	Value (Default)	Unit	Save
67FFh	00h	Single device type	UINT32	ro	No	0002 0192h	-	No

Data Description

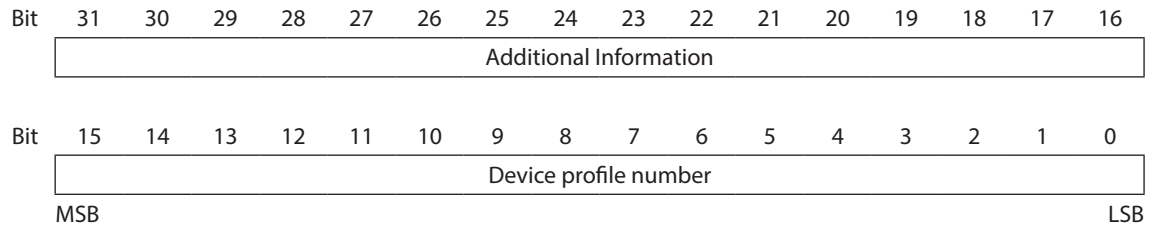

Additional Information: 2 (0002h) Servo Drive (Brushless motor driver)

Device profile number: 402 (0192h) DS402 drive profile

9 Appendix

9.1 Object list

Index	Sub	Name	Data type	Access	PDO	Range			Unit	Save
						Default	Lower Limit	Upper Limit		
1000h	00h	Device type	UINT32	c	No	0002 0192h	–	–	–	No
1001h	00h	Error register	UINT8	ro	No	–	–	–	–	No
1003h	Pre-defined error field									
	00h	Number of errors	UINT8	ro	No	0	0	10	–	No
	01h	Standard error field 1	UINT32	ro	No	0	–	–	–	No
	02h	Standard error field 2	UINT32	ro	No	0	–	–	–	No
	03h	Standard error field 3	UINT32	ro	No	0	–	–	–	No
	04h	Standard error field 4	UINT32	ro	No	0	–	–	–	No
	05h	Standard error field 5	UINT32	ro	No	0	–	–	–	No
	06h	Standard error field 6	UINT32	ro	No	0	–	–	–	No
	07h	Standard error field 7	UINT32	ro	No	0	–	–	–	No
	08h	Standard error field 8	UINT32	ro	No	0	–	–	–	No
	09h	Standard error field 9	UINT32	ro	No	0	–	–	–	No
0Ah	Standard error field 10	UINT32	ro	No	0	–	–	–	No	
1005h	00h	COB-ID SYNC message	UINT32	rw	No	0000 0080h	0000 0000h	FFFF FFFFh	–	Yes
1006h	00h	Communication cycle period	UINT32	rw	No	0	0	1,000,000	–	Yes
1008h	00h	Manufacturer device name	STRING	c	No	BLVD-KRD	–	–	–	No
1009h	00h	Manufacturer hardware version	STRING	c	No	–	–	–	–	No
100Ah	00h	Manufacturer software version	STRING	c	No	–	–	–	–	No
100Ch	00h	Guard time	UINT16	rw	No	0	0	65,535	ms	Yes
100Dh	00h	Life time factor	UINT8	rw	No	0	0	255	–	Yes
1010h	Store parameters									
	00h	Highest sub-index supported	UINT8	ro	No	2	–	–	–	No
	01h	Save all parameters	UINT32	rw	No	0000 0000h	0000 0000h	FFFF FFFFh	–	No
	02h	Save communication parameters	UINT32	rw	No	0000 0000h	0000 0000h	FFFF FFFFh	–	No

Index	Sub	Name	Data type	Access	PDO	Range			Unit	Save
						Default	Lower Limit	Upper Limit		
Restore default parameters										
1011h	00h	Highest sub-index supported	UINT8	ro	No	2	-	-	-	No
	01h	Restore all default parameters	UINT32	rw	No	0000 0000h	0000 0000h	FFFF FFFFh	-	No
	02h	Restore communication default parameters	UINT32	rw	No	0000 0000h	0000 0000h	FFFF FFFFh	-	No
1014h	00h	COB-ID EMCY	UINT32	rw	No	80h + Node-ID	0000 0000h	FFFF FFFFh	-	Yes
Consumer heartbeat time										
1016h	00h	Highest sub-index supported	UINT8	ro	No	1	-	-	-	No
	01h	Consumer heartbeat time	UINT32	rw	No	0000 0000h	0000 0000h	00FF FFFFh	-	Yes
1017h	00h	Producer heartbeat time	UINT16	rw	No	0	0	65,535	ms	Yes
Identity object										
1018h	00h	Highest sub-index supported	UINT8	ro	No	2	-	-	-	No
	01h	Vender ID	UINT32	ro	No	0000 02BEh	-	-	-	No
	02h	Product code	UINT32	ro	No	0000 13F7h	-	-	-	No
SDO server parameter										
1200h	00h	Highest sub-index supported	UINT8	ro	No	2	-	-	-	No
	01h	COB-ID client -> server (rx)	UINT32	ro	No	600h + Node-ID	0000 0000h	FFFF FFFFh	-	No
	02h	COB-ID server -> client (tx)	UINT32	ro	No	580h + Node-ID	0000 0000h	FFFF FFFFh	-	No
1st RPDO communication parameter										
1400h	00h	Highest sub-index supported	UINT8	ro	No	2	-	-	-	No
	01h	COB-ID used by RPDO	UINT32	rw	No	200h + Node-ID	0000 0000h	FFFF FFFFh	-	Yes
	02h	Transmission type	UINT8	rw	No	255	0	255	-	Yes
2nd RPDO communication parameter										
1401h	00h	Highest sub-index supported	UINT8	ro	No	2	-	-	-	No
	01h	COB-ID used by RPDO	UINT32	rw	No	300h + Node-ID	0000 0000h	FFFF FFFFh	-	Yes
	02h	Transmission type	UINT8	rw	No	255	0	255	-	Yes
3rd RPDO communication parameter										
1402h	00h	Highest sub-index supported	UINT8	ro	No	2	-	-	-	No
	01h	COB-ID used by RPDO	UINT32	rw	No	400h + Node-ID	0000 0000h	FFFF FFFFh	-	Yes
	02h	Transmission type	UINT8	rw	No	255	0	255	-	Yes

Index	Sub	Name	Data type	Access	PDO	Range			Unit	Save	
						Default	Lower Limit	Upper Limit			
1403h	4th RPDO communication parameter										
	00h	Highest sub-index supported	UINT8	ro	No	2	–	–	–	No	
	01h	COB-ID used by RPDO	UINT32	rw	No	500h + Node-ID	0000 0000h	FFFF FFFFh	–	Yes	
	02h	Transmission type	UINT8	rw	No	255	0	255	–	Yes	
1600h	1st RPDO mapping parameter										
	00h	Number of mapped application objects in PDO	UINT8	rw	No	1	0	4	–	Yes	
	01h	1st application object	UINT32	rw	No	6040 0010h	0000 0000h	FFFF FFFFh	–	Yes	
	02h	2nd application object	UINT32	rw	No	0000 0000h	0000 0000h	FFFF FFFFh	–	Yes	
	03h	3rd application object	UINT32	rw	No	0000 0000h	0000 0000h	FFFF FFFFh	–	Yes	
	04h	4th application object	UINT32	rw	No	0000 0000h	0000 0000h	FFFF FFFFh	–	Yes	
1601h	2nd RPDO mapping parameter										
	00h	Number of mapped application objects in PDO	UINT8	rw	No	2	0	4	–	Yes	
	01h	1st application object	UINT32	rw	No	6040 0010h	0000 0000h	FFFF FFFFh	–	Yes	
	02h	2nd application object	UINT32	rw	No	6060 0008h	0000 0000h	FFFF FFFFh	–	Yes	
	03h	3rd application object	UINT32	rw	No	0000 0000h	0000 0000h	FFFF FFFFh	–	Yes	
	04h	4th application object	UINT32	rw	No	0000 0000h	0000 0000h	FFFF FFFFh	–	Yes	
1602h	3rd RPDO mapping parameter										
	00h	Number of mapped application objects in PDO	UINT8	rw	No	2	0	4	–	Yes	
	01h	1st application object	UINT32	rw	No	6040 0010h	0000 0000h	FFFF FFFFh	–	Yes	
	02h	2nd application object	UINT32	rw	No	607A 0020h	0000 0000h	FFFF FFFFh	–	Yes	
	03h	3rd application object	UINT32	rw	No	0000 0000h	0000 0000h	FFFF FFFFh	–	Yes	
	04h	4th application object	UINT32	rw	No	0000 0000h	0000 0000h	FFFF FFFFh	–	Yes	

Index	Sub	Name	Data type	Access	PDO	Range			Unit	Save
						Default	Lower Limit	Upper Limit		
4th RPDO mapping parameter										
1603h	00h	Number of mapped application objects in PDO	UINT8	rw	No	2	0	4	–	Yes
	01h	1st application object	UINT32	rw	No	6040 0010h	0000 0000h	FFFF FFFFh	–	Yes
	02h	2nd application object	UINT32	rw	No	60FF 0020h	0000 0000h	FFFF FFFFh	–	Yes
	03h	3rd application object	UINT32	rw	No	0000 0000h	0000 0000h	FFFF FFFFh	–	Yes
	04h	4th application object	UINT32	rw	No	0000 0000h	0000 0000h	FFFF FFFFh	–	Yes
1st TPDO communication parameter										
1800h	00h	Highest sub-index supported	UINT8	ro	No	5	–	–	–	No
	01h	COB-ID used by TPDO	UINT32	rw	No	4000 0180h + Node-ID	0000 0000h	FFFF FFFFh	–	Yes
	02h	Transmission type	UINT8	rw	No	255	0	255	–	Yes
	03h	Inhibit time	UINT16	rw	No	50	0	65,535	100 µs	Yes
	04h	Reserved	–	–	–	–	–	–	–	–
	05h	Event timer	UINT16	rw	No	0	0	65,535	ms	Yes
2nd TPDO communication parameter										
1801h	00h	Highest sub-index supported	UINT8	ro	No	5	–	–	–	No
	01h	COB-ID used by TPDO	UINT32	rw	No	4000 0280h + Node-ID	0000 0000h	FFFF FFFFh	–	Yes
	02h	Transmission type	UINT8	rw	No	255	0	255	–	Yes
	03h	Inhibit time	UINT16	rw	No	50	0	65,535	100 µs	Yes
	04h	Reserved	–	–	–	–	–	–	–	–
	05h	Event timer	UINT16	rw	No	0	0	65,535	ms	Yes
3rd TPDO communication parameter										
1802h	00h	Highest sub-index supported	UINT8	ro	No	5	–	–	–	No
	01h	COB-ID used by TPDO	UINT32	rw	No	4000 0380h + Node-ID	0000 0000h	FFFF FFFFh	–	Yes
	02h	Transmission type	UINT8	rw	No	1	0	255	–	Yes
	03h	Inhibit time	UINT16	rw	No	50	0	65,535	100 µs	Yes
	04h	Reserved	–	–	–	–	–	–	–	–
	05h	Event timer	UINT16	rw	No	0	0	65,535	ms	Yes
4th TPDO communication parameter										
1803h	00h	Highest sub-index supported	UINT8	ro	No	5	–	–	–	No
	01h	COB-ID used by TPDO	UINT32	rw	No	4000 0480h + Node-ID	0000 0000h	FFFF FFFFh	–	Yes
	02h	Transmission type	UINT8	rw	No	1	0	255	–	Yes
	03h	Inhibit time	UINT16	rw	No	50	0	65,535	100 µs	Yes
	04h	Reserved	–	–	–	–	–	–	–	–
	05h	Event timer	UINT16	rw	No	0	0	65,535	ms	Yes

Index	Sub	Name	Data type	Access	PDO	Range			Unit	Save
						Default	Lower Limit	Upper Limit		
1A00h	1st TPDO mapping parameter									
	00h	Number of mapped application objects in TPDO	UINT8	ro	No	1	0	4	-	No
	01h	1st application object	UINT32	rw	No	6041 0010h	0000 0000h	FFFF FFFFh	-	Yes
	02h	2nd application object	UINT32	rw	No	0000 0000h	0000 0000h	FFFF FFFFh	-	Yes
	03h	3rd application object	UINT32	rw	No	0000 0000h	0000 0000h	FFFF FFFFh	-	Yes
04h	4th application object	UINT32	rw	No	0000 0000h	0000 0000h	FFFF FFFFh	-	Yes	
1A01h	2nd TPDO mapping parameter									
	00h	Number of mapped application objects in TPDO	UINT8	ro	No	2	0	4	-	No
	01h	1st application object	UINT32	rw	No	6041 0010h	0000 0000h	FFFF FFFFh	-	Yes
	02h	2nd application object	UINT32	rw	No	6061 0008h	0000 0000h	FFFF FFFFh	-	Yes
	03h	3rd application object	UINT32	rw	No	0000 0000h	0000 0000h	FFFF FFFFh	-	Yes
04h	4th application object	UINT32	rw	No	0000 0000h	0000 0000h	FFFF FFFFh	-	Yes	
1A02h	3rd TPDO mapping parameter									
	00h	Number of mapped application objects in TPDO	UINT8	ro	No	2	0	4	-	No
	01h	1st application object	UINT32	rw	No	6041 0010h	0000 0000h	FFFF FFFFh	-	Yes
	02h	2nd application object	UINT32	rw	No	6064 0020h	0000 0000h	FFFF FFFFh	-	Yes
	03h	3rd application object	UINT32	rw	No	0000 0000h	0000 0000h	FFFF FFFFh	-	Yes
04h	4th application object	UINT32	rw	No	0000 0000h	0000 0000h	FFFF FFFFh	-	Yes	
1A03h	4th TPDO mapping parameter									
	00h	Number of mapped application objects in TPDO	UINT8	ro	No	2	0	4	-	No
	01h	1st application object	UINT32	rw	No	6041 0010h	0000 0000h	FFFF FFFFh	-	Yes
	02h	2nd application object	UINT32	rw	No	606C 0020h	0000 0000h	FFFF FFFFh	-	Yes
	03h	3rd application object	UINT32	rw	No	0000 0000h	0000 0000h	FFFF FFFFh	-	Yes
04h	4th application object	UINT32	rw	No	0000 0000h	0000 0000h	FFFF FFFFh	-	Yes	

Index	Sub	Name	Data type	Access	PDO	Range			Unit	Save
						Default	Lower Limit	Upper Limit		
402Ch	00h	Direct data operation operation data number	INT16	rww	Yes	0	0	255	-	No
402Dh	00h	Direct data operation operation type	UINT8	rww	Yes	0	0	255	-	No
402Eh	00h	Direct data operation position	INT32	rww	Yes	0	-2,147,483,648	2,147,483,647	Pos. unit	No
402Fh	00h	Direct data operation operating velocity	INT32	rww	Yes	0	-4,000,000	4,000,000	Vel. unit	No
4030h	00h	Direct data operation acceleration rate	INT32	rww	Yes	1,000	1	1,000,000,000	Acc. unit (MS)	No
4031h	00h	Direct data operation deceleration rate	INT32	rww	Yes	1,000	1	1,000,000,000	Acc. unit (MS)	No
4032h	00h	Direct data operation torque limiting value	INT16	rww	Yes	10,000	0	10,000	0.1%	No
4033h	00h	Direct data operation trigger	INT32	rww	Yes	0	-7	2,147,418,131	-	No
4034h	00h	Direct data operation forwarding destination	UINT8	rww	Yes	0	0	1	-	No
403Ah	00h	Driver input command (2nd)	UINT32	rww	Yes	0000 0000h	0000 0000h	FFFF FFFFh	-	No
403Ch	00h	Driver input command (automatic OFF)	UINT32	rww	Yes	0000 0000h	0000 0000h	FFFF FFFFh	-	No
403Dh	00h	NET selection data number	UINT32	rww	Yes	0	0	255	-	No
403Eh	00h	Driver input command	UINT32	rww	Yes	0000 0000h	0000 0000h	FFFF FFFFh	-	No
403Fh	00h	Driver output status	UINT32	ro	Yes	-	-	-	-	No
404Bh	00h	Target position (User-defined position unit)	INT32	ro	Yes	-	-	-	Pos. unit	No
404Ch	00h	Demand position (User-defined position unit)	INT32	ro	Yes	-	-	-	Pos. unit	No
404Dh	00h	Actual position (User-defined position unit)	INT32	ro	Yes	-	-	-	Pos. unit	No
404Eh	00h	Target velocity (User-defined velocity unit)	INT32	ro	Yes	-	-	-	Vel. unit	No
404Fh	00h	Demand velocity (User-defined velocity unit)	INT32	ro	Yes	-	-	-	Vel. unit	No

Index	Sub	Name	Data type	Access	PDO	Range			Unit	Save
						Default	Lower Limit	Upper Limit		
4050h	00h	Actual velocity (User-defined velocity unit)	INT32	ro	Yes	-	-	-	Vel. unit	No
4056h	00h	Present communication error	UINT8	ro	Yes	-	-	-	-	No
406Bh	00h	Torque monitor	INT16	ro	Yes	-	-	-	0.1%	No
406Ch	00h	Load factor monitor	INT32	ro	Yes	-	-	-	0.1%	No
406Dh	00h	Cumulative load monitor	UINT32	ro	Yes	-	-	-	-	No
4070h	00h	Next data number	INT16	ro	Yes	-	-	-	-	No
4071h	00h	Loop origin data number	INT16	ro	Yes	-	-	-	-	No
4072h	00h	Loop count	UINT32	ro	Yes	-	-	-	-	No
4073h	00h	Position deviation	INT32	ro	Yes	-	-	-	Pos. unit	No
4075h	00h	Speed deviation	INT32	ro	Yes	-	-	-	Vel. unit	No
407Ah	00h	Tripmeter 1	INT32	ro	Yes	-	-	-	0.1 krev	No
407Bh	00h	Information status 1	UINT32	ro	Yes	-	-	-	-	No
407Ch	00h	Driver temperature	INT16	ro	Yes	-	-	-	0.1°C	No
407Dh	00h	Motor temperature	INT16	ro	Yes	-	-	-	0.1°C	No
407Eh	00h	Odometer	UINT32	ro	Yes	-	-	-	0.1 krev	No
407Fh	00h	Tripmeter 0	UINT32	ro	Yes	-	-	-	0.1 krev	No
409Bh	00h	Main power supply current	INT32	ro	Yes	-	-	-	0.001 A	No
409Ch	00h	Power consumption	UINT32	ro	Yes	-	-	-	0.1W	No
409Dh	00h	Energy consumption	UINT32	ro	Yes	-	-	-	0.001 Wh	No
409Eh	00h	User energy consumption	UINT32	ro	Yes	-	-	-	Wh	No
409Fh	00h	Total energy consumption	UINT32	ro	Yes	-	-	-	Wh	No
40A1h	00h	Total uptime	UINT32	ro	Yes	-	-	-	min.	No
40A2h	00h	Number of boots	UINT32	ro	Yes	-	-	-	-	No
40A3h	00h	Inverter voltage	INT16	ro	Yes	-	-	-	0.1V	No
40A4h	00h	Main power supply voltage	INT16	ro	Yes	-	-	-	0.1V	No
40A9h	00h	Continuous uptime	UINT32	ro	Yes	-	-	-	ms	No
40AAh	00h	RS-485 communication reception byte counter	UINT32	ro	Yes	-	-	-	-	No

Index	Sub	Name	Data type	Access	PDO	Range			Unit	Save
						Default	Lower Limit	Upper Limit		
40ABh	00h	RS-485 communication transmission byte counter	UINT32	ro	Yes	-	-	-	-	No
40C0h	00h	Alarm reset	UINT8	rww	Yes	0	0	2	-	No
40C2h	00h	Clear alarm history	UINT8	rww	Yes	0	0	2	-	No
40C5h	00h	P-PRESET execution	UINT8	rww	Yes	0	0	2	-	No
40C6h	00h	Configuration	UINT8	rww	Yes	0	0	2	-	No
40CDh	00h	Clear latch information	UINT8	rww	Yes	0	0	2	-	No
40CEh	00h	Clear sequence history	UINT8	rww	Yes	0	0	2	-	No
40D0h	00h	Clear ETO	UINT8	rww	Yes	0	0	2	-	No
40D1h	00h	ZSG-PRESET	UINT8	rww	Yes	0	0	2	-	No
40D2h	00h	Clear ZSG-PRESET	UINT8	rww	Yes	0	0	2	-	No
40D3h	00h	Clear information	UINT8	rww	Yes	0	0	2	-	No
40D6h	00h	Clear user energy consumption	UINT8	rww	Yes	0	0	2	-	No
40D7h	00h	Clear tripmeter 0	UINT8	rww	Yes	0	0	2	-	No
40D8h	00h	Clear tripmeter 1	UINT8	rww	Yes	0	0	2	-	No
4148h	00h	Permission of absolute positioning without setting absolute coordinates	UINT8	rww	Yes	0	0	1	-	No
415Fh	00h	JOG/HOME Torque limit value	UINT16	rww	Yes	10,000	0	10,000	0.1%	Yes
4160h	00h	(HOME) Homing mode	UINT8	rww	Yes	1	0	3	-	Yes
4163h	00h	(HOME) Starting velocity	UINT32	rww	Yes	30	1	4,000,000	Vel. unit	Yes
4169h	00h	(HOME) Backward steps in 2 sensor homeseeking	UINT32	rww	Yes	18,000	0	8,388,607	Pos. unit	Yes
4186h	00h	Stopping timeout at alarm generation	UINT16	rww	Yes	3,000	0	10,000	ms	Yes
41CAh	00h	WRAP setting	UINT8	rww	Yes	1	1	2	-	Yes
4735h	00h	Custom stopping rate	UINT32	rww	Yes	1,000	1	1,000,000,000	Acc. unit	Yes
4736h	00h	Custom stopping time	UINT32	rww	Yes	1,000	1	1,000,000,000	ms	Yes
603Fh	00h	Error code	UINT16	ro	Yes	-	-	-	-	No
6040h	00h	Controlword	UINT16	rww	Yes	0004h	0000h	FFFFh	-	No
6041h	00h	Statusword	UINT16	ro	Yes	-	-	-	-	No
605Ah	00h	Quick stop option code	INT16	rw	No	2	-3	6	-	Yes
605Bh	00h	Shutdown option code	INT16	rw	No	0	0	1	-	Yes

Index	Sub	Name	Data type	Access	PDO	Range			Unit	Save
						Default	Lower Limit	Upper Limit		
605Ch	00h	Disable operation option code	INT16	rw	No	1	0	1	–	Yes
605Dh	00h	Halt option code	INT16	rw	No	1	–3	2	–	Yes
605Eh	00h	Fault reaction option code	INT16	rw	No	2	0	2	–	Yes
6060h	00h	Modes of operation	INT8	rww	Yes	3	0	6	–	Yes
6061h	00h	Modes of operation display	INT8	ro	Yes	–	–	–	–	No
6062h	00h	Position demand value	INT32	ro	Yes	–	–	–	Pos. unit	No
6064h	00h	Position actual value	INT32	ro	Yes	–	–	–	Pos. unit	No
6065h	00h	Following error window	UINT32	rww	Yes	100,800	0	10,000,000	Pos. unit	Yes
6067h	00h	Position window	UINT32	rww	Yes	18	0	65,535	Pos. unit	Yes
606Bh	00h	Velocity demand value	INT32	ro	Yes	–	–	–	Vel. unit	No
606Ch	00h	Velocity actual value	INT32	ro	Yes	–	–	–	Vel. unit	No
606Dh	00h	Velocity window	UINT16	rww	Yes	15	1	65,535	Vel. unit	Yes
606Fh	00h	Velocity threshold	UINT16	rww	Yes	15	1	65,535	Vel. unit	Yes
6072h	00h	Max torque	UINT16	rww	Yes	10,000	0	10,000	0.1%	Yes
6077h	00h	Torque actual value	INT16	ro	Yes	–	–	–	0.1%	No
607Ah	00h	Target position	INT32	rww	Yes	0	–2,147,483,648	2,147,483,647	Pos. unit	No
Position range limit										
607Bh	00h	Highest Sub-index Supported	UINT8	c	No	2	–	–	–	No
	01h	Min position range limit	INT32	rww	Yes	0	–2,147,483,648	0	Pos. unit	Yes
	02h	Max position range limit	INT32	rww	Yes	0	0	2,147,483,647	Pos. unit	Yes
607Ch	00h	Home offset	INT32	rww	Yes	0	–2,147,483,648	2,147,483,647	Pos. unit	Yes
Software position limit										
607Dh	00h	Highest Sub-index Supported	UINT8	c	No	2	–	–	–	No
	01h	Min position limit	INT32	rww	Yes	0	–2,147,483,648	2,147,483,647	Pos. unit	Yes
	02h	Max position limit	INT32	rww	Yes	0	–2,147,483,648	2,147,483,647	Pos. unit	Yes
6081h	00h	Profile velocity	UINT32	rww	Yes	1	1	4,000,000	Pos. unit	Yes
6082h	00h	End velocity	UINT32	rww	Yes	0	0	4,000,000	Vel. unit	Yes
6083h	00h	Profile acceleration	UINT32	rww	Yes	1,000	1	1,000,000,000	Acc. unit	Yes

Index	Sub	Name	Data type	Access	PDO	Range			Unit	Save
						Default	Lower Limit	Upper Limit		
6084h	00h	Profile deceleration	UINT32	rww	Yes	1,000	1	1,000,000,000	Acc. unit	Yes
6085h	00h	Quick stop deceleration	UINT32	rww	Yes	1,000	1	1,000,000,000	Acc. unit	Yes
Position encoder resolution										
608Fh	00h	Highest Sub-index Supported	UINT8	c	No	2	-	-	-	No
	01h	Encoder increments	UINT32	rww	Yes	36,000	1	65,535	-	Yes
	02h	Motor revolutions	UINT32	rww	Yes	1	1	65,535	-	Yes
Gear ratio										
6091h	00h	Highest sub-index supported	UINT8	c	No	2	-	-	-	No
	01h	Motor revolutions	UINT32	rw	No	1	1	1,000	-	Yes
	02h	Shaft revolutions	UINT32	rw	No	1	1	1,000	-	Yes
6098h	00h	Homing method	INT8	rww	Yes	37	-1	37	-	Yes
Homing speeds										
6099h	00h	Highest sub-index supported	UINT8	c	No	2	-	-	-	No
	01h	Speed during search for switch	UINT32	rww	Yes	60	1	4,000,000	Vel. unit	Yes
	02h	Speed during search for zero	UINT32	rww	Yes	30	1	4,000,000	Vel. unit	Yes
609Ah	00h	Homing acceleration	UINT32	rww	Yes	1,000	1	1,000,000,000	Acc. unit	Yes
60A8h	00h	SI unit position	UINT32	rw	Yes	-	-	-	-	No
60A9h	00h	SI unit velocity	UINT32	rw	Yes	-	-	-	-	No
60B8h	00h	Touch probe function	UINT16	rww	Yes	0000h	0000h	FFFFh	-	Yes
60B9h	00h	Touch probe status	UINT16	ro	Yes	-	-	-	-	No
60BAh	00h	Touch probe 1 positive edge	INT32	ro	Yes	-	-	-	Pos. unit	No
60BBh	00h	Touch probe 1 negative edge	INT32	ro	Yes	-	-	-	Pos. unit	No
60BCh	00h	Touch probe 2 positive edge	INT32	ro	Yes	-	-	-	Pos. unit	No
60BDh	00h	Touch probe 2 negative edge	INT32	ro	Yes	-	-	-	Pos. unit	No
60D5h	00h	Touch probe 1 positive edge counter	UINT16	ro	Yes	-	-	-	-	No
60D6h	00h	Touch probe 1 negative edge counter	UINT16	ro	Yes	-	-	-	-	No
60D7h	00h	Touch probe 2 positive edge counter	UINT16	ro	Yes	-	-	-	-	No
60D8h	00h	Touch probe 2 negative edge counter	UINT16	ro	Yes	-	-	-	-	No

Index	Sub	Name	Data type	Access	PDO	Range			Unit	Save
						Default	Lower Limit	Upper Limit		
Supported homing methods										
60E3h	00h	Highest Sub-index Supported	UINT8	c	No	11	-	-	-	No
	01h	1st supported homing method	INT8	ro	No	37	-	-	-	No
	02h	2nd supported homing method	INT8	ro	No	35	-	-	-	No
	03h	3rd supported homing method	INT8	ro	No	1	-	-	-	No
	04h	4th supported homing method	INT8	ro	No	2	-	-	-	No
	05h	5th supported homing method	INT8	ro	No	8	-	-	-	No
	06h	6th supported homing method	INT8	ro	No	12	-	-	-	No
	07h	7th supported homing method	INT8	ro	No	17	-	-	-	No
	08h	8th supported homing method	INT8	ro	No	18	-	-	-	No
	09h	9th supported homing method	INT8	ro	No	24	-	-	-	No
	0Ah	10th supported homing method	INT8	ro	No	28	-	-	-	No
	0Bh	11th supported homing method	INT8	ro	No	-1	-	-	-	No
60F2h	00h	Positioning option code	UINT16	rww	Yes	0	0000h	FFFFh	-	No
60F4h	00h	Following error actual value	INT32	ro	Yes	-	-	-	Pos. unit	No
60FDh	00h	Digital inputs	UINT32	ro	Yes	-	-	-	-	No
Digital output										
60FEh	00h	Highest Sub-index Supported	UINT8	c	No	1	-	-	-	No
	01h	Digital output-physical outputs	UINT32	rww	Yes	0000 0000h	0000 0000h	FFFF FFFFh	-	No
60FFh	00h	Target velocity (pv)	INT32	rww	Yes	0	-4,000,000	4,000,000	Vel. unit	No
6502h	00h	Supported drive modes	UINT32	ro	Yes	0000 0025h	-	-	-	No
67FEh	00h	Version number	UINT32	ro	No	0004 0100h	-	-	-	No
67FFh	00h	Single device type	UINT32	ro	No	0002 0192h	-	-	-	No

9.2 Specifications

Electrical characteristics	In conformance with ISO 11898 Use the CAN-Bus cable.
Communication protocol	CANopen
Communication profile	In conformance with CiA DS301 Version 4.2.0
Device profile	In conformance with CiA DSP402 Version 4.0.0
Node ID	1 to 127
Bitrate	Selectable from 1000, 800, 500(default), 250, 125, 50, 20, and 10 kbps
Maximum bus length	25 m (82 ft.) [maximum bus length at 1 Mbps]
Communication objects	NMT (Network Management) SDO (Service Data Object: 1 SDO server) PDO (Process Data Object: 4 Receive-PDO, 4 Transmit-PDO) EMCY (Emergency Object) SYNC (Synchronization Object)
Operation modes	Profile velocity mode (pv) Profile position mode (pp) Homing mode (hm)

• Please contact your nearest Oriental Motor office for further information.

ORIENTAL MOTOR U.S.A. CORP.
Technical Support Tel:800-468-3982
8:30am EST to 5:00pm PST (M-F)
www.orientalmotor.com

ORIENTAL MOTOR (EUROPA) GmbH
Schiessstraße 44, 40549 Düsseldorf, Germany
Technical Support Tel:00 800/22 55 66 22
www.orientalmotor.de

ORIENTAL MOTOR (UK) LTD.
Unit 5 Faraday Office Park, Rankine Road,
Basingstoke, Hampshire RG24 8QB UK
Tel:+44-1256347090
www.oriental-motor.co.uk

ORIENTAL MOTOR (FRANCE) SARL
Tel:+33-1 47 86 97 50
www.orientalmotor.fr

ORIENTAL MOTOR ITALIA s.r.l.
Tel:+39-02-93906347
www.orientalmotor.it

ORIENTAL MOTOR ASIA PACIFIC PTE. LTD.
Singapore
Tel:1800-842-0280
www.orientalmotor.com.sg

ORIENTAL MOTOR (MALAYSIA) SDN. BHD.
Tel:1800-806-161
www.orientalmotor.com.my

ORIENTAL MOTOR (THAILAND) CO., LTD.
Tel:1800-888-881
www.orientalmotor.co.th

ORIENTAL MOTOR (INDIA) PVT. LTD.
Tel:1800-120-1995 (For English)
1800-121-4149 (For Hindi)
www.orientalmotor.co.in

TAIWAN ORIENTAL MOTOR CO., LTD.
Tel:0800-060708
www.orientalmotor.com.tw

SHANGHAI ORIENTAL MOTOR CO., LTD.
Tel:400-820-6516
www.orientalmotor.com.cn

INA ORIENTAL MOTOR CO., LTD.
Korea
Tel:080-777-2042
www.inaom.co.kr

ORIENTAL MOTOR CO., LTD.
4-8-1 Higashiueno, Taito-ku, Tokyo
110-8536 Japan
Tel:+81-3-6744-0361
www.orientalmotor.co.jp