

Small Robots OVR 4-Axis Articulated Operating Manual

WM-0002-2E

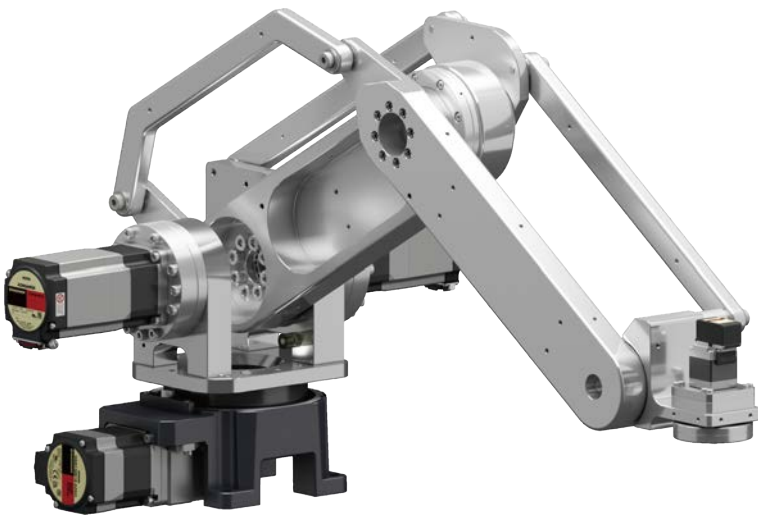

Thank you for purchasing an Oriental Motor product. This manual describes product handling procedures and safety precautions. Please read the manual thoroughly to ensure safe operation.

- Only qualified personnel of electrical and mechanical engineering should work with the product.
- The product described in this manual is designed and manufactured to be incorporated into general industrial equipment. Do not use it for any other purpose. Oriental Motor Co., Ltd. is not responsible for any compensation for damage caused through failure to observe this warning.
- Read the section "[Safety precautions](#)" on [page 3](#) thoroughly before using the product. In addition, be sure to observe the contents described in warning, caution, and note in this manual.

Table of contents

Safety precautions	3
WARNING	3
CAUTION	6
Preparation	8
Checking the product	8
How to identify the product model	8
Products that can be combined	8
Information about nameplate	8
Names of parts	9
Rotation limit mechanical stopper	10
Installation of robot	11
Installation location	11
Unpacking method	11
Installation method	12
Installation of the end effector	14
Wiring example	14
Connection of the connector type motor	15
Setup	18
Setup method	18
Origin posture at setup	18
Maintenance	20
Inspection	20
Warranty	21
Disposal	21
Specifications	22
Product specifications	22
General specifications	22
Accessories	23
Wrist bending axis mounting bracket	23

Safety precautions

The precautions described below are intended to ensure the safe and proper use of the product and to prevent the user and other personnel from exposure to the risk of injury. Use the product only after carefully reading and fully understanding these instructions.

In regard to a robot, it is prohibited to start operating the robot (i.e., to operate the device in accordance with the specified purpose) when the machine in which the robot is incorporated does not meet the relevant safety standards. The factory safety manager or safety personnel in charge of the applicable machine must ensure that the machine is operated only by qualified personnel who has expert knowledge on safety, and thereby prevent injury or damage to the machine.

The term “qualified personnel” refers to persons who have received the necessary training or education and have pertinent experience; who are familiar with the relevant standards and regulations; who are authorized by the factory safety manager to engage in the necessary activities; and who have the ability to discern and prevent potential dangers.

Warning

Handling the product without observing the instructions that accompany a “WARNING” symbol may result in serious injury or death.

Caution

Handling the product without observing the instructions that accompany a “CAUTION” symbol may result in injury or property damage.

Note

The items under this heading contain important handling instructions that the user should observe to ensure safe use of the product.

Tip

The items under this heading contain related information and contents to gain a further understanding of the text in this manual.

WARNING

General

- Never use the product for equipment in connection with the maintenance or management of human life or health.
- Do not use the product in explosive or corrosive environments, in the presence of flammable gases, in areas subjected to splashing water, or near combustible materials. Doing so may result in fire or injury.

- Assign qualified personnel having expert knowledge on electrical and mechanical engineering as well as safety to the task of installing, wiring, operating/controlling, inspecting and troubleshooting the product. Handling by unqualified personnel may result in fire, injury, or damage to equipment.
- Conduct a risk assessment in a state where all parts and components including the product have been installed in the equipment. Failure to do so may result in injury or damage to equipment.
- Provide a safety cage that meets the safety distance specified in ISO 13857 so that an operator or other personnel does not enter the movable range of the product while the equipment is operating. Failure to do so may result in injury.
- When teaching, adjusting, or inspecting the product inside the safety cage, take appropriate safety measures according to the results of the risk assessment of the entire equipment. Failure to do so may result in injury.
- Provide appropriate safety measures so that the entire equipment will operate safely in the event of a system failure or malfunction. Failure to do so may result in injury.
- Provide an emergency stop function for the equipment. Failure to do so may result in injury.
- The function and performance of the safety-related control system are appropriately determined according to the results of the risk assessment of the entire equipment. This may result in injury.
- Do not disassemble any components other than those specified for the motor replacement work. Also, do not modify the product. Doing so may result in injury or damage to equipment.
- Use the product in a condition where the entire equipment complies with relevant international standards such as ISO 12100, ISO 10218-1, ISO 10218-2, national standards, and legal regulations such as occupational health and safety required in each country. Failure to do so may result in injury or damage to equipment.
- Do not install, connect, or inspect/troubleshoot the product while the power is on. When working with the power on state, provide work rules in accordance with the Ordinance on Industrial Safety and Health and take appropriate safety measures. Failure to do so may result in fire, injury, or damage to equipment.
- Do not allow your hands to be caught in moving parts of the product. Doing so may result in injury or damage to equipment.

Installation and wiring

- Since the product is very heavy, make sure that two or more people work together to perform the necessary tasks when transporting or installing it. This may result in injury.
- Wear a helmet, safety shoes, gloves, or other protective equipment when transporting or installing the product. Failure to do so may result in injury.
- Be sure to secure the product itself according to the instructions. Failure to do so may result in injury or damage to equipment.
- Be sure to wire and connect according to the instructions. Failure to do so may result in fire or damage to equipment.
- Install an external fuse, if necessary, to prevent ignition due to a large amount of current flowing from the power supply side.

- Do not pull or forcibly bend the arm section or cable. Also, do not lift the product by holding the arm section or cable. Doing so may result in injury or damage to equipment.

Warning for transportation of heavy load

- Make sure that two or more people work together to perform the necessary tasks or use a crane when transporting the product.
- When working with two or more people, clarify the relationship and roles of the primary worker and assistant worker, and transport the product while communicating with each other to ensure safety.
- When using a crane, do not hang loads exceeding the rated load of the crane.
- Consider the cutting load and safety factor of the lifting tool, use a lifting tool suitable for transporting the product. Also check for any damage to the lifting tools.
- Do not ride on loads suspended by the crane.
- Do not leave a crane unattended with a suspended load.
- Do not enter under a crane with a suspended load.

Operation

- Before operating a robot, check the condition of the surrounding area to ensure safety. This may cause injury or damage to equipment.
- Take appropriate safety measures when placing the motor in a non-excitation state. Failure to do so may result in injury or damage to equipment.
- Do not turn off the power or input a signal to place the motor in a non-excitation state during operation. The robot may move unexpectedly, causing injury or damage to equipment.
- When turning on the driver power, make sure there is no signal input from the host controller. The product may start operating unintentionally, causing injury or damage to equipment.
- When operating the product after the driver power supply is turned on or the power to the motor is turned off, adjust the position at low speed to ensure safety. Failure to do so may result in injury or damage to equipment.
- Turn off the power supply of the driver in the event of a power failure. Otherwise, the product may start suddenly when the power is restored, causing injury or damage to equipment.
- If an abnormality occurs in the product, immediately stop operation and turn off the power to the motor that drives the product. Failure to do so may result in injury or damage to equipment.

Maintenance and inspection

- Perform the pre-work (daily) inspection and periodic inspection according to the instructions in this manual, and check that there are no abnormalities in the product and related equipment before working. Failure to do so may result in injury or damage to equipment.
- If it is necessary to replace the motor for maintenance, contact your nearest sales office.

CAUTION

- Do not use the product beyond its specifications. Doing so may result in injury or damage to equipment.
- Keep the area around the product free of combustible materials. Failure to do so may result in fire or a skin burn(s).
- Do not leave anything around the product that would obstruct ventilation. Doing so may result in damage to equipment.
- Use a driver and cable that are connected to the motor only in the specified combination. Failure to do so may result in fire, injury, or damage to equipment.
- When conducting the insulation resistance measurement or the dielectric strength test, be sure to separate the connection between the product and the driver. Failure to do so may result in damage to equipment.
- Take measures against static electricity when handling. Static electricity may cause the encoder (ABZO sensor) of the motor that drives the product or the driver to malfunction or be damaged. This may result in injury or damage to equipment.
- Keep the encoder (ABZO sensor) of the motor away from a strong magnetic field. This may damage to the encoder (ABZO sensor) or cause the product to malfunction. Injury or damage to equipment may result.
- Stop operation if abnormal noise or vibration occurs during operation. Failure to do so may result in injury or damage to equipment.
- Since the motor surface temperature may exceed 70 °C (158 °F) even under normal operating conditions, if the operator is allowed to approach the motor, affix a warning label shown in the figure on a conspicuous place. The surface is hot, and this may cause a skin burn(s).



- To protect the encoder (ABZO sensor), use the motor in a condition where the motor surface temperature does not exceed 80 °C (176 °F). Failure to do so may result in damage to equipment.
- Make sure not to apply a strong shock to the encoder (ABZO sensor) of the motor. This may damage to the encoder (ABZO sensor) and cause the product to malfunction, resulting in damage to the equipment. The label shown in the figure is affixed on the motor.

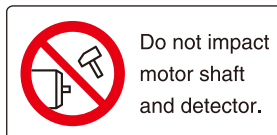

- Be careful not to make any mistakes in the combinations when connecting a motor and a driver. Wiring in the wrong combination may cause unexpected movement. This may result in injury or damage to equipment.

- When installing and wiring, take measures against EMC. Without effective measures to suppress Electromagnetic Interference (EMI) caused by the product or driver to the surrounding control system equipment and Electromagnetic Susceptibility (EMS) generated by the product or driver, the function of your equipment may be seriously affected. Verify EMC compliance with the completed equipment. This may result in injury or damage to equipment.
- The status of the actuating controls shall be clearly indicated, e.g. power on, fault detected, automatic operation. If an indicator light is used, it shall be suitable for its installed location and its color shall meet the requirement of IEC 60204-1.
- Be careful not to get your fingers caught in the stoppers that limit the movement of the L-axis (M2: lower arm) and U-axis (M3: upper arm) of the product. This may result in injury. The label shown in the figure is affixed on the stopper part.



Preparation

Checking the product

Verify that the items listed below are included. Report any missing or damaged items to the Oriental Motor sales office from which you purchased the product.

- Robot 1 unit
- Positioning pin for origin setting 1 piece
- Unpacking procedure 1 copy

How to identify the product model

Verify the model name of the purchased product against the model shown on the nameplate of the product.

OVR **4** **068** **K** **5** - **V**
 1 2 3 4 5

1	Number of axes	4: 4 axes
2	Reach	048: 480 mm (18.90 in.) 068: 680 mm (26.77 in.) 088: 880 mm (34.65 in.)
3	Power supply specification	K: 24 VDC
4	Transportable mass	5: 5 kg (11 lb.)
5	Robot type	V: Articulated

Products that can be combined

Series	Type	Model
AZ Series	Built-in controller type	AZD-KD
AZ Series	mini Driver RS-485 communication type	AZD-KR2D

Information about nameplate

The figure shows an example.

Tip

The position describing the information may vary depending on the product.

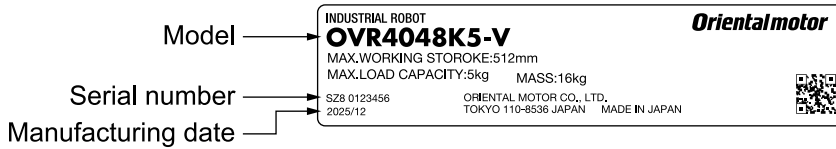

Names of parts

The product consists of four axes: S-axis (M1: rotation), L-axis (M2: lower arm), U-axis (M3: upper arm), and R-axis (M4: wrist rotation).

All motors are of the AZ Series equipped with a battery-free absolute encoder (ABZO sensor). The motors that drive the L-axis (M2: lower arm) and U-axis (M3: upper arm) are equipped with a power-off activated type electromagnetic brake.

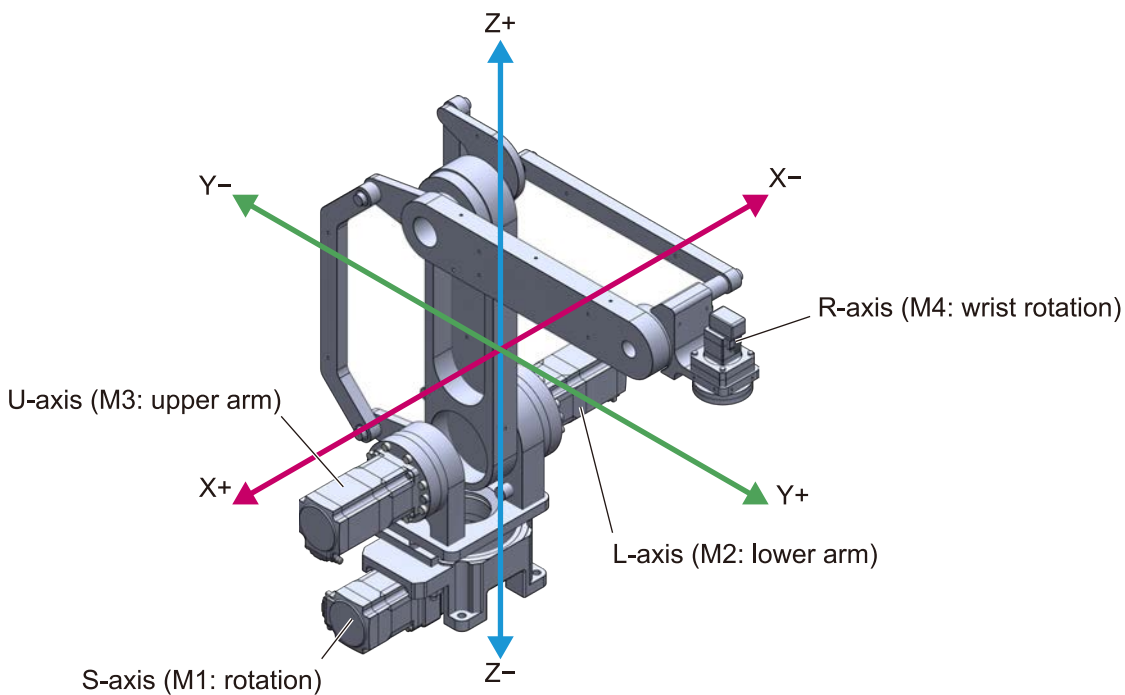

Axis	Drive name	Model
S axis	M1	DGB130R36-AZAKHL*
L axis	M2	AZM66MKH-CSG25-100
U axis	M3	AZM66MKH-CSG20-100
R axis	M4	AZM24AK-CSF8-50

* Contact your nearest Oriental Motor sales office to purchase the product.

Rotation limit mechanical stopper

This product is equipped with mechanical stoppers that limit the movable range.

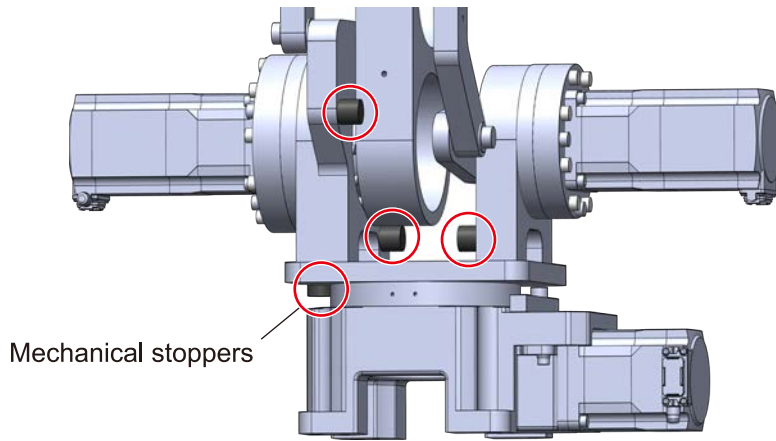

Note

The rotation limit mechanical stoppers are not intended to protect the axis (axes) from falling. Check to ensure safety to use.

Installation of robot

Installation location

The product described in this manual is designed and manufactured to be incorporated into general industrial equipment. Install it in a well-ventilated location that provides easy access for inspection.

The location must also satisfy the following conditions:

- Inside an enclosure installed indoors (provide ventilation holes)
- Operating ambient temperature: 0 to +40 °C [+32 to 104 °F] (non-freezing)
- Operating ambient humidity: 85 % or less (non-condensing)
- Area free of explosive atmosphere, toxic gas (such as sulfuric gas), or liquid
- Area not exposed to direct sun
- Area free of excessive amount of dust, iron particles, or the like
- Area not subject to splashing water (rain, water droplets), oil (oil droplets), or other liquids
- Area free of excessive salt
- Area not subject to continuous vibration or excessive shocks
- Area free of excessive electromagnetic noise (from welders, power equipment, etc.)
- Area free of radioactive materials, magnetic fields, or vacuum
- Up to 1,000 m (3,300 ft.) above sea level

Unpacking method

Note

- Wear protective equipment (helmet, safety shoes, gloves) when working.
- Since the motor is very heavy, make sure that two or more people work together to perform the necessary tasks when transporting or installing it.

1. Place the package on a horizontal, flat surface to unpack.
The product is not in a fixed state in the package. Be careful when handling the product as it may tilt.
2. Hold the gear sections of the L-axis (M2: lower arm) and U-axis (M3: upper arm) with both hands and take out the product.
When removing, be sure to use both hands to hold the specified positions. Improper holding, such as holding the product with one hand or in a position other than that specified, may cause the axis to move in an unexpected direction, resulting in a fall or injury.



3. Place the product in the installation place and remove the packing materials.

Installation method

Note

- Ensure that there is sufficient work space at the installation site so that teaching and maintenance/inspection can be performed safely.
- Do not loosen or remove any screws on the product. This may result in reduced positioning accuracy or damage to the product.
- Work in a stable condition so that the product does not tilt.
- Install the product on a metal surface of sufficient strength to prevent vibration or twisting of an enclosure in which the product is installed.

This section uses OVR4048 as an example to explain.

Use four mounting holes of the S-axis (M1: rotation) to secure the product to the mounting plate.

Provide screw holes in the mounting plate.

When positioning the product, use two positioning pin holes.

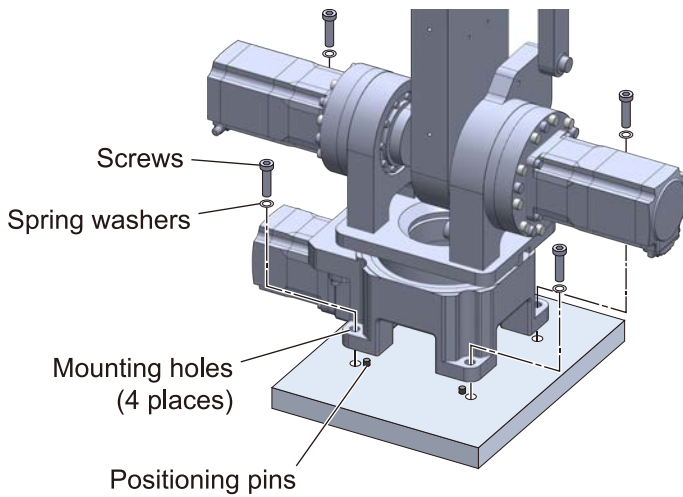

Note

Be sure to install the product from the top of the mounting plate. It cannot be installed from the bottom.

Screws, spring washers, positioning pins are to be provided by the customer. The values of the tightening torque are recommended. Tighten the screws to an appropriate torque according to the design conditions of the mounting plate.

Mounting plate	Thickness: 10 mm (0.39 in.) or more Material: Steel
Mounting hole	Hole diameter: $\varnothing 9$ mm ($\varnothing 0.35$ in.) Nominal designation of thread: M8 Tightening torque: 13 N·m (115 lb-in)
Positioning pin hole	Pin hole diameter: $\varnothing 5_0^{+0.012}$ mm ($\varnothing 0.1969_0^{+0.0005}$ in.) Pin hole depth: 5 mm (0.20 in.), blind hole

Figure viewed from the installation surface side

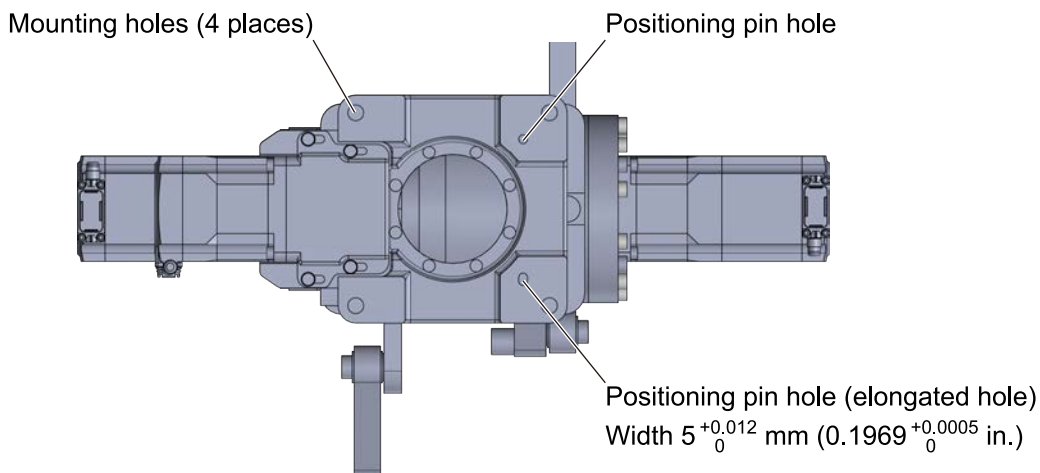

Installation of the end effector

Use four end effector mounting holes of the R-axis (M4: wrist rotation) to install the end effector with screws.

Use three positioning pin holes of the R-axis (M4: wrist rotation) when positioning the end effector. The values of the tightening torque are recommended. Tighten the screws to an appropriate torque according to the design conditions of the end effector.

End effector	Material: Steel or aluminum
Mounting hole	Nominal designation of thread: M5 Tightening torque: 5 N·m (710 oz-in) Effective depth of screw: 6.5 mm (0.26 in.)
Positioning pin hole	Pin hole diameter: $\varphi 5_0^{+0.012}$ mm ($\varphi 0.1969_0^{+0.0005}$ in.) Pin hole depth: 6.5 mm (0.26 in.)

Positioning pin holes (3 places)

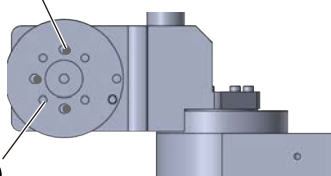

End effector mounting holes (4 places)

ISO 9409-1-31.5-4-M5 Compliant

Wiring example

- Fix the cable at the positions near the connectors so that the connectors do not move.
- Make sure to wire the cable providing a looseness so that no stress is applied to it.
- Maintain 10 m (32.8 ft.) or less for the total wiring distance of the cable.

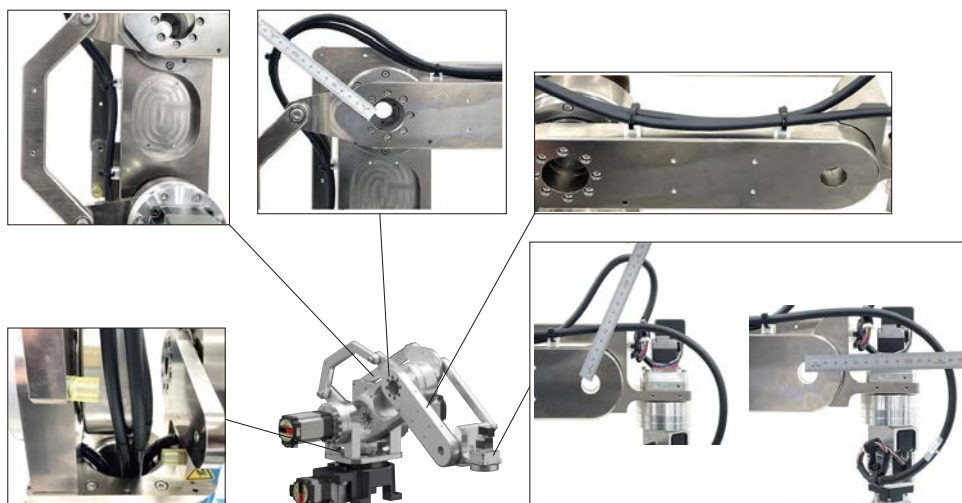

Connection of the connector type motor

The motors for M1 to M3 are those that the cable connection method is the connector type. Connect according to the following method.

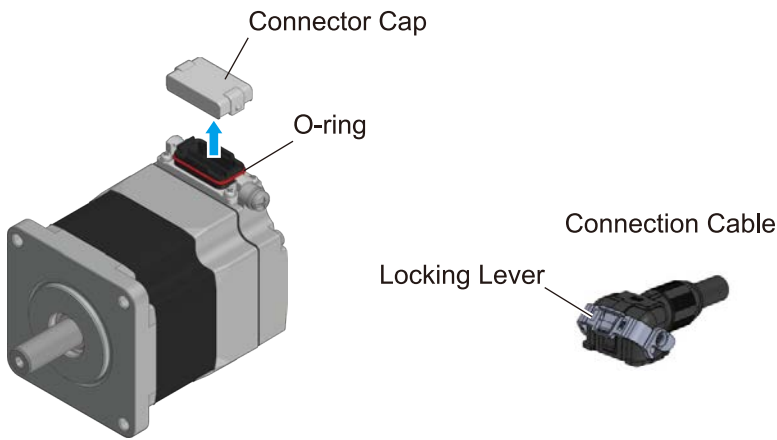

1. Remove the connector cap.

Note

Do not damage the O-ring of the connector when removing the connector cap.

2. Check the position of the connector terminals and connect the connector of the connection cable.
The figure shows an example where the cable outlet direction is opposite to the output shaft direction.

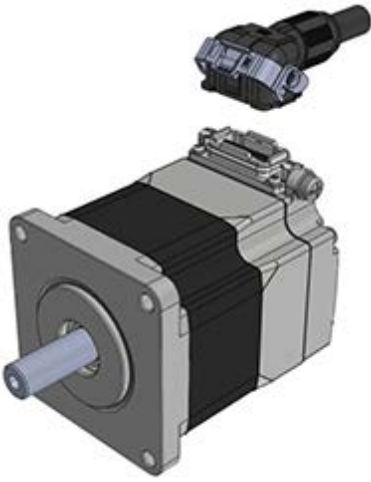

Note

If the locking lever is in a state of being turned up to the 90-degree position or down to the 0-degree position, parts around the locking lever and the connector are in contact with each other, and the connectors cannot be connected.

Locking lever is in 90-degree position



Locking lever is in 0-degree position



3. Turn the locking lever down to the 0-degree position to fix the connector.

Handling of locking lever

- Do not apply excessive force to the locking lever. If the locking lever is damaged, the connector may not be fixed securely.
- After connecting the connector, turn the locking lever down securely to the 0-degree position to fix the connector.

Warning

Be sure to turn down the locking lever. If the connector is not fixed, the cable may come off, resulting in fire, electric shock, or damage to equipment.

Removing the cable

Turn up the locking lever and pull out the connector.

Tip

Turning up the locking lever to the 90-degree position simultaneously disconnects the connector.

Setup

Setup method

Set the information of the robot with the MRC Studio programming software.

1. Start the MRC Studio software.
2. Click [Communication port], select a connected controller.
3. Click [Setup] on the start screen.
4. Set the robot type and the mechanism information according to the instructions on the screen.

Note

The version of MRC Studio software to be used for the OVR4088K5-V varies depending on the manufacturing date of the robot. The manufacturing date can be checked on the nameplate of the robot.

- Manufactured before February 2025: MRC Studio software version 4.3.0.0 or earlier.
- Manufactured after March 2025: MRC Studio software version 5.0.0.0 or later

Origin posture at setup

This product provides four positioning pin holes for origin setting. The position where the included positioning pin can be inserted will be the origin of the axis.

Move the axis to a position where the positioning pin for origin setting can be inserted and set the origin of the axis.

Pin Hole Diameter: $\varnothing 4_0^{+0.012}$ mm ($\varnothing 0.1575_0^{+0.0005}$ in.)

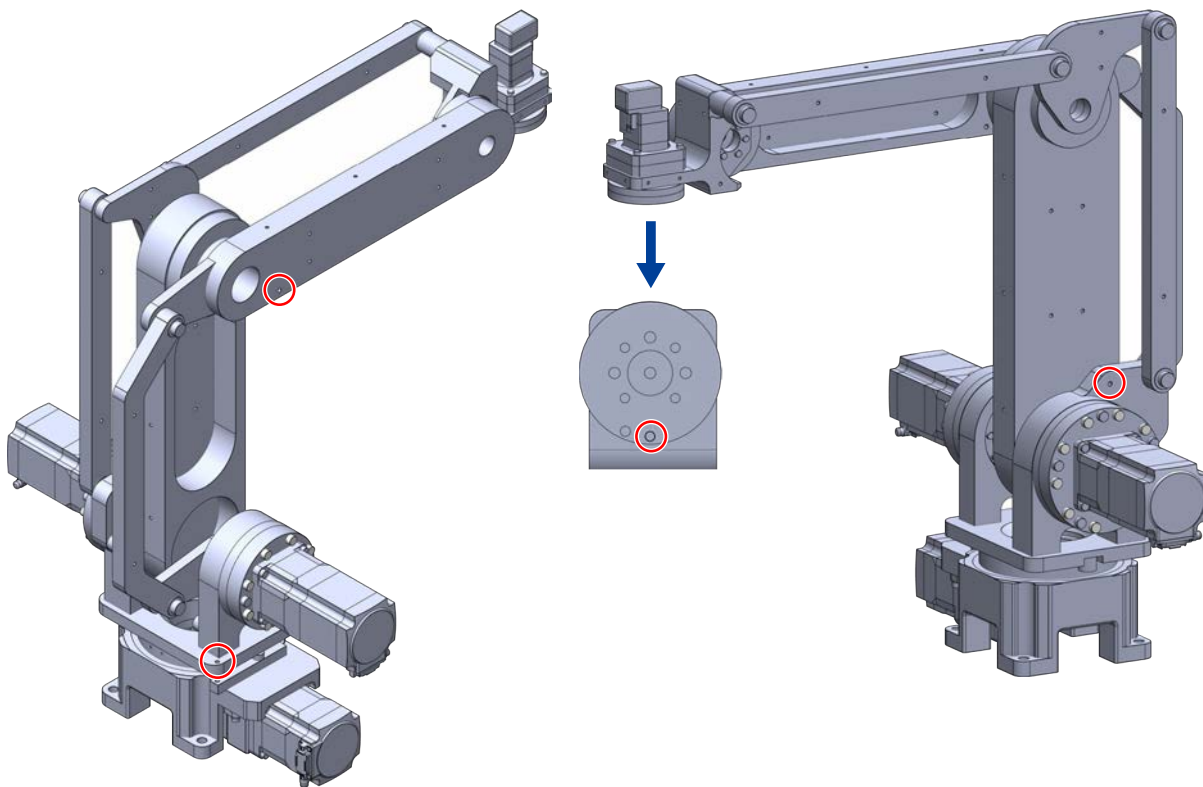

Tip

The origin setting is not required when using the MRC01 robot controller or the MRCU Series integrated robot controller & drivers. Set the origin of the replaced axis only when the motor is replaced.

Maintenance

Assign qualified personnel with sufficient knowledge and experience to perform daily and periodic inspections in accordance with the “Safety Precautions” section.

Be sure to perform these inspections in order to prevent malfunctions in advance and to ensure safety, and check that there are no abnormalities in the product and related equipment before operation. If any abnormality is found, discontinue use immediately and take necessary action, such as repair.

Inspection

Time for inspection

Perform maintenance for each time period shown in the table when operating eight hours per day. Shorten the maintenance cycle depending on the situation when the product is operated continuously day and night or when the operating rate is high.

Time for maintenance	Inspection	Cleaning
When started	○	—
Six months after starting operation	○	—
Every six months thereafter	○	—
As needed	—	○

Inspection items

- Check to see if the position securing the product is loose.
- Check to see if any of the screws securing the end effector are loose.
- Check to see if the cable is damaged, scraped or stressed.
- Check to see if the connection between the motor and driver is loose.
- Before and after the power is turned on, check to see if there is any abnormal noise or vibration coming from the bearing or gears.
- Check to see if the operating point has shifted during return-to-home operation and normal operation (original program operation).

Note

- Enter the inspection results and any special comments on the daily checklist when the inspection is performed.
- Perform the inspection outside of the movable range as much as possible.
- If the product has been repaired as a result of the inspection, keep a record of the contents for at least three years.

Tip

Replace the cable if it is worn out as a result of inspection.

Cleaning

- Wipe off dirt with a soft cloth. If it is very dirty, wipe with a soft cloth with neutral detergent.
- Do not blow with compressed air. Dust may enter through the gap.
- Do not use petroleum-based solvents as they may damage the painted surface.

Warranty

Check on the Oriental Motor Website for the product warranty.

Disposal

Dispose the product correctly in accordance with laws and regulations, or instructions of local governments.

Specifications

Product specifications

Check on the Oriental Motor Website for the product specifications.

General specifications

Degree of protection

IP40 (Excluding the connector part)

Operating environment

Ambient temperature: 0 to +40 °C [+32 to 104 °F] (non-freezing)

Humidity: 85 % or less (non-condensing)

Altitude: Up to 1,000 m (3,300 ft.) above sea level

Atmosphere: No corrosive gas or dust. No exposure to water or oil.

Storage environment and shipping environment

Ambient temperature: -20 to +60 °C [-4 to +140 °F] (non-freezing)

Humidity: 85 % or less (non-condensing)

Altitude: Up to 3,000 m (10,000 ft.) above sea level

Atmosphere: No corrosive gas or dust. No exposure to water or oil.

Accessories

Wrist bending axis mounting bracket

The tip of the arm is always kept horizontal because the 4-axis articulated robot adopts a parallel link mechanism.

When the tip of the arm needs to move in the vertical direction depending on the application of the robot, use the wrist bending axis mounting bracket.

The AZ Series motor and electric gripper can be installed to the wrist bending axis mounting bracket.

Products that can be installed

Model	Electric gripper	Motor
P3B1	EH3-AZAKH	AZM24AK-CSF8-50
P3B2	EH4-AZAKH EH4T-AZAKH	AZM24AK-CSF8-50

Component parts

Motor mounting bracket

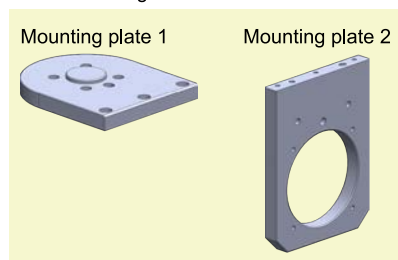

Electric gripper mounting bracket

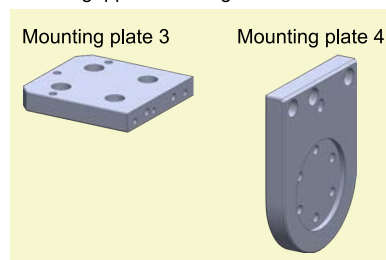

Model	Included	
	Mounting screw	Positioning pin
P3B1	M3×8 mm (0.31 in.) (10 pieces) M3×12 mm (0.47 in.) (6 pieces) M3×25 mm (0.98 in.) (4 pieces) M5×10 mm (0.39 in.) (4 pieces)	φ3×6 mm (φ0.12×0.24 in.) (6 pieces) φ5×10 mm (φ0.20×0.39 in.) (1 piece) φ6×8 mm (φ0.24×0.31 in.) (1 piece)
P3B2	M3×8 mm (0.31 in.) (6 pieces) M3×12 mm (0.47 in.) (6 pieces) M3×25 mm (0.98 in.) (4 pieces) M4×8 mm (0.31 in.) (4 pieces) M5×10 mm (0.39 in.) (4 pieces)	φ3×6 mm (φ0.12×0.24 in.) (6 pieces) φ5×10 mm (φ0.20×0.39 in.) (1 piece) φ10×8 mm (φ0.39×0.31 in.) (1 piece)

Mounting method

1. Use the mounting plates 1 and 2 to assemble the motor mounting bracket.
Tightening torque: 1 N·m (142 oz-in)

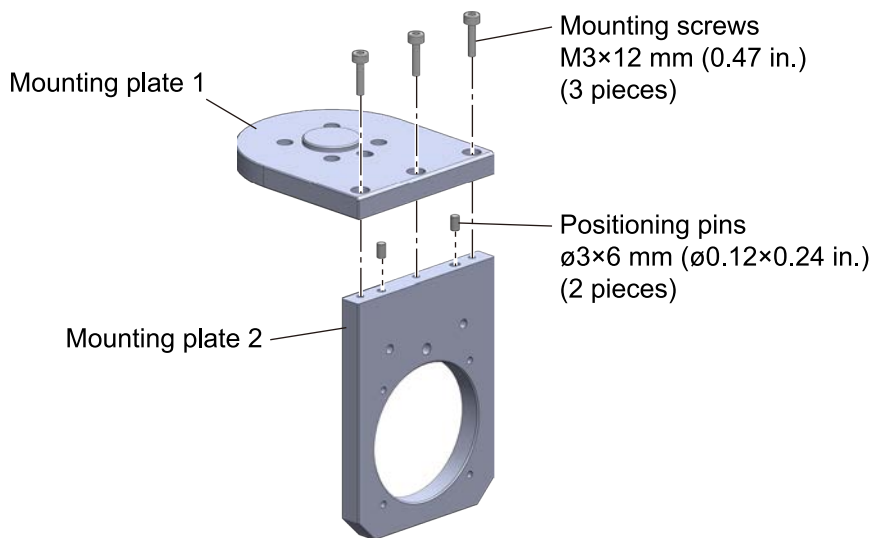

2. Secure the motor mounting bracket to the R-axis (M4: wrist rotation).
Tightening torque: 2.5 N·m (350 oz-in)

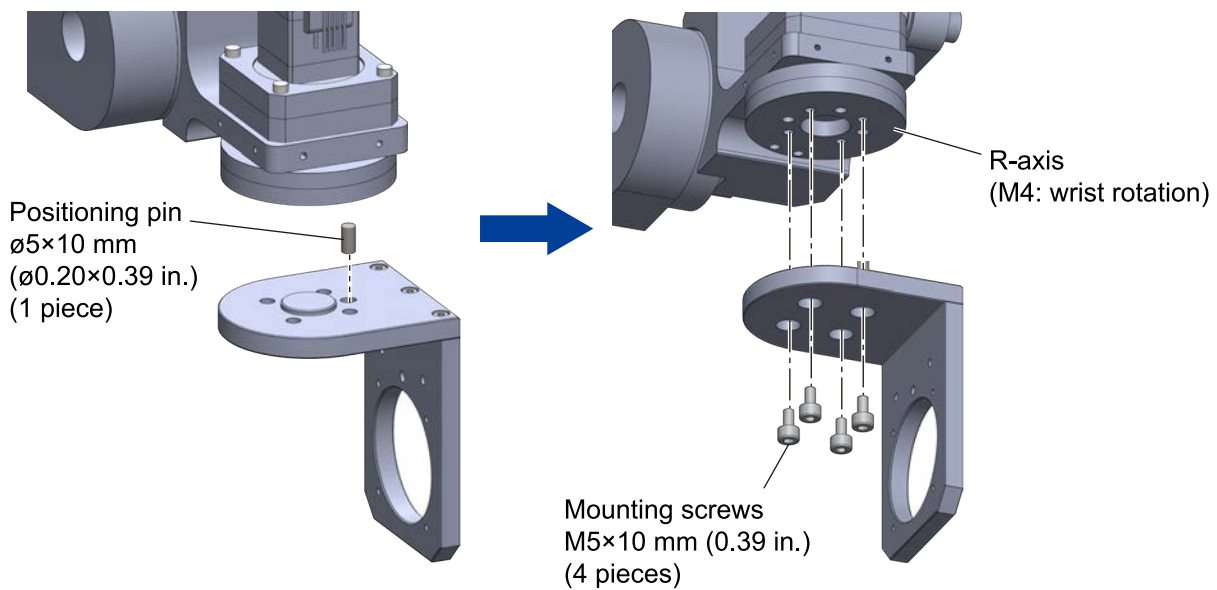

3. Use the pilot of the motor as a guide to secure the motor to the motor mounting bracket.
Tightening torque: 1 N·m (142 oz-in)

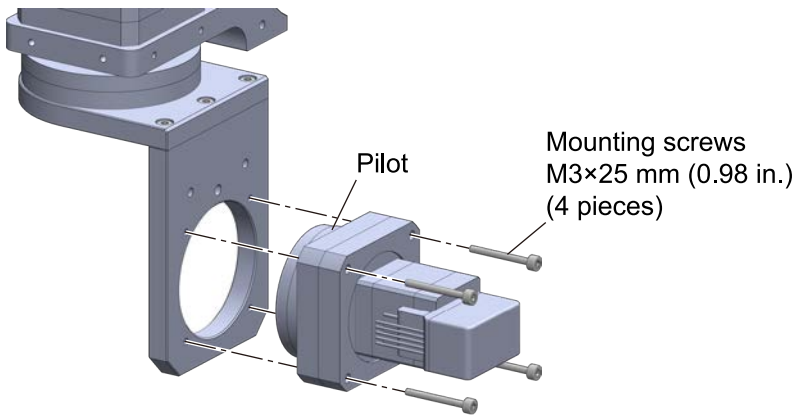

4. Use the mounting plates 3 and 4 to assemble the electric gripper mounting bracket.
Tightening torque: 1 N·m (142 oz-in)

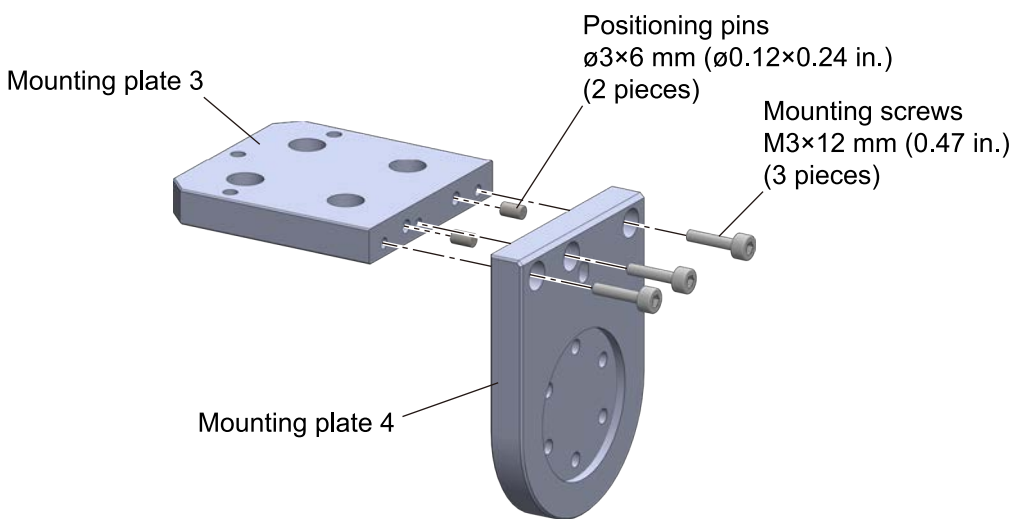

5. Use the pilot of the motor as a guide to secure the motor to the electric gripper mounting bracket.
Mounting screws: M3×8 mm (0.31 in.) (6 pieces)
Tightening torque: 1 N·m (142 oz-in)

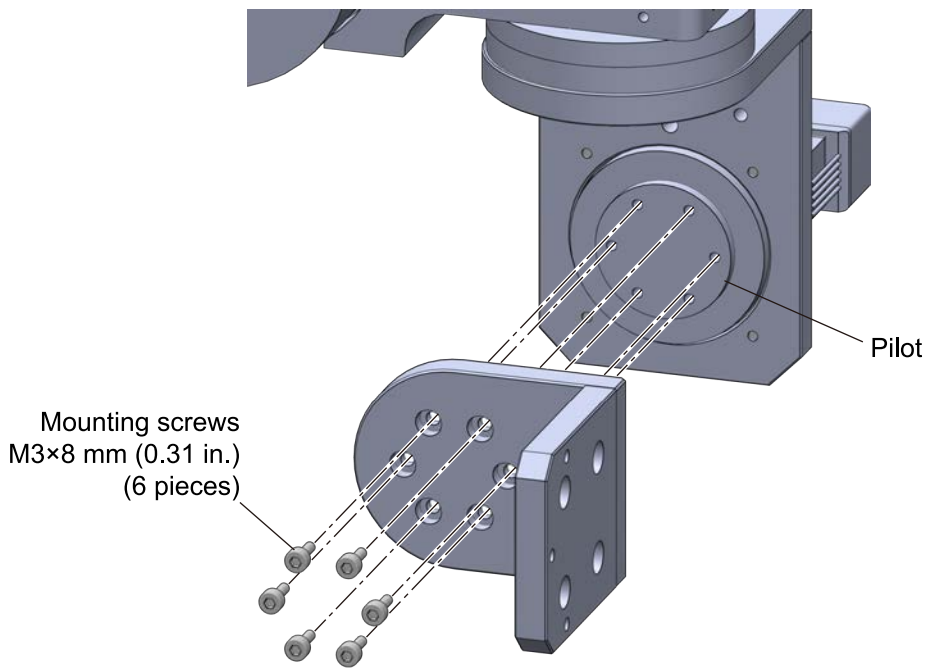

6. Secure the electric gripper to the electric gripper mounting bracket.

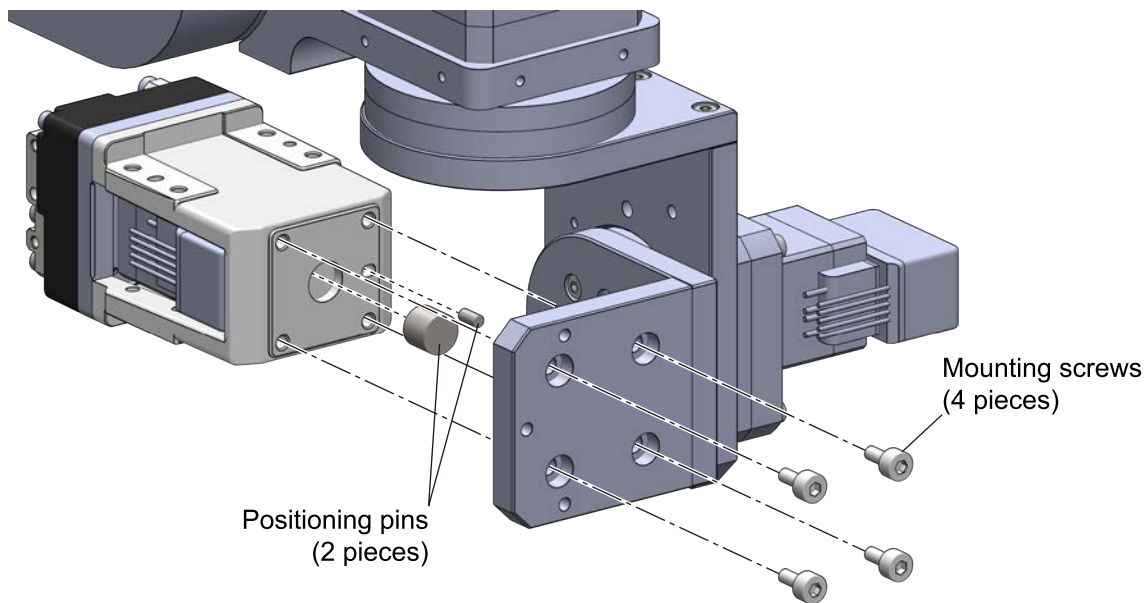

Model of wrist bending axis mounting bracket	P3B1	P3B2
Mounting screw	Screw size: M3×8 mm (0.31 in.) Tightening torque: 1 N·m (142 oz-in)	Screw size: M4×8 mm (0.31 in.) Tightening torque: 2 N·m (280 oz-in)
Positioning pin	φ3×6 mm (φ0.12×0.24 in.) φ6×8 mm (φ0.24×0.31 in.)	φ3×6 mm (φ0.12×0.24 in.) φ10×8 mm (φ0.39×0.31 in.)

Origin posture at setup

The mounting bracket provides a positioning pin hole for origin setting. The position where the included positioning pin can be inserted will be the origin of the axis.

Move the axis to a position where the positioning pin for origin setting can be inserted and set the origin of the axis.

Pin hole diameter: $\varnothing 4_0^{+0.012}$ mm ($\varnothing 0.1575_0^{+0.0005}$ in.)

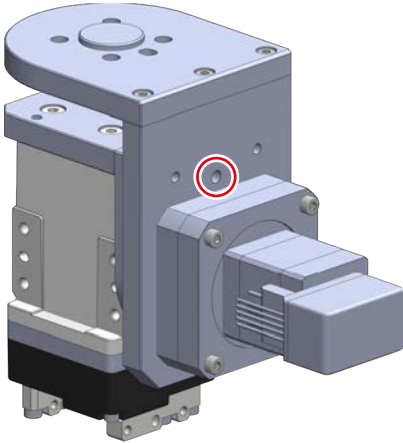

- Unauthorized reproduction or copying of all or part of this manual is prohibited.
- Oriental Motor shall not be liable whatsoever for any problems relating to industrial property rights arising from use of any information, circuit, equipment or device provided or referenced in this manual.
- Characteristics, specifications and dimensions are subject to change without notice.
- While we make every effort to offer accurate information in the manual, we welcome your input. Should you find unclear descriptions, errors or omissions, please contact the nearest office.
- The following is a registered trademark or trademark of Oriental Motor Co., Ltd., in Japan and other countries.

Orientalmotor, ABZO Sensor

- Other product names and company names mentioned in this manual may be registered trademarks or trademarks of their respective companies and are hereby acknowledged. The third-party products mentioned in this manual are recommended products, and references to their names shall not be construed as any form of performance guarantee. Oriental Motor Co., Ltd. is not liable whatsoever for the performance of these third-party products.

© Copyright ORIENTAL MOTOR CO., LTD. 2025

Published in November 2025

• Please contact your nearest Oriental Motor office for further information.

ORIENTAL MOTOR U.S.A. CORP.
Technical Support Tel:800-468-3982
8:30am EST to 5:00pm PST (M-F)

ORIENTAL MOTOR (EUROPA) GmbH
Schiessstraße 44, 40549 Düsseldorf, Germany
Technical Support Tel:00 800/22 55 66 22

ORIENTAL MOTOR (UK) LTD.
Blythe Valley Business Park,
Central Blvd Blythe Valley Park,
Solihull B90 8AG, United Kingdom
Tel:+44-1926-671220

ORIENTAL MOTOR (FRANCE) SARL
Tel:+33-1 47 86 97 50

ORIENTAL MOTOR ITALIA s.r.l.
Tel:+39-02-93906347

ORIENTAL MOTOR ASIA PACIFIC PTE. LTD.
Singapore
Tel:1800-842-0280

ORIENTAL MOTOR (MALAYSIA) SDN. BHD.
Tel:1800-806-161

ORIENTAL MOTOR (THAILAND) CO., LTD.
Tel:1800-888-881

ORIENTAL MOTOR (INDIA) PVT. LTD.
Tel:1800-120-1995 (For English)
1800-121-4149 (For Hindi)

TAIWAN ORIENTAL MOTOR CO., LTD.
Tel:0800-060708

SHANGHAI ORIENTAL MOTOR CO., LTD.
Tel:400-820-6516

JAPAN ORIENTAL MOTOR CO., LTD.
Korea
Tel:080-777-2042

ORIENTAL MOTOR CO., LTD.
4-8-1 Higashiueno, Taito-ku, Tokyo
110-8536 Japan
Tel:+81-3-6744-0361
www.orientalmotor.co.jp/ja