

Development of the CVK Series S Type Driver

Tatsuya Nagamori

Recently, there have been an increasing demand to make equipment both higher-functioning and smaller. The **CVK** series **S** type driver is a product that was developed for customers who use stepper motors with self-built control boards. It has inherited the characteristics of the original **CVK** series of drivers and can be mounted onto boards, contributing to both smaller and higher performance equipment.

The changes from the original **CVK** series of drivers and the background of the development are explained in this article. More specifically, details regarding the circuit configuration adapted from the **CVK** series and the newly added functions (I/O, motor model number setting, SPI^(Note 1) communication) are introduced here.

1. Introduction

Stepper motors are used in a broad variety of equipment, such as for semiconductor manufacturing, measurement, and analysis. In the realm of mass production of equipment that must be small, they are particularly useful with self-built control boards that have a programmable controller and a driver mounted on the same board.

Many self-built control boards employ a driver IC for commercial stepper motors. However, as equipment performance and noise requirements increase, there are more and more cases where commercial driver ICs are inadequate.

The original **CVK** series of drivers (hereinafter “CVD”) can produce higher torque, lower vibration, and lower noise compared to conventional stepper motor drivers, but they were not designed to be mounted onto boards. (See Figure 1.)

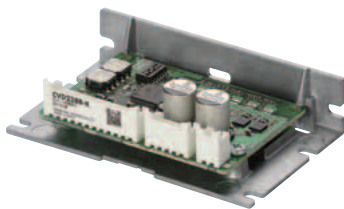

Figure 1: **CVK** Series Driver

The **CVK** series **S** type driver (hereinafter “CVD-S”) was developed to be mounted onto self-built control boards, while maintaining the same characteristics as the CVD series. (See Figure 2.)

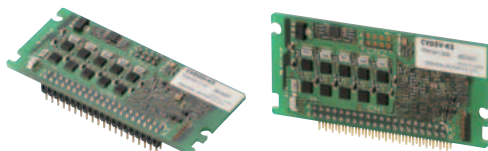

Figure 2: **CVK** Series **S** Type Driver

This article discusses the functions and specifications that were newly added when developing the CVD-S series while considering that it would be mounted on self-built control boards, as well as the technical background to the development.

2. Features

2.1. Overview

CVD drivers achieve less vibration, less noise, higher stop position accuracy, and higher torque characteristics than conventional models. (See Figures 3 and 4.)

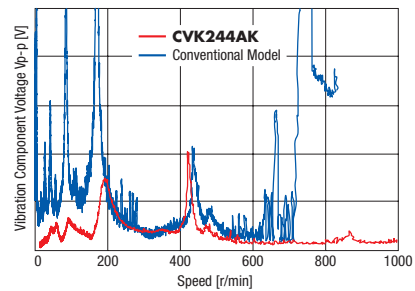

Figure 3: Rotational Vibration Characteristics

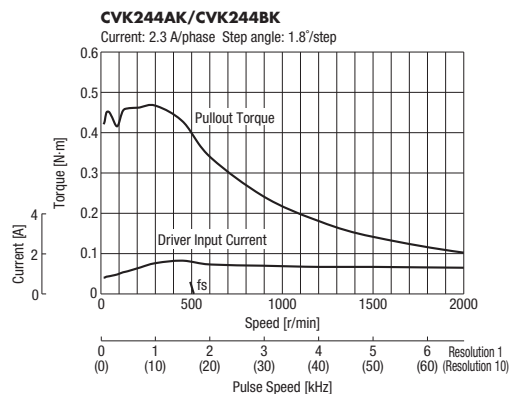

Figure 4: Speed – Torque Characteristics

(Note 1) SPI: Serial Peripheral Interface

CVD-S drivers have the same characteristics as CVD drivers, but are smaller and have more functionality. They are smaller than CVD drivers since they don't contain an I/O photocoupler, electrolytic capacitor, or switches. The connector has also been turned into a pin header, thus saving more space and increasing I/O functionality. (See Figures 5 and 6.)

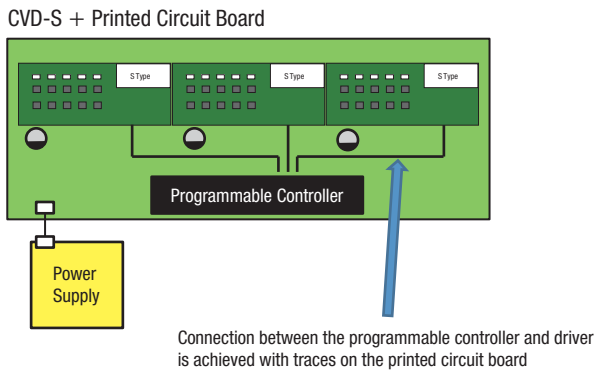
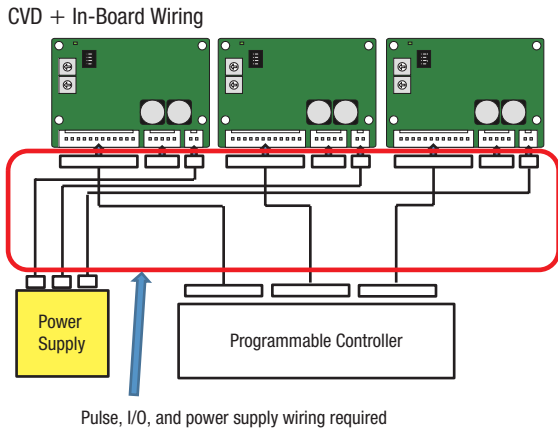

Figure 5: System Configuration Example (3-axis)

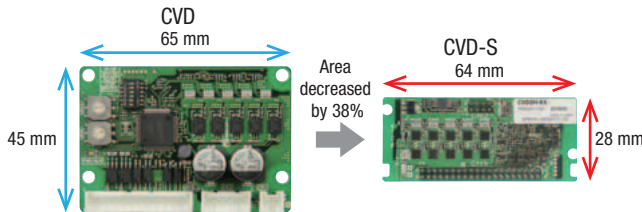

Figure 6: Comparison of Board Sizes

2.2. Product Line

The CVD-S series has a product line of 8 types of drivers, with different numbers of phases, installation methods, and setting methods. (See Table 1.)

Although each of them carries out operation commands with pulses, either I/O (I/O setting type) or I/O + SPI communication (SPI communication setting type) can be selected for the setting and monitoring method.

Table 1: CVD-S Product Line

Product Name	Number of Phases	Installation Method	Setting & Monitoring Method
CVD5H-K	5	Horizontal	I/O
CVD5H-KS			I/O + SPI Communication
CVD5V-K		Vertical	I/O
CVD5V-KS	2	Horizontal	I/O + SPI Communication
CVD2H-K			I/O
CVD2H-KS		Vertical	I/O + SPI Communication
CVD2V-K			I/O
CVD2V-KS			I/O + SPI Communication

With the CVD series, drivers that were optimally adjusted for each motor rating were necessary, but with the CVD-S series, either I/O or SPI communication can be selected so that the optimal settings for each rated motor can be used with a single driver (0.35 to 2.8 A/phase).

The CVD-S series offers two installation directions, depending on the method of installation. The customer can select whether they want to reduce the height or the area of occupancy according to their equipment. (See Table 2.)

Table 2: Comparison of Installation Directions

Grounding Method	Horizontal Configuration Symbol: H (Horizontal)	Vertical Configuration Symbol: V (Vertical)
External View (Arrow: Insertion Direction)		
Mounting Example		
Schematic		

2.3. Circuit Configuration

The main changes in the CVD-S series from the CVD series are as follows.

1) Separation of Control Power Supply and Main Power Supply

The control power supply (5 VDC) and the main power supply (24 VDC) have been separated so that monitoring and settings can still be made with SPI communication when the main power supply is disconnected.

2) External Installation of Electrolytic Capacitor

The CVD-S series does not have an electrolytic capacitor for a power supply. This means that a power supply electrolytic capacitor can be freely arranged on the customer's control board. (Recommendation: Capacity 680 μ F, withstand voltage 50 VDC.)

3) I/O Input of Function Switches

Functions that were set with switches in CVD drivers can now be set with either I/O or SPI communication.

4) Changes to I/O Specifications and Additional Points

CVD-S drivers are directly mounted on the customer's board. This means that the I/O component does not need to be insulated, and there is no longer a photocoupler due to CMOS input and open collector output.

The connector has also been turned into a pin header, thus saving more space. Since this allows for more pins in a small space, functions set with switches can be input with I/O, and more functions can be added. A connection example is shown in Figure 7.

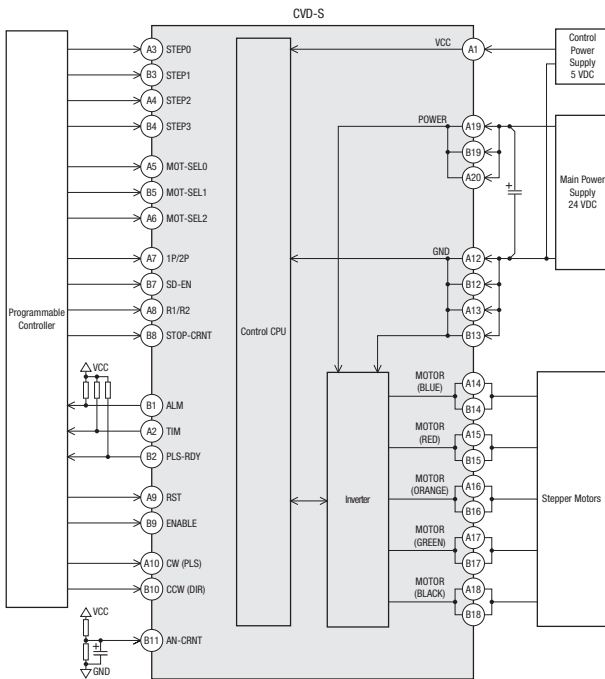

Figure 7: Connection Example (I/O setting type)

3. Heat Measures

3.1. Overview

Heat measures are a major issue for motor drivers. If a lot of heat is generated, the mounting position must be adjusted, a heat sink must be installed, forced cooling is required, and so on. Since there is not much room for heat measures in small devices, any changes made to self-built control boards involve tremendous effort.

Like the CVD series, the CVD-S series offers lower heat generation and increases heat dissipation through the use of a low-loss switching element.

Figure 8 shows the driver's heat distribution during operation (thermographic image). Measurements were made at low-speed operation under extreme driver heat conditions, with a maximum current setting of 2.8 A/phase. Under these measurement conditions, it operated within normal range even with just natural air cooling, with no alarms generated, up to a maximum of 68 °C (ambient temperature+45 °C).

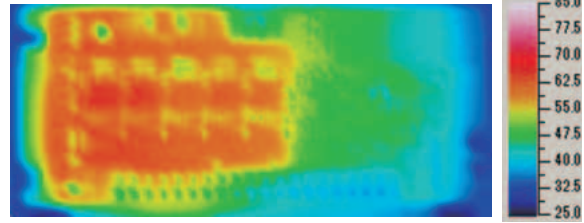

Conditions	
Motor Current	2.8 A/phase (2-phase)
Motor	PKP268D28B
Speed	30 r/min (Continuous operation)
Ambient Temperature	23°C
Cooling	Natural air cooling

Figure 8: Heat Distribution of CVD-S

3.2. Use of a Low-Loss Switching Element

The switching element that controls motor current (Nch MOSFET; hereinafter "FET") is one of the electronic parts in a driver that generates a lot of heat. The main cause of FET heat generation is conduction loss, which increases in proportion to the degree of ON-resistance when current flows to the element. The CVD-S series uses a low-loss FET that decreases the ON-resistance of the FET in conventional products to 1/20 the amount, similar to the CVD series. This reduces the amount of heat generation itself.

3.3. Pattern Design that Takes Heat Dissipation to the Printed Circuit Board into Consideration

It is important to keep the temperature of the FET low in order to ensure its reliability. Previous driver heat measures before the CVD series were to suppress temperature rise to the specified value by dissipating heat generated by the FET to an external aluminum heat sink. In contrast, the CVD and CVD-S series offer a printed circuit board that itself effectively functions as a heat sink, thus eliminating the need for an external aluminum heat sink. This means that the heat resistance of the printed circuit board must be lowered, and the following designs were made with this in mind.

- 1) As Much Copper Foil Area as Possible
- 2) Parallel Connection of Through-Holes

The FET also employs a device with a package that efficiently transmits heat generated inside the element to the printed circuit board. Figure 9 shows a cross-section schematic of a CVD-S printed circuit board, and Figure 10 shows an actual printed circuit board pattern.

Heat generated by the FET is dissipated by transmitting it to the copper foil on the printed circuit board.

By lowering the amount of heat generated and designing a heat dissipation structure in the printed circuit board, the output current can be increased without installing an external aluminum heat sink.

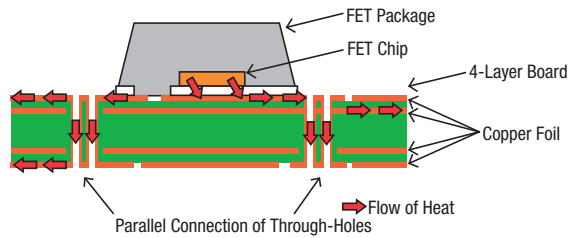

Figure 9: FET and Heat Conduction in the Printed Circuit Board

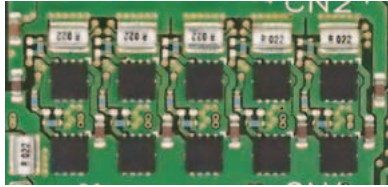

Figure 10: Printed Circuit Board Pattern Around the FET

4. I/O Functions of CVD-S

The CVD-S series offers both an I/O setting type and SPI communication setting type. The changes in the I/O functions from the CVD series are shown in Table 3.

By adding a reset input and a motor model number setting, the circuit is simplified, the customer needs fewer self-built control boards, and fewer models are needed as well.

1) Pulse Ready Output (PLS-RDY)

This is an output signal that notifies the user that the device is operational.

When all of the following conditions are met, PLS-RDY switches to level L.

- The control power supply and main power supply are input.
- No alarm has been generated.
- RST is level H.
- An excitation command is being input.
- The internal state is operational (SPI communication setting type).

2) Resolution Settings (R1/R2, STEP0 to 3)

A total of 32 settings are possible with a combination of five input signals. The values that can be set are the same as in the CVD series.

They can be set via SPI communication in the SPI communication setting type.

3) Motor Model Number Setting Input (MOT-SEL0 to 2)

In the CVD series, high performance is achieved by setting optimal parameters for each motor.

In the CVD-S series, three input signals are used to select from six settings according to the rated current of the motor being used.

Since optimal settings can be used with a single driver for each rated motor, this reduces the number of CVD-S drivers the customer needs.

Motor changes can be adapted to, even if the CVD-S driver has been soldered. Therefore, even if the same self-built control board is being used in equipment with different motors, the CVD-S driver can be installed beforehand. This means that fewer self-built control boards are needed, and fewer models are needed as well.

4) Running Current Setting Input (AN-CRNT)

The running current can be set with analog voltage. Since the value is analog, it can be set more finely than in the CVD series.

The running current can also be set according to the load conditions and operating pattern in order to suppress heat generation.

5) Reset Input (RST)

Resolution and motor model number settings are reflected either when the control power supply is reset or RST is used, rather than being reflected in real time.

Since the settings can be reflected without resetting the entire control power supply of the self-built control board, this simplifies the power supply circuit.

Table 3: Comparison of CVD-S and CVD I/O Functions

Item (Names are standardized for the CVD-S series)	Signal name in CVD-S		Corresponding CVD Signal Name	Change from CVD
	I/O Setting Type	SPI Communication Setting Type		
Pulse Ready Output	PLS-RDY	PLS-RDY	—	Newly added
Alarm Output	ALM	ALM	ALM	Same
Timing Output	TIM	TIM	TIM	Same
Step Angle	—	—	CS	Removed
Excitation ON Input	ENABLE	ENABLE	AWO	Excitation OFF when AWO is ON Excitation ON when ENABLE is at level H
Reset Input	RST	RST	—	Newly added
Smooth Drive Function Setting Input	SD-EN	SD-EN	SD	Same
Command Filter	—	(SPI)*	FIL	I/O setting removed
Running Current Setting Input	AN-CRNT	AN-CRNT	RUN	CVD: 16-step switch input CVD-S: Analog voltage input
Standstill Current Setting Input	STOP-CRNT	STOP-CRNT	STOP	Same
Resolution Table Setting Input	R1/R2	(SPI)*	R1/R2	Same
Resolution Setting Input	STEP0 to 3	(SPI)*	STEP	Same
Pulse Input Mode Setting Input	1P/2P	(SPI)*	1P/2P	Same
Motor Model Number Setting Input	MOT-SEL0 to 2	MOT-SEL0 to 2	—	Newly added

* Can only be set with SPI communication

5. CVD-S SPI Communication Function

5.1. Overview

In CVD-S drivers (SPI communication setting type), various parameters can be set and status monitoring is possible via SPI communication.

Using SPI communication not only decreases the number of connection terminals on the self-built control board, but also allows for more settings and monitoring than with I/O. This increases the functionality and ease of maintenance of the customer's equipment.

SPI communication is a clock synchronization point-to-multipoint serial communication method that is widely used in on-board communication between ICs. (See Figure 11.)

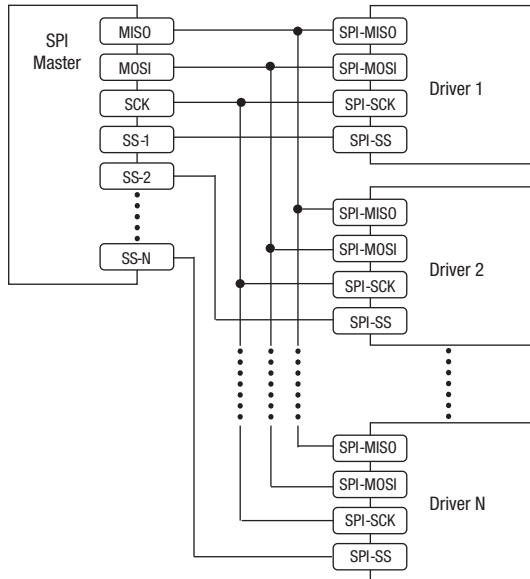

Figure 11: SPI Multi-Axis Bus Connection Diagram

In the CVD-S series (SPI communication setting type), a unique communication protocol is used. Besides settings and monitoring commands, there are also state transition orders. The details that can be communicated differ for each state. (See Table 4.)

When an ACTIVATE command is issued, the driver transitions from the setting state to the operational state, and when a DEACTIVATE command is issued, the driver transitions from the operational state to the setting state.

The settings reflection timing differs depending on whether the set parameters are for real time or when ACTIVATED.

Table 4: Operations in Setting/Operational State

Operation	Setting State	Operational State
Excitation/Operation	×	○
Settings (during transition)*1	○	×
Settings (real-time)*2	○	○
State Transition (Activate)	○	×
State Transition (Deactivate)	×	○
Monitoring	○	○

*1 Reflected when transitioning from setting state to operational state

*2 Reflected in real time

○: Possible ×: Not Possible

5.2. Items that Can be Set

The items that can be set with SPI communication are shown in Table 5.

The items that can be set with the I/O setting type can all be set with SPI communication as well.

Some functions can also be set from I/O, rather than SPI communication. Whether a function is set via either SPI communication or I/O can be set using SPI communication. (Examples: Smooth drive function setting, running current setting)

Unlike the I/O setting type, the SPI communication type allows running current and standstill current to be set individually (standstill current linking setting). This makes heat measures easier to carry out through the current settings.

Table 5: List of SPI Communication Setting Items

Address	Description	bit	Details
02h	Network Input	B15	Alarm LED illumination prohibited
		B14	Power LED illumination prohibited
		B9	Command filter
		B8	Smooth drive function
		B3	Clear communication error
		B1	Excitation switching
04h	Running Current	—	Can be set in the range of 0.1 to 100.0%
06h	Standstill Current	—	Can be set in the range of 0.1 to 50.0 %
0Ah	Driver Settings	B14	Pulse input mode setting
		B13	Smooth drive function setting
		B12	Running current setting
		B11	Standstill current setting
		B10	Motor model number setting
		B9	Excitation switching setting
0Ch	Resolution	B6	Pulse input mode
		B3	Standstill current linking setting
		—	Selected from the resolution table in the range of 200 to 125,000 P/R
0Eh	Motor Model Number Setting	—	The setting is selected according to the model number of the motor being connected

5.3. Items that Can be Monitored

The typical items that can be monitored with SPI communication are shown in Table 6.

Table 6: List of SPI Communication Monitoring Items

Address	Description	Bit	Details
22h	Network Output	B5	Main power supply state
		B4	Overheat
		B3	Excitation state (excited/not excited)
		B2	Pulse ready
		B1	Excitation home (TIM signal)
		B0	Alarm
24h	Alarm	—	—
26h	Driver Temperature	—	—
28h	Main Power Supply Voltage	—	—
2Ah	Analog Input Voltage	—	—
2Ch	Pulse Counter	—	—
40h	Driver Type	—	—
42h	Software	—	—
44h	Software Version	—	—

- Overheat

The overheat bit outputs when the temperature is lower than the temperature at which an overheat alarm is generated.

Since the motor switches to a non-excited state and stops when an overheat alarm is generated, the overheat bit is a measure for lowering the temperature before that happens.

- Pulse counter

The number of pulses recognized by the driver can be obtained. This can be used to check for malfunctions due to noise and as a debugger during development by comparing with the number of pulses from the programmable controller.

- Alarm code

The cause of the alarm can be determined at the host level without checking the number of LED blinks, making it easier to respond to problems.

6. Conclusion

CVD-S drivers were developed for customers who use stepper motors with self-built control boards. Without losing the low-vibration, low-noise, and high-torque characteristics of the CVD series, it can be mounted onto printed circuit boards, contributing to both smaller and higher performance equipment. By using a switching element with little loss as a measure against heat, which is an issue with mounted drivers, and employing a heat dissipation structure in the printed circuit board, heat generation is drastically reduced. The CVD-S series also has additional I/O functions and SPI communication functions.

Oriental Motor will continue to expand on the new technologies that were generated with the development of the CVD-S series, and continue to develop products that meet our customers' demands.

Author



Tatsuya Nagamori

First Product Development Division