

Standard AC Motors

Constant Speed Motors

Electromagnetic Brake Motors

Electromagnetic Brake Motors

- Introduction
- Induction Motors
- Reversible Motors
- Electromagnetic Brake Motors
- V Series
- Clutch & Brake Motors
- Synchronous Motors
- Low-Speed Synchronous Motors
- Watertight, Dust-Resistant Motors
- Torque Motors
- Right-Angle Gearheads
- Linear Heads
- Brake Pack
- Accessories
- Installation

Page

- Features and Types of Electromagnetic Brake Motors..... A-110
- General Specifications ..... A-115
- World **K** Series [6 W~90 W (1/125 HP~1/8 HP)] ... A-116
- BH** Series [200 W (1/4 HP)] ..... A-143

# Features and Types of Electromagnetic Brake Motors

## Features of Electromagnetic Brake Motors

### ● Power Off Activated Type Electromagnetic Brake Equipped

An AC power off activated type electromagnetic brake is equipped to allow the motor to stop instantaneously when the power is cut off, while still holding the load in position.

### ● Ideal for Applications Required Load Holding

This configuration is ideal for vertical applications in which the load must be held.

### ● Extensive Lineup

The World **K** Series and **BH** Series are available.

We have models with an output power range of 6 W (1/125 HP) to 200 W (1/4 HP), so that you can find one that meets your specific application.

### ● Compatible with Gearheads or Linear Heads

Combination with a gearhead allows the motor to reduce to a required speed or generate higher torque.

Combination with a linear head allows the motor to convert rotation to linear motion with great ease.

### ● **RoHS** RoHS-Compliant

The World **K** Series and **BH** Series conform to the RoHS Directive that prohibits the use of six chemical substances including lead and cadmium.

## Types of Electromagnetic Brake Motors

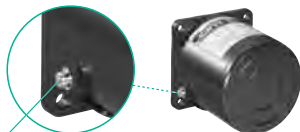
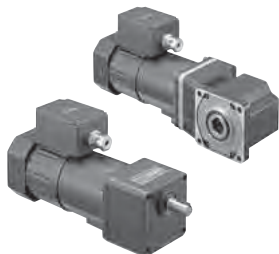
Series	Features, Lineup									
<p><b>World K Series</b></p>  <p><b>UL</b> <b>us</b> <b>CCC</b> <b>CE</b></p>	<ul style="list-style-type: none"> <li>● <b>Conforms to Safety Standards</b> All World <b>K</b> Series models have a built-in overheat protection device and conform to major safety standards.</li> <li>● <b>Applicable Standards</b> UL/CSA Standards Certified under the China Compulsory Certification System (CCC System) CE Marking (Low Voltage Directive)</li> <li>● <b>Motor Overheat Protection Device</b> Thermal protector, Impedance protected</li> <li>● <b>Global Voltage Specifications</b> The World <b>K</b> Series supports the power supply voltages used in major countries. Motors meeting the local voltage standard are readily available in major countries in Europe, Asia and North America.</li> </ul>	<ul style="list-style-type: none"> <li>● <b>The Motor Bearing Life is Twice as Long as a Conventional Type</b> A motor's life is determined by its bearing. We adopted high-performance bearing grease to lubricate this important component. As a result, the bearings of World <b>K</b> Series motors last twice as long as conventional bearings.</li> <li>● <b>Protective Earth Terminal on the Motor</b></li> </ul>  <p>Protective Earth Terminal</p> <ul style="list-style-type: none"> <li>● <b>Lineup</b></li> </ul> <table border="1"> <tr> <td>Frame Size</td> <td>□60 mm (□2.36 in.)~□90 mm (□3.54 in.)</td> </tr> <tr> <td>Output Power</td> <td>6 W~90 W (1/125 HP~1/8 HP)</td> </tr> <tr> <td>Voltage</td> <td>Single-Phase 110/115 VAC Single-Phase 220/230 VAC Three-Phase 200/220/230 VAC</td> </tr> </table>	Frame Size	□60 mm (□2.36 in.)~□90 mm (□3.54 in.)	Output Power	6 W~90 W (1/125 HP~1/8 HP)	Voltage	Single-Phase 110/115 VAC Single-Phase 220/230 VAC Three-Phase 200/220/230 VAC		
Frame Size	□60 mm (□2.36 in.)~□90 mm (□3.54 in.)									
Output Power	6 W~90 W (1/125 HP~1/8 HP)									
Voltage	Single-Phase 110/115 VAC Single-Phase 220/230 VAC Three-Phase 200/220/230 VAC									
<p><b>BH Series</b></p>  <p><b>UL</b> <b>us</b> <b>CE</b></p>	<ul style="list-style-type: none"> <li>● <b>Smallest Frame Size among 200 W (1/4 HP) Motors</b> These motors achieve a high output of 200 W (1/4 HP) with a frame size of 104 mm (4.09 in.).</li> <li>● <b>Hypoid Gear-Employed Right Angle Type is Available.</b></li> <li>● <b>“Combination Type” for Easy Installation</b> With each combination type, the motor and gearhead come pre-assembled for easy installation into your equipment.</li> <li>● <b>Conforms to Safety Standards and Global Voltage Specifications</b></li> </ul>	<ul style="list-style-type: none"> <li>● <b>Lineup</b></li> </ul> <table border="1"> <tr> <td>Frame Size</td> <td>□104 mm (□4.09 in.)</td> </tr> <tr> <td>Output Power</td> <td>200 W (1/4 HP)</td> </tr> <tr> <td>Type</td> <td>Right-Angle, Hollow Shaft Type, Right-Angle, Solid Shaft Type, Parallel Shaft Type, Round Shaft Type</td> </tr> <tr> <td>Voltage</td> <td>Single-Phase 110/115 VAC Single-Phase 220/230 VAC Three-Phase 200/220/230 VAC</td> </tr> </table>	Frame Size	□104 mm (□4.09 in.)	Output Power	200 W (1/4 HP)	Type	Right-Angle, Hollow Shaft Type, Right-Angle, Solid Shaft Type, Parallel Shaft Type, Round Shaft Type	Voltage	Single-Phase 110/115 VAC Single-Phase 220/230 VAC Three-Phase 200/220/230 VAC
Frame Size	□104 mm (□4.09 in.)									
Output Power	200 W (1/4 HP)									
Type	Right-Angle, Hollow Shaft Type, Right-Angle, Solid Shaft Type, Parallel Shaft Type, Round Shaft Type									
Voltage	Single-Phase 110/115 VAC Single-Phase 220/230 VAC Three-Phase 200/220/230 VAC									

## Features of Gearheads and Linear Heads

### ● Gearheads: Easy Speed Reduction and Torque Increase

Combination with a gearhead allows the motor to reduce to a required speed or generate higher torque. Gearheads come in various types including the long life, low noise gearhead and right-angle gearhead.

### ● Linear Heads: Convert Motor Rotation to Linear Motion

Combination with a linear head allows the motor to convert rotation to linear motion with great ease. Linear heads are available with a square sectioned rack.

### ● (RoHS) RoHS-Compliant



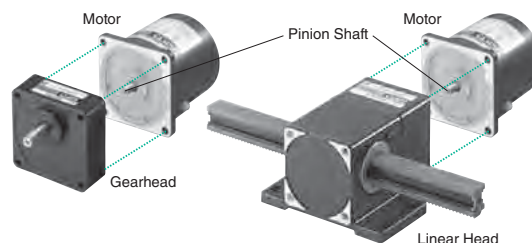

Gearheads and linear heads conform to the RoHS Directive that prohibits the use of six chemical substances including lead and cadmium.

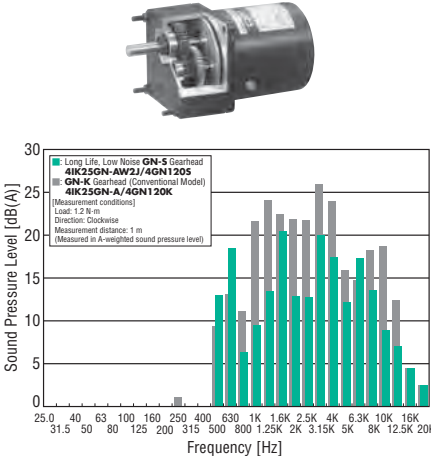

- Combine gearheads and linear heads with a pinion shaft type motor.
- Gearheads and linear heads are sold separately.

**BH** Series comes with the gearhead pre-assembled.

## Types of Gearheads and Linear Heads

Types	Features
<p><b>Long Life, Low Noise GN-S Gearhead</b></p> 	<ul style="list-style-type: none"> <li>● <b>Long Rated Life of 10000 Hours</b> The <b>GN-S</b> gearhead achieves a long rated life of 10000 hours, twice the level of a conventional gearhead, by adopting a large, specially designed bearing and reinforced gears.</li> <li>● <b>Low Noise Design</b> The <b>GN-S</b> gearhead generates less noise thanks to gears with a special shape and surface machining assembled with the use of advanced technology.</li> <li>● <b>Applicable Products</b> 6 W (1/125 HP), 15 W (1/50 HP), 25 W (1/30 HP) or 40 W (1/19 HP) <b>GN</b> pinion motor</li> </ul> 
<p><b>Long Life GE-S Gearhead</b></p> 	<ul style="list-style-type: none"> <li>● <b>Long Rated Life of 10000 Hours</b> The <b>GE-S</b> gearhead achieves a long rated life of 10000 hours, twice the level of a conventional gearhead, by adopting a large, specially designed bearing and reinforced gears.</li> <li>● The <b>GE-S</b> gearhead comes with a tapped hole at the tip of the shaft.</li> <li>● <b>Applicable Products</b> 60 W (1/12 HP) or 90 W (1/8 HP) <b>GE</b> pinion motor</li> </ul>
<p><b>Right-Angle Gearhead</b> → Page A-239</p> 	<ul style="list-style-type: none"> <li>● <b>Ideal Space-Saving Solution</b> The gear shaft is positioned at right angles with the motor shaft, enabling space-saving.</li> <li>● <b>Applicable Products</b> 25 W (1/30 HP), 40 W (1/19 HP), 60 W (1/12 HP) or 90 W (1/8 HP) pinion motor</li> <li>● <b>Hollow Shaft and Solid Shaft Types are Available</b> Select an appropriate type that suits your specific application.</li> <li>● Solid shaft type of <b>GE</b> pinion gearhead comes with a tapped hole at the tip of the shaft.</li> </ul>
<p><b>Rack-and-Pinion Mechanism LS Linear Heads</b> → Page A-259</p> 	<ul style="list-style-type: none"> <li>● <b>Easy to Achieve Linear Motion</b> A rack-and-pinion mechanism is combined with a reduction mechanism, which allows the motor to convert rotation to linear motion with great ease.</li> </ul>

## Product Line of Electromagnetic Brake Motors RoHS

Series	Voltage (VAC)	Motor Frame Size, Output Power						
		□60 mm (□2.36 in.)	□70 mm (□2.76 in.)	□80 mm (□3.15 in.)	□90 mm (□3.54 in.)		□104 mm (□4.09 in.)	
		6 W (1/125 HP)	15 W (1/50 HP)	25 W (1/30 HP)	40 W (1/19 HP)	60 W (1/12 HP)	90 W (1/8 HP)	200 W (1/4 HP)
World <b>K</b> Series	Single-Phase 110/115	●	●	●	●	●	●	
	Single-Phase 220/230	●	●	●	●	●	●	
	Three-Phase 200/220/230	●		●	●	●	●	
<b>BH</b> Series	Single-Phase 110/115							●
	Single-Phase 220/230							●
	Three-Phase 200/220/230							●

## Product Line of Gearheads and Linear Heads RoHS

### ● Gearheads

Gearhead		Applicable Motor			Rated Life (hours)	Low Noise	
Type of Gearhead	Type of Pinion	Series	Output Power	Type of Pinion			
Parallel Shaft	Long Life, Low Noise <b>GN-S</b> Gearhead	<b>GN</b> Type Pinion Shaft	World <b>K</b> Series	6 W~40 W (1/125 HP~1/19 HP)	<b>GN</b> Type Pinion Shaft	10000	●
	<b>GN-K</b> Gearhead	<b>GN</b> Type Pinion Shaft	World <b>K</b> Series	6 W~40 W (1/125 HP~1/19 HP)	<b>GN</b> Type Pinion Shaft	5000	
	Long Life <b>GE-S</b> Gearhead	<b>GE</b> Type Pinion Shaft	World <b>K</b> Series	60 W, 90 W (1/12 HP, 1/8 HP)	<b>GE</b> Type Pinion Shaft	10000	
Right-Angle Shaft	Hollow Shaft Gearhead	<b>GN</b> Type Pinion Shaft	World <b>K</b> Series	25 W, 40 W (1/30 HP, 1/19 HP)	<b>GN</b> Type Pinion Shaft	5000	
		<b>GE</b> Type Pinion Shaft	World <b>K</b> Series	60 W, 90 W (1/12 HP, 1/8 HP)	<b>GE</b> Type Pinion Shaft	5000	
	Solid Shaft Gearhead	<b>GN</b> Type Pinion Shaft	World <b>K</b> Series	25 W, 40 W (1/30 HP, 1/19 HP)	<b>GN</b> Type Pinion Shaft	5000	
		<b>GE</b> Type Pinion Shaft	World <b>K</b> Series	60 W, 90 W (1/12 HP, 1/8 HP)	<b>GE</b> Type Pinion Shaft	5000	

### ● Linear Heads

Type of Linear Head		Applicable Motor		
		Series	Output Power	Type of Pinion
Square Sectioned Rack	<b>LS</b> Linear Head	World <b>K</b> Series	6 W, 25 W (1/125 HP, 1/30 HP)	<b>GN</b> Type Pinion Shaft

## System Configuration

### Gearheads and Linear Heads (Sold separately)

Parallel Shaft Gearheads (→ Page A-111)



Right-Angle Gearheads (→ Page A-239)

Hollow Shaft Type    Solid Shaft Type



Linear Heads (→ Page A-259)

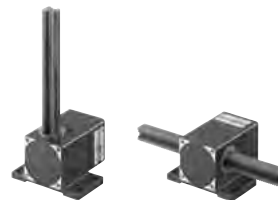

### Electromagnetic Brake Motors

Motor (Pinion Shaft)



Capacitor Cap (Included)



Capacitor (Included)

AC Power Supply (Main power supply)

### Peripheral Equipment (Sold separately)

① Brake Pack SB50W (→ Page A-277)



### Accessories (Sold separately)

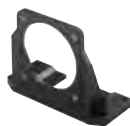

② Mounting Brackets (→ Page A-288)



③ Flexible Couplings (→ Page A-292)



④ CR Circuit for Surge Suppression (→ Page A-302)

No.	Product Name	Overview	Page
①	Brake Pack	Use this brake pack to stop the motor instantaneously, perform bi-directional operation, and more.	A-277
②	Mounting Brackets	Dedicated mounting bracket for the motor and gearhead.	A-288
③	Flexible Couplings	Clamp type coupling that connects the motor or gearhead shaft to the driven shaft.	A-292
④	CR Circuit for Surge Suppression	Used to protect relay and switch contacts ( <b>EPCR1201-2</b> ).	A-302

### ● Example of System Configuration

(Sold separately)

(Sold separately)

Electromagnetic Brake Motor (Pinion shaft)	Long Life, Low Noise Gearhead	+	Mounting Bracket	Flexible Coupling
<b>4RK25GN-AW2MU</b>	<b>4GN25SA</b>		<b>SOL4U10</b>	<b>MCL30F06F06</b>

● Both of gearheads and linear heads cannot be combined with round shaft type motors.

● The system configuration shown above is an example. Other combinations are available.

## Product Number Code

### World K Series

# 5 R K 40 GN - AW 2 M U

① ② ③ ④ ⑤ ⑥ ⑦ ⑧ ⑨

①	Motor Frame Size	<b>2:</b> 60 mm (2.36 in.) <b>3:</b> 70 mm (2.76 in.) <b>4:</b> 80 mm (3.15 in.) <b>5:</b> 90 mm (3.54 in.)
②	Motor Type	<b>I:</b> Induction Motor <b>R:</b> Reversible Motor
③	Series	<b>K:</b> K Series
④	Output Power (W)	(Example) <b>40:</b> 40 W (1/19 HP)
⑤	Motor Shaft Type, Type of Pinion	<b>A:</b> Round Shaft <b>GN:</b> GN Type Pinion Shaft <b>GE:</b> GE Type Pinion Shaft
⑥	Power Supply Voltage	<b>AW:</b> Single-Phase 110/115 VAC <b>CW:</b> Single-Phase 220/230 VAC <b>SW:</b> Three-Phase 200/220/230 VAC
⑦		<b>2:</b> RoHS-Compliant
⑧		<b>M:</b> Power Off Activated Type Electromagnetic Brake
⑨	Included Capacitor	<b>U:</b> For Single-Phase 110/115 VAC <b>E:</b> For Single-Phase 220/230 VAC Blank: Three-Phase Type

● The **U** and **E** at the end of the model name indicate that the unit includes a capacitor. These letters are not listed on the motor nameplate.

When the motor is approved under various safety standards, the model name on the nameplate is the approved model name. → Page G-11

(Example) Model: **5RK40GN-AW2MU** → Motor nameplate and product approved under various safety standards: **5RK40GN-AW2M**

### Gearhead

# 5 GN 50 SA

① ② ③ ④

①	Gearhead Frame Size	<b>2:</b> 60 mm (2.36 in.) <b>3:</b> 70 mm (2.76 in.) <b>4:</b> 80 mm (3.15 in.) <b>5:</b> 90 mm (3.54 in.)
②	Type of Pinion	<b>GN:</b> GN Type Pinion <b>GE:</b> GE Type Pinion
③	Gear Ratio	(Example) <b>50:</b> Gear Ratio of 50:1 <b>10X</b> denotes the decimal gearhead of gear ratio 10:1
④	<b>GN</b> Type Pinion	<b>SA:</b> Long Life, Low Noise <b>GN-S</b> Gearhead, RoHS-Compliant <b>KA:</b> GN-K Gearhead, RoHS-Compliant <b>RH:</b> Right-Angle, Hollow Shaft Gearhead, RoHS-Compliant <b>RAA:</b> Right-Angle, Solid Shaft Gearhead, RoHS-Compliant
	<b>GE</b> Type Pinion	<b>SA:</b> Long Life <b>GE-S</b> Gearhead, RoHS-Compliant <b>RH:</b> Right-Angle, Hollow Shaft Gearhead, RoHS-Compliant <b>RAA:</b> Right-Angle, Solid Shaft Gearhead, RoHS-Compliant

### BH Series

# BH I 6 2 F M T - 100 RH

① ② ③ ④ ⑤ ⑥ ⑦ ⑧ ⑨

①	Series	<b>BH:</b> BH Series
②	Motor Type	<b>I:</b> Induction Motor
③	Motor Frame Size	<b>6:</b> 104 mm (4.09 in.)
④	Output Power (W)	(Example) <b>2:</b> 200 W (1/4 HP)
⑤	Power Supply Voltage	<b>F:</b> Single-Phase 110/115 VAC <b>E:</b> Single-Phase 220/230 VAC <b>S:</b> Three-Phase 200/220/230 VAC
⑥		<b>M:</b> Power Off Activated Type Electromagnetic Brake
⑦		<b>T:</b> Terminal Box Type
⑧	Gear Ratio, Motor Shaft Type	<b>A:</b> Round Shaft Type Number: Gear Ratio of Combination Type
⑨	Type of Gearhead (Combination type only)	<b>RH:</b> Right-Angle, Hollow Shaft Type <b>RA:</b> Right-Angle, Solid Shaft Type Blank: Parallel Shaft Type

## General Specifications

### World K Series

Item	Specifications
Insulation Resistance	100 MΩ or more when 500 VDC megger is applied between the windings and the case after rated motor operation under normal ambient temperature and humidity.
Dielectric Strength	Sufficient to withstand 1.5 kVAC at 50 Hz or 60 Hz applied between the windings and the case for 1 minute after rated motor operation under normal ambient temperature and humidity.
Temperature Rise	Temperature rise of windings are 80°C (144°F) or less measured by the resistance change method after rated operation under normal ambient temperature and humidity with connecting a gearhead or equivalent heat radiation plate*. [Three-phase type: 70°C (126°F) or less]
Insulation Class	Class B [130°C (266°F)]
Overheat Protection	6 W (1/125 HP) type has impedance protection. All others have built-in thermal protector (automatic return type) Open: 130±5°C (266±9°F), Close: 82±15°C (179.6±27°F)
Ambient Temperature	Single-phase 110/115 VAC, Single-phase 220/230 VAC, Three-phase 220/230 VAC: -10~+40°C (+14~+104°F) (non-freezing) Three-phase 200 VAC: -10~+50°C (+14~+122°F) (non-freezing)
Ambient Humidity	85% or less (non-condensing)
Degree of Protection	6 W (1/125 HP), 15 W (1/50 HP), 25 W (1/30 HP), 40 W (1/19 HP) Type: IP20 60 W (1/12 HP), 90 W (1/8 HP) Type: IP40

\* Heat radiation plate (Material: Aluminum)

Motor Type	Size: mm (in.)	Thickness: mm (in.)
6 W (1/125 HP) Type	115×115 (4.53×4.53)	5 (0.20)
15 W (1/50 HP) Type	125×125 (4.92×4.92)	
25 W (1/30 HP) Type	135×135 (5.31×5.31)	
40 W (1/19 HP) Type	165×165 (6.50×6.50)	
60 W (1/12 HP), 90 W (1/8 HP) Type	200×200 (7.87×7.87)	

### BH Series

Item	Specifications
Insulation Resistance	100 MΩ or more when 500 VDC megger is applied between the windings and the case after rated operation under normal ambient temperature and humidity.
Dielectric Strength	Sufficient to withstand 1.5 kVAC at 50 Hz or 60 Hz applied between the windings and the case for 1 minute after rated operation under normal ambient temperature and humidity.
Temperature Rise	Temperature rise of windings are 70°C (126°F) or less measured by the resistance change method after rated operation under normal ambient temperature and humidity with connecting a gearhead or equivalent heat radiation plate*.
Insulation Class	Class B [130°C (266°F)]
Overheat Protection	Built-in thermal protector (automatic return type) Open: 150±5°C (302±9°F), Close: 96±15°C (204.8±27°F)
Ambient Temperature	Single-phase 110/115 VAC, Single-phase 220/230 VAC, Three-phase 220/230 VAC: -10~+40°C (+14~+104°F) (non-freezing) Three-phase 200 VAC: -10~+50°C (+14~+122°F) (non-freezing)
Ambient Humidity	85% or less (non-condensing)
Degree of Protection	IP54 (excluding the installation surface of the round shaft type)

\* Heat radiation plate: 230×230 mm (9.06×9.06 in.), Thickness: 5 mm (0.20 in.) (Material: Aluminum)

## Power Off Activated Type Electromagnetic Brake Motors

## 6 W (1/125 HP)

Frame Size: □60 mm (□2.36 in.)



(Gearhead sold separately)

## Specifications

### ● Motor (RoHS)

● This type of motor does not contain a built-in friction brake mechanism.



Model		Rating	Output Power W HP	Voltage VAC	Frequency Hz	Current A	Starting Torque mN·m oz-in	Rated Torque mN·m oz-in	Rated Speed r/min	Capacitor μF
Pinion Shaft Type	Round Shaft Type									
ZP 2RK6GN-AW2MU	2RK6A-AW2MU	30 minutes	6 1/125	Single-Phase 110	60	0.235	45	41	1450	3.5
				Single-Phase 115		0.242	6.3	5.8		
ZP 2RK6GN-CW2ME	2RK6A-CW2ME	30 minutes	6 1/125	Single-Phase 220	50	0.107	50	49	1150	0.8
					60	0.109	45	41	1450	
				Single-Phase 230	50	0.112	50	49	1200	
					60	0.113	45	41	1450	
ZP 2IK6GN-SW2M	2IK6A-SW2M	Continuous	6 1/125	Three-Phase 200	50	0.081	49	49	1200	-
					60	0.072	41	41	1400	
				Three-Phase 220	60	0.076	41	41	1500	
					Three-Phase 230	60	0.079	5.8		

● The **U** and **E** at the end of the model name indicate that the unit includes a capacitor. These letters are not listed on the motor nameplate. When the motor is approved under various safety standards, the model name on the nameplate is the approved model name. → Page G-11

● Details of safety standards → Page G-2

● Details of RoHS Directive → Page G-38

ZP: Impedance protected

### ● Electromagnetic Brake (Power Off Activated Type)

Motor Model	Voltage	Frequency Hz	Current A	Input W	Holding Brake Torque mN·m oz-in
	VAC				
2RK6GN-AW2MU 2RK6A-AW2MU	Single-Phase 110	60	0.03	3	30
	Single-Phase 115				4.2
2RK6GN-CW2ME 2RK6A-CW2ME	Single-Phase 220	50	0.02	3	30 4.2
		60			
	Single-Phase 230	50			
		60			
2IK6GN-SW2M 2IK6A-SW2M	Single-Phase 200	50	0.02	3	30 4.2
	Single-Phase 220	60			
		Single-Phase 230			

## Product Line

### ● Motor (RoHS)

Model	
Pinion Shaft Type	Round Shaft Type
2RK6GN-AW2MU	2RK6A-AW2MU
2RK6GN-CW2ME	2RK6A-CW2ME
2IK6GN-SW2M	2IK6A-SW2M

The following items are included in each product.

Motor, Capacitor\*, Capacitor Cap\*, Operating Manual

\*Only for single-phase motors



● Parallel Shaft Gearhead (Sold separately) **(RoHS)**

Gearhead Type		Gearhead Model	Gear Ratio
Parallel Shaft	Long Life, Low Noise <b>GN-S</b> Gearhead	<b>2GN□SA</b>	<b>3, 3.6, 5, 6, 7.5, 9, 12.5, 15, 18, 25, 30, 36, 50, 60, 75, 90, 100, 120, 150, 180</b>
		<b>2GN10XS</b> (Decimal Gearhead)	

● Enter the gear ratio in the box (□) within the model name.

The following items are included in each product.  
Gearhead, Mounting Screws, Operating Manual

● Following gearheads are also available. For details, please refer to website (<http://www.orientalmotor.com/>) or contact the nearest Oriental Motor sales office.

Gearhead Type		Gearhead Model	Gear Ratio
Parallel Shaft	<b>(RoHS)</b> <b>GN-K</b> Gearhead	<b>2GN□KA</b>	<b>3~180</b>
		<b>2GN10XK</b> (Decimal Gearhead)	

● Enter the gear ratio in the box (□) within the model name.

## ■ Gearmotor – Torque Table

- Gearheads and decimal gearheads are sold separately.
- Enter the gear ratio in the box (□) within the gearhead model name.
- A colored background (□) indicates gear shaft rotation in the same direction as the motor shaft, while the others rotate in the opposite direction.
- The speed is calculated by dividing the motor's synchronous speed (50 Hz: 1500 r/min, 60 Hz: 1800 r/min) by the gear ratio. The actual speed is 2~20% less than the displayed value, depending on the load.
- To reduce the speed beyond the gear ratio in the table, attach a decimal gearhead (gear ratio 10:1) between the gearhead and the motor. In that case, the permissible torque is 3 N·m (26 lb-in).

### ◇ 50 Hz

Unit = Upper values: N-m/Lower values: lb-in

Model Motor/ Gearhead	Speed r/min	500	416	300	250	200	166	120	100	83	60	50	41	30	25	20	16	15	12.5	10	8.3
	Gear Ratio	<b>3</b>	<b>3.6</b>	<b>5</b>	<b>6</b>	<b>7.5</b>	<b>9</b>	<b>12.5</b>	<b>15</b>	<b>18</b>	<b>25</b>	<b>30</b>	<b>36</b>	<b>50</b>	<b>60</b>	<b>75</b>	<b>90</b>	<b>100</b>	<b>120</b>	<b>150</b>	<b>180</b>
<b>2RK6GN-CW2ME</b> <b>2IK6GN-SW2M</b>	<b>2GN□SA</b>	0.12 1.06	0.14 1.23	0.20 1.77	0.24 2.1	0.30 2.6	0.36 3.1	0.50 4.4	0.60 5.3	0.71 6.2	0.89 7.8	1.1 9.7	1.3 11.5	1.6 14.1	1.9 16.8	2.4 21	2.9 25	3 26	3 26	3 26	3 26

### ◇ 60 Hz

Unit = Upper values: N-m/Lower values: lb-in

Model Motor/ Gearhead	Speed r/min	600	500	360	300	240	200	144	120	100	72	60	50	36	30	24	20	18	15	12	10
	Gear Ratio	<b>3</b>	<b>3.6</b>	<b>5</b>	<b>6</b>	<b>7.5</b>	<b>9</b>	<b>12.5</b>	<b>15</b>	<b>18</b>	<b>25</b>	<b>30</b>	<b>36</b>	<b>50</b>	<b>60</b>	<b>75</b>	<b>90</b>	<b>100</b>	<b>120</b>	<b>150</b>	<b>180</b>
<b>2RK6GN-AW2MU</b> <b>2RK6GN-CW2ME</b> <b>2IK6GN-SW2M</b>	<b>2GN□SA</b>	0.10 0.88	0.12 1.06	0.17 1.50	0.20 1.77	0.25 2.2	0.30 2.6	0.42 3.7	0.50 4.4	0.60 5.3	0.75 6.6	0.90 7.9	1.1 9.7	1.4 12.3	1.6 14.1	2.0 17.7	2.4 21	2.7 23	3 26	3 26	3 26

## ■ Permissible Overhung Load and Permissible Thrust Load

Motor (Round shaft type) → Page A-16

Gearhead → Page A-16

## ■ Permissible Load Inertia J of Gearhead

→ Page A-17

## Starting and Braking Characteristics (Reference Values)

### Single-Phase Motor

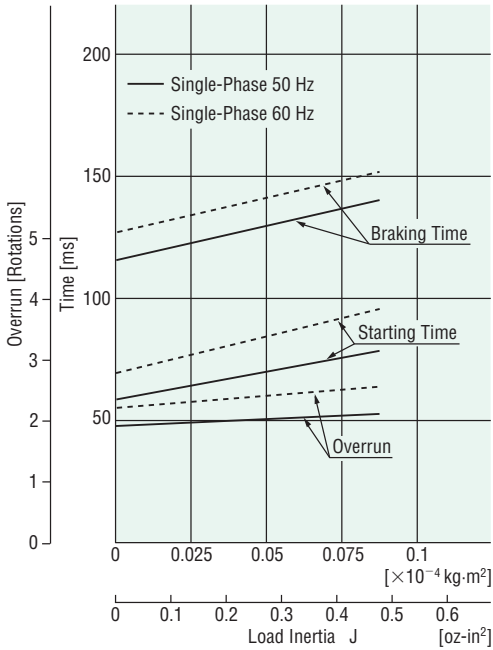

### Three-Phase Motor

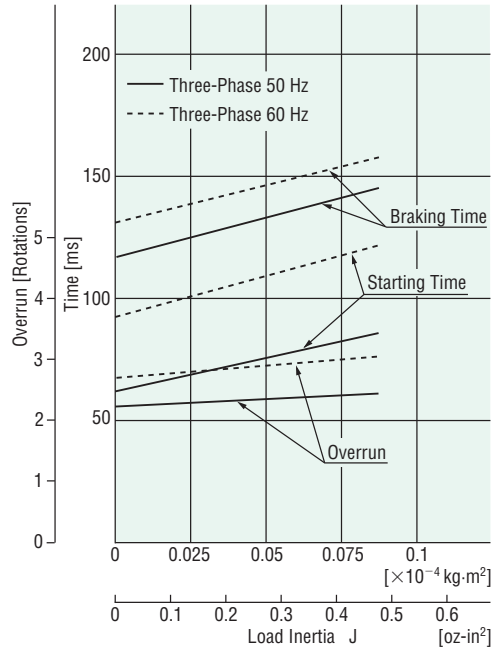

## Dimensions Unit = mm (in.)

● Mounting screws are included with gearheads. Dimensions for mounting screws → Page A-310

### ◇ Motor/Gearhead

Mass: Motor 0.9 kg (1.98 lb.)  
Gearhead 0.4 kg (0.88 lb.)

Motor Model	Gearhead Model	Gear Ratio	L	DXF
2RK6GN-AW2MU 2RK6GN-CW2ME 2IK6GN-SW2M	2GN□SA	3~18	30 (1.18)	A462AU
		25~180	40 (1.57)	A462BU

● Enter the gear ratio in the box (□) within the model name.

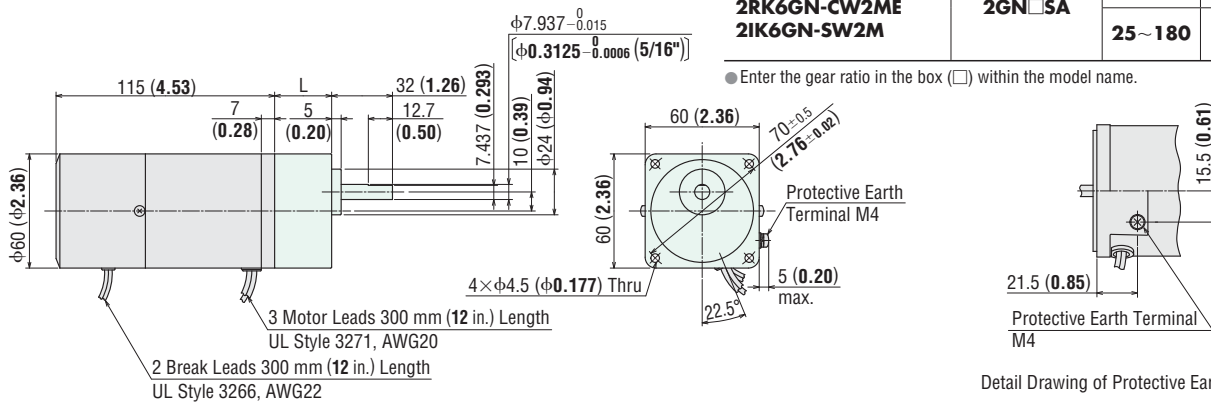

### ◇ Shaft Section of Round Shaft Type

The motor's dimensions (excluding the shaft section) are the same as those of the pinion shaft types.

Mass: 0.9 kg (1.98 lb.)

DXF A463

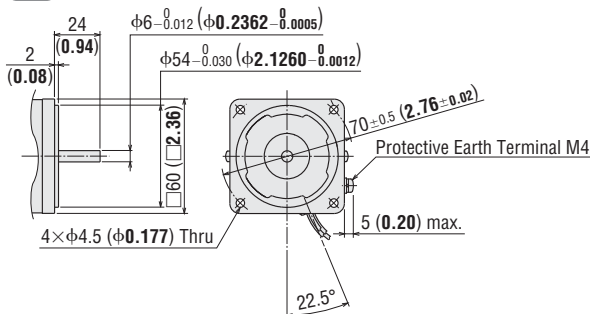

### ◇ Decimal Gearhead

Can be connected to **GN** pinion shaft type.

2GN10XS

Mass: 0.2 kg (0.44 lb.)

DXF A003

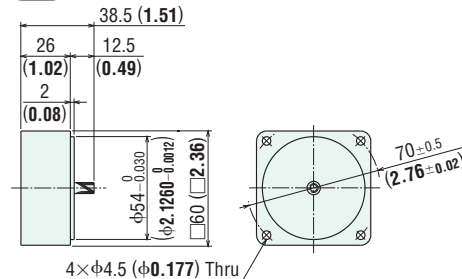

◇ Capacitor  
(Included with single-phase motors)

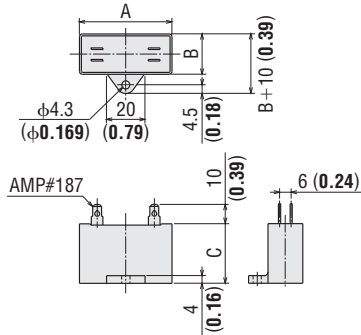

◇ Capacitor Dimensions Unit = mm (in.)

Model		Capacitor Model	A	B	C	Mass g (oz.)	Capacitor Cap
Pinion Shaft Type	Round Shaft Type						
<b>2RK6GN-AW2MU</b>	<b>2RK6A-AW2MU</b>	CH35FAUL2	31 (1.22)	17 (0.67)	27 (1.06)	22 (0.78)	Included
<b>2RK6GN-CW2ME</b>	<b>2RK6A-CW2ME</b>	CH08BFAUL	31 (1.22)	17 (0.67)	27 (1.06)	23 (0.81)	

■ Connection Diagrams

- The direction of motor rotation is as viewed from the shaft end of the motor. CW represents the clockwise direction, while CCW represents the counterclockwise direction.
- Connection diagrams are also valid for the equivalent round shaft type.

Single-Phase Motor	<p><b>2RK6GN-AW2MU</b> <b>2RK6GN-CW2ME</b></p>	<p>SW1 operates both motor and electromagnetic brake action. The electromagnetic brake will be released and the motor will rotate when SW1 is switched simultaneously to ON. When SW1 is switched simultaneously to OFF, the motor stops immediately with the electromagnetic brake and holds the load.</p> <p>If you wish to release the brake while the motor is stopped, apply voltage between the two brake lead wires (orange).</p> <p>Rotation Direction To rotate the motor in a clockwise (CW) direction, turn SW2 to CW. To rotate the motor in a counterclockwise (CCW) direction, turn SW2 to CCW.</p>														
		<table border="1"> <thead> <tr> <th rowspan="2">Switch No.</th> <th colspan="2">Specifications</th> <th rowspan="2">Note</th> </tr> <tr> <th>Single-Phase 110/115 VAC Input</th> <th>Single-Phase 220/230 VAC Input</th> </tr> </thead> <tbody> <tr> <td>SW1</td> <td>125 VAC 3 A minimum (Inductive Load)</td> <td>250 VAC 1.5 A minimum (Inductive Load)</td> <td>Switched Simultaneously</td> </tr> <tr> <td>SW2</td> <td></td> <td></td> <td>—</td> </tr> </tbody> </table>	Switch No.	Specifications		Note	Single-Phase 110/115 VAC Input	Single-Phase 220/230 VAC Input	SW1	125 VAC 3 A minimum (Inductive Load)	250 VAC 1.5 A minimum (Inductive Load)	Switched Simultaneously	SW2			—
Switch No.	Specifications			Note												
	Single-Phase 110/115 VAC Input	Single-Phase 220/230 VAC Input														
SW1	125 VAC 3 A minimum (Inductive Load)	250 VAC 1.5 A minimum (Inductive Load)	Switched Simultaneously													
SW2			—													
Three-Phase Motor	<p><b>2IK6GN-SW2M</b></p>	<p>SW1 operates both motor and electromagnetic brake action. The electromagnetic brake will be released and the motor will rotate when SW1 is switched simultaneously to ON. When SW1 is switched simultaneously to OFF, the motor stops immediately with the electromagnetic brake and holds the load.</p> <p>If you wish to release the brake while the motor is stopped, apply voltage between the two brake lead wires (orange).</p> <p>Rotation Direction To change the rotation direction, change any two connections between L1(R), L2(S) and L3(T).</p>														
		<table border="1"> <thead> <tr> <th>Switch No.</th> <th>Specifications</th> <th>Note</th> </tr> </thead> <tbody> <tr> <td>SW1</td> <td>250 VAC 1.5 A minimum (Inductive Load)</td> <td>Switched Simultaneously</td> </tr> </tbody> </table>	Switch No.	Specifications	Note	SW1	250 VAC 1.5 A minimum (Inductive Load)	Switched Simultaneously								
Switch No.	Specifications	Note														
SW1	250 VAC 1.5 A minimum (Inductive Load)	Switched Simultaneously														

PE: Protective Earth

● R<sub>0</sub> and C<sub>0</sub> indicate CR circuit for surge suppression. [R<sub>0</sub> = 5~200 Ω, C<sub>0</sub> = 0.1~0.2 μF, 200 WV (400 WV)]

● EPCR1201-2 (CR circuit) is available as an accessory. → Page A-302

● How to connect a capacitor → Page A-313

Linear Head, Accessories and Peripheral Equipment

Linear Motion  
Linear Heads  
→ Page A-259

Instantaneous Stop  
Brake Pack  
→ Page A-277

Accessories  
→ Page A-287

## Power Off Activated Type Electromagnetic Brake Motors

## 15 W (1/50 HP)

Frame Size: □70 mm (□2.76 in.)



(Gearhead sold separately)

## Specifications

### ● Motor (RoHS)

- This type of motor does not contain a built-in friction brake mechanism.



Model		Rating	Output Power W HP	Voltage VAC	Frequency Hz	Current A	Starting Torque mN·m oz-in	Rated Torque mN·m oz-in	Rated Speed r/min	Capacitor μF
Pinion Shaft Type	Round Shaft Type									
TP 3RK15GN-AW2MU	3RK15A-AW2MU	30 minutes	15 1/50	Single-Phase 110	60	0.42	100 14.2	105 14.9	1450	6.0
				Single-Phase 115		0.41				
TP 3RK15GN-CW2ME	3RK15A-CW2ME	30 minutes	15 1/50	Single-Phase 220	50	0.18	100 14.2	125 17.7	1200	1.5
					60	0.20		105 14.9		
				Single-Phase 230	50	0.19	100 14.2	125 17.7	1200	
					60	0.20		105 14.9		

- The **U** and **E** at the end of the model name indicate that the unit includes a capacitor. These letters are not listed on the motor nameplate. When the motor is approved under various safety standards, the model name on the nameplate is the approved model name. → Page G-11

- Details of safety standards → Page G-2

- Details of RoHS Directive → Page G-38

TP: Contains a built-in thermal protector (automatic return type). If a motor overheats for any reason, the thermal protector is activated and the motor is stopped. (The power supply to the electromagnetic brake is kept and the brake is released.)

When the motor temperature drops, the thermal protector closes and the motor restarts. Be sure to turn the motor power off before inspecting.

### ● Electromagnetic Brake (Power Off Activated Type)

Motor Model	Voltage VAC	Frequency Hz	Current A	Input W	Holding Brake Torque mN·m oz-in	
3RK15GN-AW2MU 3RK15A-AW2MU	Single-Phase 110	60	0.09	7	80	
	Single-Phase 115				11.3	
3RK15GN-CW2ME 3RK15A-CW2ME	Single-Phase 220	50	0.05	7	80	
		60				11.3
	Single-Phase 230	50			60	80
		60				

## Product Line

### ● Motor (RoHS)

Model	
Pinion Shaft Type	Round Shaft Type
3RK15GN-AW2MU	3RK15A-AW2MU
3RK15GN-CW2ME	3RK15A-CW2ME

The following items are included in each product.  
Motor, Capacitor, Capacitor Cap, Operating Manual

### ● Parallel Shaft Gearhead (Sold separately) (RoHS)

Gearhead Type		Gearhead Model	Gear Ratio
Parallel Shaft	Long Life, Low Noise GN-S Gearhead	3GN□SA	3, 3.6, 5, 6, 7.5, 9, 12.5, 15, 18, 25, 30, 36, 50, 60, 75, 90, 100, 120, 150, 180
		3GN10XS (Decimal Gearhead)	

- Enter the gear ratio in the box (□) within the model name.

The following items are included in each product.  
Gearhead, Mounting Screws, Operating Manual

- Following gearheads are also available. For details, please refer to website (<http://www.orientalmotor.com/>) or contact the nearest Oriental Motor sales office.

Gearhead Type		Gearhead Model	Gear Ratio
Parallel Shaft	(RoHS) GN-K Gearhead	3GN□KA	3~180
		3GN10XK (Decimal Gearhead)	

- Enter the gear ratio in the box (□) within the model name.

## Gearmotor – Torque Table

- Gearheads and decimal gearheads are sold separately.
- Enter the gear ratio in the box (□) within the gearhead model name.
- A colored background (□) indicates gear shaft rotation in the same direction as the motor shaft, while the others rotate in the opposite direction.
- The speed is calculated by dividing the motor's synchronous speed (50 Hz: 1500 r/min, 60 Hz: 1800 r/min) by the gear ratio. The actual speed is 2~20% less than the displayed value, depending on the load.
- To reduce the speed beyond the gear ratio in the table, attach a decimal gearhead (gear ratio 10:1) between the gearhead and the motor. In that case, the permissible torque is 5 N·m (44 lb-in).

### ◇ 50 Hz

Unit = Upper values: N-m/Lower values: lb-in

Model	Motor/ Gearhead	Speed r/min	500	416	300	250	200	166	120	100	83	60	50	41	30	25	20	16	15	12.5	10	8.3
		Gear Ratio	3	3.6	5	6	7.5	9	12.5	15	18	25	30	36	50	60	75	90	100	120	150	180
<b>3RK15GN-CW2ME</b>	<b>3GN□SA</b>	0.30	0.36	0.51	0.61	0.76	0.91	1.3	1.5	1.8	2.3	2.7	3.3	4.1	5	5	5	5	5	5	5	5
		2.6	3.1	4.5	5.3	6.7	8.0	11.5	13.2	15.9	20	23	29	36	44	44	44	44	44	44	44	44

### ◇ 60 Hz

Unit = Upper values: N-m/Lower values: lb-in

Model	Motor/ Gearhead	Speed r/min	600	500	360	300	240	200	144	120	100	72	60	50	36	30	24	20	18	15	12	10
		Gear Ratio	3	3.6	5	6	7.5	9	12.5	15	18	25	30	36	50	60	75	90	100	120	150	180
<b>3RK15GN-AW2MU</b> <b>3RK15GN-CW2ME</b>	<b>3GN□SA</b>	0.26	0.31	0.43	0.51	0.64	0.77	1.1	1.3	1.5	1.9	2.3	2.8	3.5	4.2	5	5	5	5	5	5	5
		2.3	2.7	3.8	4.5	5.6	6.8	9.7	11.5	13.2	16.8	20	24	30	37	44	44	44	44	44	44	44

## Permissible Overhung Load and Permissible Thrust Load

Motor (Round shaft type) → Page A-16

Gearhead → Page A-16

## Permissible Load Inertia J of Gearhead

→ Page A-17

## Starting and Braking Characteristics (Reference values)

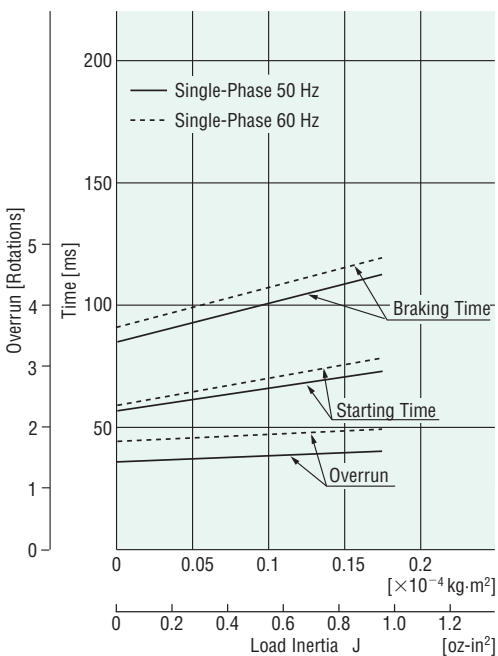

## Dimensions Unit = mm (in.)

● Mounting screws are included with gearheads. Dimensions for mounting screws → Page A-310

### ◇ Motor/Gearhead

Mass: Motor 1.3 kg (2.9 lb.)  
Gearhead 0.55 kg (1.21 lb.)

Motor Model	Gearhead Model	Gear Ratio	L	DXF
<b>3RK15GN-AW2MU</b> <b>3RK15GN-CW2ME</b>	<b>3GN□SA</b>	<b>3~18</b>	32 (1.26)	A464AU
		<b>25~180</b>	42 (1.65)	A464BU

● Enter the gear ratio in the box (□) within the model name.

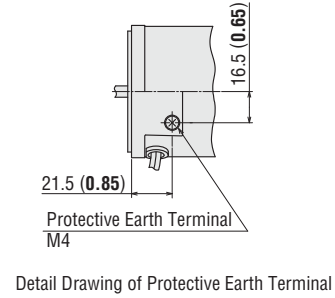
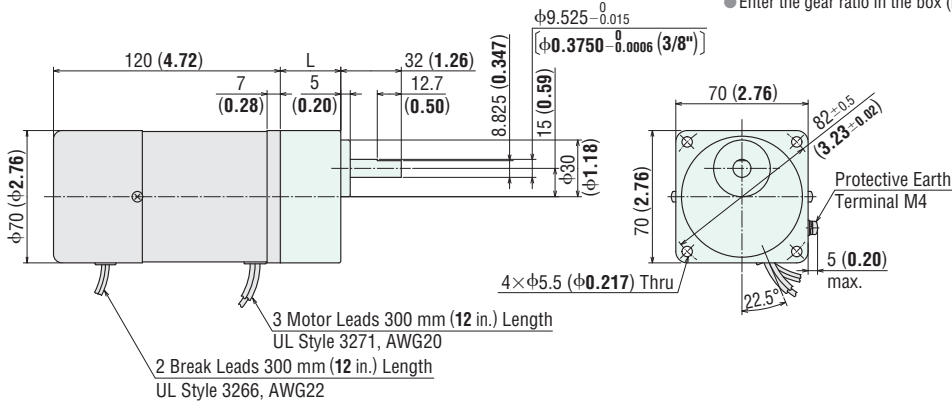

### ◇ Shaft Section of Round Shaft Type

The motor's dimensions (excluding the shaft section) are the same as those of the pinion shaft types.

Mass: 1.3 kg (2.9 lb.)

**DXF** A465

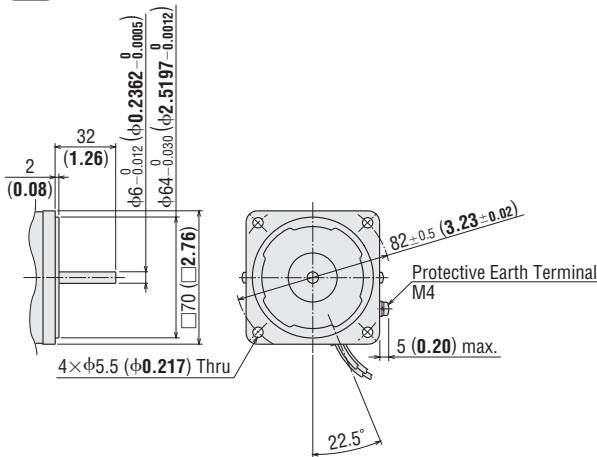

### ◇ Decimal Gearhead

Can be connected to **GN** pinion shaft type.

**3GN10XS**

Mass: 0.3 kg (0.66 lb.)

**DXF** A009

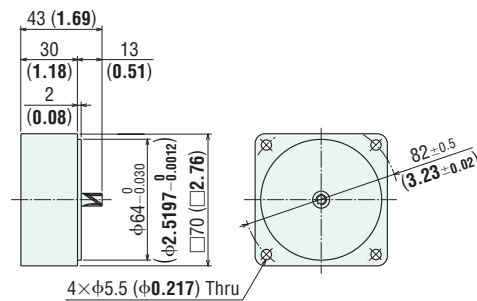

### ◇ Capacitor (Included)

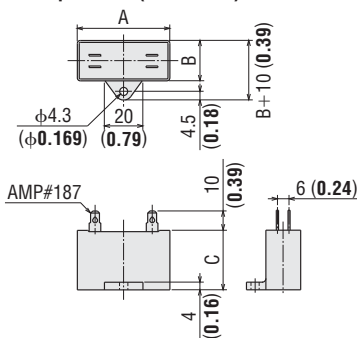

### ◇ Capacitor Dimensions Unit = mm (in.)

Model		Capacitor Model	A	B	C	Mass g (oz.)	Capacitor Cap
Pinion Shaft Type	Round Shaft Type						
<b>3RK15GN-AW2MU</b>	<b>3RK15A-AW2MU</b>	CH60CFAUL2	38 (1.50)	21 (0.83)	31 (1.22)	35 (1.24)	Included
<b>3RK15GN-CW2ME</b>	<b>3RK15A-CW2ME</b>	CH15BFAUL	38 (1.50)	21 (0.83)	31 (1.22)	37 (1.31)	

## Connection Diagrams

- The direction of motor rotation is as viewed from the shaft end of the motor. CW represents the clockwise direction, while CCW represents the counterclockwise direction.
- Connection diagrams are also valid for the equivalent round shaft type.

**3RK15GN-AW2MU**  
**3RK15GN-CW2ME**

SW1 operates both motor and electromagnetic brake action. The electromagnetic brake will be released and the motor will rotate when SW1 is switched simultaneously to ON. When SW1 is switched simultaneously to OFF, the motor stops immediately with the electromagnetic brake and holds the load.

If you wish to release the brake while the motor is stopped, apply voltage between the two brake lead wires (orange).

**Rotation Direction**  
To rotate the motor in a clockwise (CW) direction, turn SW2 to CW.  
To rotate the motor in a counterclockwise (CCW) direction, turn SW2 to CCW.

Switch No.	Specifications		Note
	Single-Phase 110/115 VAC Input	Single-Phase 220/230 VAC Input	
SW1	125 VAC 3 A minimum	250 VAC 1.5 A minimum	Switched Simultaneously
SW2	(Inductive Load)	(Inductive Load)	—

PE: Protective Earth

- $R_0$  and  $C_0$  indicate CR circuit for surge suppression. [ $R_0 = 5 \sim 200 \Omega$ ,  $C_0 = 0.1 \sim 0.2 \mu\text{F}$ , 200 WV (400 WV)]

**EPCR1201-2** (CR circuit) is available as an accessory. → Page A-302

- How to connect a capacitor → Page A-313

### Accessories and Peripheral Equipment

Instantaneous Stop  
Brake Pack  
→ Page A-277

Accessories  
→ Page A-287

## Power Off Activated Type Electromagnetic Brake Motors

## 25 W (1/30 HP)

Frame Size: □80 mm (□3.15 in.)



(Gearhead sold separately)

## Specifications

### ● Motor (RoHS)

● This type of motor does not contain a built-in friction brake mechanism.



Model		Rating	Output Power W HP	Voltage	Frequency Hz	Current A	Starting Torque mN·m oz-in	Rated Torque mN·m oz-in	Rated Speed r/min	Capacitor μF
Pinion Shaft Type	Round Shaft Type			VAC						
TP	4RK25GN-AW2MU	30 minutes	25 1/30	Single-Phase 110	60	0.54	140 19.8	170 24	1450	8.0
				Single-Phase 115						
TP	4RK25GN-CW2ME	30 minutes	25 1/30	Single-Phase 220	60	0.28	140 19.8	170 24	1450	2.0
				Single-Phase 230						
				60	0.28	140 19.8	170 24	1450		
TP	4IK25GN-SW2M	Continuous	25 1/30	Three-Phase 200	50	0.23	240 34	190 26	1300	-
					60		160 22	160 22	1550	
				60	0.20	160	150	1600		
					0.21	22	21			

● The **U** and **E** at the end of the model name indicate that the unit includes a capacitor. These letters are not listed on the motor nameplate. When the motor is approved under various safety standards, the model name on the nameplate is the approved model name. → Page G-11

● Details of safety standards → Page G-2

● Details of RoHS Directive → Page G-38

TP: Contains a built-in thermal protector (automatic return type). If a motor overheats for any reason, the thermal protector is activated and the motor is stopped. (The power supply to the electromagnetic brake is kept and the brake is released.)

When the motor temperature drops, the thermal protector closes and the motor restarts. Be sure to turn the motor power off before inspecting.

### ● Electromagnetic Brake (Power Off Activated Type)

Motor Model	Voltage VAC	Frequency Hz	Current A	Input W	Holding Brake Torque mN·m oz-in	
4RK25GN-AW2MU 4RK25A-AW2MU	Single-Phase 110	60	0.09	6	100	
	Single-Phase 115				14.2	
4RK25GN-CW2ME 4RK25A-CW2ME	Single-Phase 220	60	0.05	7	100	
	Single-Phase 230				50	14.2
					60	
4IK25GN-SW2M 4IK25A-SW2M	Single-Phase 200	50	0.05	7	100	
		60			14.2	
	Single-Phase 220	60				
		Single-Phase 230				

## Product Line

### ● Motor (RoHS)

Model	
Pinion Shaft Type	Round Shaft Type
4RK25GN-AW2MU	4RK25A-AW2MU
4RK25GN-CW2ME	4RK25A-CW2ME
4IK25GN-SW2M	4IK25A-SW2M

—The following items are included in each product.—

Motor, Capacitor\*, Capacitor Cap\*, Operating Manual

\*Only for single-phase motors



● Parallel Shaft Gearhead/Right-Angle Gearhead  
(Sold separately) (RoHS)

Gearhead Type		Gearhead Model	Gear Ratio
Parallel Shaft	Long Life, Low Noise <b>GN-S</b> Gearhead	<b>4GN□SA</b>	<b>3, 3.6, 5, 6, 7.5, 9, 12.5, 15, 18, 25, 30, 36, 50, 60, 75, 90, 100, 120, 150, 180</b>
	Hollow Shaft	<b>4GN□RH</b>	
Right-Angle Shaft	Solid Shaft	<b>4GN□RAA</b>	
Parallel Shaft	Long Life, Low Noise <b>GN-S</b> Gearhead	<b>4GN10XS</b> (Decimal Gearhead)	

● Enter the gear ratio in the box (□) within the model name.

The following items are included in each product.

- Parallel Shaft Gearhead  
Gearhead, Mounting Screws, Operating Manual
- Hollow Shaft Gearhead  
Gearhead, Mounting Screws, Parallel Key, Safety Cover (with screws), Gasket, Operating Manual
- Solid Shaft Gearhead  
Gearhead, Mounting Screws, Gasket, Operating Manual

● Following gearheads are also available. For details, please refer to website (http://www.orientalmotor.com/) or contact the nearest Oriental Motor sales office.

Gearhead Type		Gearhead Model	Gear Ratio
Parallel Shaft	(RoHS) <b>GN-K</b> Gearhead	<b>4GN□KA</b>	<b>3~180</b>
		<b>4GN10XK</b> (Decimal Gearhead)	

● Enter the gear ratio in the box (□) within the model name.

## ■ Gearmotor – Torque Table

- Gearheads and decimal gearheads are sold separately.
- Enter the gear ratio in the box (□) within the gearhead model name.
- A colored background (□) indicates gear shaft rotation in the same direction as the motor shaft, while the others rotate in the opposite direction.
- The speed is calculated by dividing the motor's synchronous speed (50 Hz: 1500 r/min, 60 Hz: 1800 r/min) by the gear ratio. The actual speed is 2~20% less than the displayed value, depending on the load.
- To reduce the speed beyond the gear ratio in the table, attach a decimal gearhead (gear ratio 10:1) between the gearhead and the motor. In that case, the permissible torque is 8 N·m (70 lb-in). When a gearhead of 25:1~36:1 is connected, the value for permissible torque is 6 N·m (53 lb-in).

### ◇ 50 Hz

Unit = Upper values: N·m/Lower values: lb-in

Model Motor/ Gearhead	Speed r/min	500	416	300	250	200	166	120	100	83	60	50	41	30	25	20	16	15	12.5	10	8.3
	Gear Ratio	<b>3</b>	<b>3.6</b>	<b>5</b>	<b>6</b>	<b>7.5</b>	<b>9</b>	<b>12.5</b>	<b>15</b>	<b>18</b>	<b>25</b>	<b>30</b>	<b>36</b>	<b>50</b>	<b>60</b>	<b>75</b>	<b>90</b>	<b>100</b>	<b>120</b>	<b>150</b>	<b>180</b>
<b>4RK25GN-CW2ME</b> / <b>4GN□SA</b>	0.50 4.4	0.60 5.3	0.83 7.3	1.0 8.8	1.2 10.6	1.5 13.2	2.1 18.5	2.5 22	3.0 26	3.7 32	4.5 39	5.4 47	6.8 60	8 70	8 70	8 70	8 70	8 70	8 70	8 70	8 70
<b>4IK25GN-SW2M</b> / <b>4GN□SA</b>	0.46 4.0	0.55 4.8	0.77 6.8	0.92 8.1	1.2 10.6	1.4 12.3	1.9 16.8	2.3 20	2.8 24	3.5 30	4.2 37	5.0 44	6.3 55	7.5 66	8 70	8 70	8 70	8 70	8 70	8 70	8 70

### ◇ 60 Hz

Unit = Upper values: N·m/Lower values: lb-in

Model Motor/ Gearhead	Speed r/min	600	500	360	300	240	200	144	120	100	72	60	50	36	30	24	20	18	15	12	10
	Gear Ratio	<b>3</b>	<b>3.6</b>	<b>5</b>	<b>6</b>	<b>7.5</b>	<b>9</b>	<b>12.5</b>	<b>15</b>	<b>18</b>	<b>25</b>	<b>30</b>	<b>36</b>	<b>50</b>	<b>60</b>	<b>75</b>	<b>90</b>	<b>100</b>	<b>120</b>	<b>150</b>	<b>180</b>
<b>4RK25GN-AW2MU</b> / <b>4GN□SA</b>	0.41 3.6	0.50 4.4	0.69 6.1	0.83 7.3	1.0 8.8	1.2 10.6	1.7 15.0	2.1 18.5	2.5 22	3.1 27	3.7 32	4.5 39	5.6 49	6.7 59	8 70	8 70	8 70	8 70	8 70	8 70	8 70
<b>4IK25GN-SW2M</b> / <b>4GN□SA</b>	0.39 3.4	0.47 4.1	0.65 5.7	0.78 6.9	0.97 8.5	1.2 10.6	1.6 14.1	1.9 16.8	2.3 20	2.9 25	3.5 30	4.2 37	5.3 46	6.3 55	7.9 69	8 70	8 70	8 70	8 70	8 70	8 70
<b>4IK25GN-SW2M</b> / <b>4GN□SA</b>	0.36 3.1	0.44 3.8	0.61 5.3	0.73 6.4	0.91 8.0	1.1 9.7	1.5 13.2	1.8 15.9	2.2 19.4	2.7 23	3.3 29	3.9 34	5.0 44	5.9 52	7.4 65	8 70	8 70	8 70	8 70	8 70	8 70

## ■ Gearmotor – Torque Table When Right-Angle Gearhead is Attached

→ Page A-250

## ■ Permissible Overhung Load and Permissible Thrust Load

Motor (Round shaft type) → Page A-16

Gearhead → Page A-16

## ■ Permissible Load Inertia J of Gearhead

→ Page A-17

## Starting and Braking Characteristics (Reference values)

### Single-Phase Motor

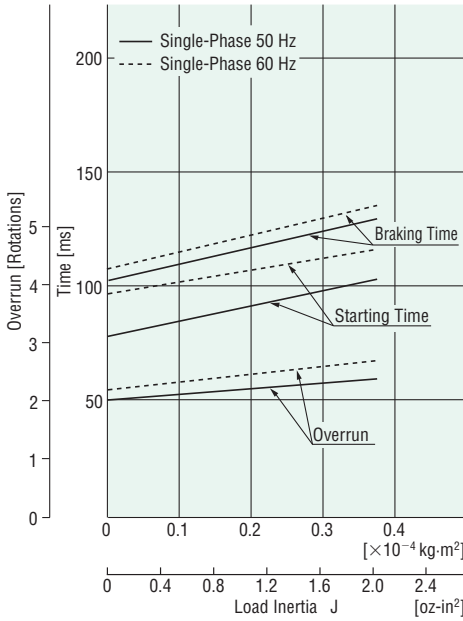

### Three-Phase Motor

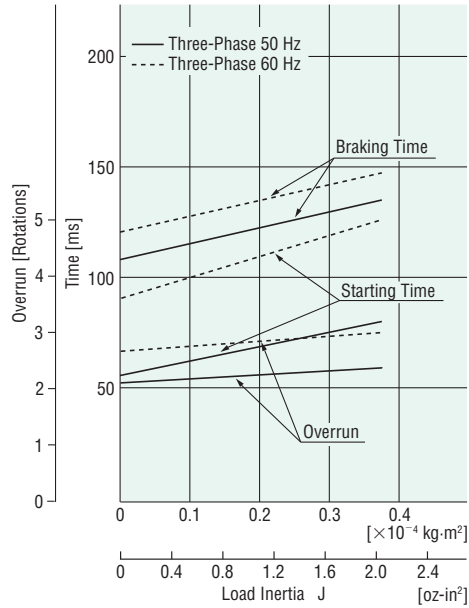

## Dimensions Unit = mm (in.)

● Mounting screws are included with gearheads. Dimensions for mounting screws → Page A-310

### ◇ Motor/Gearhead

Mass: Motor 2.0 kg (4.4 lb.)  
Gearhead 0.65 kg (1.43 lb.)

Motor Model	Gearhead Model	Gear Ratio	L	DXF
<b>4RK25GN-AW2MU</b> <b>4RK25GN-CW2ME</b> <b>4IK25GN-SW2M</b>	<b>4GN□SA</b>	<b>3~18</b>	32 (1.26)	A466AU
		<b>25~180</b>	42.5 (1.67)	A466BU

● Enter the gear ratio in the box (□) within the model name.

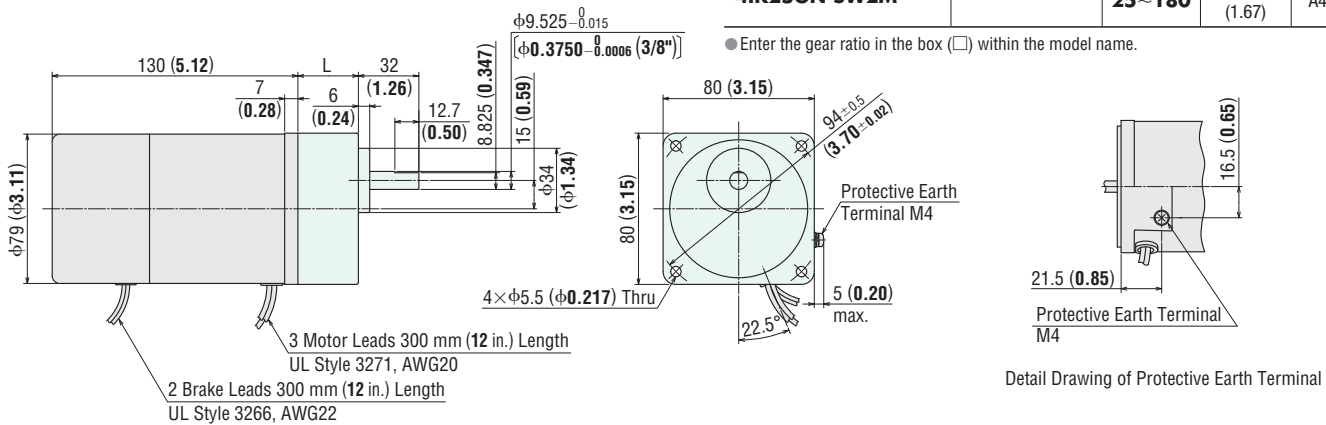

### ◇ Shaft Section of Round Shaft Type

The motor's dimensions (excluding the shaft section) are the same as those of the pinion shaft types.

Mass: 2.0 kg (4.4 lb.)

**DXF** A467

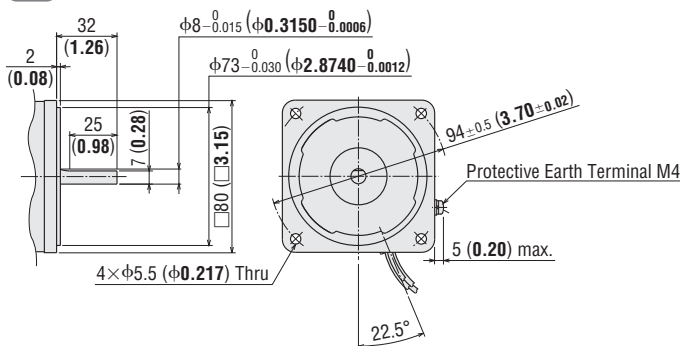

### ◇ Decimal Gearhead

Can be connected to **GN** pinion shaft type.

**4GN10XS**

Mass: 0.4 kg (0.88 lb.)

**DXF** A013

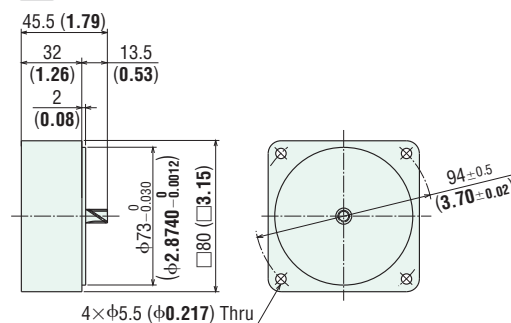

◇ Capacitor  
(Included with single-phase motors)

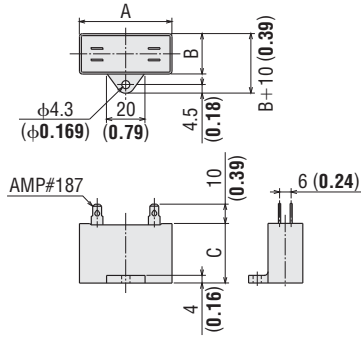

◇ Capacitor Dimensions Unit = mm (in.)

Model		Capacitor Model	A	B	C	Mass g (oz.)	Capacitor Cap
Pinion Shaft Type	Round Shaft Type						
<b>4RK25GN-AW2MU</b>	<b>4RK25A-AW2MU</b>	CH80CFAUL2	48 (1.89)	21 (0.83)	31 (1.22)	41 (1.45)	Included
<b>4RK25GN-CW2ME</b>	<b>4RK25A-CW2ME</b>	CH20BFAUL	48 (1.89)	19 (0.75)	29 (1.14)	36 (1.27)	

■ Connection Diagrams

- The direction of motor rotation is as viewed from the shaft end of the motor. CW represents the clockwise direction, while CCW represents the counterclockwise direction.
- Connection diagrams are also valid for the equivalent round shaft type.

Single-Phase Motor	<b>4RK25GN-AW2MU</b> <b>4RK25GN-CW2ME</b>	<p>SW1 operates both motor and electromagnetic brake action. The electromagnetic brake will be released and the motor will rotate when SW1 is switched simultaneously to ON. When SW1 is switched simultaneously to OFF, the motor stops immediately with the electromagnetic brake and holds the load.</p> <p>If you wish to release the brake while the motor is stopped, apply voltage between the two brake lead wires (orange).</p> <p>Rotation Direction To rotate the motor in a clockwise (CW) direction, turn SW2 to CW. To rotate the motor in a counterclockwise (CCW) direction, turn SW2 to CCW.</p> <table border="1" style="width: 100%; border-collapse: collapse;"> <thead> <tr> <th rowspan="2">Switch No.</th> <th colspan="2">Specifications</th> <th rowspan="2">Note</th> </tr> <tr> <th>Single-Phase 110/115 VAC Input</th> <th>Single-Phase 220/230 VAC Input</th> </tr> </thead> <tbody> <tr> <td>SW1</td> <td>125 VAC 3 A minimum (Inductive Load)</td> <td>250 VAC 1.5 A minimum (Inductive Load)</td> <td>Switched Simultaneously</td> </tr> <tr> <td>SW2</td> <td></td> <td></td> <td>—</td> </tr> </tbody> </table>	Switch No.	Specifications		Note	Single-Phase 110/115 VAC Input	Single-Phase 220/230 VAC Input	SW1	125 VAC 3 A minimum (Inductive Load)	250 VAC 1.5 A minimum (Inductive Load)	Switched Simultaneously	SW2			—
Switch No.	Specifications			Note												
	Single-Phase 110/115 VAC Input	Single-Phase 220/230 VAC Input														
SW1	125 VAC 3 A minimum (Inductive Load)	250 VAC 1.5 A minimum (Inductive Load)	Switched Simultaneously													
SW2			—													
Three-Phase Motor	<b>4IK25GN-SW2M</b>	<p>SW1 operates both motor and electromagnetic brake action. The electromagnetic brake will be released and the motor will rotate when SW1 is switched simultaneously to ON. When SW1 is switched simultaneously to OFF, the motor stops immediately with the electromagnetic brake and holds the load.</p> <p>If you wish to release the brake while the motor is stopped, apply voltage between the two brake lead wires (orange).</p> <p>Rotation Direction To change the rotation direction, change any two connections between L1(R), L2(S) and L3(T).</p> <table border="1" style="width: 100%; border-collapse: collapse;"> <thead> <tr> <th>Switch No.</th> <th>Specifications</th> <th>Note</th> </tr> </thead> <tbody> <tr> <td>SW1</td> <td>250 VAC 1.5 A minimum (Inductive Load)</td> <td>Switched Simultaneously</td> </tr> </tbody> </table>	Switch No.	Specifications	Note	SW1	250 VAC 1.5 A minimum (Inductive Load)	Switched Simultaneously								
Switch No.	Specifications	Note														
SW1	250 VAC 1.5 A minimum (Inductive Load)	Switched Simultaneously														

PE: Protective Earth

● Ro and Co indicate CR circuit for surge suppression. [Ro = 5~200 Ω, Co = 0.1~0.2 μF, 200 WV (400 WV)]

● EPCR1201-2 (CR circuit) is available as an accessory. → Page A-302

● How to connect a capacitor → Page A-313

■ Gearhead, Linear Head, Accessories and Peripheral Equipment

<p>Space-Saving Right-Angle Gearheads → Page A-239</p>	<p>Linear Motion Linear Heads → Page A-259</p>	<p>Instantaneous Stop Brake Pack → Page A-277</p>	<p>Accessories → Page A-287</p>
----------------------------------------------------------------	--------------------------------------------------------	-----------------------------------------------------------	-------------------------------------

## Power Off Activated Type Electromagnetic Brake Motors

## 40 W (1/19 HP)

Frame Size: □90 mm (□3.54 in.)



(Gearhead sold separately)

## Specifications

### ● Motor (RoHS)

● This type of motor does not contain a built-in friction brake mechanism.



Model		Rating	Output Power W HP	Voltage VAC	Frequency Hz	Current A	Starting Torque mN·m oz-in	Rated Torque mN·m oz-in	Rated Speed r/min	Capacitor μF
Pinion Shaft Type	Round Shaft Type									
TP	5RK40GN-AW2MU 5RK40A-AW2MU	30 minutes	40 1/19	Single-Phase 110	60	0.81	260 36	270 38	1450	12
				Single-Phase 115						
TP	5RK40GN-CW2ME 5RK40A-CW2ME	30 minutes	40 1/19	Single-Phase 220	60	0.43	260 36	260 36	1500	3.5
				Single-Phase 230						
				Single-Phase 230						
TP	5IK40GN-SW2M 5IK40A-SW2M	Continuous	40 1/19	Three-Phase 200	50	0.32	400 56	300 42	1300	-
				Three-Phase 220	60	0.30	260 36	260 36	1550	
				Three-Phase 220	60	0.30	260 36	260 36	1600	
				Three-Phase 230						

● The **U** and **E** at the end of the model name indicate that the unit includes a capacitor. These letters are not listed on the motor nameplate. When the motor is approved under various safety standards, the model name on the nameplate is the approved model name. → Page G-11

● Details of safety standards → Page G-2

● Details of RoHS Directive → Page G-38

TP: Contains a built-in thermal protector (automatic return type). If a motor overheats for any reason, the thermal protector is activated and the motor is stopped. (The power supply to the electromagnetic brake is kept and the brake is released.)

When the motor temperature drops, the thermal protector closes and the motor restarts. Be sure to turn the motor power off before inspecting.

### ● Electromagnetic Brake (Power Off Activated Type)

Motor Model	Voltage	Frequency Hz	Current A	Input W	Holding Brake Torque mN·m oz-in
	VAC				
5RK40GN-AW2MU 5RK40A-AW2MU	Single-Phase 110	60	0.09	6	200 28
	Single-Phase 115				
5RK40GN-CW2ME 5RK40A-CW2ME	Single-Phase 220	60	0.05	7	200 28
	Single-Phase 230				
	Single-Phase 230				
5IK40GN-SW2M 5IK40A-SW2M	Single-Phase 200	60	0.05	7	200 28
	Single-Phase 200				
	Single-Phase 220				
	Single-Phase 230				

## Product Line

### ● Motor (RoHS)

Model	
Pinion Shaft Type	Round Shaft Type
<b>5RK40GN-AW2MU</b>	<b>5RK40A-AW2MU</b>
<b>5RK40GN-CW2ME</b>	<b>5RK40A-CW2ME</b>
<b>5IK40GN-SW2M</b>	<b>5IK40A-SW2M</b>

The following items are included in each product.  
 Motor, Capacitor\*, Capacitor Cap\*, Operating Manual  
 \*Only for single-phase motors

### ● Parallel Shaft Gearhead/Right-Angle Gearhead (Sold separately) (RoHS)

Gearhead Type		Gearhead Model	Gear Ratio
Parallel Shaft	Long Life, Low Noise <b>GN-S</b> Gearhead	<b>5GN□SA</b>	<b>3, 3.6, 5, 6, 7.5, 9, 12.5, 15, 18, 25, 30, 36, 50, 60, 75, 90, 100, 120, 150, 180</b>
Right-Angle Shaft	Hollow Shaft	<b>5GN□RH</b>	
	Solid Shaft	<b>5GN□RAA</b>	
Parallel Shaft	Long Life, Low Noise <b>GN-S</b> Gearhead	<b>5GN10XS</b> (Decimal Gearhead)	

● Enter the gear ratio in the box (□) within the model name.

The following items are included in each product.

- Parallel Shaft Gearhead  
Gearhead, Mounting Screws, Operating Manual
- Hollow Shaft Gearhead  
Gearhead, Mounting Screws, Parallel Key, Safety Cover (with screws), Gasket, Operating Manual
- Solid Shaft Gearhead  
Gearhead, Mounting Screws, Gasket, Operating Manual

● Following gearheads are also available. For details, please refer to website (<http://www.orientalmotor.com/>) or contact the nearest Oriental Motor sales office.

Gearhead Type		Gearhead Model	Gear Ratio
Parallel Shaft	(RoHS) <b>GN-K</b> Gearhead	<b>5GN□KA</b>	<b>3~180</b>
		<b>5GN10XK</b> (Decimal Gearhead)	

● Enter the gear ratio in the box (□) within the model name.

## Gearmotor – Torque Table

- Gearheads and decimal gearheads are sold separately.
- Enter the gear ratio in the box (□) within the gearhead model name.
- A colored background (□) indicates gear shaft rotation in the same direction as the motor shaft, while the others rotate in the opposite direction.
- The speed is calculated by dividing the motor's synchronous speed (50 Hz: 1500 r/min, 60 Hz: 1800 r/min) by the gear ratio. The actual speed is 2~20% less than the displayed value, depending on the load.
- To reduce the speed beyond the gear ratio in the table, attach a decimal gearhead (gear ratio 10:1) between the gearhead and the motor. In that case, the permissible torque is 10 N·m (88 lb-in).

### ◇ 50 Hz

Unit = Upper values: N-m/Lower values: lb-in

Model Motor/ Gearhead	Speed r/min	Gear Ratio																		
		500	416	300	250	200	166	120	100	83	60	50	41	30	25	20	16	15	12.5	10
<b>5RK40GN-CW2ME</b> / <b>5GN□SA</b>	0.77	0.92	1.3	1.5	1.9	2.3	3.2	3.8	4.6	5.7	6.9	8.3	10	10	10	10	10	10	10	10
	6.8	8.1	11.5	13.2	16.8	20	28	33	40	50	61	73	88	88	88	88	88	88	88	88
<b>5IK40GN-SW2M</b> / <b>5GN□SA</b>	0.73	0.87	1.2	1.5	1.8	2.2	3.0	3.6	4.4	5.5	6.6	7.9	9.9	10	10	10	10	10	10	10
	6.4	7.6	10.6	13.2	15.9	19.4	26	31	38	48	58	69	87	88	88	88	88	88	88	88

### ◇ 60 Hz

Unit = Upper values: N-m/Lower values: lb-in

Model Motor/ Gearhead	Speed r/min	Gear Ratio																		
		600	500	360	300	240	200	144	120	100	72	60	50	36	30	24	20	18	15	12
<b>5RK40GN-AW2MU</b> / <b>5GN□SA</b>	0.66	0.79	1.1	1.3	1.6	2.0	2.7	3.3	3.9	4.9	5.9	7.1	8.9	10	10	10	10	10	10	10
	5.8	6.9	9.7	11.5	14.1	17.7	23	29	34	43	52	62	78	88	88	88	88	88	88	88
<b>5RK40GN-CW2ME</b> / <b>5GN□SA</b>	0.63	0.76	1.1	1.3	1.6	1.9	2.6	3.2	3.8	4.7	5.7	6.8	8.6	10	10	10	10	10	10	10
	5.5	6.7	9.7	11.5	14.1	16.8	23	28	33	41	50	60	76	88	88	88	88	88	88	88



◇ Shaft Section of Round Shaft Type

The motor's dimensions (excluding the shaft section) are the same as those of the pinion shaft types.

Mass: 2.8 kg (6.2 lb.)

**DXF** A469

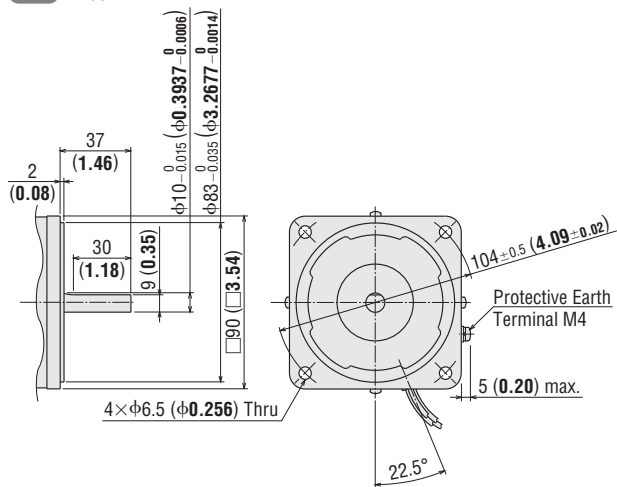

◇ Decimal Gearhead

Can be connected to **GN** pinion shaft type.

**5GN10XS**

Mass: 0.6 kg (1.32 lb.)

**DXF** A022

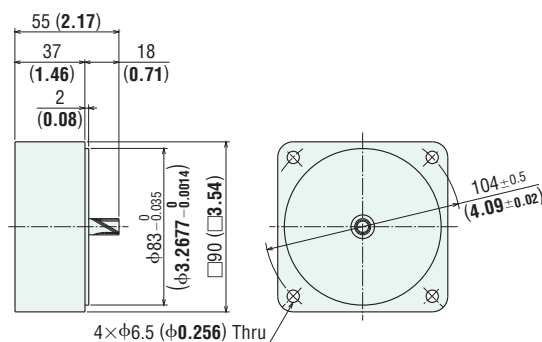

◇ Capacitor (Included with single-phase motors)

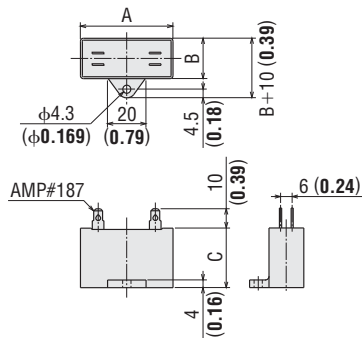

◇ Capacitor Dimensions Unit = mm (in.)

Model		Capacitor Model	A	B	C	Mass g (oz.)	Capacitor Cap
Pinion Shaft Type	Round Shaft Type						
<b>5RK40GN-AW2MU</b>	<b>5RK40A-AW2MU</b>	CH120CFAUL2	58 (2.28)	22 (0.87)	35 (1.38)	60 (2.1)	Included
<b>5RK40GN-CW2ME</b>	<b>5RK40A-CW2ME</b>	CH35BFAUL	58 (2.28)	22 (0.87)	35 (1.38)	59 (2.1)	



## Connection Diagrams

- The direction of motor rotation is as viewed from the shaft end of the motor. CW represents the clockwise direction, while CCW represents the counterclockwise direction.
- Connection diagrams are also valid for the equivalent round shaft type.

<p>Single-Phase Motor</p> <p><b>5RK40GN-AW2MU</b> <b>5RK40GN-CW2ME</b></p>		<p>SW1 operates both motor and electromagnetic brake action. The electromagnetic brake will be released and the motor will rotate when SW1 is switched simultaneously to ON.</p> <p>When SW1 is switched simultaneously to OFF, the motor stops immediately with the electromagnetic brake and holds the load.</p> <p>If you wish to release the brake while the motor is stopped, apply voltage between the two brake lead wires (orange).</p> <p>Rotation Direction To rotate the motor in a clockwise (CW) direction, turn SW2 to CW. To rotate the motor in a counterclockwise (CCW) direction, turn SW2 to CCW.</p>												
	<table border="1"> <thead> <tr> <th rowspan="2">Switch No.</th> <th colspan="2">Specifications</th> <th rowspan="2">Note</th> </tr> <tr> <th>Single-Phase 110/115 VAC Input</th> <th>Single-Phase 220/230 VAC Input</th> </tr> </thead> <tbody> <tr> <td>SW1</td> <td>125 VAC 5 A minimum (Inductive Load)</td> <td>250 VAC 5 A minimum (Inductive Load)</td> <td>Switched Simultaneously</td> </tr> <tr> <td>SW2</td> <td></td> <td></td> <td>—</td> </tr> </tbody> </table>	Switch No.	Specifications		Note	Single-Phase 110/115 VAC Input	Single-Phase 220/230 VAC Input	SW1	125 VAC 5 A minimum (Inductive Load)	250 VAC 5 A minimum (Inductive Load)	Switched Simultaneously	SW2		
Switch No.	Specifications		Note											
	Single-Phase 110/115 VAC Input	Single-Phase 220/230 VAC Input												
SW1	125 VAC 5 A minimum (Inductive Load)	250 VAC 5 A minimum (Inductive Load)	Switched Simultaneously											
SW2			—											
<p>Three-Phase Motor</p> <p><b>5IK40GN-SW2M</b></p>		<p>SW1 operates both motor and electromagnetic brake action. The electromagnetic brake will be released and the motor will rotate when SW1 is switched simultaneously to ON.</p> <p>When SW1 is switched simultaneously to OFF, the motor stops immediately with the electromagnetic brake and holds the load.</p> <p>If you wish to release the brake while the motor is stopped, apply voltage between the two brake lead wires (orange).</p> <p>Rotation Direction To change the rotation direction, change any two connections between L1(R), L2(S) and L3(T).</p>												
	<table border="1"> <thead> <tr> <th rowspan="2">Switch No.</th> <th colspan="2">Specifications</th> <th rowspan="2">Note</th> </tr> <tr> <th colspan="2">250 VAC 5 A minimum (Inductive Load)</th> </tr> </thead> <tbody> <tr> <td>SW1</td> <td></td> <td></td> <td>Switched Simultaneously</td> </tr> </tbody> </table>	Switch No.	Specifications		Note	250 VAC 5 A minimum (Inductive Load)		SW1			Switched Simultaneously			
Switch No.	Specifications		Note											
	250 VAC 5 A minimum (Inductive Load)													
SW1			Switched Simultaneously											

PE: Protective Earth

●  $R_o$  and  $C_o$  indicate CR circuit for surge suppression. [ $R_o = 5 \sim 200 \Omega$ ,  $C_o = 0.1 \sim 0.2 \mu F$ , 200 WV (400 WV)]

● **EPCR1201-2** (CR circuit) is available as an accessory. → Page A-302

● How to connect a capacitor → Page A-313

### Gearhead, Accessories and Peripheral Equipment

<p><b>Space-Saving</b> Right-Angle Gearheads → Page A-239</p>	<p><b>Instantaneous Stop</b> Brake Pack → Page A-277</p>	<p><b>Accessories</b> → Page A-287</p>
-----------------------------------------------------------------------	------------------------------------------------------------------	--------------------------------------------



# Power Off Activated Type Electromagnetic Brake Motors

## 60 W (1/12 HP)

Frame Size: □90 mm (□3.54 in.)



(Gearhead sold separately)

### Specifications

● Motor (RoHS)

● This type of motor does not contain a built-in friction brake mechanism.



Model		Rating	Output Power W HP	Voltage VAC	Frequency Hz	Current A	Starting Torque mN·m oz·in	Rated Torque mN·m oz·in	Rated Speed r/min	Capacitor μF				
Pinion Shaft Type	Round Shaft Type													
ⓉP	<b>5RK60GE-AW2MU</b> <b>5RK60A-AW2MU</b>	30 minutes	60 1/12	Single-Phase 110	60	1.24	380 53	405 57	1450	20				
				Single-Phase 115										
ⓉP	<b>5RK60GE-CW2ME</b> <b>5RK60A-CW2ME</b>	30 minutes	60 1/12	Single-Phase 220	60	0.61	380 53	405 57	1450	5.0				
				Single-Phase 230							50	470 66	490 69	1200
											60	0.61	380 53	405 57
ⓉP	<b>5IK60GE-SW2M</b> <b>5IK60A-SW2M</b>	Continuous	60 1/12	Three-Phase 200	50	0.50	600 85	450 63	1300	-				
					60	0.43	500 71	380 53	1550					
				Three-Phase 220	60	0.45	500	380	1600					
						0.46	71	53						

● The **U** and **E** at the end of the model name indicate that the unit includes a capacitor. These letters are not listed on the motor nameplate. When the motor is approved under various safety standards, the model name on the nameplate is the approved model name. → Page G-11

● Details of safety standards → Page G-2

● Details of RoHS Directive → Page G-38

ⓉP: Contains a built-in thermal protector (automatic return type). If a motor overheats for any reason, the thermal protector is activated and the motor is stopped. (The power supply to the electromagnetic brake is kept and the brake is released.)

When the motor temperature drops, the thermal protector closes and the motor restarts. Be sure to turn the motor power off before inspecting.

### Electromagnetic Brake (Power Off Activated Type)

Motor Model	Voltage VAC	Frequency Hz	Current A	Input W	Holding Brake Torque mN·m oz·in	
<b>5RK60GE-AW2MU</b> <b>5RK60A-AW2MU</b>	Single-Phase 110	60	0.13	10	500	
	Single-Phase 115				71	
<b>5RK60GE-CW2ME</b> <b>5RK60A-CW2ME</b>	Single-Phase 220	60	0.07	10	500	
	Single-Phase 230				50	71
					60	
<b>5IK60GE-SW2M</b> <b>5IK60A-SW2M</b>	Single-Phase 200	60	0.07	10	500	
	Single-Phase 220				71	
	Single-Phase 230					

## Product Line

### ● Motor (RoHS)

Model	
Pinion Shaft Type	Round Shaft Type
<b>5RK60GE-AW2MU</b>	<b>5RK60A-AW2MU</b>
<b>5RK60GE-CW2ME</b>	<b>5RK60A-CW2ME</b>
<b>5IK60GE-SW2M</b>	<b>5IK60A-SW2M</b>

The following items are included in each product. —

Motor, Capacitor\*, Capacitor Cap\*, Operating Manual

\*Only for single-phase motors

### ● Parallel Shaft Gearhead/Right-Angle Gearhead (Sold separately) (RoHS)

Gearhead Type		Gearhead Model	Gear Ratio
Parallel Shaft	Long Life <b>GE-S</b> Gearhead	<b>5GE□SA</b>	<b>3, 3.6, 5, 6, 7.5, 9, 12.5, 15, 18, 25, 30, 36, 50, 60, 75, 90, 100, 120, 150, 180</b>
	Right-Angle Shaft	Hollow Shaft	
Solid Shaft		<b>5GE□RAA</b>	
Parallel Shaft	Long Life <b>GE-S</b> Gearhead	<b>5GE10XS</b> (Decimal Gearhead)	

● Enter the gear ratio in the box (□) within the model name.

The following items are included in each product. —

#### ● Parallel Shaft Gearhead

Gearhead, Mounting Screws, Parallel Key, Operating Manual

#### ● Hollow Shaft Gearhead

Gearhead, Mounting Screws, Parallel Key, Safety Cover (with screws), Gasket, Operating Manual

#### ● Solid Shaft Gearhead

Gearhead, Mounting Screws, Parallel Key, Gasket, Operating Manual

## Gearmotor – Torque Table

- Gearheads and decimal gearheads are sold separately.
- Enter the gear ratio in the box (□) within the gearhead model name.
- A colored background (□) indicates gear shaft rotation in the same direction as the motor shaft, while the others rotate in the opposite direction.
- The speed is calculated by dividing the motor's synchronous speed (50 Hz: 1500 r/min, 60 Hz: 1800 r/min) by the gear ratio.  
The actual speed is 2~20% less than the displayed value, depending on the load.
- To reduce the speed beyond the gear ratio in the table, attach a decimal gearhead (gear ratio 10:1) between the gearhead and the motor.  
In that case, the permissible torque is 20 N·m (177 lb-in).

### ◇ 50 Hz

Unit = Upper values: N-m/Lower values: lb-in

Model	Speed r/min	Gear Ratio																			
		500	416	300	250	200	166	120	100	83	60	50	41	30	25	20	16	15	12.5	10	8.3
<b>5RK60GE-CW2ME</b>	<b>5GE□SA</b>	1.2	1.4	2.0	2.4	3.0	3.6	4.5	5.4	6.4	8.1	9.7	11.6	16.2	19.4	20	20	20	20	20	20
		10.6	12.3	17.7	21	26	31	39	47	56	71	85	102	143	171	177	177	177	177	177	177
<b>5IK60GE-SW2M</b>	<b>5GE□SA</b>	1.1	1.3	1.8	2.2	2.7	3.3	4.1	4.9	5.9	7.4	8.9	10.7	14.9	17.8	19.9	20	20	20	20	20
		9.7	11.5	15.9	19.7	23	29	36	43	52	65	78	94	131	157	176	177	177	177	177	177

### ◇ 60 Hz

Unit = Upper values: N-m/Lower values: lb-in

Model	Speed r/min	Gear Ratio																			
		600	500	360	300	240	200	144	120	100	72	60	50	36	30	24	20	18	15	12	10
<b>5RK60GE-AW2MU</b> <b>5RK60GE-CW2ME</b>	<b>5GE□SA</b>	0.98	1.2	1.6	2.0	2.5	3.0	3.7	4.4	5.3	6.7	8.0	9.6	13.4	16.0	17.9	20	20	20	20	20
		8.6	10.6	14.1	17.7	22	26	32	38	46	59	70	84	118	141	158	177	177	177	177	177
<b>5IK60GE-SW2M</b>	<b>5GE□SA</b>	0.92	1.1	1.5	1.8	2.3	2.8	3.5	4.2	5.0	6.3	7.5	9.0	12.5	15.0	16.8	20	20	20	20	20
		8.1	9.7	13.2	15.9	20	24	30	37	44	55	66	79	110	132	148	177	177	177	177	177

## Gearmotor – Torque Table When Right-Angle Gearhead is Attached

→ Page A-250

## Permissible Overhung Load and Permissible Thrust Load

Motor (Round shaft type) → Page A-16

Gearhead → Page A-16

## Permissible Load Inertia J of Gearhead

→ Page A-17

## Starting and Braking Characteristics (Reference values)

### Single-Phase Motor

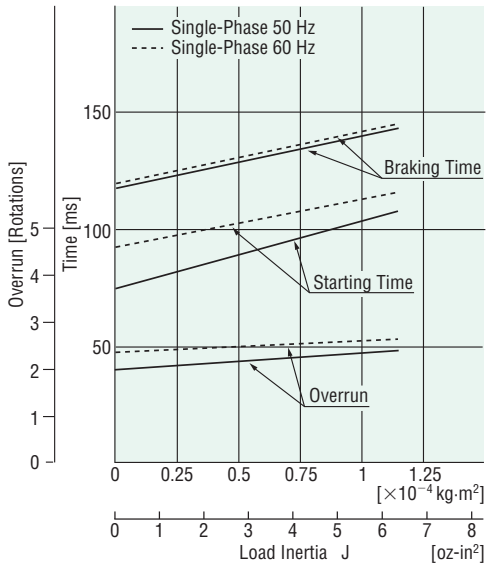

### Three-Phase Motor

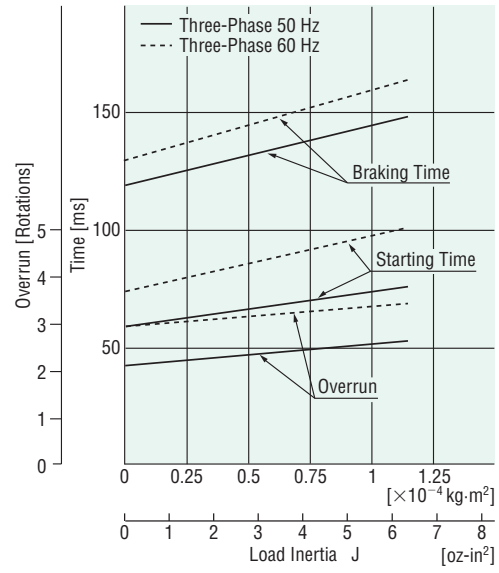

## Dimensions Unit = mm (in.)

● Mounting screws are included with gearheads. Dimensions for mounting screws → Page A-310

### Motor/Gearhead

Mass: Motor 3.4 kg (7.5 lb.)  
Gearhead 1.5 kg (3.3 lb.)

**DXF** A470U

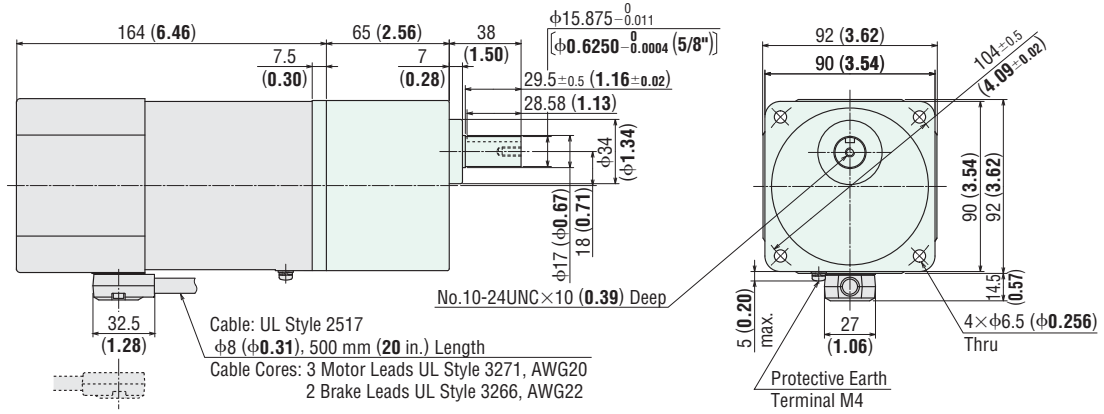

● Cable direction can be switched to the opposite direction.

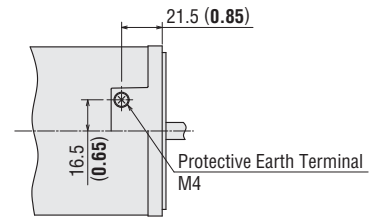

Detail Drawing of Protective Earth Terminal

### Key and Key Slot (The key is included with the gearhead)

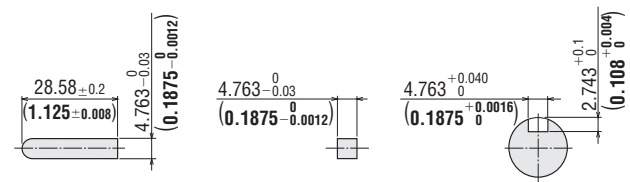

- Introduction
- Induction Motors
- Reversible Motors
- Electro-magnetic Brake Motors
- V Series
- Clutch & Brake Motors
- Synchronous Motors
- Low-Speed Synchronous Motors
- Waterlight, Dust-Resistant Motors
- Torque Motors
- Right-Angle Gearheads
- Linear Heads
- Brake Pack
- Accessories
- Installation

6 W  
(1/125 HP)

15 W  
(1/50 HP)

25 W  
(1/30 HP)

40 W  
(1/19 HP)

60 W  
(1/2 HP)

90 W  
(1/8 HP)

200 W  
(1/4 HP)

◇ Shaft Section of Round Shaft Type

The mass and motor's dimensions (excluding the shaft section) are the same as those of the pinion shaft types.

Mass: 3.4 kg (7.5 lb.)

**DXF** A471

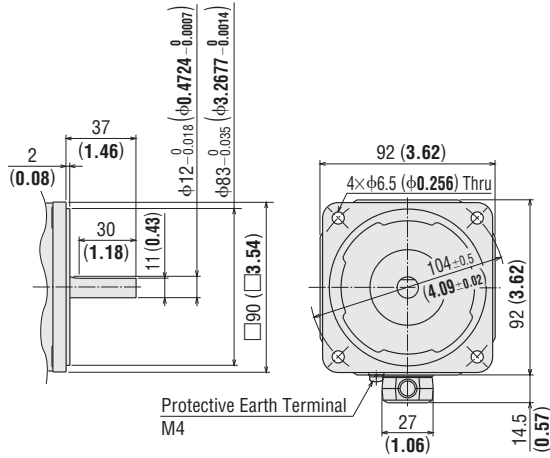

◇ Decimal Gearhead

Can be connected to **GE** pinion shaft type.

**5GE10XS**

Mass: 0.6 kg (1.32 lb.)

**DXF** A029

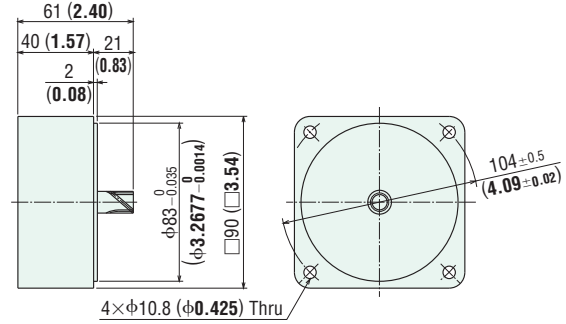

◇ Capacitor

(Included with single-phase motors)

◇ Capacitor Dimensions Unit = mm (in.)

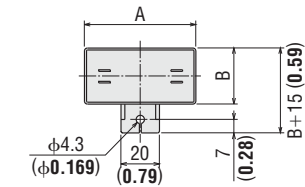

Model		Capacitor Model	A	B	C	Mass g (oz.)	Capacitor Cap
Pinion Shaft Type	Round Shaft Type						
<b>5RK60GE-AW2MU</b>	<b>5RK60A-AW2MU</b>	CH200CFAUL2	58 (2.28)	29 (1.14)	41 (1.61)	91 (3.2)	Included
<b>5RK60GE-CW2ME</b>	<b>5RK60A-CW2ME</b>	CH50BFAUL	58 (2.28)	29 (1.14)	41 (1.61)	93 (3.3)	

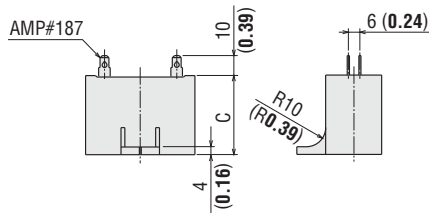

## Connection Diagrams

- The direction of motor rotation is as viewed from the shaft end of the motor. CW represents the clockwise direction, while CCW represents the counterclockwise direction.
- Connection diagrams are also valid for the equivalent round shaft type.

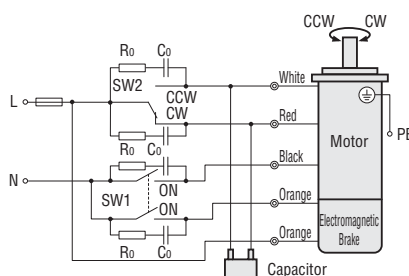
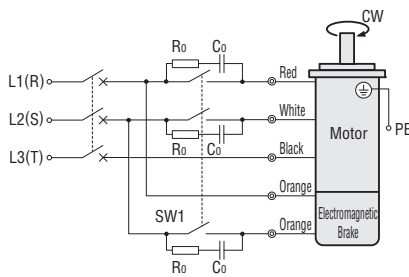
Single-Phase Motor	<p><b>5RK60GE-AW2MU</b> <b>5RK60GE-CW2ME</b></p>	 <p>The diagram shows a single-phase AC motor with an electromagnetic brake. It features two switches, SW1 and SW2, and two capacitors, Co. SW1 is a double-throw switch that controls both the motor and the brake. SW2 is a selector switch for rotation direction, with positions for CCW (counterclockwise) and CW (clockwise). The motor has four main leads: White (positive), Red, Black, and Orange. The brake has two orange leads. A capacitor is connected to the motor's winding. Protective Earth (PE) is also shown.</p>	<p>SW1 operates both motor and electromagnetic brake action. The electromagnetic brake will be released and the motor will rotate when SW1 is switched simultaneously to ON. When SW1 is switched simultaneously to OFF, the motor stops immediately with the electromagnetic brake and holds the load.</p> <p>If you wish to release the brake while the motor is stopped, apply voltage between the two brake lead wires (orange).</p> <p>Rotation Direction To rotate the motor in a clockwise (CW) direction, turn SW2 to CW. To rotate the motor in a counterclockwise (CCW) direction, turn SW2 to CCW.</p> <table border="1"> <thead> <tr> <th rowspan="2">Switch No.</th> <th colspan="2">Specifications</th> <th rowspan="2">Note</th> </tr> <tr> <th>Single-Phase 110/115 VAC Input</th> <th>Single-Phase 220/230 VAC Input</th> </tr> </thead> <tbody> <tr> <td>SW1</td> <td>125 VAC 5 A minimum</td> <td>250 VAC 5 A minimum</td> <td>Switched Simultaneously</td> </tr> <tr> <td>SW2</td> <td>(Inductive Load)</td> <td>(Inductive Load)</td> <td>-</td> </tr> </tbody> </table>	Switch No.	Specifications		Note	Single-Phase 110/115 VAC Input	Single-Phase 220/230 VAC Input	SW1	125 VAC 5 A minimum	250 VAC 5 A minimum	Switched Simultaneously	SW2	(Inductive Load)	(Inductive Load)	-
Switch No.	Specifications		Note														
	Single-Phase 110/115 VAC Input	Single-Phase 220/230 VAC Input															
SW1	125 VAC 5 A minimum	250 VAC 5 A minimum	Switched Simultaneously														
SW2	(Inductive Load)	(Inductive Load)	-														
Three-Phase Motor	<p><b>5IK60GE-SW2M</b></p>	 <p>The diagram shows a three-phase AC motor with an electromagnetic brake. It features a single switch, SW1, and two capacitors, Co. SW1 is a double-throw switch that controls both the motor and the brake. The motor has three main leads: Red, White, and Black. The brake has two orange leads. A capacitor is connected to the motor's winding. Protective Earth (PE) is also shown.</p>	<p>SW1 operates both motor and electromagnetic brake action. The electromagnetic brake will be released and the motor will rotate when SW1 is switched simultaneously to ON. When SW1 is switched simultaneously to OFF, the motor stops immediately with the electromagnetic brake and holds the load.</p> <p>If you wish to release the brake while the motor is stopped, apply voltage between the two brake lead wires (orange).</p> <p>Rotation Direction To change the rotation direction, change any two connections between L1(R), L2(S) and L3(T).</p> <table border="1"> <thead> <tr> <th>Switch No.</th> <th>Specifications</th> <th>Note</th> </tr> </thead> <tbody> <tr> <td>SW1</td> <td>250 VAC 5 A minimum (Inductive Load)</td> <td>Switched Simultaneously</td> </tr> </tbody> </table>	Switch No.	Specifications	Note	SW1	250 VAC 5 A minimum (Inductive Load)	Switched Simultaneously								
Switch No.	Specifications	Note															
SW1	250 VAC 5 A minimum (Inductive Load)	Switched Simultaneously															



PE: Protective Earth

- $R_o$  and  $C_o$  indicate CR circuit for surge suppression. [ $R_o = 5 \sim 200 \Omega$ ,  $C_o = 0.1 \sim 0.2 \mu F$ , 200 WV (400 WV)]

**EPCR1201-2** (CR circuit) is available as an accessory. → Page A-302

- How to connect a capacitor → Page A-313

### Gearhead, Accessories and Peripheral Equipment

<p><b>Space-Saving</b> Right-Angle Gearheads → Page A-239</p> 	<p><b>Instantaneous Stop</b> Brake Pack → Page A-277</p> 	<p><b>Accessories</b> → Page A-287</p> 
-----------------------------------------------------------------------------------------------------------------------------------------------------------	------------------------------------------------------------------------------------------------------------------------------------------------------	--------------------------------------------------------------------------------------------------------------------------------

## Power Off Activated Type Electromagnetic Brake Motors

90 W (1/8 HP)

Frame Size: □90 mm (□3.54 in.)



(Gearhead sold separately)

## Specifications

### ● Motor (RoHS)

● This type of motor does not contain a built-in friction brake mechanism.



Model		Rating	Output Power W HP	Voltage VAC	Frequency Hz	Current A	Starting Torque mN·m oz-in	Rated Torque mN·m oz-in	Rated Speed r/min	Capacitor μF
Pinion Shaft Type	Round Shaft Type									
TP 5RK90GE-AW2MU	5RK90A-AW2MU	30 minutes	90 1/8	Single-Phase 110	60	1.81	590 83	585 83	1500	30
				Single-Phase 115						
TP 5RK90GE-CW2ME	5RK90A-CW2ME	30 minutes	90 1/8	Single-Phase 220	60	0.96	590 83	605 85	1450	7.0
				Single-Phase 230						
						60	0.96	590 83	605 85	
TP 5IK90GE-SW2M	5IK90A-SW2M	Continuous	90 1/8	Three-Phase 200	50	0.64	850 120	680 96	1300	-
					60	0.59	700 99	570 80	1550	
				Three-Phase 220	60	0.60	700 99	570 80	1600	
				Three-Phase 230						

● The **U** and **E** at the end of the model name indicate that the unit includes a capacitor. These letters are not listed on the motor nameplate.  
When the motor is approved under various safety standards, the model name on the nameplate is the approved model name. → Page G-11

● Details of safety standards → Page G-2

● Details of RoHS Directive → Page G-38

TP: Contains a built-in thermal protector (automatic return type). If a motor overheats for any reason, the thermal protector is activated and the motor is stopped.  
(The power supply to the electromagnetic brake is kept and the brake is released.)

When the motor temperature drops, the thermal protector closes and the motor restarts. Be sure to turn the motor power off before inspecting.

### ● Electromagnetic Brake (Power Off Activated Type)

Motor Model	Voltage VAC	Frequency Hz	Current A	Input W	Holding Brake Torque mN·m oz-in	
5RK90GE-AW2MU 5RK90A-AW2MU	Single-Phase 110	60	0.13	10	500	
	Single-Phase 115				71	
5RK90GE-CW2ME 5RK90A-CW2ME	Single-Phase 220	60	0.07	10	500	
	Single-Phase 230				50	71
					60	
5IK90GE-SW2M 5IK90A-SW2M	Single-Phase 200	50	0.07	10	500	
		60				71
	Single-Phase 220	60				
	Single-Phase 230					

## Product Line

### ● Motor (RoHS)

Model	
Pinion Shaft Type	Round Shaft Type
<b>5RK90GE-AW2MU</b>	<b>5RK90A-AW2MU</b>
<b>5RK90GE-CW2ME</b>	<b>5RK90A-CW2ME</b>
<b>5IK90GE-SW2M</b>	<b>5IK90A-SW2M</b>

The following items are included in each product.  
 Motor, Capacitor\*, Capacitor Cap\*, Operating Manual  
 \*Only for single-phase motors

### ● Parallel Shaft Gearhead/Right-Angle Gearhead (Sold separately) (RoHS)

Gearhead Type		Gearhead Model	Gear Ratio
Parallel Shaft	Long Life <b>GE-S</b> Gearhead	<b>5GE□SA</b>	<b>3, 3.6, 5, 6, 7.5, 9, 12.5, 15, 18, 25, 30, 36, 50, 60, 75, 90, 100, 120, 150, 180</b>
	Hollow Shaft	<b>5GE□RH</b>	
Right-Angle Shaft	Solid Shaft	<b>5GE□RAA</b>	
Parallel Shaft	Long Life <b>GE-S</b> Gearhead	<b>5GE10XS</b> (Decimal Gearhead)	

● Enter the gear ratio in the box (□) within the model name.

The following items are included in each product.

- Parallel Shaft Gearhead  
Gearhead, Mounting Screws, Parallel Key, Operating Manual
- Hollow Shaft Gearhead  
Gearhead, Mounting Screws, Parallel Key, Safety Cover (with screws), Gasket, Operating Manual
- Solid Shaft Gearhead  
Gearhead, Mounting Screws, Parallel Key, Gasket, Operating Manual

## Gearmotor – Torque Table

- Gearheads and decimal gearheads are sold separately.
- Enter the gear ratio in the box (□) within the gearhead model name.
- A colored background (□) indicates gear shaft rotation in the same direction as the motor shaft, while the others rotate in the opposite direction.
- The speed is calculated by dividing the motor's synchronous speed (50 Hz: 1500 r/min, 60 Hz: 1800 r/min) by the gear ratio. The actual speed is 2~20% less than the displayed value, depending on the load.
- To reduce the speed beyond the gear ratio in the table, attach a decimal gearhead (gear ratio 10:1) between the gearhead and the motor. In that case, the permissible torque is 20 N·m (177 lb-in).

### ◇ 50 Hz

Unit = Upper values: N·m/Lower values: lb-in

Model Motor/ Gearhead	Speed r/min	500	416	300	250	200	166	120	100	83	60	50	41	30	25	20	16	15	12.5	10	8.3
	Gear Ratio	<b>3</b>	<b>3.6</b>	<b>5</b>	<b>6</b>	<b>7.5</b>	<b>9</b>	<b>12.5</b>	<b>15</b>	<b>18</b>	<b>25</b>	<b>30</b>	<b>36</b>	<b>50</b>	<b>60</b>	<b>75</b>	<b>90</b>	<b>100</b>	<b>120</b>	<b>150</b>	<b>180</b>
<b>5RK90GE-CW2ME</b> / <b>5GE□SA</b>	1.8 15.9	2.1 18.5	3.0 26	3.5 30	4.4 38	5.3 46	6.7 59	8.0 70	9.6 84	12.0 106	14.5 128	17.3 153	20 177	20 177	20 177	20 177	20 177	20 177	20 177	20 177	20 177
<b>5IK90GE-SW2M</b> / <b>5GE□SA</b>	1.7 15.0	2.0 17.7	2.8 24	3.3 29	4.1 36	5.0 44	6.2 54	7.4 65	8.9 78	11.2 99	13.5 119	16.2 143	20 177	20 177	20 177	20 177	20 177	20 177	20 177	20 177	20 177

### ◇ 60 Hz

Unit = Upper values: N·m/Lower values: lb-in

Model Motor/ Gearhead	Speed r/min	600	500	360	300	240	200	144	120	100	72	60	50	36	30	24	20	18	15	12	10
	Gear Ratio	<b>3</b>	<b>3.6</b>	<b>5</b>	<b>6</b>	<b>7.5</b>	<b>9</b>	<b>12.5</b>	<b>15</b>	<b>18</b>	<b>25</b>	<b>30</b>	<b>36</b>	<b>50</b>	<b>60</b>	<b>75</b>	<b>90</b>	<b>100</b>	<b>120</b>	<b>150</b>	<b>180</b>
<b>5RK90GE-AW2MU</b> / <b>5GE□SA</b>	1.4 12.3	1.7 15.0	2.4 21	2.8 24	3.6 31	4.3 38	5.3 46	6.4 56	7.7 68	9.7 85	11.6 102	13.9 123	19.3 170	20 177	20 177	20 177	20 177	20 177	20 177	20 177	20 177
<b>5RK90GE-CW2ME</b> / <b>5GE□SA</b>	1.5 13.2	1.8 15.9	2.5 22	2.9 25	3.7 32	4.4 38	5.5 48	6.6 58	7.9 69	10.0 88	12.0 106	14.4 127	20 177	20 177	20 177	20 177	20 177	20 177	20 177	20 177	20 177
<b>5IK90GE-SW2M</b> / <b>5GE□SA</b>	1.4 12.3	1.7 15.0	2.3 20	2.8 24	3.5 30	4.2 37	5.2 46	6.2 54	7.5 66	9.4 83	11.3 100	13.5 119	18.8 166	20 177	20 177	20 177	20 177	20 177	20 177	20 177	20 177

## Gearmotor – Torque Table When Right-Angle Gearhead is Attached

→ Page A-250

## Permissible Overhung Load and Permissible Thrust Load

Motor (Round shaft type) → Page A-16

Gearhead → Page A-16

## Permissible Load Inertia J of Gearhead

→ Page A-17

## Starting and Braking Characteristics (Reference values)

### Single-Phase Motor

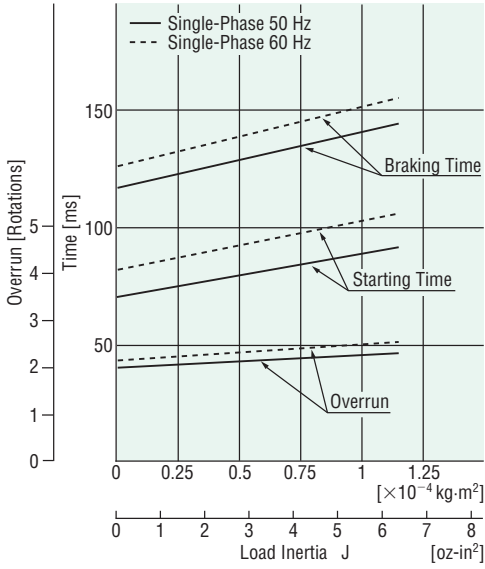

### Three-Phase Motor

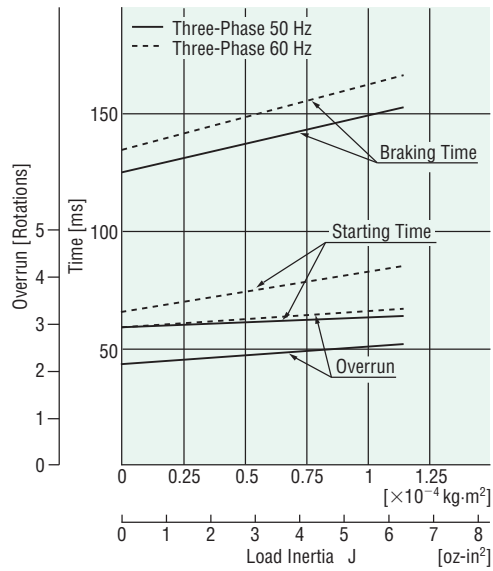

## Dimensions Unit = mm (in.)

● Mounting screws are included with gearheads. Dimensions for mounting screws → Page A-310

### Motor/Gearhead

Mass: Motor 3.9 kg (8.6 lb.)  
Gearhead 1.5 kg (3.3 lb.)

DXF A472U

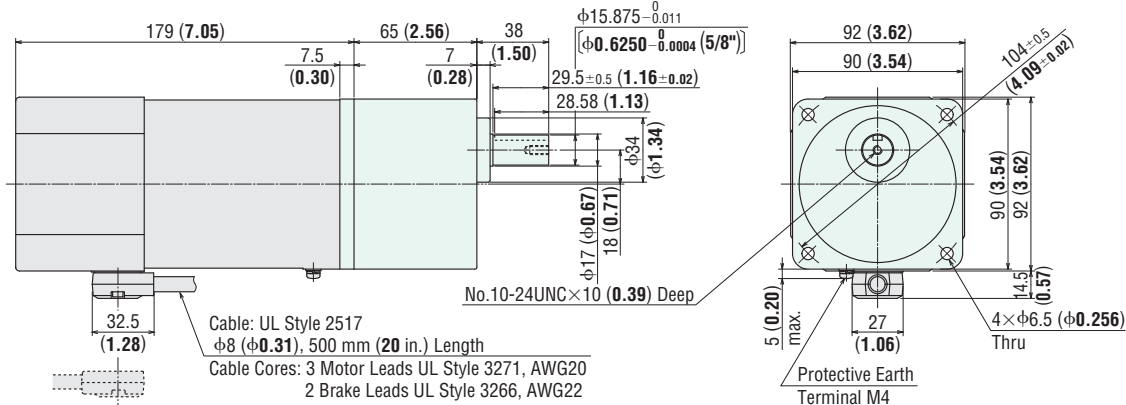

● Cable direction can be switched to the opposite direction.

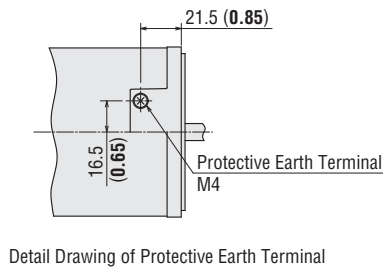

### Key and Key Slot

(The key is included with the gearhead)

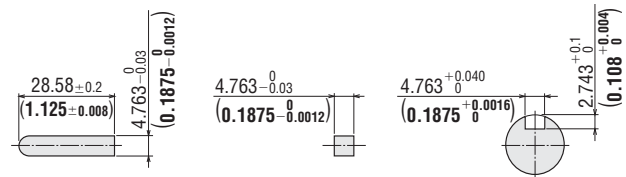



◇ Shaft Section of Round Shaft Type

The mass and motor's dimensions (excluding the shaft section) are the same as those of the pinion shaft types.

Mass: 3.9 kg (8.6 lb.)

**DXF** A473

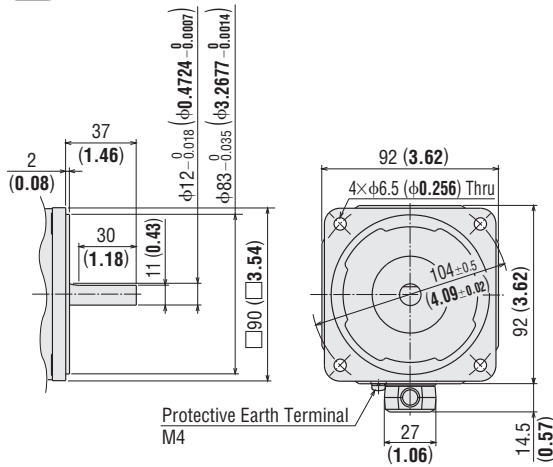

◇ Decimal Gearhead

Can be connected to **GE** pinion shaft type.

**5GE10XS**

Mass: 0.6 kg (1.32 lb.)

**DXF** A029

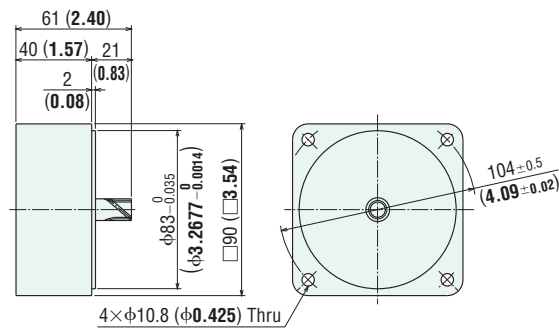

◇ Capacitor

(Included with single-phase motors)

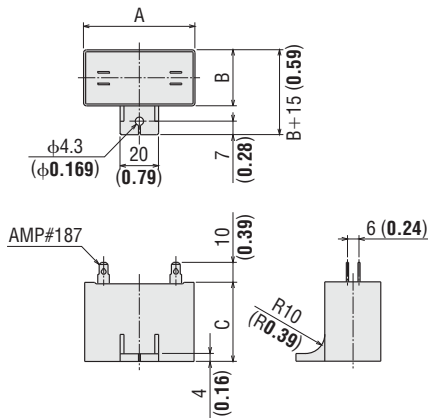

◇ Capacitor Dimensions Unit = mm (in.)

Model		Capacitor Model	A	B	C	Mass g (oz.)	Capacitor Cap
Pinion Shaft Type	Round Shaft Type						
<b>5RK90GE-AW2MU</b>	<b>5RK90A-AW2MU</b>	CH300CFAUL2	58 (2.28)	35 (1.38)	50 (1.97)	140 (4.9)	Included
<b>5RK90GE-CW2ME</b>	<b>5RK90A-CW2ME</b>	CH70BFAUL	58 (2.28)	35 (1.38)	50 (1.97)	138 (4.9)	

- Introduction
- Induction Motors
- Reversible Motors
- Electro-magnetic Brake Motors
- V Series
- Clutch & Brake Motors
- Synchronous Motors
- Low-Speed Synchronous Motors
- Waterlight-Dust-Resistant Motors
- Torque Motors
- Right-Angle Gearheads
- Linear Heads
- Brake Pack
- Accessories
- Installation

## Connection Diagrams

- The direction of motor rotation is as viewed from the shaft end of the motor. CW represents the clockwise direction, while CCW represents the counterclockwise direction.
- Connection diagrams are also valid for the equivalent round shaft type.

<p>Single-Phase Motor</p>	<p><b>5RK90GE-AW2MU</b> <b>5RK90GE-CW2ME</b></p>		<p>SW1 operates both motor and electromagnetic brake action. The electromagnetic brake will be released and the motor will rotate when SW1 is switched simultaneously to ON. When SW1 is switched simultaneously to OFF, the motor stops immediately with the electromagnetic brake and holds the load.</p> <p>If you wish to release the brake while the motor is stopped, apply voltage between the two brake lead wires (orange).</p> <p><b>Rotation Direction</b> To rotate the motor in a clockwise (CW) direction, turn SW2 to CW. To rotate the motor in a counterclockwise (CCW) direction, turn SW2 to CCW.</p> <table border="1"> <thead> <tr> <th rowspan="2">Switch No.</th> <th colspan="2">Specifications</th> <th rowspan="2">Note</th> </tr> <tr> <th>Single-Phase 110/115 VAC Input</th> <th>Single-Phase 220/230 VAC Input</th> </tr> </thead> <tbody> <tr> <td>SW1</td> <td>125 VAC 5 A minimum (Inductive Load)</td> <td>250 VAC 5 A minimum (Inductive Load)</td> <td>Switched Simultaneously</td> </tr> <tr> <td>SW2</td> <td></td> <td></td> <td>—</td> </tr> </tbody> </table>	Switch No.	Specifications		Note	Single-Phase 110/115 VAC Input	Single-Phase 220/230 VAC Input	SW1	125 VAC 5 A minimum (Inductive Load)	250 VAC 5 A minimum (Inductive Load)	Switched Simultaneously	SW2			—
Switch No.	Specifications		Note														
	Single-Phase 110/115 VAC Input	Single-Phase 220/230 VAC Input															
SW1	125 VAC 5 A minimum (Inductive Load)	250 VAC 5 A minimum (Inductive Load)	Switched Simultaneously														
SW2			—														
<p>Three-Phase Motor</p>	<p><b>5IK90GE-SW2M</b></p>		<p>SW1 operates both motor and electromagnetic brake action. The electromagnetic brake will be released and the motor will rotate when SW1 is switched simultaneously to ON. When SW1 is switched simultaneously to OFF, the motor stops immediately with the electromagnetic brake and holds the load.</p> <p>If you wish to release the brake while the motor is stopped, apply voltage between the two brake lead wires (orange).</p> <p><b>Rotation Direction</b> To change the rotation direction, change any two connections between L1(R), L2(S) and L3(T).</p> <table border="1"> <thead> <tr> <th>Switch No.</th> <th>Specifications</th> <th>Note</th> </tr> </thead> <tbody> <tr> <td>SW1</td> <td>250 VAC 5 A minimum (Inductive Load)</td> <td>Switched Simultaneously</td> </tr> </tbody> </table>	Switch No.	Specifications	Note	SW1	250 VAC 5 A minimum (Inductive Load)	Switched Simultaneously								
Switch No.	Specifications	Note															
SW1	250 VAC 5 A minimum (Inductive Load)	Switched Simultaneously															

PE: Protective Earth

●  $R_o$  and  $C_o$  indicate CR circuit for surge suppression. [ $R_o = 5 \sim 200 \Omega$ ,  $C_o = 0.1 \sim 0.2 \mu\text{F}$ , 200 WV (400 WV)]

● **EPCR1201-2** (CR circuit) is available as an accessory. → Page A-302

● How to connect a capacitor → Page A-313

### Gearhead, Accessories and Peripheral Equipment

<p><b>Space-Saving Right-Angle Gearheads</b> → Page A-239</p> 	<p><b>Instantaneous Stop Brake Pack</b> → Page A-277</p> 	<p><b>Accessories</b> → Page A-287</p> 
-------------------------------------------------------------------------------------------------------------------------------------------------------	--------------------------------------------------------------------------------------------------------------------------------------------------	--------------------------------------------------------------------------------------------------------------------------------

# Induction Motors BH Series

## Power Off Activated Electromagnetic Brake

### 200 W (1/4 HP)

Frame Size: □104 mm (□4.09 in.)

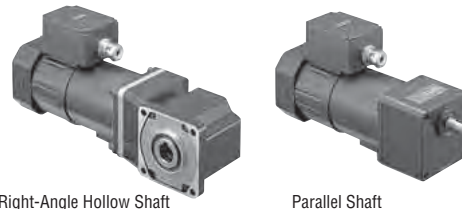

Right-Angle Hollow Shaft

Parallel Shaft

### Features

● **High Power 200 W (1/4 HP)**

Smallest frame size among 200 W (1/4 HP) motors

● **Hypoid Gear-Employed Right-Angle Gearheads**

Right-angle gearheads employ hypoid gears. Hollow shafts and solid shafts are available to enable space-saving.

● **RoHS Compliant**

The BH Series conforms to the RoHS Directive that prohibits the use of six chemical substances including lead and cadmium.

● Details of RoHS Directive → Page G-38

● **"Combination Type" for Easy Installation**

The combination type comes with the motor and gearhead pre-assembled. This enables easy installation in equipment.

Combination Type:

The combination type comes with the motor and its dedicated gearhead pre-assembled, which simplifies installation in equipment. Motors and gearheads are also available separately to facilitate changes or repairs.

### Specifications – Continuous Rating (RoHS)



Model		Output Power	Voltage	Frequency	Current	Starting Torque	Rated Torque	Rated Speed	Capacitor
Combination Type	Round Shaft Type	W HP	VAC	Hz	A	N-m oz-in	N-m oz-in	r/min	μF
Ⓣ <b>BHI62FMT-□RH</b> <b>BHI62FMT-□RA</b> <b>BHI62FMT-□</b>	<b>BHI62FMT-A</b>	200 1/4	Single-Phase 110	60	3	0.88 124	1.27 180	1500	40
			Single-Phase 115			0.98 139			
Ⓣ <b>BHI62EMT-□RH</b> <b>BHI62EMT-□RA</b> <b>BHI62EMT-□</b>	<b>BHI62EMT-A</b>	200 1/4	Single-Phase 220	60	1.5	0.98 139	1.27 180	1500	10
			Single-Phase 230	50	1.5	0.98 139	1.52 210	1250	10
				60			1.27 180	1500	
			Ⓣ <b>BHI62SMT-□RH</b> <b>BHI62SMT-□RA</b> <b>BHI62SMT-□</b>	<b>BHI62SMT-A</b>	200 1/4	Three-Phase 200	50	1.1	1.49 210
60	1.25 177	1.25 177					1500		
Three-Phase 220	60	0.95				1.23 174	1.23 174	1550	-
Three-Phase 230	60		1.18 167	1.18 167	1600				

● Enter the gear ratio in the box (□) within the model name. The values for each specification applies to the motor only.

● Details of safety standards → Page G-2

● List of safety standard approved products (Model, Standards, Standards File No., Certification Body) → Page G-11

Ⓣ: Contains a built-in thermal protector (automatic return type). If a motor overheats for any reason, the thermal protector is activated and the motor is stopped. (The power supply to the electromagnetic brake is kept and the brake is released.)

When the motor temperature drops, the thermal protector closes and the motor restarts. Be sure to turn the motor power off before inspecting.

● **Electromagnetic Brake (Power Off Activated Type)**

Motor Model	Voltage	Frequency	Current	Input	Holding Brake Torque
	VAC	Hz	A	W	N-m oz-in
<b>BHI62FMT-□RH, BHI62FMT-□RA</b> <b>BHI62FMT-□, BHI62FMT-A</b>	Single-Phase 110	60	0.17	12	1.5
	Single-Phase 115				210
<b>BHI62EMT-□RH, BHI62EMT-□RA</b> <b>BHI62EMT-□, BHI62EMT-A</b>	Single-Phase 220	60	0.09	12	1.5 210
	Single-Phase 230	50	0.09	12	1.5
		60			210
	<b>BHI62SMT-□RH, BHI62SMT-□RA</b> <b>BHI62SMT-□, BHI62SMT-A</b>	Single-Phase 200	50	0.09	12
60			210		
Single-Phase 220		60	0.09	12	1.5
Single-Phase 230	60	210			

● Enter the gear ratio in the box (□) within the model name.

## Product Line

### ● Combination Type (RoHS)

#### ◇ Right-Angle Shaft

Type	Voltage	Model	Gear Ratio
Hollow Shaft	Single-Phase 110/115 VAC	<b>BHI62FMT-□RH</b>	<b>5, 6, 7.5, 9, 12.5, 15, 18, 25, 30, 36, 50, 60, 75, 90, 100, 120, 150, 180</b>
	Single-Phase 220/230 VAC	<b>BHI62EMT-□RH</b>	
	Three-Phase 200/220/230 VAC	<b>BHI62SMT-□RH</b>	
Solid Shaft	Single-Phase 110/115 VAC	<b>BHI62FMT-□RA</b>	
	Single-Phase 220/230 VAC	<b>BHI62EMT-□RA</b>	
	Three-Phase 200/220/230 VAC	<b>BHI62SMT-□RA</b>	

● Enter the gear ratio in the box (□) within the model name.

— The following items are included in each product. —  
 Motor, Gearhead, Capacitor\*, Capacitor Cap\*, Parallel Key, Operating Manual  
 \* Only for single-phase motors

#### ◇ Parallel Shaft

Voltage	Model	Gear Ratio
Single-Phase 110/115 VAC	<b>BHI62FMT-□</b>	<b>3, 3.6, 5, 6, 7.5, 9, 12.5, 15, 18, 25, 30, 36, 50, 60, 75, 90, 100, 120, 150, 180</b>
Single-Phase 220/230 VAC	<b>BHI62EMT-□</b>	
Three-Phase 200/220/230 VAC	<b>BHI62SMT-□</b>	

● Enter the gear ratio in the box (□) within the model name.

— The following items are included in each product. —  
 Motor, Gearhead, Capacitor\*, Capacitor Cap\*, Mounting Screws, Parallel Key,  
 Operating Manual  
 \* Only for single-phase motors

### ● Round Shaft Type (RoHS)

Voltage	Model
Single-Phase 110/115 VAC	<b>BHI62FMT-A</b>
Single-Phase 220/230 VAC	<b>BHI62EMT-A</b>
Three-Phase 200/220/230 VAC	<b>BHI62SMT-A</b>

— The following items are included in each product. —  
 Motor, Capacitor\*, Capacitor Cap\*, Operating Manual  
 \* Only for single-phase motors

## Gearmotor – Torque Table for Combination Type

- Enter the gear ratio in the box (□) within the model name.
- A colored background ( ) indicates gear shaft rotation in the same direction as the motor shaft, while the others rotate in the opposite direction. The directions will be reversed for all right-angle shaft types.
- The speed is calculated by dividing the motor's synchronous speed (50 Hz: 1500 r/min, 60 Hz: 1800 r/min) by the gear ratio.  
The actual speed is 2~20% less than the displayed value, depending on the load.
- Decimal gearheads are not available for the **BH** Series.

### ● Right-Angle Shaft 50 Hz

Unit = Upper values: N-m/Lower values: lb-in

Model	Speed r/min	300	250	200	167	120	100	83	60	50	42	30	25	20	17	15	12.5	10	8.3
	Gear Ratio	<b>5</b>	<b>6</b>	<b>7.5</b>	<b>9</b>	<b>12.5</b>	<b>15</b>	<b>18</b>	<b>25</b>	<b>30</b>	<b>36</b>	<b>50</b>	<b>60</b>	<b>75</b>	<b>90</b>	<b>100</b>	<b>120</b>	<b>150</b>	<b>180</b>
<b>BHI62EMT-□RH/RA</b>	5.5	6.7	8.3	10.0	13.9	16.6	20.0	27.7	33.3	36.0	40.0	43.0	47.0	51.5	54.5	60	60	60	60
	48	59	73	88	123	146	177	240	290	310	350	380	410	450	480	530	530	530	530
<b>BHI62SMT-□RH/RA</b>	5.4	6.5	8.2	9.8	13.6	16.3	19.6	27.2	32.6	36.0	40.0	43.0	47.0	51.5	54.5	60	60	60	60
	47	57	72	86	120	144	173	240	280	310	350	380	410	450	480	530	530	530	530

### ● Right-Angle Shaft 60 Hz

Unit = Upper values: N-m/Lower values: lb-in

Model	Speed r/min	360	300	240	200	144	120	100	72	60	50	36	30	24	20	18	15	12	10
	Gear Ratio	<b>5</b>	<b>6</b>	<b>7.5</b>	<b>9</b>	<b>12.5</b>	<b>15</b>	<b>18</b>	<b>25</b>	<b>30</b>	<b>36</b>	<b>50</b>	<b>60</b>	<b>75</b>	<b>90</b>	<b>100</b>	<b>120</b>	<b>150</b>	<b>180</b>
<b>BHI62FMT-□RH/RA</b> <b>BHI62EMT-□RH/RA</b>	4.6	5.6	7.0	8.3	11.6	13.9	16.7	23.2	27.8	33.4	40.0	43.0	47.0	51.5	54.5	60	60	60	60
	40	49	61	73	102	123	147	200	240	290	350	380	410	450	480	530	530	530	530
<b>BHI62SMT-□RH/RA (200 VAC)</b>	4.6	5.5	6.8	8.2	11.4	13.7	16.4	22.8	27.4	32.9	40.0	43.0	47.0	51.5	54.5	60	60	60	60
	40	48	60	72	100	121	145	200	240	290	350	380	410	450	480	530	530	530	530
<b>BHI62SMT-□RH/RA (220 VAC)</b>	4.5	5.4	6.7	8.1	11.2	13.5	16.2	22.4	26.9	32.3	40.0	43.0	47.0	51.5	54.5	60	60	60	60
	39	47	59	71	99	119	143	198	230	280	350	380	410	450	480	530	530	530	530
<b>BHI62SMT-□RH/RA (230 VAC)</b>	4.3	5.2	6.5	7.8	10.8	12.9	15.5	21.5	25.8	31.0	40.0	43.0	47.0	51.5	54.5	60	60	60	60
	38	46	57	69	95	114	137	190	220	270	350	380	410	450	480	530	530	530	530

● Parallel Shaft 50 Hz

Unit = Upper values: N-m/Lower values: lb-in

Model	Speed r/min	500	417	300	250	200	167	120	100	83	60	50	42	30	25	20	17	15	12.5	10	8.3
	Gear Ratio	3	3.6	5	6	7.5	9	12.5	15	18	25	30	36	50	60	75	90	100	120	150	180
BHI62EMT-□		4.1 36	4.9 43	6.8 60	8.2 72	10.3 91	12.3 108	16.3 144	19.6 173	23.5 200	32.7 280	39.2 340	40 350	40 350	40 350	40 350	40 350	40 350	40 350	40 350	40 350
BHI62SMT-□		4.0 35	4.8 42	6.7 59	8.0 70	10.1 89	12.1 107	16.0 141	19.2 169	23.1 200	32.0 280	38.4 330	40 350	40 350	40 350	40 350	40 350	40 350	40 350	40 350	40 350

● Parallel Shaft 60 Hz

Unit = Upper values: N-m/Lower values: lb-in

Model	Speed r/min	600	500	360	300	240	200	144	120	100	72	60	50	36	30	24	20	18	15	12	10
	Gear Ratio	3	3.6	5	6	7.5	9	12.5	15	18	25	30	36	50	60	75	90	100	120	150	180
BHI62FMT-□		3.4 30	4.1 36	5.7 50	6.9 61	8.6 76	10.3 91	13.7 121	16.4 145	19.7 174	27.3 240	32.8 290	39.3 340	40 350	40 350	40 350	40 350	40 350	40 350	40 350	40 350
BHI62EMT-□		3.4 30	4.1 36	5.6 49	6.8 60	8.4 74	10.1 89	13.4 118	16.1 142	19.4 171	26.9 230	32.3 280	38.7 340	40 350	40 350	40 350	40 350	40 350	40 350	40 350	40 350
BHI62SMT-□ (200 VAC)		3.4 30	4.1 36	5.6 49	6.8 60	8.4 74	10.1 89	13.4 118	16.1 142	19.4 171	26.9 230	32.3 280	38.7 340	40 350	40 350	40 350	40 350	40 350	40 350	40 350	40 350
BHI62SMT-□ (220 VAC)		3.3 29	4.0 35	5.5 48	6.6 58	8.3 73	10.0 88	13.2 116	15.9 140	19.0 168	26.4 230	31.7 280	38.1 330	40 350	40 350	40 350	40 350	40 350	40 350	40 350	40 350
BHI62SMT-□ (230 VAC)		3.2 28	3.8 33	5.3 46	6.4 56	8.0 70	9.6 84	12.7 112	15.2 134	18.3 161	25.4 220	30.4 260	36.5 320	40 350	40 350	40 350	40 350	40 350	40 350	40 350	40 350

■ Permissible Overhung Load and Permissible Thrust Load

Combination Type → Page A-16

Round Shaft Type → Page A-16

■ Permissible Load Inertia J of Gearhead

→ Page A-17

■ Starting and Braking Characteristics (Reference values)

● Single-Phase Motor

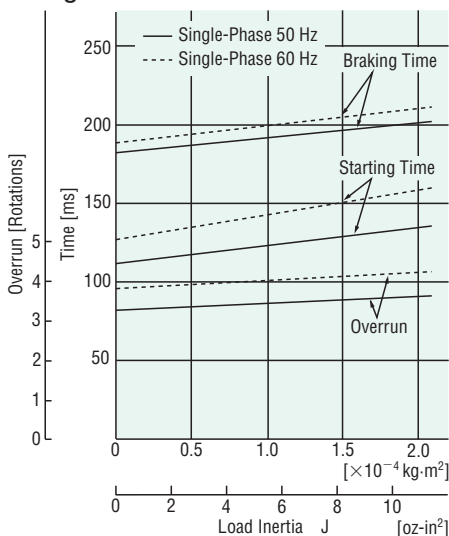

● Three-Phase Motor

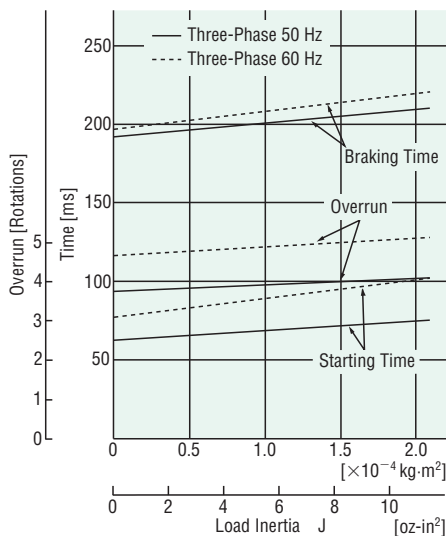



◇ Combination Type: Right-Angle, Solid Shaft

**BHI62FMT-□RA, BHI62EMT-□RA, BHI62SMT-□RA**

Mass: 11.5 kg (25 lb.)

Motor: BHI62FMT-G2, BHI62EMT-G2, BHI62SMT-G2

Gearhead: BH6G2-□RA

**DXF** A385

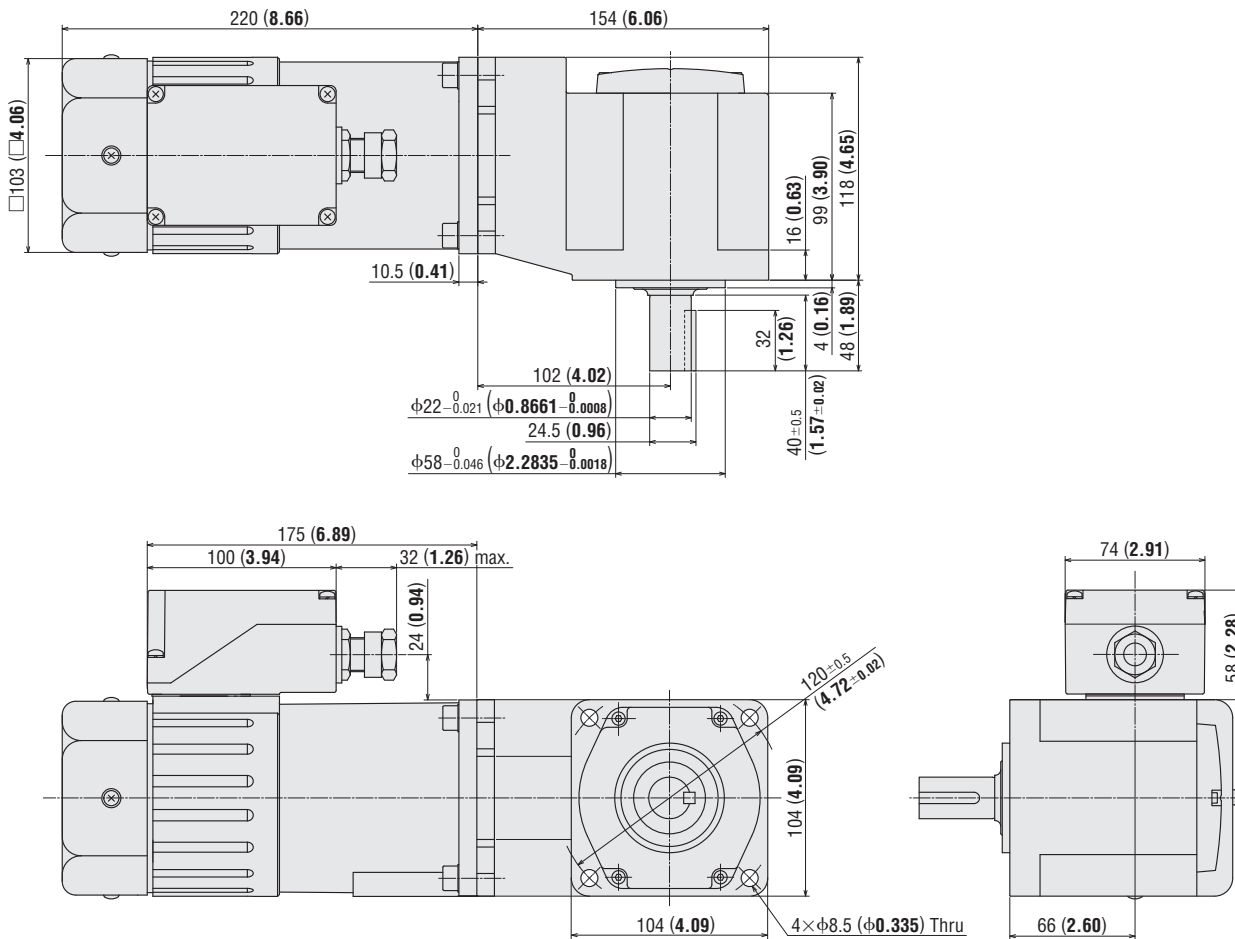

● Use cable with a diameter of  $\phi 8 \sim \phi 12$  mm ( $\phi 0.31 \sim \phi 0.47$  in.).

● Details of terminal box → Page A-314

◇ Key and Key Slot

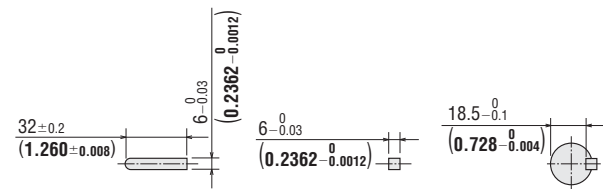

● At the shipment, a parallel key is inserted on the gearhead's shaft.

● Enter the gear ratio in the box (□) within the model name.

◇ Combination Type: Parallel Shaft

**BHI62FMT-□, BHI62EMT-□, BHI62SMT-□**

Mass: 9.5 kg (21 lb.)

Motor: BHI62FMT-G2, BHI62EMT-G2, BHI62SMT-G2

Gearhead: BH6G2-□

**DXF** A386

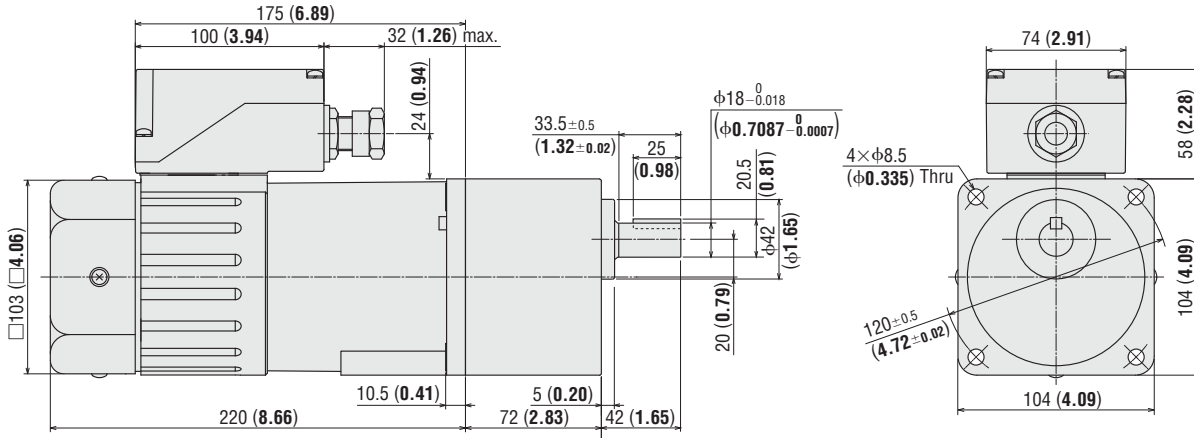

- Use cable with a diameter of  $\phi 8 \sim \phi 12$  mm ( $\phi 0.31 \sim \phi 0.47$  in.).
- Details of terminal box → Page A-314

◇ Key and Key Slot

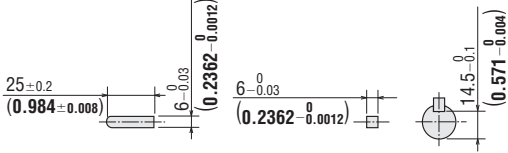

- At the shipment, a parallel key is inserted on the gearhead's shaft.

◇ Round Shaft Type

**BHI62FMT-A, BHI62EMT-A, BHI62SMT-A**

Mass: 6.5 kg (14 lb.)

**DXF** A387

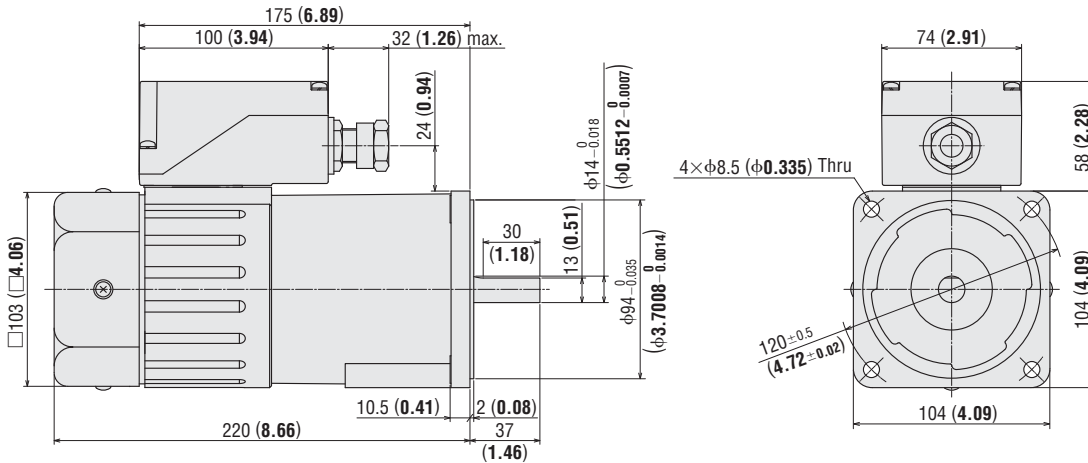

- Use cable with a diameter of  $\phi 8 \sim \phi 12$  mm ( $\phi 0.31 \sim \phi 0.47$  in.).
- Details of terminal box → Page A-314

- Enter the gear ratio in the box (□) within the model name.



◇ Capacitor (Included with single-phase motors)

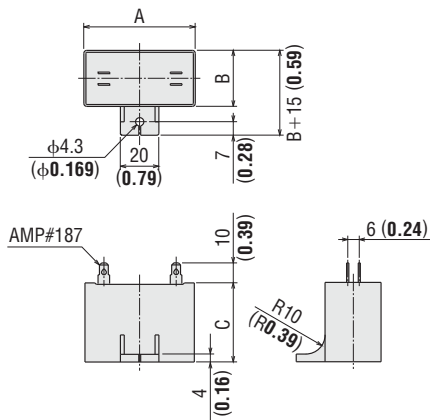

◇ Capacitor Dimensions Unit = mm (in.)

Model	Capacitor Model	A	B	C	Mass g (oz.)	Capacitor Cap
<b>BHI62FMT-□RH</b> <b>BHI62FMT-□RA</b> <b>BHI62FMT-□</b> <b>BHI62FMT-A</b>	CH400CFAUL2	58 (2.28)	41 (1.61)	58 (2.28)	175 (6.2)	Included
<b>BHI62EMT-□RH</b> <b>BHI62EMT-□RA</b> <b>BHI62EMT-□</b> <b>BHI62EMT-A</b>	CH100BFAUL	58 (2.28)	35 (1.38)	50 (1.97)	132 (4.7)	

● Enter the gear ratio in the box (□) within the model name.

■ Mounting Method for Right-Angle, Hollow Shaft Type

These figures below show how to mount loads depending on the shape of the shaft. The tolerance of the inner diameter for the hollow shaft is finished as shown in the table on the right, and "key slot" processing is given to mount the load shaft. Use the key provided with the product by fastening it to the shaft. Apply a coating of molybdenum disulfide or similar grease to the surface of the load shaft and to the inner diameter of the load shaft to prevent sticking. Recommended load shaft diameter and inner diameter of hollow shaft are shown in the table on the right.

● Inner Diameter of Hollow Shaft and Recommended Load Shaft Diameter

Unit = mm (in.)

Model	BH6G2-□RH
Inner Diameter of Hollow Shaft H8	$\phi 25^{+0.033}_0$ (0.9843 <sup>+0.0013</sup> <sub>0</sub> )
Recommended Load Shaft Diameter h7	$\phi 25^{0}_{-0.021}$ (0.9843 <sup>0</sup> <sub>0.0008</sub> )

● Enter the gear ratio in the box (□) within the model name.

● Stepped Load Shaft

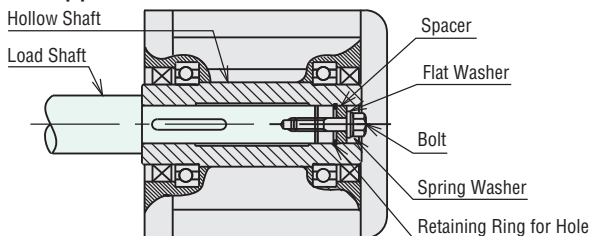

● After securing a load, attach the safety cover included.

Notes:

- Be careful not to apply a shock to the hollow shaft when mounting a load shaft. It may damage the bearing inside the gearhead.
- Bolts or other fasteners used to install the load shaft are not included. These parts must be purchased separately.

● Straight Load Shaft

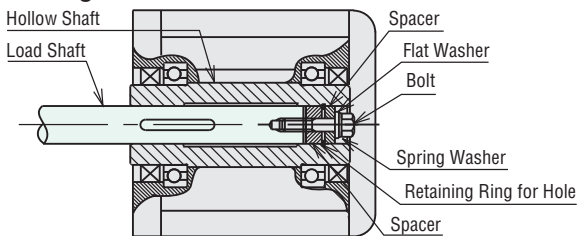

## Connection Diagrams

- The direction of motor rotation is as viewed from the shaft end of the motor. CW indicates clockwise direction, while CCW counterclockwise direction.
- Enter the voltage (**F**, **E** or **S**) in the box (□) within the model name.

Motor Type	Single-Phase Motor	Three-Phase Motor
<ul style="list-style-type: none"> <li>Combination Type: Parallel Shaft <b>BHI62□MT-3~9</b> <b>BHI62□MT-50~180</b></li> <li>Round Shaft Type <b>BHI62□MT-A</b></li> </ul>		<p><b>Clockwise</b></p>
<ul style="list-style-type: none"> <li>Combination Type: Parallel Shaft <b>BHI62□MT-12.5~36</b></li> <li>Combination Type: Right Angle Shaft <b>BHI62□MT-5~180RA</b> <b>BHI62□MT-5~180RH</b></li> </ul>		<p><b>Clockwise</b></p>
Rotation Direction	<p>Clockwise: To rotate in a clockwise (CW) direction, turn SW2 to CW.</p> <p>Counterclockwise: To rotate in a counterclockwise (CCW) direction, turn SW2 to CCW.</p>	To change the rotation direction, change any two connections between R, S and T.

PE: Protective Earth

SW1 operates both motor and electromagnetic brake action.

The electromagnetic brake will be released and the motor will rotate when SW1 is switched simultaneously to ON.

When SW1 is switched simultaneously to OFF, the motor stops immediately with the electromagnetic brake and holds the load.

Switch No.	Specifications			Note
	Single-Phase 110/115 VAC Input	Single-Phase 220/230 VAC Input	Three-Phase 200/220/230 VAC Input	
SW1	125 VAC 5 A minimum	250 VAC 5 A minimum	250 VAC 5 A minimum (Inductive Load)	Switched Simultaneously
SW2	(Inductive Load)	(Inductive Load)	-	-

Connect a CR circuit (R<sub>0</sub> C<sub>0</sub>) for surge suppression shown on the diagrams to protect the contact.

R<sub>0</sub>=5~200 Ω C<sub>0</sub>=0.1~0.2 μF 200 WV

**EPCR1201-2** (CR circuit) is available as an accessory.

**Note:**

- Change the direction of single-phase motor rotation only after bringing the motor to a stop. If an attempt is made to change the direction of rotation while the motor is rotating, motor may ignore reversing command or change its direction of rotation after some delay.

- How to connect a capacitor → Page A-313

## List of Motor and Gearhead Combinations

Motor and gearhead combinations are shown below.

### ● Combination Type: Right Angle Shaft

Model	Motor Model	Gearhead Model
<b>BHI62FMT-□RH</b>	BHI62FMT-G2	BH6G2-□RH
<b>BHI62FMT-□RA</b>		BH6G2-□RA
<b>BHI62EMT-□RH</b>	BHI62EMT-G2	BH6G2-□RH
<b>BHI62EMT-□RA</b>		BH6G2-□RA
<b>BHI62SMT-□RH</b>	BHI62SMT-G2	BH6G2-□RH
<b>BHI62SMT-□RA</b>		BH6G2-□RA

● Enter the gear ratio in the box (□) within the model name.

### ● Combination Type: Parallel Shaft

Model	Motor Model	Gearhead Model
<b>BHI62FMT-□</b>	BHI62FMT-G2	BH6G2-□
<b>BHI62EMT-□</b>	BHI62EMT-G2	
<b>BHI62SMT-□</b>	BHI62SMT-G2	

● Enter the gear ratio in the box (□) within the model name.

### Accessories

Accessories

→ Page A-287



Introduction

Induction Motors

Reversible Motors

Electro-magnetic Brake Motors

V Series

Clutch & Brake Motors

Synchronous Motors

Low-Speed Synchronous Motors

Watertight, Dust-Resistant Motors

Torque Motors

Right-Angle Gearheads

Linear Heads

Brake Pack

Accessories

Installation

