

Standard AC Motors

Brake Pack

Overview, Product Series

Constant Speed Motors

Three-Phase Induction Motors

Single-Phase Induction Motors

Reversible Motors

Electromagnetic Brake Motors

Clutch & Brake Motors

Low-Speed Synchronous Motors

Torque Motors

Watertight, Dust-Resistant Motors

Right-Angle Gearheads

Linear Heads

Brake Pack

Brake Pack

Accessories

Installation

Brake Pack SB50W

For details on this product please refer to our website.

www.orientalmotor.com/catalog



For detailed information about regulations and standards, please see the Oriental Motor website.



View Expanded Product Information, Specifications, CAD, Accessories & more online. Visit www.orientalmotor.com/catalog or use the QR code and select "SB50W".

- Instantaneous stop, bi-directional operation and electromagnetic brake control functions are all possible with a single unit.
- This brake pack can sense when the thermal protector is opened, increasing the safety of your equipment.
- The alarm can be reset with external signals.

Features

● Four Functions in One Integrated Unit

The **SB50W** provides instantaneous stop, bi-directional operation, electromagnetic brake control and thermal protector open detection functions*.

*Thermal protector open detection function

(Available only when combined with a motor having a built-in thermal protector)

When the motor's thermal protector (overheat protection device) is activated, the **SB50W** outputs an alarm signal and automatically cuts the power supply to the motor. The motor will not restart by itself, even after the temperature drops and the thermal protector closes. The alarm can be reset with external signals.

● Wide Voltage Range of 100 to 230 VAC

The **SB50W** covers a single-phase voltage range of 100 to 230 VAC $\pm 10\%$, accommodating major voltages used throughout the world. Use this product according to the power supply voltage of applicable motors.

● Conforms to Standards

The **SB50W** is recognized by UL and CSA, and the CE Marking is used in accordance with the EMC Directive and Low Voltage Directive.

● Supports Motors with 1 W to 90 W (1/750 HP to 1/8 HP) Output

The **SB50W** can be used with induction motors, reversible motors, electromagnetic brake motors and watertight, dust-resistant motors with an output power of 1 W to 90 W (1/750 HP to 1/8 HP).

● Switchable Sink/Source Logic

Select sink logic or source logic for the input/output circuit. You can change the setting at any time.

● Instantaneous Stop

The electronic brake stops the motor instantaneously. A large braking force causes the motor to stop in approximately 0.1 second, allowing for an overrun of 1 to 1.5 rotations. The braking current flows through the motor for approximately 0.4 seconds, after which the power supply to the motor is cut off automatically (The motor will have no holding torque).

● Long Life, Simple Wiring

The electronic brake operates on current flow, so it lasts longer than the mechanically operated electromagnetic brake that is subject to wear. This makes the **SB50W** ideal for indexing applications. The electronic-input type brake pack doesn't use a power relay, so the frequency of maintenance can be reduced. Wiring is easy as well.

● Link Electronic Brake and Electromagnetic Brake

By combining the **SB50W** with a motor equipped with an electromagnetic brake, you can link the electronic brake with the electromagnetic brake to allow the load to be held automatically following an instantaneous stop. This configuration is ideal for vertical applications in which the load must be held following the instantaneous stop of the motor.

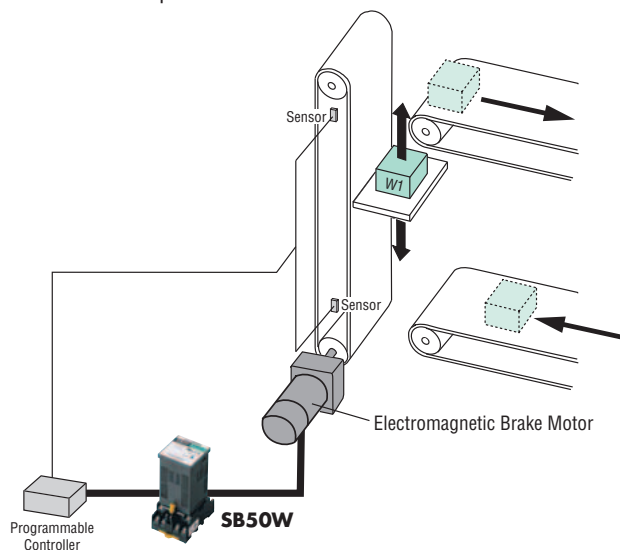

Characteristics of the Brake Pack

How to Read Braking Characteristics (Reference values)

The brake pack provides stable braking characteristics for the instantaneous stop of the motor. The braking characteristics are illustrated by the braking curve, which indicates the amount of overrun corresponding to the inertia.

The braking time is $4n/f$ seconds or less.

Where, n : overrun, f : power supply frequency.

For example, if the Induction Motor 25 W [single-phase 115 VAC, 25 W (1/30 HP)] and **SB50W** are used together to stop a load with an inertia of $J = 0.25 \times 10^{-4} \text{ kg}\cdot\text{m}^2$ (1.37 oz-in²), the overrun and braking time required will be approximately 1.4 rotations and 0.1 seconds, respectively, at a power supply frequency of 60 Hz. In the case of deceleration using a gearhead, refer to the braking characteristics curve after converting the load inertia at the gearhead shaft to its corresponding value at the motor shaft.

Use the following formula to convert the load inertia at the gearhead shaft to its corresponding value at the motor shaft:

$$J_M = \frac{J_G}{i^2} [\text{kg}\cdot\text{m}^2]$$

J_M : Inertia converted to corresponding value at the motor shaft

J_G : Inertia at the gearhead shaft

i : Gear ratio of gearhead

Example of Braking Characteristics with Brake Pack

Brake Pack: **SB50W**

Motor: Induction Motor 25 W (1/30 HP)

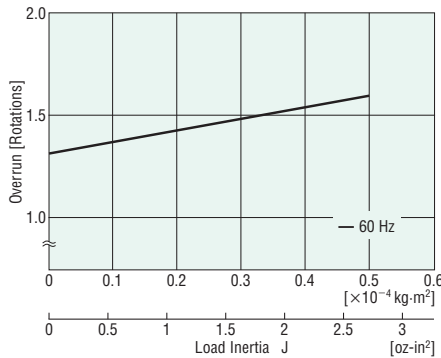

Other Motor Braking Options

In addition to the brake pack, various other brake options are available to suit a variety of applications.

How to Select a Brake Motor

Selecting Based on Stopping Accuracy

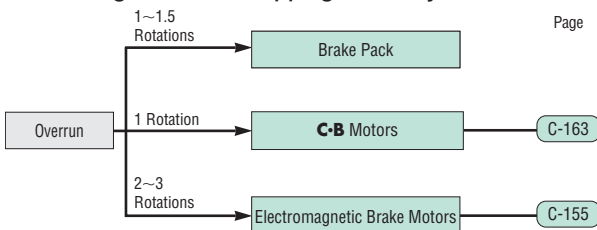

● The values for overrun applies to the motor only.

● For low-speed synchronous motors, the motor can be stopped instantly within $\pm 10^\circ$ of stopping accuracy by turning off the power supply. Refer to page C-167 for details.

Stopping Accuracy

The figure to the below shows the stopping position error (variation in stopping position) when braking force is applied to the motor using the brake pack. The diagram shows an overrun distribution when braking is repeated 500 times under the same conditions. Varying stopping positions are caused by the power-supply phase when the switch is operated to apply the brake, which could generate a maximum delay of one cycle (power supply frequency) and variation in initial braking force. The sagging at the center reflects the slot-position relationship between the stator and rotor. Refer to the braking characteristics curve representing the average overrun.

Brake Pack: **SB50W**

Motor: Induction Motor 25 W (1/30 HP)

$J: 0.25 \times 10^{-4} \text{ kg}\cdot\text{m}^2$ (1.37 oz-in²)

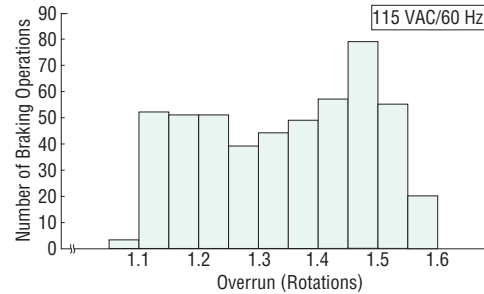

Fuse Capacity

When a brake pack is used to stop the motor instantaneously, a large amount of braking current will flow into the motor for approximately 0.4 seconds. Therefore, when connecting a fuse to the power line, select one with an appropriate capacity by referring to the braking current for the motor being used.

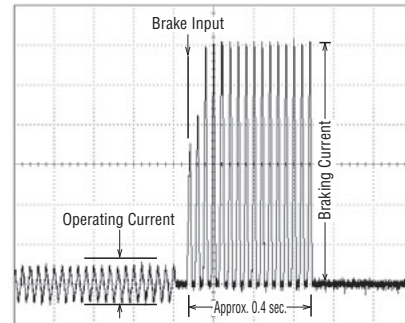

Selecting Based on Frequency of Use

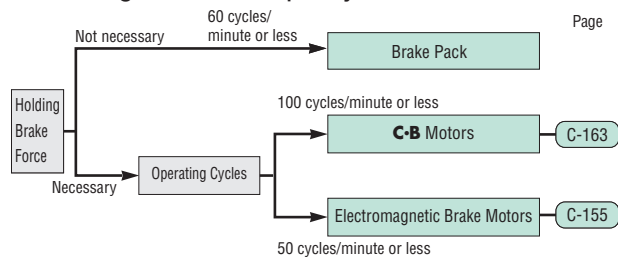

Note

- The operating cycles are based merely on brake response. The value specified above is the maximum, so it may not be possible to repeat braking operation at this frequency.
- In an actual application, be certain the surface temperature of the motor case remains at 90°C (194°F) or less.
- For low-speed synchronous motors, if operated within the permissible load inertia, the motor can start, stop and reverse within 1.5 cycles of power supply frequency. Refer to page C-167 for details.

Overview, Product Series

Constant Speed Motors

Three-Phase Induction Motors

Single-Phase Induction Motors

Reversible Motors

Electromagnetic Brake Motors

Clutch & Brake Motors

Low-Speed Synchronous Motors

Torque Motors

Watertight, Dust-Resistant Motors

Right-Angle Gearheads

Linear Heads

Brake Pack

Accessories

Installation

System Configuration

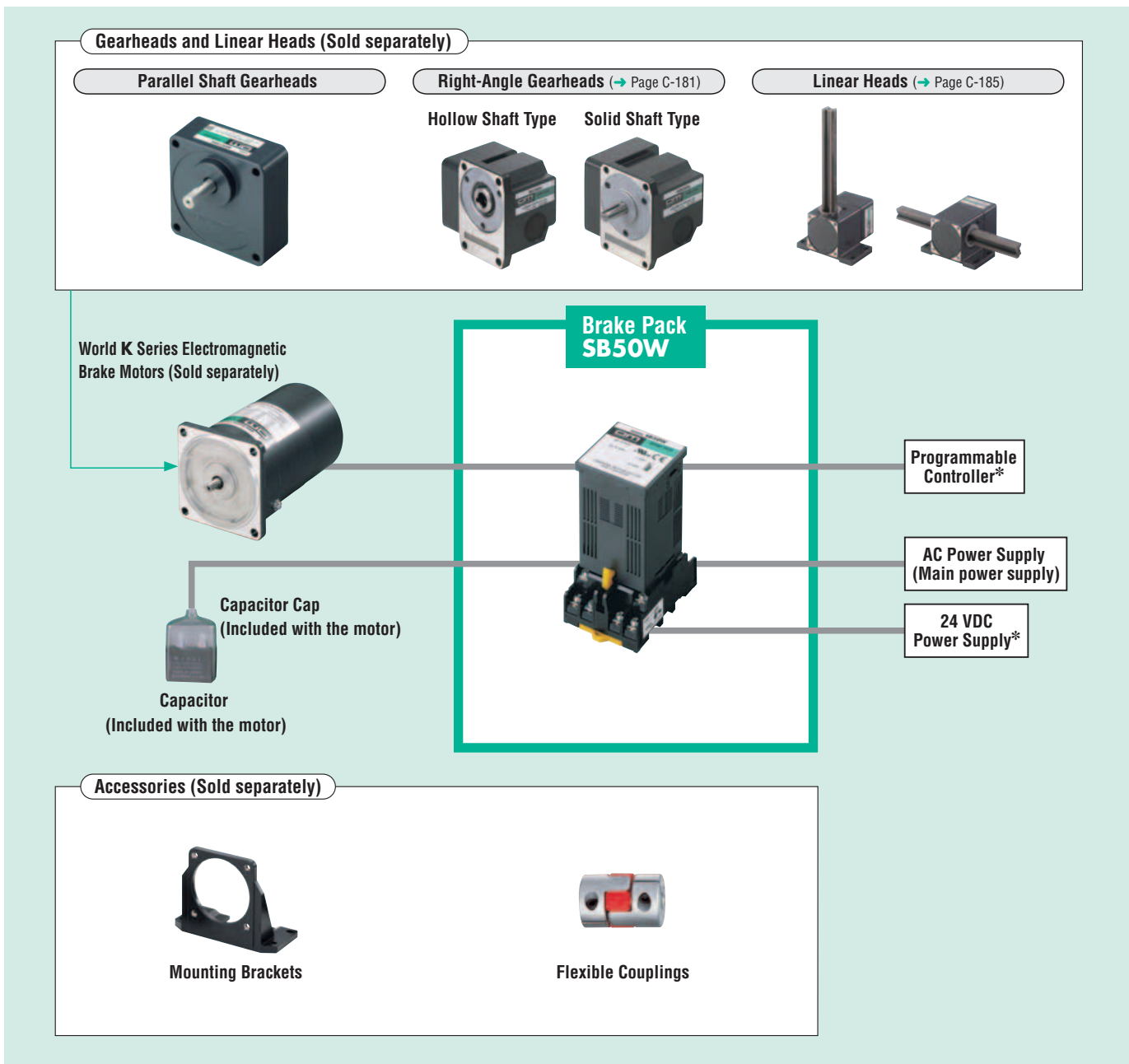

* Not supplied

Product Line

Power Supply Voltage	Product Name	List Price
Single-Phase 100-230 VAC ±10%	SB50W	\$121.00

The following items are included with each product.
 Brake Pack, Flush Mounting Socket, Operating Manual

For details (specifications, characteristics, dimensions and others) on these products please refer to either to our website, contact technical support or your nearest Oriental Motor sales office.
www.orientalmotor.com/catalog