

## EZHP Series

# EZHP6

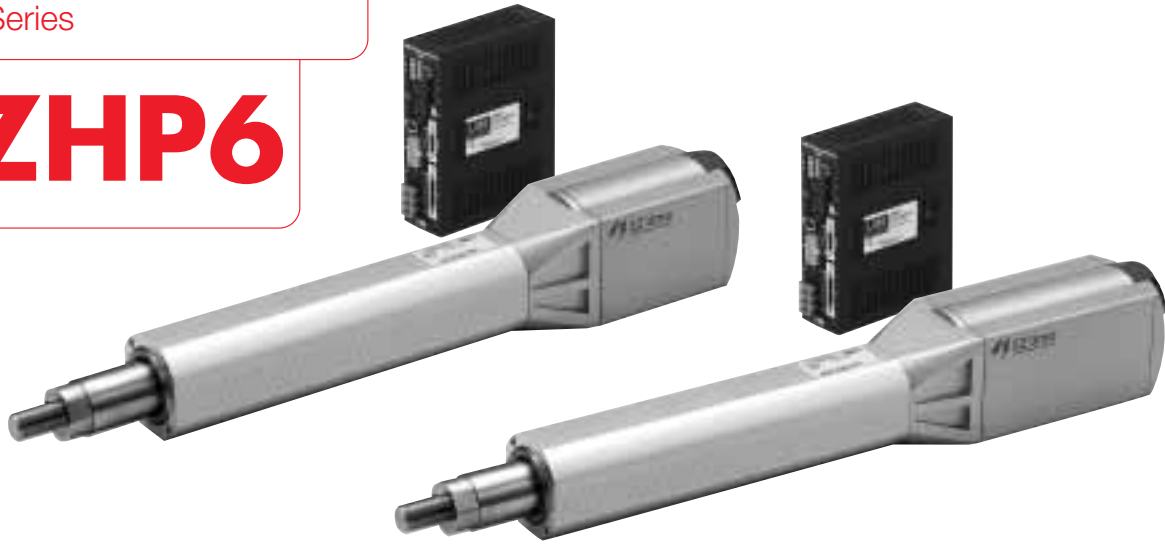

### Specifications

Model	Incremental Type		EZHP6A-□I, EZHP6C-□I				EZHP6A-□MI, EZHP6C-□MI			
	Absolute Type		EZHP6A-□A, EZHP6C-□A				EZHP6A-□MA, EZHP6C-□MA			
Motor Type	Stepping Motor with Built-in Rotor-Position Sensor									
Drive Method	Ball Screw									
Electromagnetic Brake	Not equipped									
Speed Range	mm/s		~200		~300		~200		~300	
Max. Transportable Mass	kg	Horizontal Direction*	—		—		—		—	
		Vertical Direction	—		—		30		12	
Max. Acceleration	m/s <sup>2</sup>	Horizontal Direction	—		—		—		—	
		Vertical Direction	—		—		2.5		—	
Max. Thrust Force	N	kgf	400	40	147	14.7	400	40	147	14.7
Push Force	N	kgf	400 40 (Speed: 6 mm/s or less)							
Max. Holding Brake Force	N	kgf	Power ON	400	40	—				
			Power OFF	—		—				
			Electromagnetic Brake	—		400 40				
Repetitive Positioning Accuracy	mm		±0.02							
Resolution	mm		0.01							
Lead	mm		6							
Stroke	mm		50, 100, 200, 300							
Cylinder Mass	kg		Stroke	50 : 3.3 (3.7)	100 : 3.7 (4.1)	200 : 4.6 (5.0)	300 : 5.6 (6.0)	Figure in the parentheses shows the mass of the model with electromagnetic brake.		
Ambient Temperature	°C		0~+40 (Nonfreezing)							

\*In a horizontal direction, the value cannot be shown because it varies by frictional resistance of the sliding surface.

●See page 54 for the specification and dimensions of the controller.

### General Specifications

Item	Specification
Insulation Resistance	100 MΩ minimum when measured by a DC 500 V megger between the following places. <ul style="list-style-type: none"> <li>• Windings — Case</li> <li>• Case — Windings of electromagnetic brake (Only for electromagnetic brake equipped model)</li> </ul>
Dielectric Strength	Sufficient to withstand the following for one minute. <ul style="list-style-type: none"> <li>• Windings — Case AC 1.5 kV 50 Hz</li> <li>• Case — Windings of electromagnetic brake AC 1.0 kV 50 Hz (Only for electromagnetic brake equipped model)</li> </ul>

### Cylinder/Controller Combinations

Type	Electromagnetic Brake	Model	Cylinder Model	Controller Model
Incremental Type	Not equipped	EZHP6A-□I	EZHP6A-□	EZMC24I-A
		EZHP6C-□I	EZHP6C-□	EZMC12I-C
	Equipped	EZHP6A-□MI	EZHP6A-□M	EZMC24I-A
		EZHP6C-□MI	EZHP6C-□M	EZMC12I-C

\*The box (□) in the model name and cylinder model name represents the code for stroke length.

### Push Force

Push force can be set through "Push current setting" in the program mode.

Notes:

- The above value is a reference, not guaranteed.
- When the cylinder is used in a vertical direction, an external force calculated by multiplying the weight of the carried object by the rate of gravitational acceleration is applied. Therefore, the cylinder push force must be set so as to accommodate this external force. Measure the push force using an actual load, and set an appropriate push current.

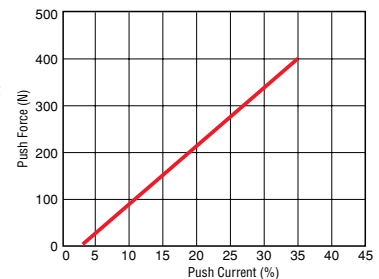

Type	Electromagnetic Brake	Model	Cylinder Model	Controller Model
Absolute Type	Not equipped	EZHP6A-□A	EZHP6A-□	EZMC24A-A
		EZHP6C-□A	EZHP6C-□	EZMC12A-C
	Equipped	EZHP6A-□MA	EZHP6A-□M	EZMC24A-A
		EZHP6C-□MA	EZHP6C-□M	EZMC12A-C

**Correlation Diagram of Speed and Thrust Force**

● Horizontal Direction/  
Vertical Direction

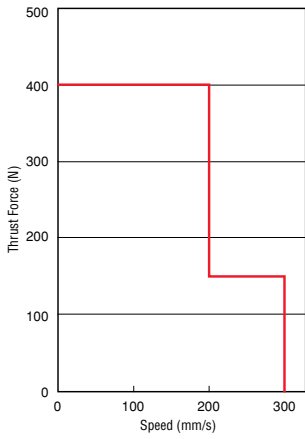

**Correlation Diagram of Speed and Load Weight**

● Vertical Direction

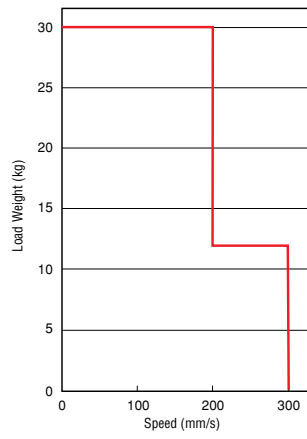

**Minimum Positioning Time**

Acceleration: 2.5 m/s<sup>2</sup> Starting Speed: 3 mm/s

● Horizontal Direction/ Vertical Direction

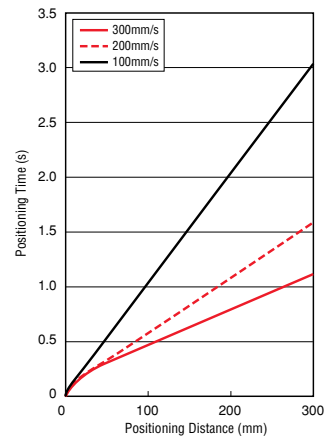

Enlargement of Positioning Distance under 100 mm

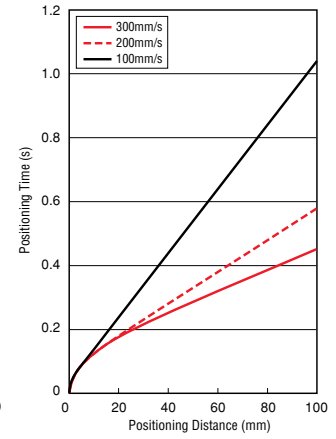

**Dimensions unit: mm**

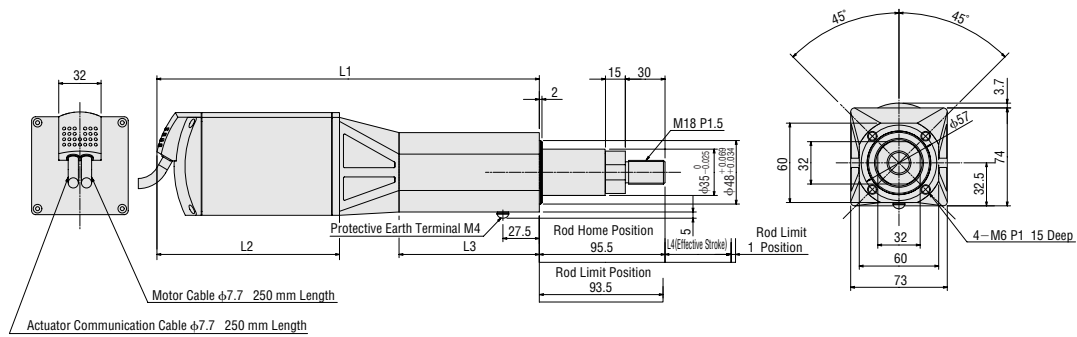

● Nut (included) 1 piece

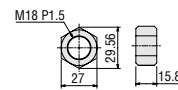

Cylinder Model	L1	L2	L3	L4
EZHP6□-05	289	138	106	50
EZHP6□-05M	324	173		
EZHP6□-10	339	138	156	100
EZHP6□-10M	374	173		
EZHP6□-20	439	138	256	200
EZHP6□-20M	474	173		
EZHP6□-30	539	138	356	300
EZHP6□-30M	574	173		

\* Enter the power supply voltage **A** or **C** in the box (□) within the cylinder model name.