

Motor Sizing Calculations

This section describes certain items that must be calculated to find the optimum motor for a particular application. Selection procedures and examples are given.

■ Selection Procedure

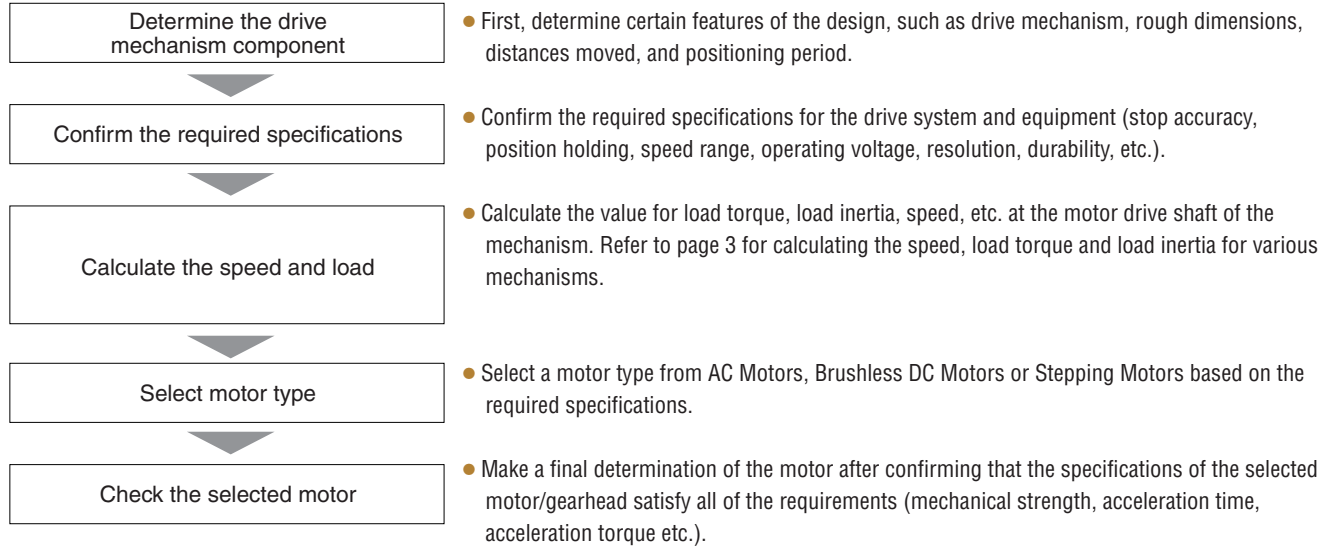

Formulas for Calculating Load Torque

Ball Screw

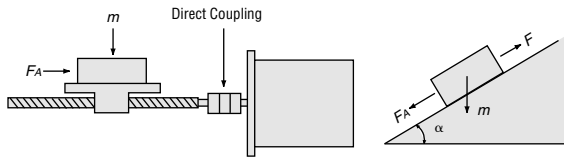

$$\tau_L = \left(\frac{FP_B}{2\pi\eta} + \frac{\mu_0 F_0 P_B}{2\pi} \right) \times \frac{1}{i} [\text{oz-in}] \dots\dots\dots ①$$

$$F = F_A + m (\sin \alpha + \mu \cos \alpha) [\text{oz.}] \dots\dots\dots ②$$

Pulley

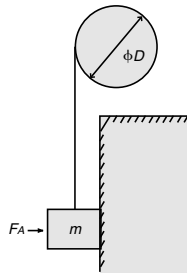

$$\tau_L = \frac{\mu F_A + m}{2\pi} \cdot \frac{\pi D}{i}$$

$$= \frac{(\mu F_A + m) D}{2i} [\text{oz-in}] \dots\dots\dots ③$$

Wire Belt Mechanism, Rack and Pinion Mechanism

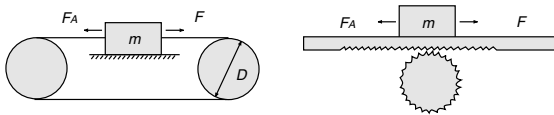

$$\tau_L = \frac{F}{2\pi\eta} \frac{\pi D}{i} = \frac{FD}{2\eta i} [\text{oz-in}] \dots\dots\dots ④$$

$$F = F_A + m (\sin \alpha + \mu \cos \alpha) [\text{oz.}] \dots\dots\dots ⑤$$

By Actual Measurement

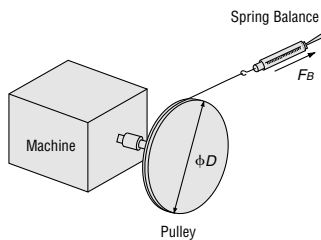

$$\tau_L = \frac{F_B D}{2} [\text{oz-in}] \dots\dots\dots ⑥$$

- F = Force of moving direction [oz.]
- F0 = Pilot pressure weight [oz.] (= 1/3 F)
- mu0 = Internal friction coefficient of pilot pressure nut (0.1 to 0.3)
- eta = Efficiency (0.85 to 0.95)
- i = Gear ratio
- PB = Ball screw pitch [inch/rev]
- FA = External force [oz.]
- FB = Force when main shaft begins to rotate [oz.]
- m = Total weight of work and table [oz.]
- mu = Frictional coefficient of sliding surfaces (0.05)
- alpha = Angle of inclination [°]
- D = Final pulley diameter [inch]

Formulas for Calculating Moment of Inertia

Inertia of a Cylinder

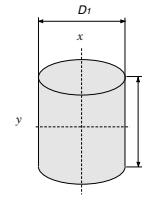

$$J_x = \frac{1}{8} m D_1^2 = \frac{\pi}{32} \rho L D_1^4 [\text{oz-in}^2] \dots\dots\dots ⑦$$

$$J_y = \frac{1}{4} m \left(\frac{D_1^2}{4} + \frac{L^2}{3} \right) [\text{oz-in}^2] \dots\dots\dots ⑧$$

Inertia of a Hollow Cylinder

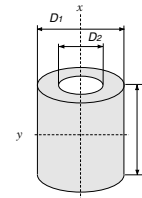

$$J_x = \frac{1}{8} m (D_1^2 + D_2^2) = \frac{\pi}{32} \rho L (D_1^4 - D_2^4) [\text{oz-in}^2] \dots\dots\dots ⑨$$

$$J_y = \frac{1}{4} m \left(\frac{D_1^2 + D_2^2}{4} + \frac{L^2}{3} \right) [\text{oz-in}^2] \dots\dots\dots ⑩$$

Inertia for Off-center Axis of Rotation

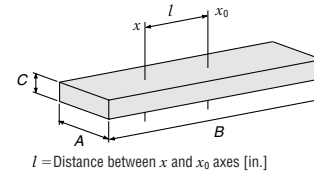

$$J_x = J_{x_0} + m l^2 = \frac{1}{12} m (A^2 + B^2 + 12 l^2) [\text{oz-in}^2] \dots\dots\dots ⑪$$

Inertia of a Rectangular Pillar

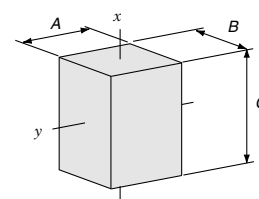

$$J_x = \frac{1}{12} m (A^2 + B^2) = \frac{1}{12} \rho A B C (A^2 + B^2) [\text{oz-in}^2] \dots\dots\dots ⑫$$

$$J_y = \frac{1}{12} m (B^2 + C^2) = \frac{1}{12} \rho A B C (B^2 + C^2) [\text{oz-in}^2] \dots\dots\dots ⑬$$

Inertia of an Object in Linear Motion

$$J = m \left(\frac{v}{\omega} \right)^2 = m \left(\frac{A}{2\pi} \right)^2 [\text{oz-in}^2] \dots\dots\dots ⑭$$

A = Unit of movement [inch/rev]

- Jx = Inertia on x axis [oz-in²]
- Jy = Inertia on y axis [oz-in²]
- Jx0 = Inertia on x0 axis [oz-in²]
- m = Weight [oz.]
- D1 = External diameter [inch]
- D2 = Internal diameter [inch]
- rho = Density [oz/in³]
- L = Length [inch]

Density	
Iron	rho = 4.64 [oz/in ³]
Aluminum	rho = 1.65 [oz/in ³]
Bronze	rho = 5 [oz/in ³]
Nylon	rho = 0.65 [oz/in ³]

Stepping Motors

This section describes in detail the key concerns in the selection procedure, such as the determination of the motion profile, the calculation of the required torque and the confirmation of the selected motor.

Operating Patterns

There are 2 basic motion profiles.

One is a start/stop operation and the other is an acceleration/deceleration operation.

Acceleration/deceleration operation is the most common.

When load inertia is small, start/stop operation can be used.

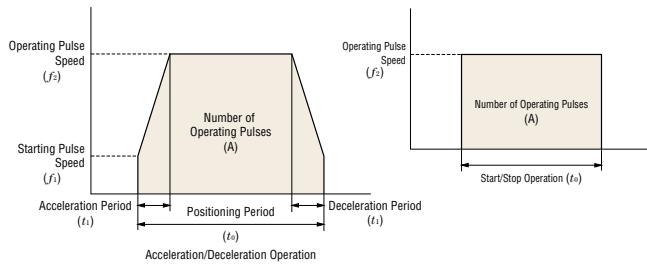

Find the Number of Operating Pulses A [pulses]

The number of operating pulses is expressed as the number of pulse signals that adds up to the angle that the motor must move to get the work from point A to point B.

$$\begin{aligned} \text{Operating Pulse (A)} &= \frac{\text{Distance per Movement}}{\text{Distance per Motor Rotation}} \times \frac{\text{No. of Pulses}}{\text{Required for 1 Motor Rotation}} \\ &= \frac{l}{l_{\text{rev}}} \times \frac{360^\circ}{\theta_s} \quad \theta_s: \text{Step Angle} \end{aligned}$$

Determine the Operating Pulse Speed f_2 [Hz]

The operating pulse speed can be found from the number of operating pulses, the positioning period and the acceleration/deceleration period.

① For Acceleration/Deceleration Operation

Acceleration/deceleration is a method of operation in which the operating pulses of a motor being used in a medium- or high-speed region are gradually changed. It is found by the equation below. Usually, the acceleration (deceleration) period (t_1) is set at roughly 25% of the positioning periods. For gentle speed changes, the acceleration torque can be kept lower than in start-stop operations.

When a motor is operated under an operating pattern like this, the acceleration/deceleration period needs to be calculated using the positioning period.

Acceleration/Deceleration

$$\text{Period [s]} = \text{Positioning Period [s]} \times 0.25$$

$$\begin{aligned} \text{Operating Pulse Speed } f_2 \text{ [Hz]} &= \frac{\text{Number of Operating Pulses [Pulses]} - \text{Starting Pulse Speed [Hz]} \times \text{Acceleration (Deceleration) Period [s]}}{\text{Positioning Period [s]} - \text{Acceleration (Deceleration) Period [s]}} \\ &= \frac{A - f_1 \cdot t_1}{t_0 - t_1} \end{aligned}$$

② For Start-Stop Operation

Start-stop is a method of operation in which the operating pulse speed of a motor being used in a low-speed region is suddenly increased without an acceleration period. It is found by the following equation. Since rapid changes in speed are required, the acceleration torque is very large.

$$\begin{aligned} \text{Operating Pulse Speed } (f_2) \text{ [Hz]} &= \frac{\text{Number of Operating Pulses [Pulses]}}{\text{Positioning Period [s]}} \\ &= \frac{A}{t_0} \end{aligned}$$

Calculate the Acceleration/Deceleration Rate T_R

Calculate the acceleration/deceleration rate from the following equation.

$$\begin{aligned} \text{Acceleration/deceleration rate } T_R \text{ [ms/kHz]} &= \frac{\text{Acceleration (Deceleration) Period [ms]}}{\text{Operating Pulse Speed [kHz]} - \text{Starting Pulse Speed [kHz]}} \\ &= \frac{t_1}{f_2 - f_1} \end{aligned}$$

* Calculate the pulse speed in full-step equivalents.

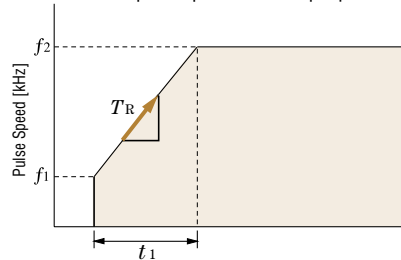

Calculate the Operating Speed from Operating Pulse speed

$$\text{Operating Speed [r/min]} = \text{Operating Pulse Speed [Hz]} \times \frac{\text{Step Angle}}{360^\circ} \times 60$$

Calculate the Load Torque T_L

(See basic equations on pages F-3)

Calculate the Acceleration Torque T_a

① For Acceleration/Deceleration Operation

$$\begin{aligned} \text{Acceleration Torque } (T_a) \text{ [oz-in]} &= \left(\frac{\text{Inertia of Rotor}}{[\text{oz-in}^2]} + \frac{\text{Total Inertia}}{[\text{oz-in}^2]} \right) \times \frac{\pi \times \text{Step Angle } [^\circ]}{180^\circ} \times \frac{\text{Operating Pulse Speed [Hz]} - \text{Starting Pulse Speed [Hz]}}{\text{Acceleration (Deceleration) Period [s]}} \\ &\quad \times \frac{1}{12 \times \text{Gravitational Acceleration [ft/s}^2\text{]}} \\ &= (J_0 + J_L) \times \frac{\pi \cdot \theta_s}{180} \times \frac{f_2 - f_1}{t_1} \times \frac{1}{g} \end{aligned}$$

② For Start-Stop Operation

$$\begin{aligned} \text{Acceleration Torque } (T_a) \text{ [oz-in]} &= \left(\frac{\text{Inertia of Rotor}}{[\text{oz-in}^2]} + \frac{\text{Total Inertia}}{[\text{oz-in}^2]} \right) \\ &\quad \times \frac{\pi \times \text{Step Angle } [^\circ] \times (\text{Operating Pulse Speed})^2 \text{ [Hz]}^2}{180^\circ \times \text{Coefficient}} \times \frac{1}{12 \times \text{Gravitational Acceleration [ft/s}^2\text{]}} \\ &= (J_0 + J_L) \times \frac{\pi \cdot \theta_s \cdot f_2^2}{180^\circ \cdot n} \times \frac{1}{g} \quad n: 3.6^\circ/\theta_s \end{aligned}$$

Calculate the Required Torque T_M

$$\begin{aligned} \text{Required Torque} &= (\text{Load Torque} + \text{Acceleration Torque}) \times \text{Safety Factor} \\ T_M \text{ [oz-in]} &= (T_L + T_a) \times S_f \end{aligned}$$

■ Choosing Between Standard AC Motors and Stepping Motors

● Selection Considerations

There are differences in characteristics between standard AC motors and stepping motors. Shown below are some of the points you should know when sizing a motor.

◆ Standard AC Motors

- ① The speed of Induction Motors and Reversible Motors vary with the size of the load torque. So, the selection should be made between the rated speed and the synchronous speed.
- ② There can be a difference of continuous and short-term ratings, due to the difference in motor specifications, despite the fact that two motors have the same output power. Motor selection should be based on the operating time (operating pattern).
- ③ Each gearhead has maximum permissible load inertia. When using a dynamic brake, changing direction quickly, or quick starts and stops, the total load inertia must be less than the maximum permissible load inertia.

◆ Stepping Motors

① Checking the Running Duty Cycle

A stepping motor is not intended to be run continuously with rated current. Lower than 50% running duty cycle is recommended.

$$\text{Running Duty Cycle} = \frac{\text{Running Time}}{\text{Running Time} + \text{Stopping Time}} \times 100$$

② Checking the Inertia Ratio

Large inertia ratios cause large overshooting and undershooting during starting and stopping, which can affect start-up times and settling times. Depending on the conditions of usage, operation may be impossible. Calculate the inertia ratio with the following equation and check that the values found are at or below the inertia ratios shown in the table.

$$\begin{aligned} \text{Inertia Ratio} &= \frac{\text{Total Inertia of the Machine [oz-in}^2\text{]}}{\text{Rotor Inertia of the Motor [oz-in}^2\text{]}} \\ &= \frac{J_L}{J_0} \end{aligned}$$

Inertia Ratio (Reference Values)

Product Series	Inertia Ratio
αSTEP	30
RK Series	10 Maximum

When these values are exceeded, we recommend a geared motor.

Using a geared motor can increase the drivable inertia load.

* Except geared motor types

$$\begin{aligned} \text{Inertia Ratio} &= \frac{\text{Total Inertia of the Machine [oz-in}^2\text{]}}{\text{Rotor Inertia of the Motor [oz-in}^2\text{]} \times (\text{Gear Ratio})^2} \\ &= \frac{J_L}{J_0 \cdot i^2} \end{aligned}$$

③ Check the Acceleration/Deceleration Rate

Most controllers, when set for acceleration or deceleration, adjust the pulse speed in steps. For that reason, operation may sometimes not be possible, even though it can be calculated.

Calculate the acceleration/deceleration rate from the following equation and check that the value is at or above the acceleration/deceleration rate in the table.

$$\begin{aligned} \text{Acceleration/Deceleration Rate } T_R [\text{ms/kHz}] &= \frac{\text{Acceleration (Deceleration) Period [ms]}}{\text{Operating Pulse Speed [Hz]} - \text{Starting Pulse Speed [Hz]}} \\ &= \frac{t_1}{f_2 - f_1} \end{aligned}$$

* Calculate the pulse speed in full-step equivalents.

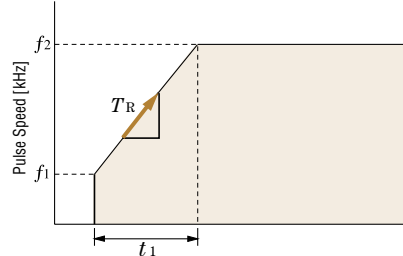

Acceleration Rate (Reference Values with EMP Series)

Model	Motor Frame Size inch (mm)	Acceleration/Deceleration Rate T_R [ms/kHz]
αSTEP	1.10(28), 1.65(42), 2.36(60), 3.35(85)	0.5 Min.
RK Series	1.65(42), 2.36(60), 3.35(85), 3.54(90)	20 Min. 30 Min.

If below the minimum value, change the operating pattern's acceleration (deceleration) period.

④ Checking the Required Torque

Check that the required torque falls within the pull-out torque of the speed-torque characteristics.

Safety Factor: Sf (Reference Value)

Product Series	Safety Factor
αSTEP	1.5~2
RK Series	2

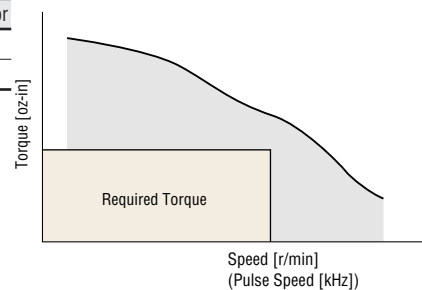

■ Sizing Example

● Ball Screw

Using Stepping Motors (α_{STEP})

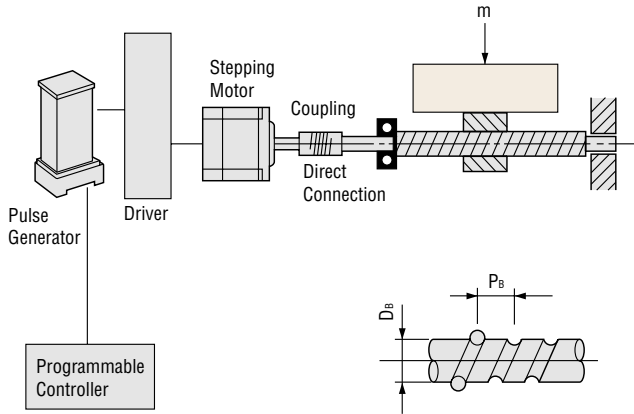

◆ Determine the Drive Mechanism

Total mass of the table and work:	$m = 90 \text{ lb. (40 kg)}$
Frictional coefficient of sliding surfaces:	$\mu = 0.05$
Ball screw efficiency:	$\eta = 0.9$
Internal frictional coefficient of pilot pressure nut:	$\mu_0 = 0.3$
Ball screw shaft diameter:	$D_B = 0.6 \text{ inch (1.5 cm)}$
Total length of ball screw:	$L_B = 23.6 \text{ inch (60 cm)}$
Material of ball screw:	Iron [density $\rho = 4.64 \text{ oz/in}^3$ ($7.9 \times 10^{-3} \text{ kg/cm}^3$)]
Pitch of ball screw:	$P_B = 0.6 \text{ inch (1.5 cm)}$
Desired Resolution (feed per pulse):	$\Delta l = 0.001 \text{ inch (0.03 mm)/step}$
Feed:	$l = 7.01 \text{ inch (180 mm)}$
Positioning period:	$t_0 = 0.8 \text{ sec.}$

◆ Calculate the Required Resolution

$$\begin{aligned} \text{Required Resolution } \theta_s &= \frac{360^\circ \times \text{Desired Resolution } (\Delta l)}{\text{Ball Screw Pitch } (P_B)} \\ &= \frac{360^\circ \times 0.001}{15} = 0.72^\circ \end{aligned}$$

α_{STEP} can be connected directly to the application.

◆ Determine the Operating Pattern

(see page F-4, see basic equations on pages F-3)

(1) Finding the Number of Operating Pulses (A) [pulses]

$$\begin{aligned} \text{Operating pulses (A)} &= \frac{\text{Feed per Unit } (l)}{\text{Ball Screw Pitch } (P_B)} \times \frac{360^\circ}{\text{Step Angle } (\theta_s)} \\ &= \frac{7.01}{0.6} \times \frac{360^\circ}{0.72^\circ} = 6000 \text{ pulses} \end{aligned}$$

(2) Determine the Acceleration (Deceleration) Period t_1 [sec]

An acceleration (deceleration) period of 25% of the positioning period is appropriate.

$$\text{Acceleration (deceleration) period } (t_1) = 0.8 \times 0.25 = 0.2 \text{ sec}$$

(3) Determine the Operating Pulse Speed f_2 [Hz]

$$\begin{aligned} \text{Operating pulse speed } f_2 &= \frac{\text{Number of Operating Pulses [A]} - \text{Starting Pulses} \times \text{Acceleration Period [t]} + \text{Acceleration (Deceleration) Period [t]}}{\text{Positioning Period [t]}} \\ &= \frac{6000 - 0}{0.8 - 0.2} = 10000 \text{ Hz} \end{aligned}$$

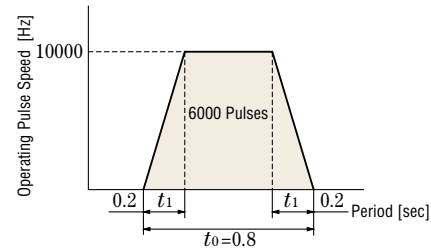

(4) Calculate the Operating Speed N [r/min]

$$\begin{aligned} \text{Operating Speed} &= f_2 \times \frac{\theta_s}{360} \times 60 \\ &= 10000 \times \frac{0.72}{360} \times 60 = 1200 \text{ [r/min]} \end{aligned}$$

◆ Calculate the Required Torque T_M [oz-in]

(see page F-4)

(1) Calculate the Load Torque T_L [oz-in]

$$\begin{aligned} \text{Load in Shaft Direction } F &= F_A + m (\sin \alpha + \mu \cos \alpha) \\ &= 0 + 90 (\sin 0 + 0.05 \cos 0) \\ &= 4.5 \text{ lb.} \end{aligned}$$

$$\text{Pilot Pressure Load } F_0 = \frac{F}{3} = \frac{4.5}{3} = 1.5 \text{ lb.}$$

$$\begin{aligned} \text{Load Torque } T_L &= \frac{F \cdot P_B}{2\pi\eta} + \frac{\mu_0 \cdot F_0 \cdot P_B}{2\pi} \\ &= \frac{4.5 \times 0.6}{2\pi \times 0.9} + \frac{0.3 \times 1.5 \times 0.6}{2\pi} \\ &= 0.52 \text{ lb-in} = 8.3 \text{ oz-in} \end{aligned}$$

(2) Calculate the Acceleration Torque T_a [oz-in]

① Calculate the total moment of inertia J_L [oz-in²]
(See page F-3 for basic equations)

$$\begin{aligned} \text{Inertia of Ball Screw } J_B &= \frac{\pi}{32} \cdot \rho \cdot L_B \cdot D_B^4 \\ &= \frac{\pi}{32} \times 4.64 \times 23.6 \times 0.6^4 \\ &= 1.39 \text{ oz-in}^2 \end{aligned}$$

$$\begin{aligned} \text{Inertia of Table and Work } J_T &= m \left(\frac{P_B}{2\pi} \right)^2 = 90 \times \left(\frac{0.6}{2\pi} \right)^2 \\ &= 0.82 \text{ lb-in}^2 = 13.1 \text{ oz-in}^2 \end{aligned}$$

$$\text{Total Inertia } J_L = J_B + J_T = 1.39 + 13.1 = 14.5 \text{ oz-in}^2$$

② Calculate the acceleration torque T_a [oz-in]

$$\begin{aligned} \text{Acceleration torque } T_a &= \frac{J_0 + J_L}{g} \times \frac{\pi \cdot \theta_s}{180^\circ} \times \frac{f_2 - f_1}{t_1} \\ &= \frac{J_0 + 14.5}{386} \times \frac{\pi \times 0.72}{180} \times \frac{10000 - 0}{0.2} \\ &= 1.63 J_0 + 23.6 \text{ oz-in} \end{aligned}$$

(3) Calculate the Required Torque T_M [oz-in]

$$\begin{aligned} \text{Required torque } T_M \text{ [oz-in]} &= (T_L + T_a) \times 2 \\ &= \{8.3 + (1.63 J_0 + 23.6)\} \times 2 \\ &= 3.26 J_0 + 63.8 \text{ oz-in} \end{aligned}$$

◆ Select a Motor

(1) Provisional Motor Selection

Model	Rotor Inertia [oz-in ²]	Required Torque	
		oz-in	N·m
AS66AA	2.2	71	0.5

(2) Determine the Motor from the Speed-Torque Characteristics

AS66AA

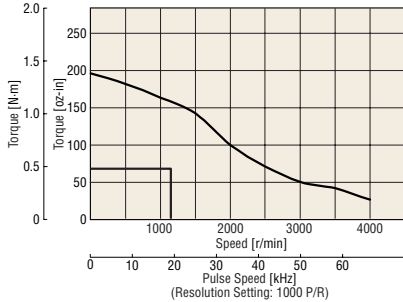

Select a motor for which the required torque falls within the pull-out torque of the speed-torque characteristics.

● Ball Screw

Using Standard AC Motors

This example demonstrates how to select an AC motor with an electromagnetic brake for use on a tabletop moving vertically on a ball screw. In this case, a motor must be selected that meets the following basic specifications.

Required and Structural Specifications

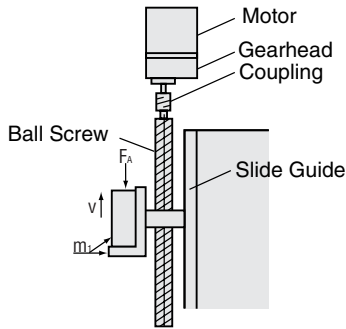

- Total weight of table and work $m = 100$ lb.
- Table speed $V = 0.6$ in./s $\pm 10\%$
- Ball screw pitch $P_B = 0.197$ in.
- Ball screw efficiency $\eta = 0.9$
- Ball screw friction coefficient $\mu_0 = 0.3$
- Friction coefficient of sliding surface (Slide guide) $\mu = 0.05$
- Motor power supply Single-Phase 115 VAC 60 Hz
- Ball screw total length $L_B = 31.5$ in.
- Ball screw shaft diameter $D_B = 0.787$ in.
- Ball screw material Iron (density $\rho = 4.64$ oz/in.³)
- Distance moved for one rotation of ball screw $A = 0.197$ in.
- External force $F_A = 0$ lb.
- Ball screw tilt angle $\alpha = 90^\circ$
- Movement time 5 hours/day
- Brake must provide holding torque

◆ Determine the Gear Ratio

Speed at the gearhead output shaft: N_G

$$N_G = \frac{V \cdot 60}{P_B} = \frac{(0.6 \pm 0.06) \times 60}{0.197} = 182 \pm 18 \text{ r/min}$$

Because the rated speed for a 4-pole motor at 60 Hz is 1450~1550 r/min, the gear ratio (i) is calculated as follows:

$$i = \frac{1450 \sim 1550}{N_G} = \frac{1450 \sim 1550}{182 \pm 18} = 7.2 \sim 9.5$$

From within this range a gear ratio of $i = 9$ is selected.

◆ Calculate the Required Torque

F , the load weight in the direction of the ball screw shaft, is obtained as follows:

$$F = F_A + m (\sin \alpha + \mu \times \cos \alpha) = 0 + 100 (\sin 90 + 0.05 \times \cos 90) = 100 \text{ lb.}$$

Preload weight F_0 :

$$F_0 = \frac{F}{3} = 33.3 \text{ lb.}$$

Load torque T_L :

$$T_L = \frac{F \times P_B}{2\pi\eta} + \frac{\mu_0 \times F_0 \times P_B}{2\pi} = \frac{100 \times 0.197}{2\pi \times 0.9} + \frac{0.3 \times 33.3 \times 0.197}{2\pi} = 3.8 \text{ lb-in}$$

This value is the load torque at the gearhead drive shaft, and must be converted into load torque at the motor output shaft.

The required torque at the motor output shaft (T_M) is given by:

$$T_M = \frac{T_L}{i \cdot \eta_G} = \frac{3.8}{9 \times 0.81} = 0.52 \text{ [lb-in]} = 8.32 \text{ oz-in}$$

(Gearhead transmission efficiency $\eta_G = 0.81$)

Look for a margin of safety of 2 times.

$$8.32 \times 2 = 16.64 \text{ oz-in}$$

To find a motor with a start-up torque of 16.64 oz-in or more, select motor **5RK40GN-AWMU**. This motor is equipped with an electromagnetic brake to hold a load. A gearhead with a gear ratio of 9:1 that can be connected to the motor

5RK40GN-AWMU is **5GN9KA**.

The rated motor torque is greater than the required torque, so the speed under no-load conditions (1740 r/min) is used to confirm that the motor produces the required speed.

◆ Load Inertia Check

$$\text{Ball Screw Moment of Inertia } J_1 = \frac{\pi \times \rho \times L_B \times D_B^4}{32} = \frac{\pi \times 4.64 \times 31.5 \times (0.787)^4}{32} = 5.5 \text{ oz-in}^2$$

$$\text{Table and Work Moment of Inertia } J_2 = m \left(\frac{A}{2\pi} \right)^2 = 100 \times 16 \left(\frac{0.197}{2\pi} \right)^2 = 1.57 \text{ oz-in}^2$$

$$\text{Gearhead shaft total load inertia } J = 5.5 + 1.57 = 7.07 \text{ [oz-in}^2\text{]}$$

Here, the **5GN9KA** permitted load inertia is (see page A-12):

$$J_G = J_M \times i^2 = 4 \times 9^2 = 324 \text{ oz-in}^2$$

Therefore, $J < J_G$, the load inertia is less than the permitted inertia, so there is no problem. There is margin for the torque, so the rotation rate is checked with the no-load rotation rate (about 1750 r/min).

$$V = \frac{N_M \cdot P}{60 \cdot i} = 0.64 \text{ in./s} \quad (\text{where } N_M \text{ is the motor speed})$$

This confirms that the motor meets the specifications.

● **Belt and Pully**

Using Standard AC Motors

Here is an example of how to select an induction motor to drive a belt conveyor.

In this case, a motor must be selected that meets the following basic specifications.

Required Specifications and Structural Specifications

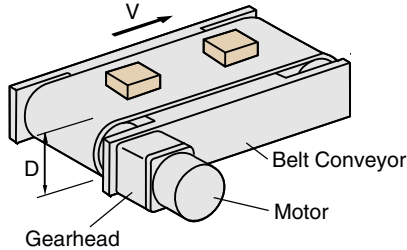

- Total weight of belt and work $m_1 = 30$ lb.
- Friction coefficient of sliding surface $\mu = 0.3$
- Drum radius $D = 4$ inch
- Weight of drum $m_2 = 35.27$ oz.
- Belt roller efficiency $\eta = 0.9$
- Belt speed $V = 7$ inch/s $\pm 10\%$
- Motor power supply Single-Phase 115 VAC 60 Hz

◆ **Determine the Gear Ratio**

Speed at the gearhead output shaft:

$$N_G = \frac{V \cdot 60}{\pi \cdot D} = \frac{(7 \pm 0.7) \times 60}{\pi \times 4} = 33.4 \pm 3.3 \text{ r/min}$$

Because the rated speed for a 4-pole motor at 60 Hz is 1450~1550 r/min, the gear ratio (i) is calculated as follows:

$$i = \frac{1450 \sim 1550}{N_G} = \frac{1450 \sim 1550}{33.4 \pm 3.3} = 39.5 \sim 51.5$$

From within this range a gear ratio of $i = 50$ is selected.

◆ **Calculate the Required Torque**

On a belt conveyor, the greatest torque is needed when starting the belt. To calculate the torque needed for start-up, the friction coefficient (F) of the sliding surface is first determined:

$$F = \mu m_1 = 0.3 \times 30 = 9 \text{ lb.} = 144 \text{ oz.}$$

Load torque (T_L) is then calculated by:

$$T_L = \frac{F \cdot D}{2 \cdot \eta} = \frac{144 \times 4}{2 \times 0.9} = 320 \text{ oz-in}$$

The load torque obtained is actually the load torque at the gearhead drive shaft, so this value must be converted into load torque at the motor output shaft. If the required torque at the motor output shaft is T_M , then:

$$T_M = \frac{T_L}{i \cdot \eta_G} = \frac{320}{50 \times 0.66} = 9.7 \text{ oz-in}$$

(Gearhead transmission efficiency $\eta_G = 0.66$)

Look for a margin of safety of 2 times, taking into consideration commercial power voltage fluctuation.

$$9.7 \times 2 = 19.4 \text{ oz-in}$$

The suitable motor is one with a starting torque of 19.4 oz-in or more. Therefore, motor **5IK40GN-AWU** is the best choice.

Since a gear ratio of 50:1 is required, select the gearhead **5GN50KA** which may be connected to the **5IK40GN-AWU** motor.

◆ **Load Inertia**

Roller Moment of Inertia

$$J_1 = \frac{1}{8} \times m_2 \times D^2 \times 2 = \frac{1}{8} \times 35.27 \times 4^2 \times 2 = 141 \text{ oz-in}^2$$

Belt and Work Moment of Inertia

$$J_2 = m_1 \left(\frac{\pi \times D}{2\pi} \right)^2 = 30 \times 16 \times \left(\frac{\pi \times 4}{2\pi} \right)^2 = 1920 \text{ oz-in}^2$$

Gearhead Shaft Load Inertia

$$J = J_1 + J_2 = 141 + 1920 = 2061 \text{ oz-in}^2$$

Here, the **5GN50KA** permitted load inertia is: $J_G = 4 \times 50^2 = 10000 \text{ oz-in}^2$

(See page A-12)

Therefore, $J < J_G$, the load inertia is less than the permitted inertia, so there is no problem.

Since the motor selected has a rated torque of 36.1 oz-in, which is somewhat larger than the actual load torque, the motor will run at a higher speed than the rated speed.

Therefore the speed is used under no-load conditions (approximately 1740 r/min) to calculate belt speed, and thus determine whether the selected product meets the required specifications.

$$V = \frac{N_M \cdot \pi \cdot D}{60 \cdot i} = \frac{1740 \times \pi \times 4}{60 \times 50} = 7.3 \text{ in/s}$$

(Where N_M is the motor speed)

The motor meets the specifications.

● Conveyor

Using Brushless DC Motors

Here is an example of how to select a speed control motor to drive a belt conveyor.

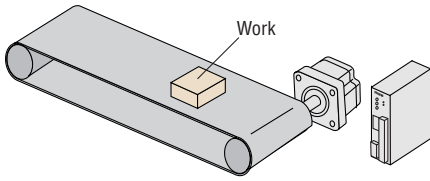

● Performance

Belt speed V_L is 0.6 in./s~40 in./s

● Specifications for belt and work

Condition: Motor power supply Single-Phase 115 VAC
Belt conveyor drive

- Roller diameter $D = 4$ inch
- Mass of roller $m_1 = 2.2$ lb.
- Total mass of belt and work $m_2 = 33$ lb.
- Friction coefficient of sliding surface $\mu = 0.3$
- Belt roller efficiency $\eta = 0.9$

◆ Find the Required Speed Range

For the gear ratio, select 15:1 (speed range: 2~200) from the permissible torque table for combination type on page B-14 so that the minimum/maximum speeds fall within the speed range.

$$N_G = \frac{60V_L}{\pi D} \quad N_G: \text{Speed at the gearhead output shaft}$$

Belt Speed

$$0.6 \text{ inch/s} \cdots \cdots \frac{60 \times 0.6}{\pi \times 4} = 2.87 \text{ r/min (Minimum Speed)}$$

$$40 \text{ inch/s} \cdots \cdots \frac{60 \times 40}{\pi \times 4} = 191 \text{ r/min (Maximum Speed)}$$

◆ Calculate the Load Inertia J_G

Load Inertia of Roller : J_{m1}

$$J_{m1} = \frac{1}{8} \times m_1 \times D^2 = \frac{1}{8} \times 2.2 \times 16 \times 4^2 = 70.4 \text{ oz-in}^2$$

Load inertia of belt and work : J_{m2}

$$J_{m2} = m_2 \times \left(\frac{\pi D}{2\pi} \right)^2 = 33 \times \left(\frac{\pi \times 4}{2\pi} \right)^2 = 132 \text{ oz-in}^2$$

The load inertia J_G is calculated as follows:

$$J_G = J_{m1} \times 2 + J_{m2} = 2 \times 70.4 + 132 = 273 \text{ oz-in}^2$$

From the specifications on page B-15, the permissible load inertia for **BX5120A-15** is 2300 oz-in² (4.2×10^{-2} kg·m²)

◆ Calculate the Load Torque T_L

Friction Coefficient of the Sliding Surface: $F = \mu \cdot m_2 = 0.3 \times 33 = 9.9$ lb.

$$\text{Load Torque } T_L = \frac{F \cdot D}{2\eta} = \frac{9.9 \times 4}{2 \times 0.9} = 22 \text{ lb-in}$$

Select **BX5120A-15** from the permissible torque table on page B-14.

Since the permissible torque is 47 lb-in (5.4 N·m), the safety margin is

$$T_M/T_L = 50/22 = 2.3$$

Usually, a motor can operate at the safety margin of 1.5~2 or more.

● Index Table

Using Stepping Motors

Geared stepping motors are suitable for systems with high inertia, such as index tables.

◆ Determine the Drive Mechanism

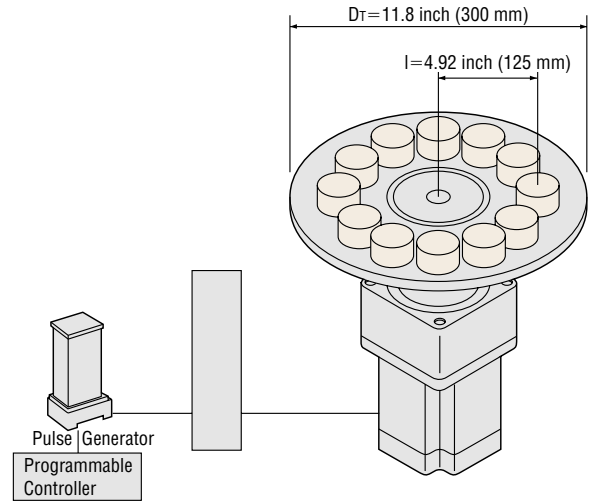

- Diameter of index table: $D_T = 11.8$ inch (300 mm)
- Index table thickness: $L_T = 0.39$ inch (10 mm)
- Thickness of work: $L_W = 1.18$ inch (30 mm)
- Diameter of work: $D_W = 1.57$ inch (40 mm)
- Material of table and load: Iron [density $\rho = 4.64$ oz/in³ (7.9×10^3 kg/m³)]
- Number of loads: 10 (one every 36°)
- Distance from center of index table to center of load: $l = 4.92$ inch (125 mm)
- Positioning angle: $\theta = 36^\circ$
- Positioning period: $t_0 = 0.25$ [sec]

The **αSTEP PN** geared (gear ratio 10:1) can be used.

Gear Ratio: $i = 10$

Resolution: $\theta_s = 0.036^\circ$

Speed Range (Gear Ratio 10:1) is 0~300 r/min

◆ Determine the Operating Pattern

(see page F-4, see basic equations on page F-3)

(1) Find the Number of Operating Pulses (A) [pulses]

$$\begin{aligned} \text{Operating pulses (A)} &= \frac{\text{Angle rotated per movement } (\theta)}{\text{Gear output shaft step angle } (\theta_s)} \\ &= \frac{36^\circ}{0.036^\circ} = 1000 \text{ Pulses} \end{aligned}$$

(2) Determine the Acceleration (Deceleration) Period t_1 [sec]

Generally, an acceleration (deceleration) period should be set approximately 25% or more of the positioning period.

In this example we will set $t_1 = 0.1$, $t_1 = 0.1$ [s] is provided as the acceleration (deceleration) period.

(3) Calculate the Operation Speed

$$\begin{aligned} \text{Operating N} &= \frac{60}{360} \times \frac{\theta}{t_0 - t_1} = \frac{60}{360} \times \frac{36}{0.25 - 0.1} \\ &= 40 \text{ [r/min]} \end{aligned}$$

(4) Determine the Operating Pulse Speed f_2 [Hz]

$$\begin{aligned} \text{Operating Pulse Speed } f_2 &= \frac{\text{Number of Operating Pulses [A]} \times \text{Starting Pulses} \times \text{Acceleration Period [} t_1 \text{]} + \text{Acceleration Period [} t_1 \text{]} \times \text{Deceleration Period [} t_1 \text{]}}{\text{Positioning Period [} t_0 \text{]} + \text{Acceleration Period [} t_1 \text{]} + \text{Deceleration Period [} t_1 \text{]}} \\ &= \frac{600 - 0}{0.25 - 0.1} = 6667 \text{ [Hz]} \end{aligned}$$

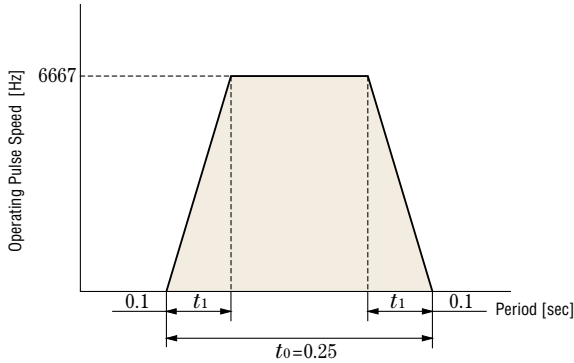

◆ Calculate the Required Torque T_M [oz-in]

(See page F-4)

(1) Calculate the Load Torque T_L [oz-in]

(See page F-3 for basic equations)

Frictional load is omitted because it is negligible. Load torque is considered 0.

(2) Calculate the Acceleration Torque T_a [oz-in]

① Calculate the Total Inertia J_L [oz-in²]

(See page F-4 for basic equations)

$$\begin{aligned} \text{Inertia of Table } J_T &= \frac{\pi}{32} \cdot \rho \cdot L_T \cdot D_T^4 \\ &= \frac{\pi}{32} \times 4.64 \times 0.39 \times 11.8^4 \\ &= 3400 \text{ oz-in}^2 \end{aligned}$$

$$\begin{aligned} \text{Inertia of Work } J_c &= \frac{\pi}{32} \cdot \rho \cdot L_w \cdot D_w^4 \\ \text{(Center of gravity)} \\ &= \frac{\pi}{32} \times 4.64 \times 1.18 \times 1.57^4 \\ &= 3.3 \text{ oz-in}^2 \end{aligned}$$

$$\begin{aligned} \text{Weight of Work } m &= \pi \left(\frac{D_w}{2}\right)^2 \cdot L_w \cdot \rho \\ &= \pi \left(\frac{1.57}{2}\right)^2 \times 1.18 \times 4.64 \\ &= 10.6 \text{ oz.} \end{aligned}$$

The inertia of the work J_w [oz-in²] relative to the center of rotation can be obtained from distance L [inch] between the center of work and center of rotation, mass of work m [oz], and inertia of work (center of gravity) J_c [oz-in²].

Since the number of work pieces n , is 10 [pcs],

$$\begin{aligned} \text{Inertia of Work } J_w &= 10 \times (J_c + m \times L^2) \\ \text{(Center of rotation)} \\ &= 10 \times (3.3 + 10.6 \times 4.92^2) \\ &= 2600 \text{ [oz-in}^2 \text{]} \end{aligned}$$

$$\begin{aligned} \text{Total Inertia } J_L &= J_T + J_w = 3400 + 2600 \\ &= 6000 \text{ oz-in}^2 \end{aligned}$$

② Calculating the Acceleration Torque T_a [oz-in]

$$\begin{aligned} \text{Acceleration Torque } T_a &= \frac{(J_o \cdot i^2 + J_L)}{g} \cdot \frac{1}{12} \cdot \frac{\pi \cdot \theta_s}{180} \cdot \frac{f_2 - f_1}{t_1} \\ &= \frac{(J_o \times 10 + 6000)}{32.2} \times \frac{1}{12} \times \frac{\pi \times 0.036}{180} \times \frac{6667 - 0}{0.1} \\ &= 4.19J_o + 650 \text{ [oz-in]} \end{aligned}$$

(3) Calculate the Required Torque T_M [oz-in]

Safety Factor $S_f = 2$

$$\begin{aligned} \text{Required Torque} &= (T_L + T_a) \times 2 \\ T_M \text{ [oz-in]} &= \{0 + (4.19J_o + 650)\} \times 2 \\ &= 8.38J_o + 1300 \text{ [oz-in]} \end{aligned}$$

◆ Select a Motor

(1) Provisional Motor Selection

Model	Rotor Inertia oz-in ²	Required Torque	
		lb-in	[N·m]
AS66AA-N10	$J_o = 2.2$	84	9.55

(2) Determine the Motor from the Speed-Torque Characteristics

AS66AA-N10

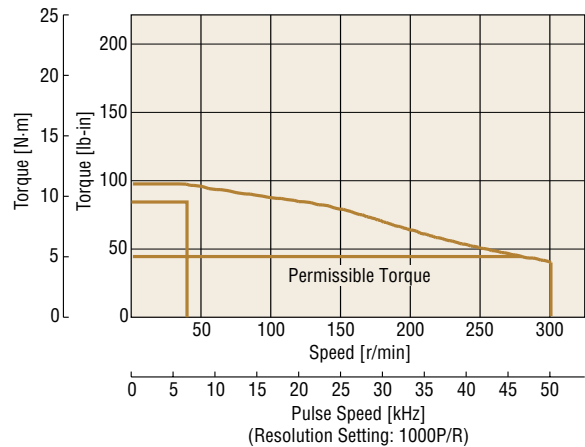

The total torque of the system is the sum of the load torque plus the acceleration torque. The total torque times the safety factor must not exceed the permissible torque.